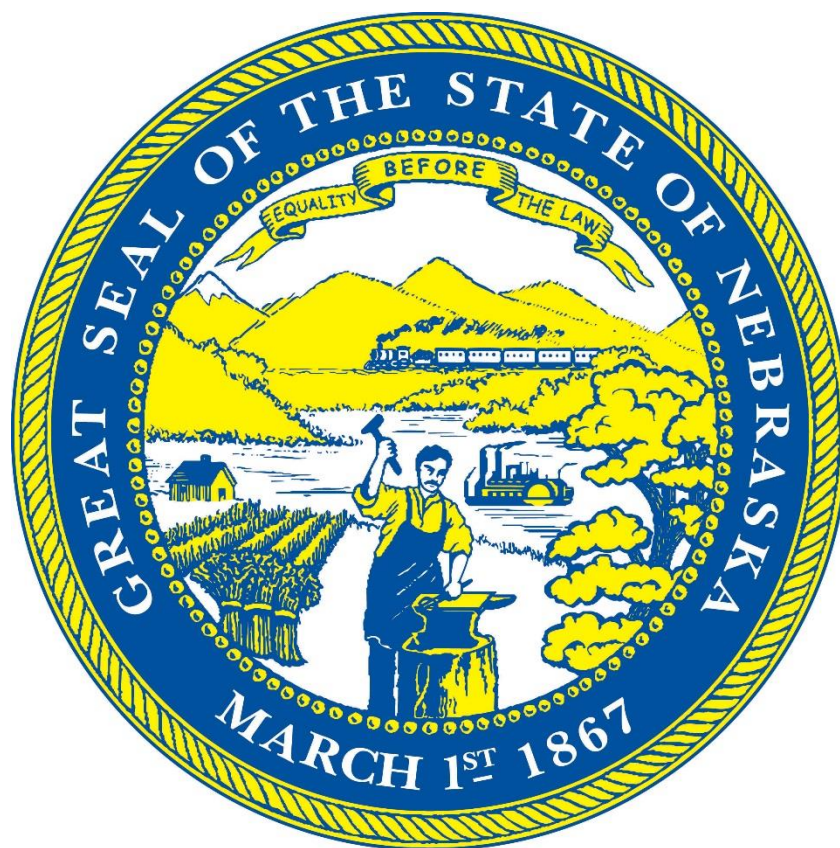
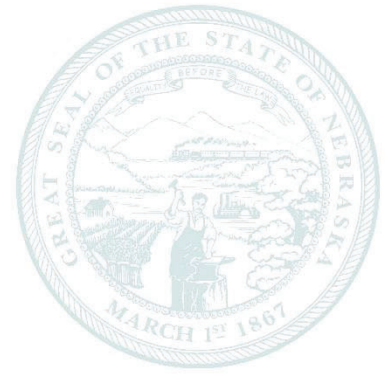


# Roadway Design Manual



Nebraska Department of  
Transportation

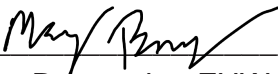




Pete Ricketts, Governor

The Nebraska Department of Transportation Roadway Design Manual, May 2022, has been approved for use.

Approved by:  / \_\_\_\_\_  
Syslo, Mick S  
May 16 2022 3:49 PM  
Mick Syslo, Roadway Design Engineer, P.E. Date

Approved by:  / 5/17/2022  
Mary Burroughs, FHWA  
Engineering and Operations Team Leader, NE FHWA Date

John R. Selmer, P.E., Director

**Department of Transportation**

**MAILING ADDRESS**

PO Box 94759  
Lincoln, NE 68509-4759

**PHYSICAL ADDRESS**

1500 Highway 2  
Lincoln, NE 68502

**PHONE** 402-471-4567

**EMAIL** [NDOT.ContactUs@nebraska.gov](mailto:NDOT.ContactUs@nebraska.gov)

[dot.nebraska.gov](http://dot.nebraska.gov)



# TABLE OF CONTENTS

INTRODUCTION .....	I
CHAPTER ONE ROADWAY DESIGN STANDARDS .....	1-1
CHAPTER TWO ROADWAY DESIGN PROCESS .....	2-1
CHAPTER THREE ROADWAY ALIGNMENT .....	3-1
CHAPTER FOUR INTERSECTIONS, DRIVEWAYS and CHANNELIZATION .....	4-1
CHAPTER FIVE INTERSTATES, GRADE SEPARATIONS, AND INTERCHANGES .....	5-1
CHAPTER SIX THE TYPICAL ROADWAY CROSS-SECTION.....	6-1
CHAPTER SEVEN EARTHWORK .....	7-1
CHAPTER EIGHT SURFACING.....	8-1
CHAPTER NINE GUARDRAIL AND ROADSIDE BARRIERS .....	9-1
CHAPTER TEN MISCELLANEOUS DESIGN ISSUES .....	10-1
CHAPTER ELEVEN HIGHWAY PLANS ASSEMBLY .....	11-1
CHAPTER TWELVE COST ESTIMATING & FUNDING .....	12-1
CHAPTER THIRTEEN PLANNING AND PROJECT DEVELOPMENT .....	13-1
CHAPTER FOURTEEN TRAFFIC.....	14-1
CHAPTER FIFTEEN RIGHT-OF-WAY .....	15-1
CHAPTER SIXTEEN PEDESTRIAN AND BICYCLE FACILITIES.....	16-1
CHAPTER SEVENTEEN RESURFACING, RESTORATION AND REHABILITATION (3) PROJECTS .....	17-1
APPENDIX A PROJECT NUMBERING SYSTEM.....	A-1
APPENDIX B SELECTED NDOR OPERATING INSTRUCTIONS	
DOT-OI 45-1, Utility Rehabilitation Negotiations .....	B-1
DOT-OI 45-2, Utility and Railroad Payments .....	B-3
DOT-OI 45-5, Agreements .....	B-5
DOT-OI 45-6, Delegation of Authority.....	B-9
DOT-OI 60-9, Corridor Protection .....	B-15
DOT-OI 60-10, ADA Accessibility Requirements in Transportation Projects .....	B-19
DOT-OI 60-11, Municipal Cost Sharing.....	B-29
DOT-OI 60-12, Cost Sharing for Local Roads Crossing Freeways and Expressways .....	B-41
DOT-OI 60-13, Relinquishment of Roads from the Highway System.....	B-43
DOT-OI 60-16, Policy for Phase Constructed 3R Projects .	B-49
DOT-OI 60-19, Use of Proprietary and State Furnished Items.....	B-51
APPENDIX C PUBLIC INTEREST LETTERS .....	C-1
APPENDIX D REQUIREMENTS TO PROVIDE CURB RAMPS.....	D-1
APPENDIX E RURAL INTERCHANGES .....	E-1
APPENDIX F SURVEY/PLAN ACCURACY .....	F-1
APPENDIX G DEGREE OF CURVATURE.....	G-1
APPENDIX H APPLICATION OF DESIGN STANDARDS .....	H-1
APPENDIX I INSTALLATION OF THE BEVELED EDGE .....	I-1
APPENDIX J GUIDELINES FOR ADDRESSING WORKZONE SAFETY .....	J-1
APPENDIX K PROJECT COORDINATION MEETINGS.....	K-1
APPENDIX L PIH REPORT & PQS MEMO FLOODPLAIN WORDING .....	L-1
APPENDIX M 408 PIH REPORT LANGUAGE .....	M-1
GLOSSARY .....	I
INDEX .....	i



# TABLE OF CONTENTS

## CHAPTER ONE ROADWAY DESIGN STANDARDS

1.	STATUTORY AUTHORITY .....	1-1
1.A	<u>Federal Authority</u> .....	1-1
1.A.1	Projects on the National Highway System .....	1-1
1.A.2	3R Freeway Projects on the National Highway System .....	1-1
1.A.3	Projects not on the National Highway System .....	1-1
1.B	<u>State Authority - Board of Public Roads Classifications and Standards</u> .....	1-2
1.B.1	Minimum Design Standards .....	1-2
1.B.2	Flexibility in the Design and Maintenance Standards .....	1-2
1.B.3	Practical Design .....	1-2
1.B.4	3R Standards for Expressways with Access Only at Interchanges .....	1-3
2.	DESIGN STANDARDS .....	1-3
3.	HIGHWAY CLASSIFICATION .....	1-3
3.A	<u>Classification</u> .....	1-3
3.A.1	National Highway Functional Classification Map (Nebraska) .....	1-4
3.A.2	State Highway Functional Classification Map (Nebraska) .....	1-4
4.	HIGHWAY SYSTEMS .....	1-9
4.A	<u>Interstate System</u> .....	1-9
4.B	<u>National Highway System (NHS)</u> .....	1-9
4.C	<u>Strategic Highway Network (STRAHNET)</u> .....	1-9
4.D	<u>National Highway Freight Network</u> .....	1-10
4.E	<u>Nebraska Expressway System</u> .....	1-11
4.F	<u>Nebraska Priority Commercial System</u> .....	1-11
4.G	<u>Nebraska 28 Foot Top System</u> .....	1-11
4.H	<u>Other Nebraska State Highways</u> .....	1-11
5.	CAPITAL IMPROVEMENT VS SYSTEM PRESERVATION .....	1-12
6.	APPLICATION OF DESIGN CRITERIA .....	1-12
6.A	<u>New and Reconstructed Criteria</u> .....	1-12
6.B	<u>Resurfacing, Restoration and Rehabilitation (3R) Criteria</u> .....	1-13
6.B.1	Bridge Rehabilitation (3R) Work .....	1-14
6.C	<u>Maintenance Projects</u> .....	1-14
6.C.1	Routine Maintenance .....	1-14
6.C.1.a	Routine Bridge Maintenance Activities .....	1-15
6.C.2	Preventive Maintenance .....	1-15
6.C.2.a	Bridge Preventive Maintenance Activities .....	1-16
6.D	<u>Safety Improvement Projects</u> .....	1-17

7.	<b>DESIGN CONTROLS</b> .....	1-18
7.A	<b><u>Design Year Forecast Traffic</u></b> .....	1-18
7.B	<b><u>Design Speed</u></b> .....	1-18
7.C	<b><u>Sight Distance</u></b> .....	1-18
7.D	<b><u>Terrain</u></b> .....	1-18
7.E	<b><u>Roadside Design</u></b> .....	1-19
7.F	<b><u>Context (Rural/Municipal)</u></b> .....	1-19
7.G	<b><u>Access Control</u></b> .....	1-20
8.	<b>THE CONTROLLING DESIGN CRITERIA</b> .....	1-21
8.A	<b><u>NDOT Non-Controlling Design Criteria</u></b> .....	1-22
8.B	<b><u>Nominal Shoulder Width for Lateral Offset to Obstruction</u></b> .....	1-23
	8.B.1 Highways With an ADT < 400 VPD .....	1-23
	8.B.2 Highways With an ADT ≥ 400 VPD .....	1-23
8.C	<b><u>NDOT Desirable Design Guidance</u></b> .....	1-26
9.	<b>NDOT FORM 76</b> .....	1-28
9.A	<b><u>Instructions For Completing NDOT Form 76</u></b> .....	1-28
	9.A.1 Sources .....	1-28
	9.A.2 Instructions .....	1-28
10.	<b>DEPARTURE FROM STANDARDS</b> .....	1-32
10.A	<b><u>Design Exceptions for Projects on the NHS and for Risk Based Projects</u></b> .....	1-32
	10.A.1 Oversight Authority for Departure from Standards .....	1-32
	10.A.2 Design Exception Documentation for RBPs for Design .....	1-32
10.B	<b><u>Design Relaxations of the MDS</u></b> .....	1-33
10.C	<b><u>Procedure for When Desirable Conditions Cannot be Attained</u></b> .....	1-34
11.	<b>REFERENCES</b> .....	1-37



# TABLE OF CONTENTS

## CHAPTER TWO ROADWAY DESIGN PROCESS

1.	DESIGN PROCESS OUTLINE .....	2-1
2.	ENGINEERING REVIEW (ACTIVITY 5202) .....	2-2
3.	INITIAL PROJECT REVIEW AND SETUP (ACTIVITY 5308).....	2-2
4.	PRELIMINARY ALIGNMENT DESIGN FOR BRIDGE HYDRAULICS (ACTIVITY 5306/5312) .....	2-4
5.	PRELIMINARY ROADWAY DESIGN (ACTIVITY 5307/5309) .....	2-4
5.A	<u>Obtain Preliminary Data</u> .....	2-4
5.B	<u>Project Scope Review and Scoping Changes</u> .....	2-5
5.C	<u>Begin Preliminary Design</u> .....	2-6
5.D	<u>Request Information from Other Divisions</u> .....	2-6
5.E	<u>Drainage</u> .....	2-8
5.F	<u>Initiate Special Investigations</u> .....	2-8
5.F.1	Additional Survey.....	2-8
5.F.2	Traffic Engineering Review.....	2-8
5.G	<u>Aerial Photo Sheet Preparation</u> .....	2-9
5.H	<u>Utilities on Urban Projects</u> .....	2-9
5.I	<u>Preliminary Access Control Determination</u> .....	2-9
5.J	<u>Review Design Checklist</u> .....	2-9
6.	COST UPDATE 1 - STATUS 30 (ACTIVITY 5403).....	2-10
7.	DESIGN PLAN-IN-HAND (PIH) (ACTIVITY 5315).....	2-10
7.A	<u>Plan-in-Hand Plans</u> .....	2-10
7.B	<u>Plan-in-Hand Plan Distribution</u> .....	2-11
7.C	<u>Conduct the Plan-in-Hand Inspection</u> .....	2-11
8.	PIH REPORT (ACTIVITY 5318/5338).....	2-12
9.	ROADWAY FUNCTIONAL DESIGN (ACTIVITY 5316/5326) .....	2-12
9.A	<u>Special Provisions</u> .....	2-13
9.B	<u>Initiate Agreements</u> .....	2-13
9.B.1	City Agreements.....	2-13
9.B.2	Irrigation Agreements .....	2-14
9.B.3	Railroad Agreements .....	2-14
9.C	<u>Design Access Control</u> .....	2-14
9.D	<u>Receive Additional Documentation</u> .....	2-15
9.E	<u>Notifications</u> .....	2-15
9.F	<u>Design Relaxations</u> .....	2-15
9.G	<u>Submit Functional Plans</u> .....	2-15
10.	COVENANT RELINQUISHMENT AGREEMENT .....	2-16

11. COST UPDATE 2 -STATUS 40 (ACTIVITY 5406).....	2-16
12. DESIGN PREPARATION FOR PUBLIC HEARINGS (ACTIVITY 5323/5324).....	2-17
12.A <u>Public Hearings</u> .....	2-17
12.B <u>Highway Commission Statement</u> .....	2-19
12.C <u>Public Meetings</u> .....	2-19
12.C.1 Public Information Meetings.....	2-21
12.C.2 City and/or County Officials Meeting .....	2-22
12.C.3 Property Owners Pre-Hearing .....	2-22
13. ROADWAY DESIGN (ACTIVITY 5325/5327) .....	2-25
14. ROADWAY DESIGN REVIEW/LIMITS OF CONSTRUCTION PLANS (ACTIVITY 5335/5336) .....	2-25
14.A <u>Limits of Construction Plans</u> .....	2-25
14.B <u>Other Tasks in Activity 5335</u> .....	2-26
15. COST UPDATE 3 - STATUS 45 (ACTIVITY 5408).....	2-26
16. DESIGN REVIEW SUPPORT PROCESSES (ACTIVITY 5340).....	2-27
17. PRELIMINARY RIGHT-OF-WAY PLAN REVIEW (ACTIVITY 5345).....	2-27
17.A <u>Removal Items and Notes</u> .....	2-27
18. DESIGN PLANS TO UTILITIES UNIT (ACTIVITY 5350).....	2-28
19. INFORMATION MEETING PRIOR TO APPRAISAL AND ACQUISITION (ACTIVITY 5314).....	2-28
20. CHANGES TO FINAL DESIGN (ACTIVITY 5355/5357).....	2-28
20.A <u>Check on Other Agreements</u> .....	2-28
21. FINAL RELINQUISHMENT AGREEMENT (FRA) .....	2-29
22. PREPARATION OF FINAL PLANS PACKAGE/FINAL PLAN REVIEW FOR PS&E (ACTIVITY 5369/5368) .....	2-31
22.A <u>Assemble Project Data</u> .....	2-31
22.B <u>Check Earthwork and Notes</u> .....	2-32
22.C <u>Checking Plans for Conflicts</u> .....	2-32
22.D <u>Final Plan Review for PS&amp;E</u> .....	2-33
23. POST LETTING SUPPORT AND PLAN REVISION (ACTIVITY 5375/5376) .....	2-33
23.A <u>Changes to the Design Plans</u> .....	2-33
23.A.1 Plan Revisions.....	2-34
24. ARCHIVING THE PROJECT FILE .....	2-35
25. REFERENCES .....	2-36

# TABLE OF CONTENTS

## CHAPTER THREE ROADWAY ALIGNMENT

1.	SIGHT DISTANCE .....	3-1
2.	HORIZONTAL ALIGNMENT DESIGN.....	3-2
2.A	<u>Maximum Allowable Deflection on a Horizontal Alignment</u> <u>Without a Curve</u> .....	3-2
2.B	<u>Horizontal Curvature</u> .....	3-2
2.B.1	Simple Curves .....	3-2
2.B.2	Reverse Curves .....	3-3
2.B.3	Compound Curves .....	3-3
2.B.4	Broken Back Curves .....	3-3
2.B.5	Spiral Transition Curves .....	3-3
2.C	<u>Superelevation</u> .....	3-5
2.C.1	Transition Lengths .....	3-6
2.C.2	Axis of Rotation.....	3-6
2.C.3	Smoothing of Pavement Edge Profile.....	3-7
2.D	<u>Pavement Widening on Curves (Off-tracking)</u> .....	3-7
3.	VERTICAL ALIGNMENT DESIGN .....	3-21
3.A	<u>Grades</u> .....	3-22
3.A.1	Maximum Grades .....	3-22
3.A.2	Minimum Grades For Drainage .....	3-22
3.A.3	Critical Length of Grade.....	3-22
3.A.4	Climbing Lanes.....	3-22
3.B	<u>Vertical Curves</u> .....	3-24
3.B.1	Vertical Curve Computations .....	3-24
3.B.2	Design .....	3-26
3.C	<u>Crest Vertical Curves</u> .....	3-32
3.C.1	Stopping Sight Distance .....	3-32
3.C.2	Two Lane, Two-Way Roadways - Passing Sight Distance.....	3-33
3.D	<u>Sag Vertical Curves</u> .....	3-34
3.D.1	Stopping Sight Distance .....	3-34
3.D.2	Comfort Criteria.....	3-38
3.D.3	Underpass Sight Distance .....	3-38
3.D.4	Vertical Curve with Obstructions .....	3-38
3.D.4.a	Minimum Vertical Clearances for Overhead Facilities .....	3-38
3.E	<u>Roller-Coaster Profile</u> .....	3-39
4.	COMBINATION OF HORIZONTAL AND VERTICAL ALIGNMENT.....	3-39
5.	ALIGNMENT DESIGN VALUES .....	3-40
5.A	<u>Horizontal Alignment</u> .....	3-40
5.A.1	Station Equations .....	3-40
5.B	<u>Vertical Alignment</u> .....	3-40
6.	REFERENCES .....	3-41



# TABLE OF CONTENTS

## CHAPTER FOUR INTERSECTIONS, DRIVEWAYS AND CHANNELIZATION

1.	<b>INTERSECTIONS</b> .....	4-1
1.A	<b><u>Types of Intersections</u></b> .....	4-2
1.A.1	Unchannelized Intersections .....	4-2
1.A.2	Channelized Intersections .....	4-2
1.A.3	Roundabouts .....	4-3
1.A.4	Reduced Conflict Intersections .....	4-6
1.B	<b><u>Intersection Locations</u></b> .....	4-14
1.B.1	The Intersection of Two State Highways .....	4-14
1.B.2	Rural Intersections .....	4-16
1.B.3	Urban Intersections.....	4-16
1.B.4	Frontage Roads .....	4-17
1.C	<b><u>Intersection Design Considerations</u></b> .....	4-19
1.C.1	Capacity and Level of Service .....	4-19
1.C.2	Intersection Sight Distance .....	4-19
1.C.3	Horizontal Alignment .....	4-20
1.C.3.a	Intersection Skew w/Stop Control on Minor Roadway .....	4-20
1.C.3.b	Intersections on Curved Alignments.....	4-24
1.C.4	Profile.....	4-24
1.C.5	Design Vehicle.....	4-25
1.C.6	Intersection Radius .....	4-25
1.C.6.a	Left Turn Radii .....	4-26
1.C.7	On-Street Parking.....	4-26
1.C.8	Transit Services.....	4-26
1.C.9	Signs .....	4-27
1.C.10	Pedestrian Crosswalks .....	4-27
1.C.11	Bike Lane - Highway Intersections.....	4-27
1.C.12	Railroad Crossings .....	4-27
1.D	<b><u>Turn Lanes</u></b> .....	4-27
1.D.1	Turn Lane Length .....	4-31
1.D.2	Turn Lane Bay Taper Rate .....	4-31
1.D.3	Offset Right-Turn Lanes .....	4-32
1.D.4	Turning Roadways at Intersections (Free-Flow Right-Turn Lanes).....	4-34
1.E	<b><u>Traffic Control</u></b> .....	4-34
1.E.1	Unsignalized Intersections .....	4-34
1.E.2	Signalized Intersections .....	4-35
2.	<b>DRIVEWAYS</b> .....	4-35
2.A	<b><u>Rural Driveways</u></b> .....	4-36
2.A.1	Rural Driveway Culvert Pipes.....	4-39
2.A.2	Hydraulic Design of Driveway Culverts .....	4-39
2.B	<b><u>Urban Driveways</u></b> .....	4-41

<b>3.</b>	<b>SURFACING .....</b>	<b>4-43</b>
<b>3.A</b>	<b><u>Intersection Surfacing Guidelines</u> .....</b>	<b>4-43</b>
<b>3.B</b>	<b><u>Driveway Surfacing Guidelines</u>.....</b>	<b>4-43</b>
<b>4.</b>	<b>BUILD NOTES FOR INTERSECTIONS AND DRIVEWAYS .....</b>	<b>4-46</b>
<b>5.</b>	<b>CHANNELIZATION .....</b>	<b>4-47</b>
<b>5.A</b>	<b><u>Islands</u>.....</b>	<b>4-50</b>
<b>5.A.1</b>	<b>Raised Islands .....</b>	<b>4-50</b>
<b>5.B</b>	<b><u>Medians</u>.....</b>	<b>4-51</b>
<b>5.B.1</b>	<b>Median Uses .....</b>	<b>4-51</b>
<b>5.B.2</b>	<b>Median Types.....</b>	<b>4-51</b>
<b>5.B.3</b>	<b>Median Width.....</b>	<b>4-52</b>
<b>5.B.4</b>	<b>Median Breaks .....</b>	<b>4-53</b>
<b>5.B.4.a</b>	<b>Type A Median Breaks .....</b>	<b>4-53</b>
<b>5.B.4.b</b>	<b>Type B Median Breaks .....</b>	<b>4-53</b>
<b>5.B.4.c</b>	<b>Type C Median Breaks .....</b>	<b>4-54</b>
<b>5.B.4.d</b>	<b>Type D Median Breaks .....</b>	<b>4-54</b>
<b>6.</b>	<b>REFERENCES .....</b>	<b>4-71</b>

# TABLE OF CONTENTS

## CHAPTER FIVE INTERSTATES, GRADE SEPARATIONS, AND INTERCHANGES

1.	<b>INTERSTATE SYSTEM</b> .....	5-2
1.A	<b><u>Interstate Design Values</u></b> .....	5-2
1.B	<b><u>Design Controls</u></b> .....	5-2
	1.B.1 Design Year .....	5-2
	1.B.2 Design Speed.....	5-2
	1.B.3 Design Vehicle.....	5-2
1.C	<b><u>Alignment</u></b> .....	5-2
1.D	<b><u>The Typical Interstate Cross-Section</u></b> .....	5-3
1.E	<b><u>Earthwork</u></b> .....	5-3
1.F	<b><u>Interstate Surfacing</u></b> .....	5-3
1.G	<b><u>Guardrail and Roadside Barriers</u></b> .....	5-8
1.H	<b><u>Miscellaneous Interstate Design Issues</u></b> .....	5-8
	1.H.1 Fencing .....	5-8
	1.H.2 Utilities .....	5-8
	1.H.3 Water Quality .....	5-8
	1.H.4 Left-in-Place Median Crossovers .....	5-8
	1.H.5 Rest Areas and Weigh Stations.....	5-9
1.I	<b><u>Interstate Plans</u></b> .....	5-9
1.J	<b><u>Right-Of-Way/Access Control</u></b> .....	5-9
1.K	<b><u>Interstate Pedestrian and Bicycle Facilities</u></b> .....	5-9
1.L	<b><u>Drainage Design</u></b> .....	5-9
1.M	<b><u>3R Interstate Projects</u></b> .....	5-9
2.	<b>GRADE SEPARATIONS AND INTERCHANGES</b> .....	5-11
2.A	<b><u>FHWA Design Discipline Support Tool for Interchanges</u></b> .....	5-12
2.B	<b><u>General Interchange Design Considerations</u></b> .....	5-12
2.C	<b><u>Interchange Warrants</u></b> .....	5-13
2.D	<b><u>Adaptability of Highway Grade Separations and Interchanges</u></b> .....	5-13
2.E	<b><u>Grade Separation Structures</u></b> .....	5-14
	2.E.1 Underpass Roadways .....	5-14
	2.E.1.a Roadway Cross-Section .....	5-14
	2.E.1.b Underpass Sight Distance.....	5-14
	2.E.1.c Vertical Clearance.....	5-14
	2.E.2 Overpass Roadways .....	5-14
	2.E.2.a Roadway Cross-Section.....	5-14
	2.E.3 Local Roads Crossing Freeways and Expressways .....	5-15
2.F	<b><u>Interchange Configurations</u></b> .....	5-15
	2.F.1 Single Point Urban Interchange .....	5-15
	2.F.2 Diverging Diamond Interchange.....	5-15
2.G	<b><u>Pedestrian and Bicycle Accommodation at Interchanges</u></b> .....	5-19
2.H	<b><u>Interchange Spacing</u></b> .....	5-19
2.I	<b><u>Interchange Lighting</u></b> .....	5-19

3.	<b>RAMPS</b>	5-19
3.A	<b><u>Ramp Types</u></b>	5-20
3.B	<b><u>General Ramp Design Considerations</u></b>	5-20
3.C	<b><u>Spiral Transition Curves</u></b>	5-24
3.D	<b><u>Additional NDOT Ramp Considerations</u></b>	5-26
4.	<b>REFERENCES</b>	5-27



# TABLE OF CONTENTS

## CHAPTER SIX THE TYPICAL ROADWAY CROSS-SECTION

1.	THE TRAVELED WAY .....	6-2
1.A	<u>Travel Lane Widths</u> .....	6-2
1.B	<u>Travel Lane Cross Slopes</u> .....	6-2
2.	SHOULDERS .....	6-2
2.A	<u>Shoulder Width and Type</u> .....	6-2
2.A.1	Priority Commercial System Width .....	6-3
2.A.2	Installation of Two-Foot Surface Shoulders on Lower Volume Roads .....	6-4
2.B	<u>Shoulder Cross Slopes</u> .....	6-5
2.C	<u>Beveled Edge</u> .....	6-5
3.	CURBS.....	6-16
3.A	<u>Curb Warrants</u> .....	6-16
3.B	<u>Curb Types</u> .....	6-17
3.C	<u>Curb Design Considerations</u> .....	6-19
4.	ROLLOVER RATES.....	6-22
5.	TRANSITION.....	6-22
6.	AUXILIARY LANES .....	6-24
7.	ROADWAY CHANNELIZATION .....	6-24
8.	NEW FOUR-LANE DIVIDED HIGHWAY USING EXISTING TWO-LANE HIGHWAY (2 + 2 PROJECTS).....	6-24
9.	ROADSIDE DESIGN .....	6-25
9.A	<u>The Clear Zone</u> .....	6-25
9.A.1	Horizontal Clear Zone .....	6-25
9.A.2	Fixed Obstacle Clearance .....	6-25
9.A.3	Clear Zone Requirements for Auxiliary Lanes .....	6-25
9.B	<u>Roadside Geometry (Side Slopes)</u> .....	6-26
9.B.1	Fill Slopes (Parallel) .....	6-26
9.B.2	Fill Slopes (Transverse).....	6-27
9.B.3	Cut Slopes .....	6-27
10.	OTHER ELEMENTS AFFECTING THE ROADWAY CROSS-SECTION.....	6-30
10.A	<u>Right-of-Way</u> .....	6-30
10.B	<u>Drainage</u> .....	6-30
10.C	<u>Environmental Considerations</u> .....	6-31
10.D	<u>Erosion Control</u> .....	6-31
10.E	<u>Geotechnical Features</u> .....	6-32
10.F	<u>Snow Control</u> .....	6-32

10.G	<u>Earthwork Balances</u> .....	6-32
10.H	<u>Daylighting</u> .....	6-32
10.I	<u>Utilities</u> .....	6-33
10.J	<u>Guardrail</u> .....	6-33
10.K	<u>Bridges</u> .....	6-33
	10.K.1 Underpasses.....	6-33
11.	REFERENCES .....	6-34

# TABLE OF CONTENTS

## CHAPTER SEVEN EARTHWORK

1.	<b>EARTHWORK</b> .....	7-1
1.A	<b><u>Computations</u></b> .....	7-2
1.A.1	<b>Balance Factors</b> .....	7-3
1.A.2	<b>Distribution Analysis</b> .....	7-3
1.A.2.a	<b>Haul Considerations</b> .....	7-5
1.A.3	<b>Moisture Content</b> .....	7-5
1.B	<b><u>Borrow Pits and Waste Sites</u></b> .....	7-7
1.B.1	<b>Alternatives to Providing Borrow or Waste Sites</b> .....	7-7
1.B.1.a	<b>Borrow Alternatives</b> .....	7-7
1.B.1.b	<b>Waste Alternatives</b> .....	7-8
1.C	<b><u>Removal of Existing Surfacing</u></b> .....	7-8
1.C.1	<b>Rural Projects</b> .....	7-8
1.C.2	<b>Urban Projects</b> .....	7-9
2.	<b>STAGED CONSTRUCTION/PHASING</b> .....	7-9
3.	<b>MISCELLANEOUS EARTHWORK CONSIDERATIONS</b> .....	7-10
3.A	<b><u>Bridge Replaced with a Box Culvert</u></b> .....	7-10
3.B	<b><u>Unsuitable Materials</u></b> .....	7-10
3.C	<b><u>Contaminated Soils</u></b> .....	7-10
3.D	<b><u>Need for Additional Cross-Sections</u></b> .....	7-11
3.E	<b><u>Shear Lines</u></b> .....	7-13
4.	<b>METHODS OF PAYMENT</b> .....	7-16
4.A	<b><u>"Excavation" and "Excavation-Borrow"</u></b> .....	7-16
4.B	<b><u>"Established Quantities"</u></b> .....	7-16
4.B.1	<b>"Earthwork Measured in Embankment" and "Excavation (Established Quantity)"</b> .....	7-16
4.C	<b><u>Roadway Grading</u></b> .....	7-17
4.D	<b><u>Driveways and Field Entrances</u></b> .....	7-17
4.E	<b><u>Subsidiary Earthwork</u></b> .....	7-17
5.	<b>EXAMPLE CALCULATIONS</b> .....	7-18
5.A	<b><u>Case 1: Embankment (Fill) Only</u></b> .....	7-19
5.B	<b><u>Case 2: Unbalanced - Mostly Embankment</u></b> .....	7-20
5.B.1	<b>Case 2.A: More Embankment than Excavation in Urban Areas</b> .....	7-21
5.C	<b><u>Case 3: Considerable Borrow</u></b> .....	7-21
5.D	<b><u>Case 4: Balanced - No Borrow</u></b> .....	7-23
5.E	<b><u>Case 5: Excavation or Embankment in Urban Areas and on Rural Projects with Low Volumes of Earthwork</u></b> .....	7-24
5.E.1	<b>Case 5.A: More Excavation than Embankment in Urban Areas</b> .....	7-24
5.E.2	<b>Case 5.B: More Excavation than Embankment on a Rural Project with Low Volumes of Earthwork</b> .....	7-25
6.	<b>REVIEWING EARTHWORK COMPUTATIONS AND CROSS-SECTIONS</b> .....	7-27

7.	FINALIZING ROADWAY EARTHWORK FOR PAYMENT .....	7-27
8.	SOIL, SUBGRADE AND SITUATION REPORTS .....	7-29
8.A	<u>Soil Survey/Soil and Situation Report</u> .....	7-29
8.A.1	Soil Survey.....	7-29
8.A.2	Preliminary Soil and Situation Report.....	7-29
8.A.3	Soil and Situation Report.....	7-30
8.B	<u>Subgrade Survey/Subgrade and Situation Report</u> .....	7-30
8.B.1	Subgrade Survey.....	7-30
8.B.2	Subgrade and Situation Report.....	7-31
8.C	<u>Embankment Foundation Report</u> .....	7-31
8.C.1	Settlement Surcharge .....	7-32
9.	REFERENCES .....	7-33

# TABLE OF CONTENTS

## CHAPTER EIGHT SURFACING

1.	PAVEMENT DESIGN DETERMINATION.....	8-1
1.A	<u>Pavement Design Input</u> .....	8-1
1.B	<u>Pavement Determination Development</u> .....	8-1
2.	PAVEMENT TYPES .....	8-2
2.A	<u>Rigid (Concrete) Pavement</u> .....	8-2
2.A.1	Portland Cement Concrete Pavement Design Policy.....	8-2
2.A.2	Pavement Joints.....	8-3
2.A.2.a	Policy for Longitudinal Joints.....	8-4
2.A.3	Joining Existing Pavement.....	8-4
2.A.4	Tining.....	8-4
2.B	<u>Flexible Pavement</u> .....	8-4
2.C	<u>Surfacing Aggregates</u> .....	8-4
3.	PAVEMENT SUBDRAINS.....	8-5
4.	SHOULDERS .....	8-6
4.A	<u>Concrete Shoulders</u> .....	8-6
4.B	<u>Asphalt Shoulders</u> .....	8-6
4.C	<u>Earth Shoulder Construction</u> .....	8-6
5.	PAVEMENT REHABILITATION.....	8-9
5.A	<u>Types of Rehabilitation</u> .....	8-9
5.B	<u>Removal of Existing Surfacing</u> .....	8-9
5.B.1	Cold Milling.....	8-9
5.B.2	Brick Removal .....	8-9
5.B.3	Concrete Surface Milling .....	8-9
5.C	<u>Concrete Repair and Bituminous Pavement Patching</u> .....	8-10
5.D	<u>Overlays and Transitions</u> .....	8-10
5.D.1	Template Correction.....	8-10
5.D.2	Superelevation Improvement .....	8-10
5.E	<u>Pavement Dropoffs During Construction</u> .....	8-10
6.	SURFACING QUANTITY COMPUTATIONS.....	8-11
6.A	<u>Rigid Pavement</u> .....	8-11
6.B	<u>Flexible Pavement</u> .....	8-12
6.C	<u>Surfacing Aggregates</u> .....	8-12
6.D	<u>Foundation, Base and Surface Courses</u> .....	8-13
6.E	<u>Sawing Pavement</u> .....	8-13
7.	RUMBLE STRIPS AND RUMBLE STRIPES.....	8-13
7.A	<u>Shoulder Rumble Strips</u> .....	8-14
7.B	<u>Edgeline Rumble Stripes</u> .....	8-15
7.C	<u>Centerline Rumble Stripes</u> .....	8-16

<b>8. BEVELED EDGE.....</b>	<b>8-16</b>
<b>9. SURFACING ELEVATIONS.....</b>	<b>8-16</b>
<b>10. REFERENCES .....</b>	<b>8-17</b>

# TABLE OF CONTENTS

## CHAPTER NINE GUARDRAIL AND ROADSIDE BARRIERS

1.	BARRIER JUSTIFICATION.....	9-2
1.A	<u>Determination of the Clear-Zone Distance</u> .....	9-2
1.B	<u>Identification of the Roadside Condition</u> .....	9-2
1.C	<u>Consideration of Your Options</u> .....	9-2
1.D	<u>Performance of a Cost Effectiveness Analysis</u> .....	9-4
2.	BARRIER TYPES USED IN NEBRASKA .....	9-4
3.	GUARDRAIL DESIGN PROCEDURES .....	9-6
3.A	<u>Determine Runout Length &amp; Lateral Extent of the Obstacle</u> .....	9-7
3.B	<u>Plot the Runout Path</u> .....	9-10
3.C	<u>Determine the Appropriate Flare Rate(s)</u> .....	9-13
3.D	<u>Select the Guardrail Components</u> .....	9-13
3.D.1	<u>Deflection Distance</u> .....	9-14
3.E	<u>Graphically Locate the Guardrail on the Plan</u> .....	9-14
3.F	<u>Design the Earthwork Around the Guardrail</u> .....	9-17
3.G	<u>Determine the Details of Surfacing Under the Guardrail</u> .....	9-17
4.	END TREATMENTS.....	9-21
4.A	<u>Guardrail End Treatment, Type I</u> .....	9-21
4.B	<u>Guardrail End Treatment, Type II</u> .....	9-21
4.C	<u>Guardrail End Treatment, Type TL2 (for Low-Speed Roadways)</u> .....	9-21
4.D	<u>End Anchorage Assembly</u> .....	9-21
4.E	<u>Bullnose</u> .....	9-21
5.	BRIDGE APPROACH SECTIONS .....	9-21
6.	MEDIAN BARRIERS .....	9-25
6.A	<u>Median Barrier Systems</u> .....	9-26
7.	SPECIAL INSTALLATIONS.....	9-37
7.A	<u>Guardrail at Intersections</u> .....	9-37
7.B	<u>Guardrail Over Low Fill Culverts</u> .....	9-37
7.C	<u>Guardrail Spans with Posts Eliminated</u> .....	9-37
7.D	<u>MGS Installed Near Slopes</u> .....	9-38
7.E	<u>Guardrail and Curbs</u> .....	9-39
8.	CRASH CUSHIONS AND IMPACT ATTENUATORS .....	9-41
8.A	<u>Inertial Barriers</u> .....	9-41
9.	DETERMINE THE PAY ITEM QUANTITIES.....	9-44
10.	REFERENCES .....	9-45





# TABLE OF CONTENTS

## CHAPTER TEN MISCELLANEOUS DESIGN ISSUES

1.	RAILROADS .....	10-1
1.A	<u>Railroad/Highway Grade Crossings</u> .....	10-2
1.A.1	<u>Railroad/Highway Crossing Surfacing</u> .....	10-3
2.	BRIDGE STRUCTURES .....	10-6
2.A	<u>Horizontal Curvature</u> .....	10-6
2.B	<u>Skewed Structures</u> .....	10-7
2.C	<u>Bridge Grades</u> .....	10-8
2.D	<u>Vertical Curvature</u> .....	10-8
2.E	<u>Vertical Clearances</u> .....	10-8
	2.E.1 <u>Grade Separations</u> .....	10-8
	2.E.2 <u>Stream Crossings</u> .....	10-9
2.F	<u>Intersections</u> .....	10-9
2.G	<u>High Embankments</u> .....	10-9
3.	AIRWAY HIGHWAY CLEARANCES .....	10-12
3.A	<u>Nebraska Division of Aeronautics</u> .....	10-12
3.B	<u>Federal Aviation Administration</u> .....	10-12
3.C	<u>NEPA Coordination</u> .....	10-14
4.	LANDSCAPING .....	10-18
4.A	<u>Tree Planting and Removal</u> .....	10-19
4.B	<u>Roundabout Landscaping</u> .....	10-19
5.	SNOW CONTROL.....	10-20
6.	FENCING .....	10-21
7.	CATTLE PASSES .....	10-22
8.	RETAINING WALLS .....	10-22
9.	OLD ROAD OBLITERATION.....	10-22
10.	MAILBOX TURNOUTS AND SUPPORTS .....	10-23
11.	RURAL MEDIAN MAINTENANCE TURNAROUNDS .....	10-24

12. UTILITIES.....	10-25
12.A <u>Utility Liaison</u> .....	10-25
12.B <u>Utility Rehabilitation Plan Review</u> .....	10-25
12.C <u>City/County Utility Cost Reimbursement</u> .....	10-26
12.D <u>Utility Accommodation on State Highway Right-of-Way</u> .....	10-26
12.D.1 Aerial Lines.....	10-27
12.D.2 Underground Electrical Power and Communication Lines .....	10-28
12.D.3 Pipelines .....	10-29
12.D.4 Water Mains .....	10-30
13. ROADWAY LIGHTING.....	10-31
13.A <u>Guidelines for the Installation of Roadway Lighting</u> .....	10-31
13.A.1 Urban Lighting.....	10-31
13.A.1.a Warrants.....	10-31
13.A.1.b Festoon Outlets .....	10-32
13.A.1.c Costs .....	10-32
13.A.2 Rural Intersection Lighting .....	10-32
13.A.2.a Warrants.....	10-32
13.A.2.b Costs .....	10-33
13.A.3 Rural Continuous Lighting .....	10-33
13.A.4 Interchange Lighting.....	10-33
14. PARKING.....	10-34
13.A <u>Accessible Parking</u> .....	10-34
15. REFERENCES .....	10-37

# TABLE OF CONTENTS

## CHAPTER ELEVEN HIGHWAY PLANS ASSEMBLY

1.	DESIGN PLANS.....	11-1
1.A	<u>Preliminary Design Plans (Phase 3: Design - Activity 5300)</u> .....	11-2
1.B	<u>Functional Design Plans (Phase 4: Environmental Approval - Activity 5400)</u> .....	11-2
1.C	<u>Design Detail Plans (Phase 5: Plan Details - Activity 5500)</u> .....	11-3
1.D	<u>Design Plans to Utility Unit (Phase 6: R.O.W. - Activity 5600)</u> .....	11-3
1.D.1	Pre-PS&E Plans (Phase 7: Plan-Package - Activity 5700).....	11-4
1.E	<u>Plans for Construction</u> .....	11-4
1.E.1	PS&E Plans (Phase 7: Plan Package - Activity 5700).....	11-4
1.E.2	PS&E Letting Plans (Phase 8: Letting - Activity 5800).....	11-4
2.	STANDARD PLANS, SPECIAL PLANS AND DETAILS.....	11-5
2.A	<u>Standard Plans</u> .....	11-5
2.B	<u>Standardized Special Plans</u> .....	11-5
2.C	<u>Special Plans</u> .....	11-5
2.D	<u>Standard Typical Cross-Sections</u> .....	11-6
2.E	<u>Information</u> .....	11-6
2.F	<u>Standard Details</u> .....	11-6
2.G	<u>Design Guides</u> .....	11-6
3.	STANDARD FORMATS.....	11-7
3.A	<u>Plan Border Sheets</u> .....	11-7
3.B	<u>Standard Symbols</u> .....	11-7
3.C	<u>Construction Notes</u> .....	11-7
3.D	<u>Horizontal Alignment Data</u> .....	11-8
3.E	<u>Vertical Alignment Data</u> .....	11-9
3.F	<u>Drainage and Hydraulic Information</u> .....	11-10
3.F.1	New and Reconstructed Projects.....	11-10
3.F.2	3R Projects.....	11-10
3.G	<u>Plan Sheet Scales</u> .....	11-11
3.G.1	Urban.....	11-11
3.G.2	Rural.....	11-11
4.	PLAN SET ORGANIZATION.....	11-11
4.A	<u>Title Sheet (A)</u> .....	11-18
4.B	<u>The Typical Cross-Section Sheets (B)</u> .....	11-18
4.C	<u>Summary of Quantities Sheets (C)</u> .....	11-20
4.D	<u>Soil and Materials Survey Information Sheets (D)</u> .....	11-20
4.E	<u>Environmental or Aerial Sheets (E)</u> .....	11-20
4.F	<u>Alignment and Control Point Sheets (F)</u> .....	11-21
4.G	<u>General Information Sheets (G)</u> .....	11-21
4.H	<u>Phasing Plan Sheets (H)</u> .....	11-21
4.J	<u>Large Scale Plan Sheets (J)</u> .....	11-22
4.J.1	Concrete Surfacing Elevations and Grades.....	11-22
4.K	<u>Utilities Plan Sheets (K)</u> .....	11-25

4.L	<u>Plan, Plan over Plan, or Plan and Profile Sheets (L)</u> .....	11-25
4.M	<u>Traffic Plan Sheets (M)</u> .....	11-26
4.N	<u>Roadway Lighting Plan Sheets (N)</u> .....	11-26
4.O	<u>Intelligent Transportation System (ITS) Project Plan Sheets (O)</u> .....	11-26
4.P	<u>SWPPP, Landscaping, and Erosion &amp; Sediment Control Plan Sheets (P)</u> .....	11-26
4.Q	<u>Earthwork Data Sheets (Q)</u> .....	11-26
4.R	<u>Drainage Structure Cross-Section Sheets (R)</u> .....	11-27
4.S	<u>Bridge Plans (S)</u> .....	11-28
4.T	<u>Bridge Special Plans (T)</u> .....	11-28
4.U	<u>Roadway Special Plan Sheets (U)</u> .....	11-28
4.V	<u>Other Plans as Needed (V)</u> .....	11-28
4.W	<u>Right-Of-Way Plan Sheets (W)</u> .....	11-28
4.X	<u>Roadway Cross-Sections (X)</u> .....	11-29
5.	<b>PROFESSIONAL ENGINEER SEAL AND SIGNATURE</b> .....	11-30
6.	<b>ADDENDUMS TO A PROJECT</b> .....	11-30
7.	<b>REVISIONS TO A PROJECT</b> .....	11-30
7.A	<u>Federal Oversight Projects</u> .....	11-32
	7.A.1 <u>FHWA Plan Revision Approval Process</u> .....	11-32
7.B	<u>Revision Procedures</u> .....	11-33
	7.B.1 <u>Revised Sheet</u> .....	11-35
	7.B.2 <u>Added Sheet</u> .....	11-35
	7.B.3 <u>Deleted Sheet</u> .....	11-36
	7.B.4 <u>Quantity and/or Pay Item Changes</u> .....	11-36
	7.B.5 <u>Detail Sheet</u> .....	11-36
7.C	<u>Revising a Project Which Has Been Rejected or Withdrawn From a Letting</u> .....	11-42
	7.C.1 <u>Title Sheet (Project Has Been Rejected or Withdrawn From a Letting)</u> .....	11-42
8.	<b>REFERENCES</b> .....	11-43

# TABLE OF CONTENTS

## CHAPTER TWELVE COST ESTIMATING & FUNDING

1.	USES OF COST ESTIMATES.....	12-1
1.A	<u>Planning, Allocation and Funding</u> .....	12-1
1.B	<u>Design Alternative Comparisons</u> .....	12-2
1.C	<u>Bid Comparison and Analysis</u> .....	12-2
1.D	<u>Agreements</u> .....	12-2
1.E	<u>Railroad Protective Liability Insurance</u> .....	12-2
1.F	<u>NEPA</u> .....	12-2
1.G	<u>Public Meetings</u> .....	12-2
2.	FUNDING AND COST SHARING.....	12-3
2.A	<u>Federal Funding Programs</u> .....	12-3
2.A.1	National Highway Performance Program (NHPP) .....	12-3
2.A.2	Surface Transportation Block Grant Program (STBG) .....	12-3
2.A.3	Highway Safety Improvement Program (HSIP).....	12-3
2.A.4	Rail Highway Crossings (RRZ) .....	12-3
2.B	<u>Statewide Transportation Improvement Program (STIP)</u> .....	12-4
2.C	<u>Federal Funding - Participating</u> .....	12-4
2.C.1	Salvaging Items .....	12-4
2.D	<u>Federal Funding - Nonparticipating Items</u> .....	12-5
2.E	<u>State of Nebraska Funding</u> .....	12-5
2.F	<u>Participation by Others</u> .....	12-5
2.F.1	Utilities .....	12-5
2.F.2	Railroad.....	12-5
2.G	<u>Funding Splits Defined by Stations</u> .....	12-6
2.G.1	Lump Sum Funding Splits .....	12-6
3.	SOURCES OF PROJECT INFORMATION .....	12-6
3.A	<u>Integrated Highway Inventory System</u> .....	12-6
3.B	<u>Highway Improvement Programming Request (NDOT Form 73)</u> .....	12-6
4.	SCHEDULE OF ESTIMATES IN ACTIVITY SEQUENCE .....	12-7
4.A	<u>General</u> .....	12-7
4.B	<u>Level of Detail</u> .....	12-7
5.	ESTIMATE REQUEST FORMS.....	12-9
5.A	<u>Project Information Sheet (NDOT Form 342)</u> .....	12-9
5.B	<u>Project Quantity Sheet (NDOT Form 343)</u> .....	12-9
6.	COST ESTIMATE REQUEST PROCEDURES .....	12-10
6.A	<u>Routing from the Roadway Designer</u> .....	12-10
6.B	<u>Timeliness</u> .....	12-10
6.C	<u>Change in Project Scope or Concept</u> .....	12-10
6.D	<u>Estimate Review</u> .....	12-10

<b>7.</b>	<b>CONTENTS OF COST ESTIMATES .....</b>	<b>12-11</b>
7.A	<u>Preliminary Engineering</u> .....	12-11
7.B	<u>Right-of-Way</u> .....	12-12
	7.B.1 Land Values .....	12-12
	7.B.1.a Rural .....	12-12
	7.B.1.b Urban .....	12-12
	7.B.2 Fences.....	12-13
	7.B.3 Improvements.....	12-13
	7.B.4 Relocation Assistance .....	12-13
	7.B.5 Other Right-of-Way Costs.....	12-13
7.C	<u>Utilities</u> .....	12-14
7.D	<u>Railroad</u> .....	12-14
7.E	<u>Construction Engineering</u> .....	12-14
7.F	<u>Contingencies</u> .....	12-14
7.G	<u>Construction Items</u> .....	12-15
	7.G.1 Mobilization .....	12-15
	7.G.2 Specifications and Special Provisions .....	12-15
	7.G.3 Standard Pay Items .....	12-16
	7.G.4 New Materials .....	12-16
	7.G.4.a Sole Sourcing.....	12-17
	7.G.5 Quantities.....	12-17
	7.G.6 Traffic Control Items .....	12-19
	7.G.7 Bridge Items .....	12-20
	7.G.8 Other Construction Items .....	12-22
<b>8.</b>	<b>ITEMS AFFECTING CONSTRUCTION COSTS.....</b>	<b>12-22</b>
8.A	<u>Construction Schedule</u> .....	12-22
8.B	<u>Construction Location</u> .....	12-22
	8.B.1 Site Specific Features .....	12-22
	8.B.2 Urban/Rural.....	12-22
8.C	<u>Maintaining Traffic During Construction</u> .....	12-23
<b>9.</b>	<b>ITEMS OFTEN OVERLOOKED OR OMITTED .....</b>	<b>12-23</b>
<b>10.</b>	<b>REFERENCES .....</b>	<b>12-43</b>

# TABLE OF CONTENTS

## CHAPTER THIRTEEN PLANNING AND PROJECT DEVELOPMENT

1.	INTRODUCTION AND GENERAL CONSIDERATIONS .....	13-1
2.	PLANNING AND SCHEDULING .....	13-2
3.	ENGINEERING REVIEW AND LOCATION STUDIES .....	13-2
3.A	<u>Engineering Review</u> .....	13-2
3.B	<u>Location Studies</u> .....	13-3
4.	PROJECT COORDINATION MEETINGS.....	13-4
5.	ENVIRONMENTAL STUDIES .....	13-6
5.A	<u>Environmental Classification and Documentation</u> .....	13-6
5.A.1	Environmental Classification .....	13-6
5.A.2	4(f) Evaluation (Publicly Owned Lands/Historic Places) .....	13-7
5.A.3	6(f) Lands (Land Water Conservation Funds Used For Park Improvements.....	13-7
5.B	<u>Wetlands and Section 404 Permits</u> .....	13-8
5.B.1	Wetlands Definitions .....	13-8
5.B.2	Wetlands Procedures .....	13-8
5.B.3	Public Notification of Wetland Mitigation .....	13-12
5.B.4	Section 404 Permits .....	13-14
5.B.5	Section 10 of the Rivers and Harbors Act .....	13-15
5.B.6	Channel Changes .....	13-15
5.B.6.a	Bridge Channel Work .....	13-16
5.B.7	Floodplains .....	13-16
5.B.8	Water Quality .....	13-17
5.C	<u>Air Quality</u> .....	13-17
5.D	<u>Noise</u> .....	13-17
5.E	<u>Wildlife Issues</u> .....	13-18
5.F	<u>Social, Economic, and Environmental Impacts</u> .....	13-19
5.G	<u>Archeological and Historical Features</u> .....	13-19
5.H	<u>Hazardous Materials</u> .....	13-20
5.H.1	Materials Prohibited or Restricted as Fill Materials .....	13-20
5.H.2	Guidelines for Handling Petroleum Tanks/Leaks on Construction Projects .....	13-20
5.H.3	Guidelines for Handling Contaminated Soils on Highway Right-of-Way .....	13-21
6.	LIAISON WITH OTHER AGENCIES AND ORGANIZATIONS .....	13-22
6.A	<u>Agreements</u> .....	13-22
6.B	<u>Federal Agencies</u> .....	13-22
6.C	<u>Other State Agencies</u> .....	13-22
6.D	<u>Local and Regional Agencies</u> .....	13-22
6.E	<u>Public Participation and Input</u> .....	13-22
6.F	<u>Consultants</u> .....	13-23
7.	REFERENCES .....	13-24





# TABLE OF CONTENTS

## CHAPTER FOURTEEN TRAFFIC

1.	TRAFFIC ENGINEERING STUDIES .....	14-1
1.A	<u>Capacity Analysis</u> .....	14-1
1.B	<u>Safety Analysis</u> .....	14-1
1.C	<u>Volume Studies</u> .....	14-2
1.D	<u>At-Grade vs. Interchange Recommendations</u> .....	14-2
1.E	<u>Weaving Section Analysis</u> .....	14-2
1.F	<u>Lane Configuration</u> .....	14-2
1.G	<u>Traffic Control Studies</u> .....	14-2
1.H	<u>Pedestrian Crossings</u> .....	14-3
2.	ROADWAY SIGNS .....	14-3
3.	MARKINGS .....	14-4
4.	TRAFFIC SIGNALS .....	14-5
4.A	<u>Pedestrian Signals</u> .....	14-5
5.	INTELLIGENT TRANSPORTATION SYSTEM .....	14-6
6.	WORK ZONE TRAFFIC CONTROL .....	14-7
6.A	<u>Construction Under Traffic</u> .....	14-7
6.A.1	Crossovers .....	14-8
6.A.2	Temporary Surfacing .....	14-8
6.B	<u>Temporary Roads</u> .....	14-9
6.C	<u>Identification of Work Zone "Significant Projects"</u> .....	14-13
6.D	<u>Detours</u> .....	14-14
7.	REFERENCES .....	14-16



# TABLE OF CONTENTS

## CHAPTER FIFTEEN RIGHT-OF-WAY

1.	RIGHT-OF-WAY SURVEY .....	15-1
2.	RIGHT-OF-WAY DESIGN PLANS .....	15-1
2.A	<u>Existing Plans</u> .....	15-1
2.B	<u>Corridor Protection Plans</u> .....	15-2
2.C	<u>Ownership Plans</u> .....	15-3
2.D	<u>Preliminary Right-of-Way Plans</u> .....	15-3
2.D.1	Right-of-Way Design .....	15-4
2.D.2	Permanent Easements .....	15-4
2.D.3	Temporary Easements .....	15-4
2.D.4	Railroad Easements, Rights or Leases.....	15-5
2.D.5	ROW Design Review .....	15-5
2.D.6	Preliminary ROW Estimate .....	15-5
2.E	<u>Appraisal Plans</u> .....	15-5
2.F	<u>Negotiation Plans</u> .....	15-5
2.G	<u>PS&amp;E Plans</u> .....	15-6
2.H	<u>Plan Changes/Revisions</u> .....	15-6
3.	ACCESS CONTROL .....	15-7
3.A	<u>Access Control Design</u> .....	15-8
3.B	<u>Access Control on the Interstate, Freeways and Expressways</u> <u>(Access Only at Interchanges)</u> .....	15-12
3.C	<u>Access Control on Expressways and</u> <u>Other Four-Lane Divided Highways</u> .....	15-12
3.D	<u>Access Control on All Other Highways</u> .....	15-12
3.E	<u>Access Control on Side Streets and Roads</u> .....	15-13
3.F	<u>Public Notification</u> .....	15-13
4.	APPRAISAL.....	15-19
5.	ACQUISITION .....	15-19
5.A	<u>Contract Preparation</u> .....	15-19
5.B	<u>Condemnation</u> .....	15-19
5.C	<u>Relocation Assistance</u> .....	15-19
6.	RIGHT-OF-WAY CERTIFICATION.....	15-20
6.A	<u>Public Interest Letters</u> .....	15-20
7.	MISCELLANEOUS.....	15-24
7.A	<u>Right-of-Way Markers</u> .....	15-24
7.B	<u>Re-establishing Land Monuments and Property Corners</u> .....	15-24
7.C	<u>Fencing</u> .....	15-24
7.D	<u>Relinquishment and Abandonment</u> .....	15-25
8.	REFERENCES .....	15-26



# TABLE OF CONTENTS

## CHAPTER SIXTEEN PEDESTRIAN AND BICYCLE FACILITIES

1. RESOURCE PUBLICATIONS.....	16-1
2. DEFINITIONS.....	16-2
3. BIKEWAYS AND SHARED USE PATHS.....	16-4
4. SIDEWALKS.....	16-5
4.A <u>Sidewalk Design Considerations</u> .....	16-5
5. PEDESTRIAN UNDERPASSES.....	16-7
6. PEDESTRIAN CROSSINGS .....	16-7
7. CURB RAMPS .....	16-8
8. ACCESSIBLE ON-STREET PARKING.....	16-11
9. PEDESTRIAN RAMPS.....	16-11
10. STEPS AND STAIRS .....	16-12
11. HANDRAILS FOR PEDESTRIAN RAMPS AND STAIRS .....	16-12
12. PEDESTRIAN ACCESS DURING CONSTRUCTION.....	16-13
12.A <u>Pedestrian Access Review</u> .....	16-13
12.B <u>Example Special Provisions</u> .....	16-15
13. ADA UPGRADES - COST SHARING .....	16-15
14. REFERENCES .....	16-16



# TABLE OF CONTENTS

## CHAPTER SEVENTEEN RESURFACING, RESTORATION AND REHABILITATION (3R) PROJECTS

1.	<b>3R DESIGN STANDARDS AND GUIDELINES</b> .....	17-3
1.A	<b><u>3R Versus Other Work Types</u></b> .....	17-3
1.B	<b><u>3R Design Controls</u></b> .....	17-5
	1.B.1 Design Year Forecast Traffic .....	17-5
	1.B.2 Design Speed .....	17-5
1.C	<b><u>Bridge Rehabilitation (3R) Work</u></b> .....	17-5
1.D	<b><u>Interstate NHS 3R Projects</u></b> .....	17-6
	1.D.1 Wyoming to Big Springs (0+00 to 102+00) .....	17-6
	1.D.2 Colorado to Grand Island (102+00 to 312+10) .....	17-6
	1.D.3 Grand Island to Lincoln (312+10 to 395+62) .....	17-7
	1.D.4 Lincoln to Omaha (395+62 to 455+31) .....	17-7
1.E	<b><u>3R Standards for Expressways with Access Only at Interchanges</u></b> .....	17-8
1.F	<b><u>2+2 Projects</u></b> .....	17-11
	1.F.1 2+2 Project Safety .....	17-11
	1.F.2 2+2 Project Bridges .....	17-11
	1.F.3 2+2 Project Lighting .....	17-11
	1.F.4 2+2 Cross-Section Alternatives .....	17-12
1.G	<b><u>Super 2 Projects</u></b> .....	17-12
	1.G.1 Objectives of Adding Passing Lanes .....	17-12
	1.G.2 Location Guidelines for Passing Lanes .....	17-12
	1.G.3 Geometric Design of Passing Lanes .....	17-13
	1.G.4 Average Passing Lane Spacing .....	17-14
1.H	<b><u>Practical Design: Bridge or Culvert Replacement Projects</u></b> .....	17-17
	1.H.1 Standards and Intent .....	17-17
2.	<b>3R DESIGN PROCESS</b> .....	17-19
2.A	<b><u>Initial Processing of Asset Preservation Projects</u></b> .....	17-19
2.B	<b><u>Asset Preservation Templates</u></b> .....	17-19
2.C	<b><u>Preliminary Roadway Design</u></b> .....	17-20
2.D	<b><u>Plan-in-Hands</u></b> .....	17-20
3.	<b>ROADWAY ALIGNMENT</b> .....	17-21
3.A	<b><u>Vertical Alignment Design</u></b> .....	17-21
	3.A.1 Vertical Curve .....	17-21
	3.A.2 Grade .....	17-21
	3.A.3 Vertical Taper Rates .....	17-22
3.B	<b><u>Horizontal Alignment Design</u></b> .....	17-22
	3.B.1 Superelevation .....	17-23
	3.B.2 Pavement Widening on Curves .....	17-23
	3.B.3 Traffic Control Devices for Horizontal Alignment .....	17-24

4.	INTERSECTIONS, DRIVEWAYS AND CHANNELIZATION .....	17-25
4.A	<u>Driveways and Intersections</u> .....	17-25
4.B	<u>Raised Medians</u> .....	17-26
5.	INTERCHANGES AND GRADE SEPARATIONS .....	17-26
6.	THE TYPICAL ROADWAY CROSS-SECTION .....	17-27
6.A	<u>Initial Roadway Assumption for 3R and Analysis of Alternatives</u> .....	17-27
6.B	<u>The Traveled Way</u> .....	17-28
6.C	<u>Shoulders</u> .....	17-28
6.D	<u>The 3R Project Clear Zone</u> .....	17-29
6.E	<u>Foreslopes and Other Slopes, Earth Dikes, and Mailbox Turnouts</u> .....	17-30
6.F	<u>Turn Lanes and Auxiliary Lanes</u> .....	17-31
7.	EARTHWORK.....	17-32
8.	SURFACING .....	17-33
8.A	<u>Mainline Surfacing Taper Rate</u> .....	17-33
8.B	<u>Rumble Strips, Edgeline Rumble Stripes, and Centerline Rumble Stripes</u> .....	17-33
8.C	<u>Beveled Edge</u> .....	17-33
8.D	<u>Surfacing Quantities</u> .....	17-33
9.	GUARDRAIL AND ROADSIDE BARRIERS .....	17-34
9.A	<u>Within the 3R Project Clear Zone</u> .....	17-34
9.B	<u>Cost-Effectiveness Analysis</u> .....	17-34
9.C	<u>Roadside Barriers and End Treatments</u> .....	17-35
10.	MISCELLANEOUS DESIGN ISSUES .....	17-37
10.A	<u>Railroads</u> .....	17-37
10.B	<u>Bridges</u> .....	17-37
10.C	<u>Temporary Roads</u> .....	17-38
10.D	<u>Lighting</u> .....	17-38
10.E	<u>Agreements/Cost Sharing</u> .....	17-38
	10.E.1 Agreements .....	17-38
	10.E.2 Letter of Notification .....	17-39
10.F	<u>Utilities</u> .....	17-39
	10.F.1 Preliminary Utility Inspection Report.....	17-39
	10.F.2 Utility Potholing .....	17-40
	10.F.3 Plan-in-Hand Report.....	17-40
	10.F.4 Utility Status 45 Estimate.....	17-40
	10.F.5 Status of Utilities .....	17-41
11.	HIGHWAY PLANS ASSEMBLY.....	17-41
12.	COST ESTIMATING & FUNDING .....	17-41
13.	PROJECT DEVELOPMENT .....	17-42
13.A	<u>Wetland Impacts and Environmental Permits</u> .....	17-42
13.B	<u>Environmental Classification</u> .....	17-42
13.C	<u>Floodplains</u> .....	17-42



14. TRAFFIC .....	17-43
15. RIGHT-OF-WAY .....	17-43
16. PEDESTRIAN AND BICYCLE FACILITIES .....	17-44
17. DRAINAGE DESIGN AND EROSION CONTROL.....	17-45
17.A <u>Culverts and Hydraulic Considerations</u> .....	17-45
17.B <u>Concrete Box Culverts</u> .....	17-45
17.C <u>Pipe Culverts</u> .....	17-46
17.C.1 Headwall Removal.....	17-46
17.C.2 Pipe Extension.....	17-46
17.D <u>Floodplains</u> .....	17-47
17.E <u>Seeding &amp; Erosion Control</u> .....	17-48
18. REFERENCES .....	17-49



# LIST OF EXHIBITS

## CHAPTER ONE ROADWAY DESIGN STANDARDS

Exhibit 1.1	Rural Highway Functional Classifications .....	1-5
Exhibit 1.2	Municipal Highway Functional Classifications .....	1-7
Exhibit 1.3	Lateral Offset to Obstruction – New and Reconstructed Projects .....	1-24
Exhibit 1.4	Lateral Offset to Obstruction – Resurfacing, Restoration and Rehabilitation (3R) projects.....	1-25
Exhibit 1.5	Example NDOT Form 76 .....	1-30
Exhibit 1.6	Example Design Exception Request Letter.....	1-35
Exhibit 1.7	Example Design Decision Documentation Sheet .....	1-36



# **LIST OF EXHIBITS**

## **CHAPTER TWO ROADWAY DESIGN PROCESS**

<b>Exhibit 2.1</b>	<b>Initial Project Scoping Data Sheet .....</b>	<b>2-3</b>
<b>Exhibit 2.2</b>	<b>Plan and Agreement Requirements for Public Meetings .....</b>	<b>2-20</b>
<b>Exhibit 2.3</b>	<b>Public Hearing Notice Worksheet.....</b>	<b>2-23</b>
<b>Exhibit 2.4</b>	<b>Resolution and Petition Form .....</b>	<b>2-30</b>



# LIST OF EXHIBITS

## CHAPTER THREE ROADWAY ALIGNMENT

Exhibit 3.1	Elements of a Simple Curve .....	3-4
Exhibit 3.2	Superelevation Rates.....	3-5
Exhibit 3.3	Superelevation Data for Crowned Highways .....	3-8
Exhibit 3.4	Superelevation Data for Dual Highways (Crowned Surface) .....	3-12
Exhibit 3.5	Superelevation Data for Dual Highways (Tangent Surface).....	3-15
Exhibit 3.6	Superelevation for Dual Highways w/Raised Median .....	3-18
Exhibit 3.7	Standards for Climbing Lanes .....	3-23
Exhibit 3.8	Elements and Formulas for Symmetrical Parabolic Vertical Curves .....	3-25
Exhibit 3.9	Design Controls for Crest Vertical Curves.....	3-27
Exhibit 3.10	Eye and Object Heights used to Determine Desirable K Values.....	3-29
Exhibit 3.11	Crest Vertical Curve Design Elements .....	3-33
Exhibit 3.12	Passing Sight Distance Design Considerations .....	3-33
Exhibit 3.13	Sag Vertical Curve Design Elements.....	3-35
Exhibit 3.14	Design Controls for Sag Vertical Curves .....	3-36
Exhibit 3.15	Roller Coaster Profile .....	3-39





# LIST OF EXHIBITS

## CHAPTER FOUR INTERSECTIONS, DRIVEWAYS AND CHANNELIZATION

Exhibit 4.1	Typical Elements of a Roundabout Intersection.....	4-3
Exhibit 4.2	Roundabout Intersection – Typical Truck Apron Curb Arrangement.....	4-5
Exhibit 4.3	Typical Reduced Conflict Intersection .....	4-6
Exhibit 4.4	Intersection Sight Distances for a RCI .....	4-10
Exhibit 4.5	RCI Example Island Details .....	4-12
Exhibit 4.6	RCI Example Loon Details.....	4-13
Exhibit 4.7	Design Guidance for the Intersection of Two Rural Two-Lane State Highways .....	4-15
Exhibit 4.8	Flow Chart for Roadway Widths of Frontage Roads and Access Roads .....	4-17
Exhibit 4.9	Typical Frontage Road Connection off of a Main Roadway.....	4-18
Exhibit 4.10	Typical Frontage Road Connection off of a Crossroad.....	4-19
Exhibit 4.11	Skew Angle Definition .....	4-20
Exhibit 4.12	Intersection Realignment Design .....	4-21
Exhibit 4.13	Guidelines for the Selection of Intersection/Driveway Design Vehicles ...	4-25
Exhibit 4.14	Typical Auxiliary Lanes .....	4-29
Exhibit 4.15	18 Foot Median, Left-Turn Lane .....	4-30
Exhibit 4.16	Tapered Offset Right-Turn Lane .....	4-33
Exhibit 4.17	Rural Driveway Width Criteria.....	4-36
Exhibit 4.18	Rural Driveway Without a Special Ditch.....	4-37
Exhibit 4.19	Rural Driveway With a Special Ditch .....	4-38
Exhibit 4.20	Minimum Rural Driveway Culvert Pipe Lengths .....	4-40
Exhibit 4.21	Urban Driveway Width Criteria.....	4-41
Exhibit 4.22	Urban Driveway.....	4-42
Exhibit 4.23	Limits of Surfacing at Co. Road Intersections and Other Public Roads.....	4-44
Exhibit 4.24	Surfacing Criteria for Rural Driveways.....	4-45
Exhibit 4.25	Example of Rural Three-Leg Intersection with Minor Roadway Without Surfaced Shoulder .....	4-48
Exhibit 4.26	Example of Rural Three-Leg Intersection with Minor Roadway With Surfaced Shoulder.....	4-49
Exhibit 4.27	Median Types .....	4-52
Exhibit 4.28	Desirable Lane Change and Deceleration Distances .....	4-54
Exhibit 4.29	Typical Median Breaks (18 Ft. Raised Medians) .....	4-55
Exhibit 4.30	Typical Type A Median Break (28 Ft. Raised Median) .....	4-56
Exhibit 4.31	Typical Types B and C Median Breaks (28 Ft. Raised Medians).....	4-57
Exhibit 4.32	Typical Type A Median Break (40 Ft. Depressed Median) .....	4-58
Exhibit 4.33	Typical Type B Median Break (40 Ft. Depressed Median) .....	4-59
Exhibit 4.34	Typical Types C and D Median Breaks (40 Ft. Depressed Median) .....	4-60
Exhibit 4.35	Typical Type A Median Break (50 Ft. Depressed Median).....	4-61
Exhibit 4.36	Typical Type B Median Break (50 Ft. Depressed Median).....	4-62
Exhibit 4.37	Typical Type C-1 Median Break (50 Ft. Depressed Median).....	4-63
Exhibit 4.38	Typical Type C-2 Median Break (50 Ft. Depressed Median).....	4-64
Exhibit 4.39	Typical Type D Median Break (50 Ft. Depressed Median).....	4-65
Exhibit 4.40	Typical Type A Median Break (54 Ft. Depressed Median).....	4-66
Exhibit 4.41	Typical Type B Median Break (54 Ft. Depressed Median).....	4-67

<b>Exhibit 4.42</b>	<b>Typical Type C-1 Median Break (54 Ft. Depressed Median)</b> .....	<b>4-68</b>
<b>Exhibit 4.43</b>	<b>Typical Type C-2 Median Break (54 Ft. Depressed Median)</b> .....	<b>4-69</b>
<b>Exhibit 4.44</b>	<b>Typical Type D Median Break (54 Ft. Depressed Median)</b> .....	<b>4-70</b>

# LIST OF EXHIBITS

## CHAPTER FIVE INTERSTATES, GRADE SEPARATIONS, AND INTERCHANGES

Exhibit 5.1	Typical Section – Rural Four-Lane Divided Interstate with Depressed Median (Crowned Roadway) .....	5-4
Exhibit 5.2	Typical Section – Rural Four-Lane Divided Interstate with Depressed Median (Tangent Roadway).....	5-5
Exhibit 5.3	Typical Section – Rural Six-Lane Divided Interstate with Depressed Median (Crowned Roadway) .....	5-6
Exhibit 5.4	Typical Side Slopes for New and Reconstructed Interstates and Interchange Ramps.....	5-7
Exhibit 5.5	Control of Access Along Intercepting Public Roads and Highways Interstate, Freeway and Expressway (Access only at Interchanges) .....	5-10
Exhibit 5.6	Common Interchange Configurations.....	5-16
Exhibit 5.7	Single Point Urban Interchange (SPUI) .....	5-18
Exhibit 5.8	Diverging Diamond Interchange (DDI) .....	5-18
Exhibit 5.9	Typical Section of an Interchange Ramp – One Lane .....	5-22
Exhibit 5.10	Typical Section of an Interchange Ramp –Two Lane.....	5-23
Exhibit 5.11	Components of a Spiral Curve, Spiral In, Spiral Out of Equal Length .....	5-24
Exhibit 5.12	Spiral Curve Information, Spiral In, Spiral Out of Equal Length .....	5-25
Exhibit 5.13	Stationing for Ramps and Loops .....	5-26



# LIST OF EXHIBITS

## CHAPTER SIX THE TYPICAL ROADWAY CROSS-SECTION

Exhibit 6.1	Typical Section - Rural Four-Lane Divided Expressway with 54 ft. Depressed Median (Crowned Roadway) .....	6-6
Exhibit 6.2	Typical Section - Rural Four-Lane Divided Expressway with 54 ft. Depressed Median (Tangent Roadway) .....	6-7
Exhibit 6.3	Typical Section - Rural Major Arterial 4,000 ADT and Over .....	6-8
Exhibit 6.4	Typical Section - Rural Major Arterial 1,000 to 3,999 ADT.....	6-9
Exhibit 6.5	Typical Section - Rural Major Arterial 400 to 999 ADT .....	6-10
Exhibit 6.6	Typical Section - Rural Major Arterial Under 400 ADT .....	6-11
Exhibit 6.7	Typical Half-Section of a Tangent Multi-Lane Divided Highway with Future Lanes in the Depressed Median.....	6-12
Exhibit 6.8	Typical Half-Sections of Two-Lane Low-Speed Municipal Highways .....	6-13
Exhibit 6.9	Typical Half-Sections of Three-Lane and Five-Lane Undivided Low-Speed Municipal Highways with Two-Way Left Turn Lanes .....	6-14
Exhibit 6.10	Typical Half-Section of a Four-Lane Divided Low-Speed Municipal Highway with a Twenty Feet Raised Median .....	6-15
Exhibit 6.11	Teardrop Island on Side Road - Allowable Curb Types .....	6-18
Exhibit 6.12	Typical Curb Details .....	6-20
Exhibit 6.13	Erosion Control Curb Location.....	6-21
Exhibit 6.14	Examples of Rural to Urban Roadway Transitions.....	6-23
Exhibit 6.15	Clear Zone Application for Auxiliary Lanes Adjacent to Mainline .....	6-26
Exhibit 6.16	Typical Side Slopes for New and Reconstructed Projects.....	6-28
Exhibit 6.17	Daylighting .....	6-33



# LIST OF EXHIBITS

## CHAPTER SEVEN EARTHWORK

Exhibit 7.1	Earthwork Computation Formula.....	7-2
Exhibit 7.2	Existing Pavement Removal in Earthwork.....	7-4
Exhibit 7.3	Map for Estimating Water Needed for Compaction .....	7-6
Exhibit 7.4	Earthwork at a Bridge Replaced with a Box Culvert.....	7-10
Exhibit 7.5	Additional Cross-Sections at a Mailbox Turnout.....	7-12
Exhibit 7.6	Additional Cross-Sections at an Intersection or Commercial Driveway ...	7-12
Exhibit 7.7	Shear Lines .....	7-13
Exhibit 7.8	Example Grading Pay Items.....	7-18
Exhibit 7.9	Additional Requirements for Earthwork Calculations.....	7-18
Exhibit 7.10	Earthwork Quantities - Case 1 .....	7-19
Exhibit 7.11	Earthwork Quantities - Case 2 .....	7-20
Exhibit 7.12	Earthwork Quantities - Case 3 .....	7-23
Exhibit 7.13	Earthwork Quantities - Case 4 .....	7-23
Exhibit 7.14	Earthwork Quantities - Case 5A.....	7-24
Exhibit 7.15	Earthwork Quantities - Case 5B.....	7-26
Exhibit 7.16	Earthwork Checklist .....	7-28





# LIST OF EXHIBITS

## CHAPTER EIGHT SURFACING

Exhibit 8.1	Typical Shoulder Construction .....	8-7
-------------	-------------------------------------	-----



# LIST OF EXHIBITS

## CHAPTER NINE GUARDRAIL AND ROADSIDE BARRIERS

Exhibit 9.1	Barrier Considerations for Roadside Conditions .....	9-3
Exhibit 9.2	Nebraska Barrier Summary .....	9-5
Exhibit 9.3	Runout Length Values .....	9-7
Exhibit 9.4	Determine the Runout Length & Lateral Extent of Obstacle .....	9-8
Exhibit 9.5	Plot the Runout Path.....	9-11
Exhibit 9.6	Graphically Locate the Guardrail Components on the Plan .....	9-15
Exhibit 9.7	Example W-Beam or Thrie-Beam Guardrail Design: 2-Lane, 2-Way Curved Roadway: $R > 2950'$ .....	9-18
Exhibit 9.8	Example W-Beam or Thrie Beam Guardrail Design: 2-Lane, 2-Way Curved Roadway: $R \leq 2950'$ .....	9-19
Exhibit 9.9	Example Low-Tension Cable Guardrail Design: 2-Lane, 2-Way Tangent Roadway.....	9-20
Exhibit 9.10	Example Guardrail Design at a Bridge: 2-Lane, 2-Way Tangent Roadway.....	9-22
Exhibit 9.11	Example Guardrail Design at a Bridge: 2-Lane, 2-Way Curved Roadway; $R > 2950'$ .....	9-23
Exhibit 9.12	Example Guardrail Design at a Bridge: 2-Lane, 2-Way Curved Roadway; $R \leq 2950'$ .....	9-24
Exhibit 9.13	Cable Barrier B/C Ratios .....	9-25
Exhibit 9.14	Guidelines for Median Barriers .....	9-26
Exhibit 9.15	Example Guardrail Design - 4 Lane Divided Highway: 54 Feet and Wider Median Width .....	9-28
Exhibit 9.16	Example Guardrail Design - 4 Lane Divided Highway: 40 Feet Median Width .....	9-29
Exhibit 9.17	Example Pier Protection Guardrail Design - 4 Lane Divided Highway: 40 Feet and Wider Median Width .....	9-30
Exhibit 9.18	Example Bullnose Installation for Median Bridge Pier Protection .....	9-31
Exhibit 9.19	Example Bullnose Bridge Connection in a 40 Feet Wide Median: Tapered Bullnose, Bridges not Connected .....	9-32
Exhibit 9.20	Example Bullnose Bridge Connection in a 40 Feet Wide Median: Parallel Bullnose, Bridges not Connected .....	9-33
Exhibit 9.21	Example Bullnose Bridge Connection in a 40 Feet Wide Median: Tapered Bullnose, Bridges Connected.....	9-34
Exhibit 9.22	Example Bullnose Bridge Connection in a 40 Feet Wide Median: Right-Hand-Back Skew, Tapered Bullnose, Bridges Connected .....	9-35
Exhibit 9.23	Example Bullnose Bridge Connection in a 40 Feet Wide Median: Left-Hand-Back Skew, Tapered Bullnose, Bridges Connected.....	9-36
Exhibit 9.24	Details for 31 inch MGS Near Slopes.....	9-38
Exhibit 9.25	Guardrail Installed Behind a Six-Inch Curb on a Low-Speed ( $\leq 45$ mph) Roadway .....	9-39
Exhibit 9.26	Dropping the Curb in Advance of the Guardrail .....	9-40
Exhibit 9.27	Impact Attenuator Installation at a Bridge Adjacent to an Intersection or Driveway (Protection of Bridge Railing Only).....	9-42
Exhibit 9.28	Typical Impact Attenuator Installations .....	9-43



# LIST OF EXHIBITS

## CHAPTER TEN MISCELLANEOUS DESIGN ISSUES

Exhibit 10.1	Railroad/Highway Grade Crossing.....	10-4
Exhibit 10.2	Railroad/Highway Grade Crossing.....	10-5
Exhibit 10.3	Skew Angle Definition.....	10-7
Exhibit 10.4	Minimum Vertical Clearances for Structures.....	10-8
Exhibit 10.5	Vertical Stream Clearances for Crest Profile.....	10-10
Exhibit 10.6	Vertical Stream Clearances for Sag or Level Profile.....	10-11
Exhibit 10.7	Four Mile Airport Envelope.....	10-15
Exhibit 10.8	Runway Protected Area .....	10-16
Exhibit 10.9	Runway Slope Protection .....	10-17
Exhibit 10.10	Parking Stall Dimensions for Curb and Street Parking.....	10-35
Exhibit 10.11	Parking Stall Dimensions for Parking Lots and Garages .....	10-36



# LIST OF EXHIBITS

## CHAPTER ELEVEN HIGHWAY PLANS ASSEMBLY

Exhibit 11.1	Plan Sheet Organization .....	11-12
Exhibit 11.2	Distribution/Notification of Plans Availability .....	11-13
Exhibit 11.3	Typical Cross Section (B) Sheet .....	11-19
Exhibit 11.4	Surfacing Elevations .....	11-23
Exhibit 11.5	Roadway Cross-Section Break Lines .....	11-29
Exhibit 11.6	Example Revision Letter .....	11-34
Exhibit 11.7	Deleted Sheet .....	11-37
Exhibit 11.8	Revised Index Sheet .....	11-38
Exhibit 11.9	Revised Title Sheet .....	11-39
Exhibit 11.10	Revised Summary Sheet .....	11-40
Exhibit 11.11	Revised Detail Sheet.....	11-41





# LIST OF EXHIBITS

## CHAPTER TWELVE COST ESTIMATING & FUNDING

Exhibit 12.1	Cost Estimate Submittals .....	12-8
Exhibit 12.2	Preliminary Cost Estimate Values/Cost Factors .....	12-11
Exhibit 12.3	Quantity Calculation Guidance Locations .....	12-18
Exhibit 12.4	Dimensions to Use in Calculating Area of Bridge Structures .....	12-21
Exhibit 12.5	Estimate Items Often Overlooked or Omitted.....	12-24
Exhibit 12.6	Pay Item Accuracy.....	12-28
Exhibit 12.7	Rounding of Surfacing Item Quantities .....	12-28
Exhibit 12.8	Cost Estimate Item Checklist.....	12-29
Exhibit 12.9	Pavement Item Checklist .....	12-33
Exhibit 12.10	Quantity Computations for Gravel and Crushed Rock .....	12-34
Exhibit 12.11	Estimating Quantities.....	12-35
Exhibit 12.12	Performance Graded Binder Table.....	12-41
Exhibit 12.13	Hydrated Lime/Warm Mix Asphalt.....	12-41
Exhibit 12.14	Asphaltic Concrete Tonnage Table .....	12-42



# **LIST OF EXHIBITS**

## **CHAPTER THIRTEEN PLANNING AND PROJECT DEVELOPMENT**

<b>Exhibit 13.1</b>	<b>Project Coordination Meeting Timeline .....</b>	<b>13-5</b>
<b>Exhibit 13.2</b>	<b>Sample Environmental Summary Sheet.....</b>	<b>13-10</b>
<b>Exhibit 13.3</b>	<b>Pay Limits for Bridge Channel Work .....</b>	<b>13-16</b>



# LIST OF EXHIBITS

## CHAPTER FOURTEEN TRAFFIC

Exhibit 14.1	Example Temporary Road .....	14-11
Exhibit 14.2	Typical Temporary Road Section .....	14-12



# LIST OF EXHIBITS

## CHAPTER FIFTEEN RIGHT-OF-WAY

Exhibit 15.1	Typical Access Control at Joint Driveways .....	15-8
Exhibit 15.2	Example Control Access Letter .....	15-10
Exhibit 15.3	Desirable and Minimum Access Locations .....	15-14
Exhibit 15.4	Control of Access Along Intercepting Public Roads and Highways Interstate, Freeway and Expressway (Access only at Interchanges) ...	15-15
Exhibit 15.5	Control of Access Along Intercepting Public Roads and Highways 2-Lane Highway.....	15-16
Exhibit 15.6	Control of Access Along Intercepting Public Roads and Highways Divided Highway .....	15-17
Exhibit 15.7	Control of Access Along Intercepting Public Roads and Highways Skewed Intersection .....	15-18
Exhibit 15.8	Example Public Interest Letter.....	15-22





# LIST OF EXHIBITS

## CHAPTER SIXTEEN PEDESTRIAN AND BICYCLE FACILITIES

Exhibit 16.1	Sidewalk and Shared Use Path Minimum Widths .....	16-4
Exhibit 16.2	Typical Sidewalk Section .....	16-6
Exhibit 16.3	Fencing on Steep Slopes Adjacent to a Sidewalk .....	16-6
Exhibit 16.4	Curb Ramp Counter Slopes .....	16-10
Exhibit 16.5	Typical Section of a Pedestrian Ramp .....	16-11
Exhibit 16.6	Typical Handrail Extension at a Pedestrian Ramp .....	16-13



# LIST OF EXHIBITS

## CHAPTER SEVENTEEN RESURFACING, RESTORATION AND REHABILITATION (3R) PROJECTS

Exhibit 17.1	3R Standards for Expressway (Access Only at Interchanges) .....	17-9
Exhibit 17.2	Optimal Lengths of Passing Lanes.....	17-14
Exhibit 17.3	Average Passing Lane Spacing (mi) Needed to Meet Specific LOS Targets on Two-Lane Highways in Level Terrain .....	17-15
Exhibit 17.4	Average Passing Lane Spacing (mi) Needed to Meet Specific LOS Targets on Two-Lane Highways in Rolling Terrain .....	17-16
Exhibit 17.5	Build Up Strategy vs Build Out Strategy .....	17-27
Exhibit 17.6	Comparative Barrier Consideration for Embankments .....	17-36



The information contained in the Introduction, dated May 2022, has been updated to reflect the January 2023 Errata. The errata addresses errors, changes in procedure, changes in NDOT department titles, changes in other Roadway Design Manual chapters and other reference material citations occurring since the latest publication of this chapter.

# Introduction

## 1. MANUAL UPDATES

The date given in the header (May 2022 for the Introduction) is the date that the individual Chapter was approved for use by the **FHWA**. The Errata date (the date of the latest update/correction of the chapter) is found below the header. The Roadway Design Manual is updated periodically as circumstances warrant, generally between two and four times a year.

This manual may be found on the internet at:

<http://www.roads.nebraska.gov/business-center/design-consultant/rd-manuals/>

## 2. PURPOSE OF MANUAL

This manual has been developed to provide guidance and assistance to the roadway designer and other **Nebraska Department of Transportation (NDOT)** personnel in the practices and procedures for the detailed design of roadways and the preparation of contract plans. The manual has been developed to meet the following principal objectives:

- Document **NDOT** guidelines with regard to design criteria and practices for the development of plans
- Define design criteria to guide judgments and decisions made by **Roadway Design Division** personnel
- Describe the coordination necessary to develop plans in a timely and cost effective manner
- Describe the most current and effective design techniques and practices and to present charts, tables and other information useful to designers.

## 3. HOW TO USE THE MANUAL

This manual has been written to provide information for both the new designer and for the more experienced designer. General guidelines and design practices are described. For more detailed explanation of the topics, references are provided for the reader.

It should be noted that the **NDOT** design criteria presented in this book generally conforms to the guidelines of the **American Association of State Highway and Transportation Officials (AASHTO)** in publications such as **AASHTO's A Policy on Geometric Design of Highways and Streets**. In some instances, where nationwide guidelines do not fit Nebraska conditions, **NDOT** design practice differs from **AASHTO** guidelines. For those situations **NDOT** guidelines take precedence over **AASHTO's** guidelines. However, if the **NDOT** design criteria cannot be attained the designer should follow **AASHTO's** guidelines.

**NDOT** and the **Board of Public Roads Classifications and Standards** have developed the Nebraska Minimum Design Standards (MDS). These standards represent *minimum* design values. Higher values should be used. The designer should contact his/her supervisor if **NDOT** standards cannot be met because a relaxation of the *MDS* will be required and design exception approval may be required (See Chapter One: Roadway Design Standards, Section 10, of this manual).

Throughout the manual, the words "shall", "should", and "may" are used to describe the appropriate application of various design techniques. The following definitions describe the proper application of these terms:

- "Shall" is a mandatory condition; the designer will make every practical effort to follow the criteria. If it is impractical to follow the "shall" criteria, the designer needs to obtain **Assistant Design Engineer** approval and document the decision made, or obtain authorization for a design exception or a relaxation of the *MDS* (See Chapter One: Roadway Design Standards, Section 10, of this manual).
- "Should" is an advisory condition; the designer is recommended, not mandated, to follow the criteria. For situations where it is impractical to follow the "should" criteria, the designer needs to obtain **Assistant Design Engineer** approval and document the decision made (See Chapter One: Roadway Design Standards, Section 10, of this manual)."
- "May" is a permissive condition; it is recommended that the designer make reasonable efforts to follow the design criteria. For situations where it is impractical to follow the "may" criteria, the designer does not need authorization for design variances.

Several formatting conventions have been used in the manual to aid the designer in locating information. When Exhibits are discussed in the text, the titles are highlighted, e.g., EXHIBIT 1.1. Individuals, sections, divisions, and other organizations with which interaction may be required appear in bold lettering, e.g., **Roadway Design Division Engineer**. References to material in other chapters of this manual are shown as: Chapter One: Roadway Design Standards, for example, with pertinent sections noted as appropriate.

#### 4. SOURCES OF INFORMATION

The primary sources of roadway design guidance and standards for **NDOT** are A Policy on Geometric Design of Highways and Streets (Green Book), A Policy on Design Standards Interstate System (I-State Green Book), the *MDS*, and this manual. Other sources of information are listed in the REFERENCES section found at the back of each Chapter. Suppliers of construction materials also may be used as sources of information for special design problems such as special culverts, retaining walls, impact attenuators, etc.

Where possible, Internet connections have been given for reference materials cited in this manual. This connection will follow the first citation of a document in a chapter and will also appear in the REFERENCES section found at the back of the Chapter.

The information contained in Chapter One: Roadway Design Standards, dated May 2022, has been updated to reflect the October 2023 Errata. The errata addresses errors, changes in procedure, changes in NDOT department titles, changes in other Roadway Design Manual chapters and other reference material citations occurring since the latest publication of this chapter.

Chapter One presents guidance for the design of New, Reconstructed and 3R projects: additional design guidance for 3R projects is provided in Chapter Seventeen.

# Chapter One

## Roadway Design Standards

### 1. STATUTORY AUTHORITY

#### 1.A Federal Authority

##### 1.A.1 **Projects on the National Highway System**

Section 109(c) of Title 23, United States Code (U.S.C.) (<https://www.gpo.gov/fdsys/pkg/USCODE-2011-title23/html/USCODE-2011-title23-chap1-sec109.htm>) provides that design and construction standards for new construction and reconstruction on the National Highway System (NHS) and for resurfacing, restoring, and rehabilitating multi-lane limited access highways on the National Highway System shall be those approved by the United States Secretary of Transportation in cooperation with the State highway departments. In a similar manner, 23 U.S.C. 109(b) provides standards for the Interstate system.

##### 1.A.2 **3R Freeway Projects on the National Highway System**

January 3, 2022 amendments to 23 CFR 625 include the following summary:  
([Fed-Register-2021-28236.pdf \(localassistanceblog.com\)](#))

“FHWA amends its regulations governing design standards and standard specifications applicable to new construction, reconstruction, resurfacing (except for maintenance resurfacing), restoration, and rehabilitation projects on the National Highway System (NHS). In issuing this final rule, FHWA will allow State departments of transportation (State DOT) to adopt procedures or design criteria, as approved by FHWA, that enable the State to undertake resurfacing, restoration, and rehabilitation (RRR) projects on freeways, including Interstate highways, without utilizing design exceptions as long as the RRR procedures or criteria are met. In addition, FHWA incorporates by reference the latest versions of design standards and standard specifications previously adopted and incorporated by reference and removes from its regulations the corresponding outdated or superseded versions of these standards and specifications.”

##### 1.A.3 **Projects not on the National Highway System**

Title 23 of the Code of Federal Regulations (23 CFR), Section 625.3(a)(2) (<https://www.gpo.gov/fdsys/pkg/CFR-2011-title23-vol1/pdf/CFR-2011-title23-vol1-sec625-3.pdf>) states that “Federal-aid projects not on the NHS are to be designed, constructed, operated, and maintained in accordance with State laws, regulations, directives, safety standards, design standards, and construction standards.”

## 1.B State Authority – Board of Public Roads Classifications and Standards

### 1.B.1 Minimum Design Standards

The Nebraska Revised Statutes have authorized the **Board of Public Roads Classifications and Standards (Board)** to develop minimum standards of design, construction, and maintenance for each functional classification set forth in Sections 39-2103 and 39-2104 (<https://nebraskalegislature.gov/laws/browse-chapters.php?chapter=39>). The **Nebraska Department of Transportation (NDOT)** is required to abide by these standards. If it is not practicable to meet the minimum design standards, a relaxation of the Nebraska Minimum Design Standards must be requested (See Section 10 of this chapter).

### 1.B.2 Flexibility in the Design and Maintenance Standards

March 2019 amendments to the Nebraska Revised Statutes, Section 39-2113 include the following:

(7) In cooperation with the Department of Transportation, counties, and municipalities, the board is authorized to develop, support, approve, and implement programs and project strategies that provide additional flexibility in the design and maintenance standards. Once a program is established, the board shall allow project preapproval for all projects that conform to the agreed-upon program. The programs shall be set out in memorandums of understanding or guidance documents and may include, but are not limited to, the following:

- a) Practical design, flexible design, or similar programs or strategies intended to focus funding on the primary problem or need in constructing projects that will not meet all the standards but provide substantial overall benefit at a reasonable cost to the public;
- b) Asset preservation or preventative maintenance programs and strategies that focus on extending the life of assets, such as, but not limited to, pavement and bridges that may incorporate benefit cost, cost effectiveness, best value, or lifecycle analysis in determining the project approach and overall benefit to the public; and
- c) Context sensitive design programs or similar programs that consider the established needs and values of a county, municipality, community, or other connected group to enable projects that balance safety while making needed improvements in a manner that fits the surroundings and provides overall benefit to the public.

### 1.B.3 Practical Design

Policy DES 22-03, January 2023, provides flexibility in the application of Nebraska's highway design standards, in accordance with a Memorandum of Understanding between **NDOT** and the **Board**, executed on October 26, 2022 (<https://dot.nebraska.gov/media/xwalmisw/ndot-program.pdf>). For additional information see Chapter Seventeen: Resurfacing, Restoration and Rehabilitation (3R) Projects, Section 1.H, of this manual and the **FHWA** web page "Performance-Based Practical Design" ([Performance-Based Practical Design - Design - Federal Highway Administration \(dot.gov\)](https://www.fhwa.dot.gov/performancebasedpracticaldesign/)).



### 1.B.4 3R Standards for Expressways with Access Only at Interchanges

In response to the January 3, 2022, amendments to 23 CFR 625 (see Section 1.A.1 of this chapter), and in accordance with a Memorandum of Understanding between **NDOT** and the **Board**, executed on August 22, 2023 (<https://dot.nebraska.gov/media/2nvi4ir2/ndot-practical-design2023-1.pdf>), Policy DES 23-02 will allow **NDOT** to use newly established 3R (Resurfacing, Restoration, and Rehabilitation) standards for projects on highway segments functionally classified as Expressway, but limited to such expressway segments that allow access only from interchanges (the national functional classification is Freeway). For additional information see Chapter Seventeen: Resurfacing, Restoration and Rehabilitation (3R) Projects, Section 1.F, of this manual

## 2. DESIGN STANDARDS

The primary sources of roadway design guidance and standards for **NDOT** are A Policy on Geometric Design of Highways and Streets (*Green Book*) (Ref. 1.1), A Policy on Design Standards Interstate System (*I-State Green Book*) (Ref. 1.2), the Nebraska Minimum Design Standards (*MDS*) (Ref. 1.3), and this manual. The *MDS* is in Chapter Two of the Nebraska Administrative Code, Title 428 (<https://dot.nebraska.gov/media/1z1n5kmb/nac-428-rules-regs-nbcs.pdf>). The Roadway Design Manual is based on research and publications from **NDOT**, the **American Association of State Highway and Transportation Officials (AASHTO)**, the **Federal Highway Administration (FHWA)**, the **Access Board**, and others.

## 3. HIGHWAY CLASSIFICATION

### 3.A Classification

Highway system classification is the grouping of highways by their purpose and function (See EXHIBITS 1.1 AND 1.2). Access and mobility are important factors in determining the classification of a highway. Access and mobility exist in an inverse relationship, the greater the access to the highway the lower the mobility. In the classification of highways the greater the mobility the higher the classification. The highest classification is the Interstate, which provides nationwide mobility but access only at interchanges. Local roads, on the other hand, may provide many direct access points but also provide a lower level of mobility.

The classification of a highway includes the highway's function in a network, context (rural/municipal), traffic volume, trip purposes, and length. Highway system classification is used for roadway identification, selecting the applicable design guidance, project prioritization, and funding purposes for planning, design, traffic operations, and administration of the highway program (minor collectors and local roads are not eligible for Federal-aid funds).

### 3.A.1 National Highway Functional Classification Map (Nebraska)

(<https://dot.nebraska.gov/travel/map-library/county/>)

(<https://dot.nebraska.gov/travel/map-library/city/>)

This map shows six classes of roadway:

1. Interstate
2. Other Freeways & Expressways
3. Other Principal Arterials
4. Minor Arterial
5. Major Collector
6. Minor Collector (not eligible for Federal-aid funds)

These classes are based on the **AASHTO** functional classes found and defined in the *Green Book* (Ref. 1.1), the *I-State Green Book* (Ref. 1.2), and in the **FHWA** publication Highway Functional Classification Concepts, Criteria and Procedures (Ref. 1.4, [https://www.fhwa.dot.gov/planning/processes/statewide/related/highway\\_functional\\_classification/fcauab.pdf](https://www.fhwa.dot.gov/planning/processes/statewide/related/highway_functional_classification/fcauab.pdf)).

### 3.A.2 State Highway Functional Classification Map (Nebraska)

(<https://dot.nebraska.gov/travel/map-library/county/>)

(<https://dot.nebraska.gov/travel/map-library/city/>)

This map shows the following eight roadway classifications:

1. Interstate
2. Expressway
3. Major Arterial
4. Other Arterial
5. Collector
6. Remote Residential (Rural Only)
7. Minimum Maintenance (Rural Only)
8. Scenic Recreation (Rural Only)

The state functional classification defines the characteristics for rural and municipal area roadways, as established in the Reissue Revised Statutes of Nebraska Laws Applicable to the Nebraska Department of Transportation (Containing Chapter 3, Aeronautics; Chapter 39, Highways and Bridges; Chapter 49, Laws, Article 8, Definitions, Construction, and Citation; Chapter 60, Motor Vehicles, Article 6, Nebraska Rules of the Road; and Chapter 81, Article 7, Department of Transportation) (<https://nebraskalegislature.gov/laws/browse-statutes.php>) (Ref. 1.5).

<b>RURAL HIGHWAY FUNCTIONAL CLASSIFICATIONS</b>	
<b>FEDERAL HIGHWAY ADMINISTRATION (FHWA) Source: Ref. 1.4</b>	<b>STATE OF NEBRASKA Source: Ref. 1.5</b>
* <b>NDOT</b> has responsibility for the design, construction, reconstruction, maintenance, and operation of the following rural highway classifications.	
<b>Principal Arterial - Interstate:</b> All routes that comprise the Dwight D. Eisenhower National System of Interstate and Defense Highways belong to the Interstate functional classification and are considered Principal Arterials.	<b>Interstate:</b> The federally designated National System of Interstate and Defense Highways.
<b>Principal Arterial - Other Freeways &amp; Expressways:</b> Roadways in this functional classification category look very similar to Interstates. While there can be regional differences in the use of the terms 'freeway' and 'expressway', for the purpose of functional classification the roads in this classification have directional travel lanes, are usually separated by some kind of physical barrier, and their access and egress points are limited to on- and off-ramp locations or a very limited number of at-grade intersections. Like Interstates, these roadways are designed and constructed to maximize their mobility function, and abutting land uses are not directly served by them.	<b>Freeway:</b> An expressway with full control of access and with grade separations at all intersecting road crossings.
	<b>Expressway:</b> A group of highways following major traffic desires in Nebraska which rank next in importance to the National system of Interstate and Defense Highways. The expressway system is one which ultimately should be developed to multilane divided highway standards.
<b>Other Principal Arterials:</b> These roadways serve major centers of metropolitan areas, provide a high degree of mobility and can also provide mobility through rural areas. Unlike their access-controlled counterparts, abutting land uses can be served directly. Forms of access for Other Principal Arterial roadways include driveways to specific parcels and at-grade intersections with other roadways.	<b>Major Arterial:</b> The balance of routes which serve major statewide interests for highway transportation. This system is characterized by high-speed, relatively long-distance travel patterns.
	<b>Scenic-Recreation:</b> Highways or roads located within or which provide access to or through state parks, recreation or wilderness areas, other areas of geographical, historical, geological, recreational, biological, or archeological significance, or areas of scenic beauty.
* The various counties shall have responsibility for the design, construction, reconstruction, maintenance, and operation of the following rural highway classifications.	
<b>Minor Arterial:</b> Minor Arterials provide service for trips of moderate length, serve geographic areas that are smaller than their higher Arterial counterparts and offer connectivity to the higher Arterial system. In rural settings, Minor Arterial should be identified and spaced at intervals consistent with population density, so that all developed areas are within a reasonable distance of a higher level Arterial. Additionally, Minor Arterials in rural areas are typically designed to provide relatively high overall travel speeds, with minimum interference to through movement.	<b>Other Arterial:</b> Highways of less importance as through-travel routes which would serve places of smaller population and smaller recreation areas not served by the higher systems.

\* Nebraska Revised Statutes, Chapter 39-2105

**Exhibit 1.1 Rural Highway Functional Classifications**

<b>RURAL HIGHWAY FUNCTIONAL CLASSIFICATIONS</b>	
<b>FEDERAL HIGHWAY ADMINISTRATION (FHWA) Source: Ref. 1.4</b>	<b>STATE OF NEBRASKA Source: Ref. 1.5</b>
* The various counties shall have responsibility for the design, construction, reconstruction, maintenance, and operation of the following rural highway classifications.	
<p><b>Major and Minor Collectors:</b> Collectors serve a critical role in the roadway network by gathering traffic from Local Roads and funneling them to the Arterial network. In the rural environment, Collectors generally serve primarily intra-county travel (rather than statewide) and constitute those routes on which (independent of traffic volume) predominant travel distances are shorter than on Arterial routes. Consequently, more moderate speeds may be posted. Generally, Major Collector routes are longer in length; have lower connecting driveway densities; have higher speed limits; are spaced at greater intervals; have higher annual average traffic volumes; and may have more travel lanes than their Minor Collector counterparts. In rural areas, AADT and spacing may be the most significant designation factors; since Major Collectors offer more mobility and Minor Collectors offer more access.</p>	<p><b>Collector:</b> A group of highways which pick up traffic from many local or land-service roads and carry it to community centers or to the arterial systems. They are the main school bus routes, mail routes, and farm-to-farm market routes.</p>
<p><b>Local Roads:</b> Local Roads are not intended for use in long distance travel, except at the origin or destination end of the trip, due to their provision of direct access to abutting land. As public roads, they should be accessible for public use throughout the year. Local roads are often classified by default. In other words, once all Arterial and Collector roadways have been identified, all remaining roadways are classified as Local Roads.</p>	<p><b>Local:</b> All remaining rural roads, except minimum maintenance roads and remote residential roads.</p>
	<p><b>Minimum Maintenance:</b> (a) Roads used occasionally by a limited number of people as alternative access roads for areas served primarily by local, collector, or arterial roads or (b) roads which are the principal access roads to agricultural lands for farm machinery and which are not used by passenger or commercial vehicles.</p> <p><b>Remote Residential:</b> Roads or segments of roads in remote areas of counties with (a) a population density of no more than five people per square mile or (b) an area of at least one thousand square miles, and which roads or segment of roads serve as primary access to no more than seven residences. For purposes of this subdivision, residence means a structure which serves as a primary residence for more than six months of a calendar year. Population shall be determined using data from the most recent federal decennial census.</p>

\* Nebraska Revised Statutes, Chapter 39-2105

**Exhibit 1.1 Rural Highway Functional Classifications (Continued)**

<b>MUNICIPAL HIGHWAY FUNCTIONAL CLASSIFICATIONS</b>	
<b>FEDERAL HIGHWAY ADMINISTRATION (FHWA) Source: Ref. 1.4</b>	<b>STATE OF NEBRASKA Source: Ref. 1.5</b>
* <b>NDOT</b> has responsibility for the design, construction, reconstruction, maintenance, and operation of the following municipal highway classifications.	
<b>Principal Arterial - Interstate:</b> All routes that comprise the Dwight D. Eisenhower National System of Interstate and Defense Highways belong to the Interstate functional classification and are considered Principal Arterials.	<b>Interstate:</b> The federally designated National System of Interstate and Defense Highways.
<b>Principal Arterial - Other Freeways &amp; Expressways:</b> Roadways in this functional classification category look very similar to Interstates. While there can be regional differences in the use of the terms 'freeway' and 'expressway', for the purpose of functional classification the roads in this classification have directional travel lanes, are usually separated by some kind of physical barrier, and their access and egress points are limited to on- and off-ramp locations or a very limited number of at-grade intersections. Like Interstates, these roadways are designed and constructed to maximize their mobility function, and abutting land uses are not directly served by them.	<b>Freeway:</b> An expressway with full control of access and with grade separations at all intersecting road crossings.
	<b>Expressway:</b> (a) Extensions of rural expressways and (b) some additional routes which serve very high volumes of local traffic within urban areas.
<b>Other Principal Arterials:</b> These roadways serve major centers of metropolitan areas, provide a high degree of mobility and can also provide mobility through rural areas. Unlike their access-controlled counterparts, abutting land uses can be served directly. Forms of access for Other Principal Arterial roadways include driveways to specific parcels and at-grade intersections with other roadways.	<b>Major Arterial:</b> Extensions of the rural major arterials which provide continuous service through municipalities for long-distance rural travel. They are the arterial streets used to transport products into and out of municipalities

\* Nebraska Revised Statutes, Chapter 39-2105

**Exhibit 1.2 Municipal Highway Functional Classifications**

<b>MUNICIPAL HIGHWAY FUNCTIONAL CLASSIFICATIONS</b>	
<b>FEDERAL HIGHWAY ADMINISTRATION (FHWA) Source: Ref. 1.4</b>	<b>STATE OF NEBRASKA Source: Ref. 1.5</b>
<p>* The various counties and local governments shall have responsibility for the design, construction, reconstruction, maintenance, and operation of the following municipal highway classifications.</p>	
<p><b>Minor Arterial:</b> Minor Arterials provide service for trips of moderate length, serve geographic areas that are smaller than their higher Arterial counterparts and offer connectivity to the higher Arterial system. In an urban context, they interconnect and augment the higher Arterial system, provide intra-community continuity and may carry local bus routes.</p>	<p><b>Other Arterial:</b> (a) Municipal extensions of rural other arterials and (b) arterial movements peculiar to a municipality's own complex, that is streets which interconnect major areas of activity within a municipality, such as shopping centers, the central business district, manufacturing center, and industrial parks.</p>
<p><b>Major and Minor Collectors:</b> Collectors serve a critical role in the roadway network by gathering traffic from Local Roads and funneling them to the Arterial network. Collectors serve both land access and traffic circulation in residential and commercial/industrial areas. Operating characteristics of Major Collectors differ from Minor Collectors in length (usually greater than three-quarters of a mile), higher speeds and more signalized intersections.</p>	<p><b>Collector:</b> A group of streets which collect traffic from residential streets and move it to smaller commercial centers or to higher arterial systems.</p>
<p><b>Local Roads:</b> Urban Local Roads provide direct access to adjacent land, provide access to higher roadways systems and carry no through traffic movements. As public roads, they should be accessible for public use throughout the year. Local roads are often classified by default. In other words, once all Arterial and Collector roadways have been identified, all remaining roadways are classified as Local Roads.</p>	<p><b>Local:</b> The balance of streets in each municipality, principally residential access service streets and local business streets. They are characterized by very short trip lengths, almost exclusively limited to vehicles desiring to go to or from an adjacent property.</p>

\* Nebraska Revised Statutes, Chapter 39-2105

**Exhibit 1.2 Municipal Highway Functional Classifications (Continued)**

#### 4. HIGHWAY SYSTEMS

Highways may be networked into a system based on their intended function. The same highway may be part of multiple systems, for example the Interstate is part of the National Highway System, the Strategic Highway Network, and the National Highway Freight Network.

##### 4.A Interstate System

(<https://www.fhwa.dot.gov/programadmin/interstate.cfm>)

The Dwight D. Eisenhower National System of Interstate and Defense Highways (Interstate System) is a national defense system of highways consisting of routes built to uniform geometric and construction standards. This system connects the principal metropolitan areas, cities, and industrial centers of the United States and, to the greatest extent possible, connects the border routes of continental importance with Canada and Mexico. A map showing the Interstate routes in Nebraska is available at ([https://dot.nebraska.gov/media/msqjmmqq/nat\\_hwy\\_sys.pdf](https://dot.nebraska.gov/media/msqjmmqq/nat_hwy_sys.pdf)).

##### 4.B National Highway System (NHS)

([https://www.fhwa.dot.gov/planning/national\\_highway\\_system/](https://www.fhwa.dot.gov/planning/national_highway_system/))

The AASHTO Transportation Glossary (2009) defines the NHS as “A system of highway routes and connections to transportation facilities consisting of the Interstate System, other urban and rural arterial routes, and other connector highways to major intermodal transportation facilities.” The NHS serves interstate and interregional travel and includes the Strategic Highway Network, meeting national defense requirements. A map showing the NHS routes in Nebraska is available at ([http://www.fhwa.dot.gov/planning/national\\_highway\\_system/nhs\\_maps/nebraska/](http://www.fhwa.dot.gov/planning/national_highway_system/nhs_maps/nebraska/)).

##### 4.C Strategic Highway Network (STRAHNET)

As defined by the U.S. Department of Defense, “STRAHNET is a system of public highways that are a key part of the deployment of the United States Armed Forces. It provides defense access, continuity, and emergency capabilities for movements of personnel and equipment in both peace time and war.” The National Highway System Designation Act of 1995 provided for the inclusion of STRAHNET and STRAHNET connectors into the NHS. Additional information and maps of the STRAHNET routes and connectors in Nebraska may be found at (<https://www.sddc.army.mil/sites/tea/functions/specialassistant/strahnet/forms/allitems.aspx>).

**4.D**      **National Highway Freight Network**  
(<https://ops.fhwa.dot.gov/freight/infrastructure/nfn/index.htm>)

In 2012, the Moving Ahead for Progress in the 21st Century Act (MAP-21) required the **United States Department of Transportation (USDOT)** to establish a National Freight Network to assist the states in directing resources towards improving the movement of freight on the nation's highways. This network consisted of:

- A primary freight network (PFN), designated by the Secretary of the **USDOT**
- Any portions of the Interstate System not designated as part of the PFN
- Critical rural freight corridors

In 2015, the Fixing America's Surface Transportation Act (FAST) established the National Highway Freight Program to improve the efficient movement of freight on the National Highway Freight Network. Section 1116 of the FAST Act provided for a new National Highway Freight Network (NHFN), replacing the National Freight Network established under MAP-21.

The NHFN includes the following subsystem of roadways:

- a. Primary Highway Freight System (PHFS) - This is a network of highways identified as the most critical highway portions of the U.S. freight transportation system. The initial designation of the PHFS is highway-only Primary Freight Network (PFN) created under MAP-21.
- b. Interstate Routes not on the PHFS - These highways consist of the remaining portion of Interstate roads not designated as part of the PHFS. These routes provide important continuity and access to freight transportation facilities.
- c. Critical Rural Freight Corridors (CRFC) - These are public roads not in an urbanized area which provide access and connection to the PHFS and the Interstate with other important ports, public transportation facilities, or other intermodal freight facilities.
- d. Critical Urban Freight Corridors (CUFC) - These are public roads in urbanized areas which provide access and connection to the PHFS and the Interstate with other ports, public transportation facilities, or other intermodal transportation facilities.

A map showing the NHFN in Nebraska is available at  
([https://ops.fhwa.dot.gov/freight/infrastructure/ismt/state\\_maps/states/nebraska.htm](https://ops.fhwa.dot.gov/freight/infrastructure/ismt/state_maps/states/nebraska.htm)).

For additional information see the **FHWA** Memorandum "National Highway Freight Program (NHFP), FAST Act Section 1116 Implementation Guidance"  
([https://ops.fhwa.dot.gov/freight/pol\\_plng\\_finance/policy/fastact/s1116nhfpguidance/](https://ops.fhwa.dot.gov/freight/pol_plng_finance/policy/fastact/s1116nhfpguidance/)).



#### **4.E Nebraska Expressway System**

(<https://dot.nebraska.gov/media/edshoshk/expressway-system-nebraska.pdf>)

State law authorized the development of the Nebraska Expressway System (Expressway System) in 1988 (Nebraska Revised Statutes, Chapter 39-1365). The Expressway System generally consists of multi-lane divided highways. Access to the expressway other than at public roads will be limited; interchanges may be built where an expressway intersects with high volume highways. The intent of the expressway system is to:

1. Connect urban centers of 15,000 population or greater to the Interstate System,
2. Add those routes which have an average daily traffic of 500 or more heavy commercial vehicles, and
3. Add additional segments as required for continuity.

The Expressway System is also shown on the State and National Functional Classification Maps (<https://dot.nebraska.gov/travel/map-library/func-by-county/>) (<https://dot.nebraska.gov/travel/map-library/func-by-city/>).

#### **4.F Nebraska Priority Commercial System**

The 1988 Department Needs Study initiated the creation of the Nebraska Priority Commercial System, providing a continuous network of routes designed to carry higher traffic volumes, especially larger volumes of commercial vehicles. The Nebraska Priority Commercial System consists of the non-Interstate National Highway System and the Nebraska Expressway System. This system directly serves the first class cities (5,001 – 100,000 population), and directly or indirectly serves the majority of the second class cities (800 - 5,000 population). For additional information, see Chapter Six: The Typical Roadway Cross-Section, Section 2.A.1, of this manual.

#### **4.G Nebraska 28 Foot Top System**

Highways in the Sandhills area, highways with  $\geq 1,000$  future ADT, and highways that link US-6, US-30, or US-34 to the Interstate should have a 28-foot pavement width, striped at 24 feet, and shoulders appropriate for design year traffic (See the *MDS*, Ref. 1.3 and Chapter Six: The Typical Roadway Cross-Section, Section 2.A.2, and EXHIBITS 6.4 AND 6.5 of this manual). The intent of the additional surfacing width is to lessen the probability of vehicles leaving the roadway and to reduce erosion problems.

#### **4.H Other Nebraska State Highways**

(<https://dot.nebraska.gov/media/pyph2n2c/current-state-highway-system.pdf>)

In addition to the previously mentioned highways, **NDOT** is responsible for the administration of the state highway system for the efficient movement of people and goods throughout the State of Nebraska.

## 5. CAPITAL IMPROVEMENT VS SYSTEM PRESERVATION

Capital improvements (New and Reconstructed projects, See Section 6.A) consist of major modification road projects that extend beyond the work permitted under 3R. These projects generally entail a correction of vertical or horizontal alignment, removal and replacement of the surfacing and base, increase in capacity, and/or construction on a new alignment.

System Preservation projects consist of focused improvements toward a specific asset that the project is intended to preserve. These projects consist of 3R projects (See Section 6.B) and Preventive Maintenance projects.

1. **NDOT** 3R projects preserve highway assets (i.e. pavement or bridges) by addressing deficiencies in the pavement structure and may address safety and operational issues, primarily within the existing roadway footprint.
2. Preventive Maintenance projects (See Section 6.C.2) maintain the existing roadway to its original condition, maintain a minimum condition of bridges, and maintain, and in some instances upgrade, roadside appurtenances such as guardrail. Some maintenance system preservation work is not contracted and subsequently is performed by state maintenance forces.

## 6. APPLICATION OF DESIGN CRITERIA

### 6.A New and Reconstructed Criteria

The primary focus of this manual is the design of New and Reconstructed projects. New and Reconstructed projects have an expected service life exceeding 20 years and generally consist of:

- Construction of a new road
- Relocating an existing route on new alignment
- Removal of the pavement structure and construction of a new base or the modification of the existing base, which will be designed to reconstruction standards
  - Modification of the base is defined as improving or strengthening the existing base through chemical (fly ash, lime, etc.) or mechanical (geofabric, geogrid, etc.) means and will require designing to reconstruction standards
- Building a new bridge or reconstructing an existing bridge
- Adding through lanes to the existing alignment

New and Reconstructed projects should be considered when:

- The crash history indicates the need for improvements that can significantly reduce the crash rate
- Meeting 3R standards will require that significant existing geometric deficiencies be corrected
- Significant grading is to be done which requires major right-of-way to be acquired and/or major utility relocations

The minimum design standards for New and Reconstructed projects on the NHS may be found in the *Green Book* (Ref. 1.1), the *I-State Green Book* (Ref. 1.2), and in Appendix H, “AASHTO Minimum Design Guidance” of this manual. Design standards for projects not on the NHS have been issued by the **Board of Public Roads Classifications and Standards** and may be found in the *MDS* (Ref. 1.3). Note: rural and suburban areas exhibiting urban characteristics may be designed to municipal design standards.

Practical design considerations may allow application of 3R standards to a segment (or segments) of the current New and Reconstructed project (e.g. reconstructing the pavement structure at the existing width without modification of the existing base).

## **6.B Resurfacing, Restoration and Rehabilitation (3R) Criteria**

3R projects are generally undertaken to preserve the highway assets, improve the reliability of the transportation system, maintain the mobility of the highway user, mitigate highway safety issues identified through crash history and operational issues identified through analysis. Generally, it is not the purpose of 3R projects to increase highway capacity. A 3R resurfacing strategy typically has an expected service life of up to 20 years.

Application of 3R design standards to a pavement resurfacing project is, for the most part, determined by the pavement recommendation.

1. Pavement recommendations that address deficiencies in the pavement structure and increase the structural capacity and extend the life of the facility by up to 20 years will usually be designed to 3R standards. Pavement recommendations that require pavement replacement and restoration of the base can be designed to 3R standards. Restoration of the base is defined as restoring the original condition of the base (subgrade preparation). A portion of the existing base may be removed to accommodate the required pavement thickness based on the pavement recommendation.
2. Pavement recommendations that require removal of the entire pavement structure and the construction of a new base or the modification of the existing base will be designed to New and Reconstructed standards. Modification of the base is defined as improving (addition of a drainage layer) or strengthening the existing base through chemical (fly ash, lime, etc.) or mechanical (geofabric, geogrid, etc.) means. However, practical design considerations may allow application of 3R standards to a segment (or segments) of the current New and Reconstructed project (e.g. reconstructing the pavement structure at the existing width without modification of the existing base).

3R design utilizes a cost/benefit paradigm, including such strategies such as Practical Design, 2+2 Projects, and Super 2 Roadways.

For **NDOT** 3R guidance, see Chapter Seventeen: Resurfacing, Restoration and Rehabilitation (3R) Projects of this manual and the *MDS* (Ref. 1.3). Note: rural and suburban areas exhibiting urban characteristics may be designed to 3R municipal design standards.

### 6.B.1 Bridge Rehabilitation (3R) Work

The **Bridge Division (Bridge)** supplies the bridge recommendation, which provides the scope of work on the structures for a project.

In general, the scope of work for bridge rehabilitation projects (3R) may include, but is not limited to:

- Partial or complete replacement of the existing deck, including or adding new bridge approaches on pile.
- Replacement and/or strengthening (Rehabilitation) of the superstructure
  - When bridge decks are replaced or rehabilitated with Federal financial participation, pedestrians or bicyclists generally must be accommodated (See 23 U.S.C. 217(e), [https://www.govregs.com/uscode/title23\\_chapter2\\_section217](https://www.govregs.com/uscode/title23_chapter2_section217)). Existing pedestrian/bicyclist access should be maintained.
- Repairs to the substructure
- Incidental widening associated with these activities

Bridge rehabilitation work is eligible for federal-aid funding. For additional information see the **Federal Highway Administration (FHWA)** publication Bridge Preservation Guide (Ref. 1.9) (<https://www.fhwa.dot.gov/bridge/preservation/guide/guide.pdf>) and Chapter Seventeen: Resurfacing, Restoration and Rehabilitation (3R) Projects, Section 10.B, of this manual.

### 6.C Maintenance Projects

#### 6.C.1 Routine Maintenance

Routine maintenance is work performed on a regular basis to maintain and preserve the condition of the highway at a satisfactory level of service. Examples of routine maintenance include but are not limited to:

- Mowing the roadside
- Snow removal
- Clearing of ditches and drainage structures
- Maintenance of pavement markings
- Crack filling
- Pothole patching
- Isolated overlays

**NDOT** employees generally perform routine maintenance, which is not ordinarily eligible for federal-aid funding.

### 6.C.1.a Routine Bridge Maintenance Activities

Routine bridge maintenance activities are performed on a regular basis in response to operational needs and do not generally extend the useful life of the structure. Examples of routine bridge maintenance activities include:

- Trash Removal
- Snow Removal
- Application of Deicers
- Asphalt Patching
- Repairing Accident Damage (Bridge, Appurtenances)
- Repairing Storm Damage

**NDOT** employees generally perform routine bridge maintenance, which is not ordinarily eligible for federal-aid funding. For additional information see the **FHWA** publication Bridge Preservation Guide (Ref. 1.9).

### 6.C.2 Preventive Maintenance

Preventive Maintenance projects are programmed for the restoration of the existing mainline roadway surfacing back to its' original condition without significantly increasing the structural capacity. Preventive Maintenance is typically applied to pavements in good condition which have significant service life remaining. The **Board of Public Roads Classifications and Standards** has issued maintenance standards applicable for each functional classification of roadway (Chapter 2, Section 003, of the *MDS*, Ref. 1.3). Building curb ramps and upgrading roadway appurtenances (such as guardrail) are allowed on Preventive Maintenance projects. Mailbox turnouts will not generally be surfaced on a Preventative Maintenance project. A Preventive Maintenance project has an expected service life of up to 12 years.

Application of Preventive Maintenance standards to a project is generally determined by the pavement recommendation. A grade raise of two inches or less of surfacing, or its equivalent (See below), is permissible. More than a two-inch grade raise will indicate the initial programming of a 3R project, pending further investigation.

**M&R** has determined that one inch of in place recycle is structurally equivalent to one-quarter inch of Hot Mix Asphalt, e.g. a pavement determination of two inches of in place recycle followed by a one and one-half inch overlay is equivalent to a two-inch grade raise. In place recycling strategies include Cement Stabilized Bituminous, Fly Ash Stabilized Bituminous, Hydrated Lime Slurry Stabilization, Cold in place recycle with foam, and Hot in place recycle.

### 6.C.2.a Bridge Preventive Maintenance Activities

Bridge preventive maintenance extends the useful life of a bridge by the application of cost-effective treatments to bridges in good or fair condition. Bridge preventive maintenance may be cyclical or condition-based in nature.

Cyclical bridge maintenance consists of recurring activities, scheduled to preserve the bridge elements and to delay their deterioration. Examples of cyclical bridge maintenance activities include:

- Bridge Cleaning (Deck, Superstructure, Substructure)
- Cleaning and Flushing the Drains
- Cleaning Joints
- Deck/Parapet/Rail Sealing and Crack Sealing
- Concrete Sealing

Condition-based bridge maintenance work is performed to improve the condition of known defects of bridge components. Examples of work allowed on a condition-based Preventive Maintenance Bridge project include:

#### **Deck:**

- Overlays (Polymer, Asphalt with waterproof membrane, Rigid overlays)
- Approach Slabs (Repairs, Replacement of existing approach slabs)
- Slab Turndowns (Eliminate end-of-floor joint and encase girder ends)
- Joints (Repair, Replace, Eliminate)
- Joint Seals (Replace)
- Drains (Repair, Replace)
- Electrochemical Extraction (ECE)/Cathodic Protection (CP)
- General Repairs (Deck repairs, Bridge Rail and Buttruss update and repairs)

#### **Superstructure:**

- Structural Steel Repair/Retrofit (Fracture critical details, Fatigue prone details)
- Painting (Zone coat girder ends, Complete re-painting of steel superstructure)
- Bearing Restoration (Cleaning, Lubrication, Resetting, Repair, Replacement, Passive zinc anodes)
- Concrete (Seal, Patch, Repair)
- Protective Coat (Concrete/Steel Elements)
- Fatigue Crack Mitigation (Pin-and-hanger replacement, Retrofit fracture critical members)
- Movable Bridge Machinery (Cleaning, Lubrication, Repair)
- General Repairs (End of girder repairs, Damaged elements)

#### **Substructure:**

- Concrete (Patch, Repair)
- Corrosion Protection & Mitigation (Passive zinc anodes, Electrochemical chloride extraction)
- Protective Coat (Concrete/Steel Elements)
- Painting (Spot, Zone, Complete re-painting of steel substructure)
- Pile Preservation (Repairs, Jackets w/epoxy grout, Concrete encasement, Painting of steel bearing piles, Cathodic protection)
- General Repairs (Abutment & piers, Damaged elements)

**Channel:**

- Scour Counter Measures (Installation, Repair)
- Channel Cleaning (Debris removal)

Cyclical and condition-based bridge preventive maintenance work is eligible for federal-aid funding. For additional information see the **FHWA** publication Bridge Preservation Guide (Ref. 1.9).

**Guardrail:**

On Preventive Maintenance Bridge projects, guardrail attached to the bridge rail will be reviewed for:

- Impacts to the guardrail (has the guardrail been hit) and condition of the guardrail
- NCHRP or MASH compliance
- A minimum height of 28 inches above the surfacing for the Bridge Approach Section (BAS)
- A minimum height of 26½ inches above the surfacing for the W-Beam guardrail, in accordance with the Roadside Design Guide (Ref. 1.7)

If necessary, the guardrail will be raised to meet the above listed minimum heights and used in place. If the guardrail is unable to meet the above listed minimum heights or does not meet NCHRP 350 standards, the installation will be reviewed for possible replacement and upgrade to MASH standards. If the guardrail is to be used in place, a decision document requiring **NDOT Roadway Design Unit Head (Unit Head)** approval will be placed in the document file.

**6.D Safety Improvement Projects**

[\(https://dot.nebraska.gov/business-center/lpa/projects/programs/hsip/\)](https://dot.nebraska.gov/business-center/lpa/projects/programs/hsip/)

Safety improvement projects are usually located at specific significant crash sites. Significant crash locations are identified and evaluated for cost effectiveness and the **Highway Safety Improvement Plan Implementation Team** addresses critical areas, with federal funds, on a case-by-case basis. The **NDOT District Engineer (DE)** may also request a study of individual locations. Safety improvement projects are designed with 10-year traffic forecasts. These projects may include such actions as:

- Changing intersection geometry
- Adding left turn lanes
- Minor radii improvements
- Sight distance improvements

Safety improvement projects are designated as either 3R or the appropriate New and Reconstructed standard. Cost sharing guidelines for safety improvement projects in municipal areas are outlined in NDOT Operating Instruction DOT-OI 60-11, "Municipal Cost Sharing" (Appendix B, "Selected NDOT Operating Instructions").

## 7. DESIGN CONTROLS

Once the functional classification of the roadway is known and the type of roadway improvement determined, several basic factors serve as design controls. These controls are determinants for other geometric design standards. See the *Green Book* (Ref. 1.1), the *I-State Green Book* (Ref. 1.2) and the *MDS* (Ref. 1.3) for additional information. Design controls for 3R projects are addressed in Chapter Seventeen: Resurfacing, Restoration and Rehabilitation (3R) Projects, Section 1.B, of this manual.

### 7.A Design Year Forecast Traffic

The design year forecast traffic data (ADT, DHV, % Heavy Trucks, etc.) is based on the life expectancy of the roadway surfacing. The design year for New and Reconstructed projects and for 3R projects is the year of initial construction plus 20 years. Maintenance projects do not require forecast traffic data.

The designer should contact the **Traffic Analysis Section** of the **Strategic Planning Division** for design year forecast traffic data.

### 7.B Design Speed

The desirable design speed for a New and Reconstructed project is five mph greater than the anticipated posted speed limit for the roadway, except for low-speed municipal projects ( $\leq 45$  mph) where the design speed should be the anticipated posted speed limit. The minimum design speed may be found in the *MDS* (Ref. 1.3). Where the design speed from the *MDS* is greater than the anticipated posted speed limit the design speed from the standards will be used. For example, if the design speed from the *MDS* is 60 mph and the anticipated posted speed limit of the roadway is 50 mph, a design speed of 60 mph will be used.

Reduction of the desirable design speed to the minimum design speed will require **NDOT Roadway Design Assistant Design Engineer (ADE)** approval. A design relaxation will be required to design to less than the design speed provided in the *MDS* (Ref. 1.3) (See Section 10.C of this chapter).

### 7.C Sight Distance

Sight distance includes stopping sight distance, passing sight distance, and intersection sight distance. For further discussion of sight distance see Chapter Four: Intersections, Driveways and Channelization, Section 1.C.2 of this manual and Chapter 3, Section 3.2 and Chapter 9, Section 9.5 of the *Green Book* (Ref. 1.1).

### 7.D Terrain

Terrain is a design control affecting alignment. Two types of terrain, defined in Chapter 3, Section 3.4.1 of the *Green Book* (Ref. 1.1), are found in Nebraska:

1. **Level:** Highway sight distances, as governed by both horizontal and vertical restrictions, are generally long or can be made to be so without construction difficulty or major expense.
2. **Rolling:** Natural slopes which consistently rise above and fall below the road or street grade, and occasional steep slopes offer some restriction to normal horizontal and vertical roadway alignment.



## 7.E Roadside Design

**Horizontal Clear Zone:** For New and Reconstructed projects, the Horizontal Clear Zone is the roadside area, starting at the edge of the travel lane, which is available for errant vehicles leaving the roadway. The Horizontal Clear Zone provides an area free of fixed obstacles and may consist of the shoulder, a recoverable slope, a non-recoverable but traversable slope, and/or a clear runout area. The required clear zone distance will vary based on the projects' design standard (See the *MDS*, Ref. 1.3). See Chapter Six: The Typical Roadway Cross-Section, Section 9.A.1, of this manual for additional information.

**Fixed Obstacle Clearance:** For 3R projects, the Fixed Obstacle Clearance, as presented in the *MDS* (Ref. 1.3), provides a roadside environment free of fixed obstacles, reducing the opportunity for off-road impacts. See Chapter Six: The Typical Roadway Cross-Section, Section 9.A.2, of this manual for additional information.

## 7.F Context (Rural/Municipal)

Separate design standards have been developed for rural and municipal (urban) areas. Rural highways consist of public highways and roads outside the limits of an incorporated municipality; municipal streets are public streets within the limits of an incorporated municipality. Typical cross-sections will differ depending upon rural/municipal location. Rural design standards reflect the higher design speeds and more flexible right-of-way opportunities possible in rural areas while municipal design standards are based on the lower design speeds, restricted rights-of-way, and higher traffic volumes common in urban areas. Rural locations exhibiting municipal characteristics may be designed to municipal standards.

**AASHTO** has found it advisable to expand the traditional rural/municipal definition to five contexts, based not only on location but also on development density, land uses, and building setbacks. The following definitions are from Chapter 1, Section 1.5 of the *Green Book* (Ref. 1.1).

1. **Rural Context:** "The rural context applies to roads in rural areas that are not within a developed community. These include areas with the lowest development density; few houses or structures; widely dispersed or no residential, commercial, and industrial land uses; and usually large building setbacks. The rural context may include undeveloped land, farms, outdoor recreation areas, or low densities of other types of development. Most roads in rural areas fit the rural context and should be designed in a manner similar to past design criteria for rural facilities."
2. **Rural Town Context:** "The rural town context applies to roads in rural areas located within developed communities. Rural towns generally have low development densities with diverse land uses, on-street parking, and sidewalks in some locations, and small building setbacks. Rural towns may include residential neighborhoods, schools, industrial facilities, and commercial main street business districts, each of which present differing design challenges and differing levels of pedestrian and bicycle activity. The rural town context recognizes that rural highways change character where they enter a small town, or other rural community, and that design should meet the needs of not only through travelers, but also the residents of the community. Speed expectations of through travelers change when they enter a rural town."

3. **Suburban Context:** “The suburban context applies to roads and streets, typically within the outlying portions of urban areas, with low to medium development density, mixed land uses (with single-family residences, some multi-family residential structures, and nonresidential development including mixed town centers, commercial corridors, big box commercial stores, light industrial development). Building setbacks are varied with mostly off-street parking. The suburban context generally has lower development densities and drivers have higher speed expectations than the urban and urban core contexts. Pedestrians and bicyclist flows are higher than in the rural context, but may not be as high as found in urban and urban core areas.”
4. **Urban Context:** “The urban context has high-density development, mixed land uses, and prominent destinations. On-street parking and sidewalks are generally more common than in the suburban context, and building setbacks are mixed. Urban locations often include multi-story and low- to medium-rise structures for residential, commercial, and educational uses. Many structures accommodate mixed uses: commercial, residential, and parking. The urban context includes light industrial, and sometimes heavy industrial, land use. The urban context also includes prominent destinations with specialized structures for entertainment, including athletic and social events, as well as conference centers. In small- and medium-sized communities, the central business district may be more an urban context than an urban core context. Driver speed expectations are generally lower and pedestrian and bicyclist flows higher than in suburban areas. The density of transit routes is generally greater in the urban context than the suburban context, including in-street rail transit in larger communities and transit terminals in small- and medium-sized communities.”
5. **Urban Core Context:** “The urban core context includes areas of the highest density, with mixed land uses within and among predominantly high-rise structures, and with small building setbacks. The urban core context is found predominantly in the central business districts and adjoining portions of major metropolitan areas. On-street parking is often more limited and time restricted than in the urban context. Substantial parking is in multi-level structures attached to or integrated with other structures. The area is accessible to automobiles, commercial delivery vehicles, and public transit. Sidewalks are present nearly continuously, with pedestrian plazas and multi-level pedestrian bridges connecting commercial and parking structures in some locations. Transit corridors, including bus and rail transit, are typically common and major transit terminals may be present. Some government services are available, while other commercial uses predominate, including financial and legal services. Structures may have multiple uses and setbacks are not as generous as in the surrounding urban area. Residences are often apartments or condominiums. Driver speed expectations are low and pedestrian and bicycle flows are high.”

**AASHTO** design guidance for these contexts may be found in Appendix H of this manual.

## **7.G**      **Access Control**

Access control improves operational efficiency by limiting the number and location of access points along the highway (access control points are interchanges, intersections, driveways and field entrances). This increases the efficient movement of through traffic and reduces the potential for roadway crashes by minimizing the number of conflict points located along the highway. For further information see Chapter Fifteen: Right-of-Way, Section 3, of this manual.

## 8. THE CONTROLLING DESIGN CRITERIA

Through research and practical experience, minimum guidance has been established for the geometric design elements of a roadway project. The minimum values for the design criteria are based on such parameters as design speed, roadway location, functional classification of the roadway, traffic volume, and the design vehicle. **FHWA** has adopted the *I-State Green Book* (Ref. 1.2) and the *Green Book* (Ref. 1.1) as their source of roadway design guidance.

**FHWA** has identified ten elements of roadway geometry for all Interstate, freeway, and high-speed roadway ( $\geq 50$  mph) projects and two design elements for low-speed roadway ( $\leq 45$  mph) projects as being of such importance that when the minimum design standard cannot be attained for a project on the NHS and/or for a **FHWA** Risk Based Project (RBP for Design), a design exception will be required (See Section 10.A of this chapter). This same rationale was used in the creation of the *MDS* (Ref. 1.3). If a design criterion on any highway project cannot meet the minimum design standard, a relaxation of the *MDS* will be required (See Section 10.B of this chapter). The **FHWA** standards are:

FHWA Controlling Design Elements for Interstate, Freeway, and High-Speed ( $\geq 50$ mph) Roadways		
	Element	Definition
1	<b>Design Speed</b>	The speed selected to control the geometric features of the project
2	<b>Lane Width</b>	The appropriate width to be used for the through travel lanes
3	<b>Shoulder Width</b>	The appropriate shoulder width for the roadway
4	<b>Horizontal Curve Radius</b>	The horizontal curvature of the roadway
5	<b>Superelevation Rate</b>	The appropriate cross slope of the roadway through a horizontal curve
6	<b>Maximum Grade</b>	The rate of change in the elevation of a roadway, expressed as a percentage
7	<b>Stopping Sight Distance</b>	The distance required by a driver to see an object on the roadway and to bring the vehicle to a safe stop before colliding with that object
8	<b>Cross Slope</b>	The cross slope aids in draining the roadway and shoulder
9	<b>Vertical Clearance</b>	The clear distance required between the top of the pavement and an overhead object across the entire width of the roadway
10	<b>Structural Capacity</b>	The load carrying capacity of a bridge or bridge sized structure

FHWA Controlling Design Elements for Low-Speed ( $\leq 45$ mph) Roadways		
	Element	Definition
1	<b>Design Speed</b>	The speed selected to control the geometric features of the project
2	<b>Structural Capacity</b>	The load carrying capacity of a bridge or bridge sized structure

NDOT has added four controlling design criteria to the *MDS*:

11	<b>Vertical Alignment</b>	The vertical curvature of the roadway
12	<b>Horizontal Clear Zone/Fixed Obstacle Clearance</b>	For New and Reconstructed projects, the Horizontal Clear Zone is the roadside area, starting at the edge of the travel lane, which is available for the recovery of errant vehicles. For 3R projects, the Fixed Obstacle Clearance provides an obstacle free zone in the roadside environment.
13	<b>Lateral Offset to Obstruction</b>	The distance from the edge of the traveled way to a vertical roadside object. Lateral offset to obstruction should not be confused with the Horizontal Clear Zone/Fixed Obstacle Clearance (See Section 8.B of this chapter)
14	<b>Bridge Width</b>	The width of the lanes and shoulders carried across the bridge, measured from bridge rail to bridge rail or curb to curb

These four additional items are not **FHWA** design criteria; inability to meet the minimum standard will not require a design exception but will require a relaxation of the *MDS* (See Section 10.B of this chapter).

***The 14 controlling design criteria in the MDS will apply to all roadway classifications (State and Federal) and all design speeds.***

#### **8.A NDOT Non-Controlling Design Criteria**

Four additional items have been determined by **NDOT** to be important to the design of a roadway while not rising to the level of a controlling criterion. These non-controlling items are:

1. **Barrier Crashworthiness:** Determine if the roadside barriers (e.g. guardrail, bridge rail) are compliant with MASH or NCHRP 350.
2. **Hydraulic Design:** Determine the appropriate **NDOT** Design Storm Frequency for the drainage system components (e.g. culverts, storm sewers, roadway ditches). See the Drainage Design and Erosion Control Manual, EXHIBIT 1.3, "Design Storm Frequencies".
3. **Pavement Design:** Determine if the projected life expectancy of the pavement is equal to or greater than the project design year.
4. **ADA Accessibility:** Determine if the project meets the guidance found in the Proposed Guidelines for Pedestrian Facilities in the Public Right-of-Way and if existing barriers to access will be eliminated. Any requirements which the **NDOT Roadway Design Engineer** determines to be technically infeasible shall be documented in the project file with the **NDOT Roadway Design Engineer's** signature. For additional information see Chapter Sixteen: Pedestrian and Bicycle Facilities of this manual.

An inability to meet the minimum guidance for these items will require written **Unit Head** approval and justification to the project file except as noted above.

## **8.B Nominal Shoulder Width for Lateral Offset to Obstruction**

### **8.B.1 Highways With an ADT < 400 VPD**

The lateral offset (nominal shoulder width) is given in EXHIBITS 1.3 AND 1.4. Roadside barriers may be placed at the outer edge of the shoulder; however, it is desirable to provide a minimum clearance of four feet from the edge of the traveled way to the barrier. No approval is necessary for the design decision.

### **8.B.2 Highways With an ADT $\geq$ 400 VPD**

The lateral offset (nominal shoulder width) is given in EXHIBITS 1.3 AND 1.4.

- On a paved or a turf only shoulder, the nominal shoulder width is the shoulder width. For example, on a New and Reconstructed Interstate project with high truck traffic, the shoulder widths are four foot left and 12 foot right, which is also the nominal shoulder width and the lateral offset to obstruction.
- On a shoulder with both a paved and a turf section, the nominal shoulder width is the total shoulder width. For example, on a New and Reconstructed Major Arterial project with an ADT between 2,000 and 3,999 the shoulder width is eight foot total with two foot paved. The nominal shoulder width and the lateral offset to obstruction is eight feet.

**NEW AND RECONSTRUCTED RURAL**

<b>State Functional Classification</b>	<b>National Functional Classification</b>	<b>Lateral Offset to Obstruction</b>
Interstate	Interstate	The paved shoulder width
Expressway (Access Only at Interchanges)	Other Freeways and Expressways	The paved shoulder width
Expressway	Other Freeways and Expressways	Left = 4 feet/Right = 8 feet
Major Arterial	Other Principal Arterials or Minor Arterial	ADT ≥ 1,000 VPD: 8 feet ADT 400 – 999 VPD: 6 feet ADT < 400 VPD: 4 feet
Major Arterial	Major Collector, Minor Collector or Local	ADT ≥ 2,000 VPD: 8 feet ADT 400 – 1,999 VPD: 6 feet ADT < 400 VPD: 4 feet
Scenic Recreation – Major Arterial	Other Principal Arterials, Minor Arterial, Major Collector or Minor Collector	Design Speed ≥ 50 mph: 6 feet Design Speed < 50 mph: 4 feet desirable 2 feet minimum

**NEW AND RECONSTRUCTED MUNICIPAL**

<b>State Functional Classification</b>	<b>National Functional Classification</b>	<b>Lateral Offset to Obstruction</b>
Interstate	Interstate	The paved shoulder width
Expressway (Access Only at Interchanges)	Other Freeways and Expressways	The paved shoulder width
Expressway	Other Freeways and Expressways	Curbed: 1.5 feet from the face of the curb Non-Curbed: Left = 4 feet Right = 8 feet
Major Arterial	Other Principal Arterials or Minor Arterial	Curbed: 1.5 feet from the face of the curb Non-Curbed: ADT ≥ 2,000 VPD: 8 feet ADT 400 – 1,999 VPD: 6 feet ADT < 400 VPD: 4 feet
Major Arterial	Major Collector or Minor Collector	Curbed: 1.5 feet from the face of the curb Non-Curbed: ADT ≥ 2,000 VPD: 8 feet ADT 400 – 1,999 VPD: 6 feet ADT < 400 VPD: 4 feet desirable 2 feet minimum

**Exhibit 1.3 Lateral Offset to Obstruction – New and Reconstructed Projects**

**RESURFACING, RESTORATION AND REHABILITATION (3R)**  
**RURAL**

<b>State Functional Classification</b>	<b>National Functional Classification</b>	<b>Lateral Offset to Obstruction</b>
Interstate	Interstate	The paved shoulder width
Expressway	Other Freeways and Expressways	The paved shoulder width
Major Arterial	Other Principal Arterials or Minor Arterial	ADT ≥ 2,000 VPD: 6 feet ADT < 2,000 VPD: 4 feet desirable 2 feet minimum
Major Arterial	Major Collector, Minor Collector or Local	ADT ≥ 2,000 VPD: 6 feet ADT < 2,000 VPD: 4 feet desirable 2 feet minimum
Scenic Recreation – Major Arterial	Other Principal Arterials, Minor Arterial, Major Collector or Minor Collector	4 feet desirable 2 feet minimum

**RESURFACING, RESTORATION AND REHABILITATION (3R)**  
**MUNICIPAL**

<b>State Functional Classification</b>	<b>National Functional Classification</b>	<b>Lateral Offset to Obstruction</b>
Interstate	Interstate	The paved shoulder width
Expressway	Other Freeways and Expressways	Curbed: 1.5 feet from the face of the curb Non-Curbed: 8 feet
Major Arterial	Other Principal Arterials or Minor Arterial	Curbed: 1.5 feet from the face of the curb Non-Curbed: ADT ≥ 4,000 VPD: 8 feet ADT 2,000 – 3,999 VPD: 5 feet ADT < 2,000 VPD: 4 feet desirable 2 feet minimum
Major Arterial	Major Collector or Minor Collector	Curbed: 1.5 feet from the face of the curb Non-Curbed: ADT ≥ 4,000 VPD: 8 feet ADT 2,000 – 3,999 VPD: 5 feet ADT < 2,000 VPD: 4 feet desirable 2 feet minimum

**Exhibit 1.4 Lateral Offset to Obstruction – Resurfacing, Restoration and Rehabilitation (3R) Projects**

## 8.C NDOT Desirable Design Guidance

NDOT has established preferred guidance for the following design criteria. This guidance will be used on all projects, where practicable.

- **Design Speed:** The desirable design speed for a New and Reconstructed project is five mph greater than the anticipated posted speed limit for the roadway, except for low-speed municipal projects ( $\leq 45$  mph) where the design speed should be the anticipated posted speed limit. (See Section 7.B of this chapter).
- **Design Speed – Left-in-Place Median Crossovers:** A desirable design speed of 65 mph (See Chapter Five: Interstates, Grade Separations, and Interchanges, Section 1.H.4, of this manual).
- **Design Speed – Interstate Phasing:** The design speed for phasing is 10 mph below the posted speed limit. (See Chapter Five: Interstates, Grade Separations, and Interchanges, Section 2.B, of this manual).
- **Design Speed – Temporary Roads:** As a rule-of-thumb, the design speed for the temporary road should be 10 mph less than the existing posted speed. (See Chapter Fourteen: Traffic, Section 6.B, of this manual).
- **Design Vehicle** - The use of a design vehicle smaller than the minimum listed in EXHIBIT 4.13 requires **Unit Head** approval. (See Chapter Four: Intersections, Driveways and Channelization, EXHIBIT 4.13, of this manual).
- **Intersection Turning Radius** - The minimum allowable distance between the edge of the full depth pavement and the outside edge of the tires of the turning design vehicle is two feet; the desirable distance is three feet. (See Chapter Four: Intersections, Driveways and Channelization, Section 1.C.6, of this manual).
- **Superelevation:** For rural highways and for bridge structures, a desirable maximum superelevation rate of 6% should be used unless design constraints dictate the use of the 8% maximum superelevation rate. The use of the maximum superelevation rate of 8% requires **ADE** approval and a decision letter to the project file. (See Chapter Three: Roadway Alignment, Section 2.C and EXHIBIT 3.2, of this manual).
- **Superelevation – Intersections on Curved Alignment:** The superelevation rate for state highways at intersection with other public roads is desirably 4% or less. (See Chapter Four: Intersections, Driveways and Channelization, Section 1.C.3.b, of this manual).
- **Turf Transition:** NDOT prefers that an additional two feet of turf transition be provided beyond the minimum shoulder width (See EXHIBITS 6.1 THROUGH 6.6). This will maintain the minimum shoulder width after a future overlay surfacing grade raise. If this transition cannot be provided, **ADE** approval and a decision document in the project file is required. (See Chapter Six: The Typical Roadway Cross-Section, Section 2.A, of this manual).
- **Minimum Grades for Drainage – Superelevation Runout:** To facilitate pavement drainage, a minimum profile grade of 1.5% shall be maintained through the area where the adverse crown has been removed. A flatter grade, down to and including a grade of 0.5%, may be used with **Unit Head** approval. (See Chapter Three: Roadway Alignment, Section 2.C.1, of this manual).



- **Minimum Grades for Drainage – Urban Curbed Roadways:** A minimum grade of 0.35% is acceptable. Flatter grades, down to and including 0.20% may be used with **Unit Head** approval. (See Chapter Three: Roadway Alignment, Section 3.A.2, of this manual).
- **Vertical Alignment and Stopping Sight Distance:** The desirable K values should be used for all New and Reconstructed projects. The desirable K values provide intersection stopping sight distance for passenger cars for various conditions. If the desirable K values cannot be met, the vertical curve may be designed to any length down to and including stopping sight distance with **Unit Head** approval and a decision letter to the project file. For intersection conditions other than listed in the exhibits, intersections and driveways (except for field entrances) will be evaluated for intersection sight distance according to the procedures presented in Chapter 9 of the *Green Book*, “Intersection Sight Distance”. (See Chapter Three: Roadway Alignment, Sections 3.B.2, 3.C, and 3.D and EXHIBITS 3.9 AND 3.14 of this manual).
- **Loop Ramps:** The **NDOT** desirable loop radius is 250 feet; the minimum loop radius is 100 feet. (See Chapter Five: Interstates, Grade Separations, and Interchanges, Section 3.B, of this manual).
- **Spiral Transition Curves:** Spiral transition curves are preferred on Interstate ramps due to the higher percentage of truck traffic. (See Chapter Five: Interstates, Grade Separations, and Interchanges, Section 3.C, of this manual).
- **Intersection Sight Distance:** Intersections on New and Reconstructed projects should be designed for intersection sight distance for left-turns from a minor roadway based on a passenger car (Section 9.5.3.2.1, “Case B1 – Left-Turn from the Minor Roadway” in Chapter 9 of the *Green Book*): **ADE** approval is required if this condition cannot be met. (See Chapter Four: Intersections, Driveways and Channelization, Section 1.C.2, of this manual).
- **Intersection Skew:** When designing New and Reconstructed projects, a skew of 15° or less is preferred. Use of a skew angle greater than 15° requires **Unit Head** approval, with input from **Traffic Engineering**. Method A is used when there are excessive impacts on one side of the roadway, Method B is the preferred intersection realignment; Methods C and D should only be used under very low volume conditions or, if in urban areas, where a minimum distance is provided between the offset intersections. The final design of the realignment requires **Unit Head** approval. (See Chapter Four: Intersections, Driveways and Channelization, Section 1.C.3 and EXHIBIT 4.12 of this manual).
- **Offset Right-Turn Lanes:** **NDOT** prefers the use of the tapered offset right-turn lane. **ADE** approval is required to design a parallel offset right-turn lane. (See Chapter Four: Intersections, Driveways and Channelization, Section 1.D.3 and EXHIBIT 4.16 of this manual).
- **Grading:** Variations from the typical grading section will require the approval of the **ADE** and the reasons for the variation will be documented in the project file. (See Chapter Six: The Typical Roadway Cross-Section, Section 9.B and EXHIBITS 6.8, 6.9, 6.10 and 6.16 of this manual).
- **Vertical Clearance:** For new structures it is desirable to include a six-inch allowance for future resurfacing. (See Chapter Ten: Miscellaneous Design Issues, Section 2.E.1, of this manual).

## 9. NDOT FORM 76

NDOT Form 76, “Roadway Design – Principal Controlling Design Criteria”, shall be filled-out for every New, Reconstructed, or 3R project. The completed NDOT Form 76 is circulated with the Plan-In-Hand Report and placed in the project file. The purpose of NDOT Form 76 is to highlight any design criteria used on the project which are less than the **AASHTO** minimum guidance (See Appendix H of this manual) and/or the guidance in the *MDS* (Ref. 1.3). Such criteria will require a design exception and/or a relaxation of the *MDS* (See Section 10 of this chapter).

### 9.A Instructions For Completing NDOT Form 76

#### 9.A.1 Sources

1. **Design Guidance from the *MDS***. The designer should use the *MDS* (Ref. 1.3) to obtain the minimum design values for all projects.
2. **AASHTO Minimum Design Guidance** (See Appendix H of this manual). This guidance has been consolidated from the *I-State Green Book* (Ref. 1.2), the *Green Book* (Ref. 1.1), and the Roadside Design Guide (Ref. 1.7). Some items in Appendix H may be less restrictive than the guidance found in the *MDS*, the designer may use the **AASHTO** design guidance for these items to avoid requesting a design exception and as a justification for using a lower design value when requesting a relaxation of the *MDS*.
3. **NDOT Desirable Design Guidance** (See Section 8.C of this chapter). This listing gives the **NDOT** preferred guidance from the Nebraska Roadway Design Manual and from Roadway Design Division Policy Letters. These design values will be used on all projects, where practicable.

#### 9.A.2 Instructions

NDOT Form 76 (See EXHIBIT 1.5) will be completed using the same format for all projects regardless of the level of approval authority.

Prior to filling out NDOT Form 76, the designer must determine whether the project is on the NHS and/or if it is a RBP for Design. The designer may view maps showing the NHS routes in Nebraska at [https://www.fhwa.dot.gov/planning/national\\_highway\\_system/nhs\\_maps/nebraska/](https://www.fhwa.dot.gov/planning/national_highway_system/nhs_maps/nebraska/). The designer should check Clarity® to determine if a project is a RBP for Design.

The designer, using the planning document as a guide and in consultation with the **Unit Head**, will determine the design values to be used on a project for each of the controlling design criteria (See Section 8 of this chapter). Placing a design value which is less than the minimum design value in NDOT Form 76 will require written **Unit Head** approval and justification to the project file. The applicable minimum design value will be entered in NDOT Form 76, in parenthesis, after the chosen design value. This will highlight any departure from the minimum design guidance requiring a design exception and/or a relaxation of the *MDS* (See Section 10 of this chapter).

**Projects on the NHS:** The designer may use the **AASHTO** minimum design values (See Appendix H of this manual) but should use the design values from the *MDS* (Ref. 1.3) as the minimum condition. By exceeding or meeting the *MDS* values it will not be necessary to request either a design exception or a relaxation of the *MDS*.

**Projects not on the NHS:** The designer will use the design guidance from the *MDS* (Ref. 1.3) as the minimum condition. If the minimum design values cannot be attained, the designer will need to request a relaxation of the *MDS* (See Section 10.B of this chapter). RBPs for Design not on the NHS which fail to meet the minimum design values will require a design exception (See Section 10.A.2 of this chapter) in addition to a relaxation of the *MDS*.

Note: When entering the appropriate minimum values into NDOT Form 76, give the source of the guidance (See EXHIBIT 1.5). The designer will enter the following abbreviations on the form:

- “Minimum Design Standards” = (MDS)
- “AASHTO Minimum Design Guidance” = (GB)
- A Policy on Design Standards – Interstate System = (I-State)
- Roadside Design Guide = (RDG)

Expressway 3R Standards are currently found in Chapter Seventeen: Resurfacing, Restoration and Rehabilitation (3R) Projects, Section 1.E. The designer will use the (MDS) abbreviation on the NDOT Form 76.

For Interstate 3R projects, when using the **AASHTO** standards in effect at the time of the most recent New and Reconstructed project on the section of the Interstate, the following abbreviation will be used, including the year the standards were published:

- Interstate = (I-State, [year])

**All projects:** If the designer cannot meet the *MDS* value for a design criterion, the **AASHTO** design guidance in Appendix H of this manual should be reviewed to see if that value may be used. The designer may use the **AASHTO** design guidance to avoid requesting a design exception and as a justification for using a lower design value when requesting a relaxation of the *MDS*.

When choosing the design values to be used on a project, the designer and **Unit Head** should refer to the “NDOT Desirable Design Guidance” (See Section 8.C of this chapter), the Roadway Design Manual, and the “Roadway Design Division Policy Letters” for additional guidance. Deviation from these guidelines will require approval from the appropriate **Roadway Design Division** level of authority.

**Roadway Design - Principal Controlling Design Criteria <sup>(1)</sup>**

Project No: 77-3 (120)		Control No.: 12345	Name: Blue Springs North
Designer: FJB		Unit Head: KC	
	<b>Roadway #1</b>	<b>Roadway #2</b>	
Highway or Local Road/Street <sup>(2)</sup> <i>Sta. to Sta. (RP to RP)</i>	U.S. 77 100+00 – 460+62 (13+34 – 20+17)	U.S. 77 625+88 – 982+28 (23+30 – 30+05)	
On National Highway System?	Yes	Yes	
FHWA RBP for Design? <sup>(3)</sup>	No	Yes	
State Functional Classification	Major Arterial	Expressway	
National Functional Classification	Arterial	Principal Arterial: Other Freeways & Expressways	
On Priority Commercial System? <sup>(4)</sup>	Yes	Yes	
ADT (Current/ Design Year) (VPD)	12,000	32,000	
Number of Lanes	2 Lane	4 Lane Divided	
Project Type (New & Reconstructed/ 3R)	New & Reconstructed	New & Reconstructed	
Location (Rural/ Municipal)	Rural	Rural	
<b>CRITERIA</b>	<b>DESIGN VALUE USED (MIN. DESIGN VALUE)</b>	<b>DESIGN VALUE USED (MIN. DESIGN VALUE)</b>	
Design Speed (mph)	65 mph (50 mph, MDS)	70 mph (55 mph, MDS)	
Lane Width (ft.)	12 ft. (12 ft., MDS)	12 ft. (12 ft., MDS)	
Shoulder Width (Total/Surf.-Rt./Lt.) (ft.)	8 ft. Paved Both Sides (8 ft. Paved Both Sides, MDS)	8 ft. Paved Right/ 4 ft. Paved Left (8 ft. Paved Right/ 4 ft. Paved Lt., MDS)	
<b>Horizontal Alignment</b>			
Superelevation (Maximum e) (%)	6% max. (8% max., MDS)	6% max. (8% max., MDS)	
Minimum Curve Radius (ft.)	1,660 ft. (758 ft., MDS)	2,040 ft. (960 ft., MDS)	
<b>Vertical Alignment</b>			
Crest K Value (Minimum)	327 (84, MDS)	289 (114, MDS)	
Sag K Value (Minimum)	211 (96, MDS)	197 (115, MDS)	
Maximum Grade (%)	3% Level, 4% Rolling (4% Level, 5% Rolling, MDS)	3% Level, 4% Rollin (4% Level, 5% Rolling, MDS)	
Stopping Sight Distance (Min.) (ft.)	840 ft. (425 ft., MDS)	790 ft. (495 ft., MDS)	
<b>Cross Slope (%)</b>			
Lane	2% (1.5% to 2%, MDS)	2% (1.5% to 2%, MDS)	
Shoulder	4% (2% to 6%, MDS)	4% (2% to 6%, MDS)	
Horizontal Clear Zone or Fixed Obstacle Clearance (ft.)	30 ft. (30 FT., MDS)	30 ft. (30 ft., MDS)	
Lateral Offset to Obstruction (ft.)	8 ft. (The Nominal Shoulder Width, MDS)	8 ft. Right/ 4 ft. Left (The Nominal Shoulder Width, MDS)	
<b>Vertical Clearance (ft.)</b>			
Structures	16.5 ft. (16 ft., MDS)	16.5 ft. (16 ft., MDS)	
Sign Trusses and Pedestrian/ Bicycle Overpasses	17.5 ft. (Structure Clearance + 1 ft., MDS)	17.5 ft. (Structure Clearance + 1 ft., MDS)	
Clear Bridge Width (Face of Rail to Face of Rail) (New & Reconstructed/ 3R) (ft.)	40 ft. (44 ft. MDS/ Full width of approach Roadway including paved shoulders and Pedestrian/ bicycle facilities = 40 ft., GB)	44 ft. (40 ft., MDS)	
Structural Capacity (Bridge Design Loading)	HL 93 (HL 93, MDS)	HL 93 (HL 93, MDS)	

(1) For additional information, see the Roadway Design Manual, Chapter One: Roadway Design Standards, Section 8.  
<http://dot.nebraska.gov/business-center/design-consultant/rd-manuals/>

(2) "Highway or Local Road/Street" is project-specific, roads may be listed individually or grouped together (e.g. mainline, ramps, county roads, arterials) if they have common design criteria.

(3) Risk Based Project. See the Roadway Design Manual, Chapter One: Roadway Design Standards, Section 10.

(4) For additional information, see the Roadway Design Manual, Chapter Six: The Typical Roadway Cross-Section, Section 2.A.1

MDS = Minimum Design Standards  
 GB = "AASHTO Minimum Design Guidance"  
 RDG = Roadside Design Guide

THIS PROJECT WILL REQUIRE A DESIGN EXCEPTION YES  NO

THIS PROJECT WILL REQUIRE A RELAXATION OF THE MINIMUM DESIGN STANDARDS YES  NO

Non-Controlling Design Criteria <sup>(5)</sup>		
	Roadway #1	Roadway #2
<b>Barrier Crashworthiness</b> <i>(MASH or NCHRP 350 Compatible?)</i>	Yes	Yes
<b>Hydraulic Design</b> <i>(Drainage Manual, pg. 1-12)</i>		
<b>Culvert</b> <i>(Design Storm)</i>	50 yr.	50 yr.
<b>Storm Sewer</b> <i>(Design Storm)</i>	50 yr.	50 yr.
<b>Pavement Design</b> <i>(Pvmt Design Life/Proj Design Year)</i>	20 yr./ 2042	20 yr./ 2042
<b>ADA Accessibility</b> Will existing barriers to pedestrian accessibility be eliminated as part of this project?  Does this project conform to the NDOT ADA design guidance as presented in Chapter Sixteen of the RDM and in NDOT Operating Instruction 60-10?	Yes <input type="checkbox"/> No <input checked="" type="checkbox"/>  Yes <input checked="" type="checkbox"/> No <input type="checkbox"/>	Yes <input type="checkbox"/> No <input checked="" type="checkbox"/>  Yes <input checked="" type="checkbox"/> No <input type="checkbox"/>

(5) For additional information, see the [Roadway Design Manual](#), Chapter One: [Roadway Design Standards](#), Section 8.

**Notes:**

Roadway #1:

A Relaxation of the [Minimum Design Standards](#) will be required for the bridge width at Station 145+20. A 40 ft. bridge width does satisfy the AASHTO Green Book value for a Rural Arterial ([Roadway Design Manual](#), Appendix H, page H-9) so a Design Exception from the FHWA will not be required.

Approved by: \_\_\_\_\_ / \_\_\_\_\_  
 Asst. Rdwy. Design Engineer Date

Approved by: \_\_\_\_\_ / \_\_\_\_\_  
 Roadway Design Engineer Date

Approved by: \_\_\_\_\_ / \_\_\_\_\_  
 District Engineer Date

Reviewed by: \_\_\_\_\_ / \_\_\_\_\_  
 FHWA (If Risk Based Project) Date

NDOT Form DR-76, March 2023

**Exhibit 1.5 Example NDOT Form 76**

## 10. DEPARTURE FROM STANDARDS

The **AASHTO** minimum design guidance is presented in the *I-State Green Book* (Ref. 1.2), the *Green Book* (Ref. 1.1), and the Roadside Design Guide (Ref. 1.7). This guidance is consolidated in Appendix H of this manual. If the **AASHTO** minimum design guidance cannot be attained for one or more of the controlling design criteria for a project on the NHS, a design exception will be required. A design exception will also be required if the design guidance in the *MDS* (Ref. 1.3) cannot be attained for one or more of the controlling design criteria for a **FHWA** Risk Based Project (RBP for Design) which is not on the NHS. Documentation for the design exception will be included in the project file, as detailed in Section 10.A.2 of this chapter.

If the design standards in the *MDS* (Ref. 1.3) cannot be attained for one or more of the controlling design criteria for any project, a relaxation of the *MDS* will be required, as detailed in Section 10.B of this chapter, unless the project is classified as a Maintenance project. Documentation for the design relaxation will be included in the project file.

### 10.A Design Exceptions for Projects on the NHS and for Risk Based Projects

#### 10.A.1 Oversight Authority for Departure from Standards

**FHWA PROJECT APPROVAL AUTHORITY:** **FHWA** retains full oversight and approval authority for design exceptions to the controlling design criteria for any project on the NHS which has been designated as a RBP for Design.

The designer should check Clarity<sup>®</sup> to determine if a project is a RBP for Design.

**NDOT PROJECT APPROVAL AUTHORITY:** Under the terms of the NDOT/FHWA Stewardship & Oversight Agreement (<https://dot.nebraska.gov/business-center/fhwa/>), **NDOT** assumes oversight and approval authority for design exceptions to the controlling design criteria for any project on the NHS which is not designated as a RBP for Design and for any project designated as a RBP for Design which is not on the NHS.

#### 10.A.2 Design Exception Documentation for RBPs for Design

**RBPs for Design which are on the NHS:** For RBPs for Design on the NHS that do not meet the **AASHTO** minimum design guidance (See Appendix H of this manual), a design exception document (See EXHIBIT 1.6) will be prepared for **FHWA** approval (See “Guidance on NHS Design Standards and Design Exceptions”, <https://www.fhwa.dot.gov/design/standards/ga.cfm>). If the project does not meet the design standards found in the *MDS* (Ref. 1.3), the designer will also request a relaxation of the *MDS*, as detailed in Section 10.B of this chapter, before obtaining **FHWA** approval.

**RBPs for Design which are not on the NHS:** For RBPs for Design which are not on the NHS and do not meet the guidance found in the *MDS* (Ref. 1.3), a request for relaxation of the *MDS* will be prepared, as detailed in Section 10.B of this chapter, for both the project file and for approval by the **NDOT Deputy Director - Engineering**. This documentation does not require **FHWA** approval but will be transmitted to the appropriate **FHWA Transportation Engineer**.

**Projects on the NHS which are not RBPs for Design:** For projects on the NHS that do not meet the **AASHTO** minimum design guidance (See Appendix H of this manual), a design exception document will be prepared for both the project file and for approval by the **NDOT Deputy Director - Engineering**. This documentation will not be submitted to the **FHWA** for approval but will be transmitted to the appropriate **FHWA Transportation Engineer**. The designer will also request a relaxation of the *MDS* as detailed in Section 10.B of this chapter.

**Projects meeting the minimum standards:** The Plan-in-Hand Report will note those projects that meet the minimum design standards.

## **10.B      Design Relaxations of the *MDS***

A request for a design relaxation letter will follow the **FHWA** memo “Guidance on NHS Design Standards and Design Exceptions” (<https://www.fhwa.dot.gov/design/standards/qa.cfm>) and will contain the following information:

- Specific design criteria that will not be met
- Existing roadway characteristics
- Alternatives considered
- Comparison of the safety and operational performance of the roadway and other impacts such as right-of-way, community, environmental, cost, and usability by all modes of transportation
- Proposed mitigation measures
- Compatibility with adjacent sections of roadway

“Design Speed” and “Design Loading Structural Capacity” are fundamental criteria in the design of a project and additional documentation is required for relaxations of these criteria. “Design Speed” relaxations should describe the length of the proposed section with a lower design speed compared to the overall length of the project and the measures that will be used in transitioning to adjacent sections with a different design speed. Documentation for relaxations of the “Design Loading Structural Capacity” should include verification of safe load-carrying capacity (load rating) for all State unrestricted legal loads or routine permit loads and, in the case of bridges and tunnels on the Interstate System, all Federal legal loads.

The request for relaxation of the *MDS* will be routed through the **NDOT Division Head** and will then be transmitted to the **NDOT Deputy Director-Engineering** for approval. After approval, the request will be sent to the **Secretary of the Board of Public Roads Classifications and Standards** at least ten working days prior to the board meeting at which it will be presented to the **Board of Public Roads Classifications and Standards** for their approval.

The request for a relaxation of the *MDS* will be presented to the **Board of Public Roads Classifications and Standards** in a power point format. The power point presentation will include location maps, aerial views and pictures of the location(s) of the relaxation, typical sections (existing, proposed, and standard), slides concerning crashes (not including protected information), costs to obtain standards, environmental impacts, etc. The designer or the **Unit Head** will schedule a meeting at least two weeks in advance of the board meeting to present the power point to the **NDOT Roadway Design Engineer**.

### **10.C      Procedure for When Desirable Conditions Cannot be Attained**

In those instances where it is not possible to meet the desirable design condition (See Section 8.C of this chapter), a decision document will be created (See EXHIBIT 1.7). The Design Decision Documentation Sheet, NDOT Form 335, may be used for this purpose. This document should be coordinated with the appropriate **NDOT Divisions** (e.g. **DE, Project Development, Traffic Engineering**) and by the appropriate level of supervision (such as the **Unit Head** or the **ADE**) and placed in the project file. For example: where it is not possible to design a temporary roadway to a design speed 10 mph less than the existing posted speed limit, the designer will detail the reasons why a lower design speed is necessary, obtain approval from the **Unit Head**, and coordinate with **Traffic Engineering**.





Pete Ricketts, Governor

December 1, 2017

Mr. Joseph Werning  
Nebraska Federal Highway Administration  
100 Centennial Mall Room 220  
Lincoln, NE 68509-3803

Re: Project No. S-680-9(35)  
C.N. 22632  
Mormon Bridges  
Design Exception Request

Dear Mr. Werning

Pursuant to the Code of Federal Regulations (CFR) 625.3(f), exceptions may be approved on a project basis for designs that do not conform to the minimum or limiting criteria set forth in the standards, policies, and standard specifications adopted in 23 CFR 625. FHWA identified 10 Controlling Criteria as having substantial importance to the operational and safety performance of any highway. The Nebraska Department of Transportation (NDOT) is requesting an exception for two of these criteria, shoulder width and vertical clearance. NDOT is requesting the existing one foot inside and outside shoulder width and 15.69 foot vertical clearance for the I-680 eastbound bridge over the Missouri River at reference post (RP) 13.43 to remain in place.

NDOT is developing plans to make 3R improvements to the Mormon Bridges on I-680 over the Missouri River at Reference Post 13.43 between Douglas County, Nebraska and Pottawattamie County, Iowa. The Nebraska Board of Public Roads Classifications and Standards approved the relaxation of standards on October 20, 2017 (see attached request letter and approval letter).

NDOT will engage in mitigation strategies to address the shoulder width and vertical clearance design exception of the eastbound structure. These strategies include providing a "Low Clearance" sign in advance of the structure and a "Bridge Clearance 15'-6"" sign at the first eastbound truss. The bridge width will be mitigated with delineators and object markers on the guardrail approaches to the eastbound bridge.

After evaluation, NDOT staff has concluded it is in the public's interest to make 3R improvements to the existing I-680 eastbound Mormon Bridge. We request FHWA to approve this exception to the Minimum Design Standards for Shoulder Width and Vertical Clearance.

Sincerely,

Mike Owen, P.E.,  
Roadway Design Engineer

Attachment: Location Map

Request letter to Nebraska Board of Public Roads Classifications and Standards  
Excerpt from 10/20/17 Nebraska Board of Public Roads Classifications and Standards

FHWA Concurrence \_\_\_\_\_

Date \_\_\_\_\_

Department of Transportation

1500 Highway 2  
PO Box 94759  
Lincoln, NE 68509-4759

OFFICE 402-471-4567 FAX 402-479-4325  
NDOT.ContactUs@nebraska.gov

dot.nebraska.gov

### Design Decision Documentation Sheet

Project No.: <p style="text-align: center;">S-80-9(1215)</p>	Control No.: <p style="text-align: center;">22646</p>	Date: <p style="text-align: center;">2/2/2018</p>
Project Name/Location: <p style="text-align: center;">I-480 - 24<sup>th</sup> Street, Omaha</p>		
Designer: <p style="text-align: center;">Brian Johnson</p>		
Item/Subject: <p style="text-align: center;">WB I-80 Retaining Wall at MM 453.2</p>		
<p><b>Identify Design Guideline/Desirable Condition:</b></p> <p>As per the Board of Public Roads Classifications and Standards, New and Reconstructed Municipal Interstate, the shoulder width with truck traffic exceeding 250 DHV are to be 12 feet paved.</p> <p>A relaxation was granted by the Board of Public Roads on September 16, 2016 for a design which reduces the shoulders of I-80 in 5 locations so as to allow the four lane section to become six lanes. In particular, the westbound outside shoulders under the 24<sup>th</sup> Street Bridge would be restricted by the existing bridge piers to a width of 8.8 feet for 380 linear feet, then tapers out to 12 feet wide for another 750 linear feet before tapering in to a shoulder width of 6.2 foot at the WB 24<sup>th</sup> Street on-ramp bridge barrier for 300 linear feet.</p> <p>To provide the approved shoulder tapering, an existing WB concrete barrier on the outside shoulder will be removed, pavement widened by 4 feet and the concrete barrier reconstructed.</p>		
<p><b>Reason Design Guideline/Desirable Condition Will Not be Met: (Cost, ROW, etc.)</b></p> <p>A survey of WB I-80 did not include an existing 200 foot long retaining wall along the outside shoulder prior to the 24<sup>th</sup> Street on-ramp nor was a wall designed at that location to be support the widened pavement. Bridge Division proposed designing a steel sheet pile wall with concrete coping to support the pavement widening with granular material to fill the void with the existing retaining wall. The steel sheet pile wall is estimated at \$300,000.</p>		
<p><b>Design Solution Used and Why:</b></p> <p>The outside shoulder for westbound I-80 can remain as is and will provide a consistent 8.8 foot shoulder until reaching the 6.2 foot shoulder as the 24<sup>th</sup> Street on-ramp enters I-80. Although the widening of the concrete barrier provide a 12 foot shoulder for 750 feet is desirable, the tapering of the barrier after the 24<sup>th</sup> Street Bridge piers (within a tangent section) and at the 24<sup>th</sup> Street on-ramp (which occurs at the beginning of a curve) would potentially be confusing to a driver's perception.</p> <p>A comparison of the 12 foot shoulder versus the 8.8 foot shoulder using Interchange Safety Analysis Tool, enhanced, or ISATe, produced a distribution of crashes that there would be effectively no change. The attached ISATe document shows the expected distribution of crashes for three alternatives:</p> <ol style="list-style-type: none"> <li>1- Top table is a four lane roadway using the existing geometrics</li> <li>2- Middle table is a six lane roadway with all shoulder restrictions used in the relaxation, except that the WB outside shoulder was assumed to be a constant 6 foot width in this area for the ease of creating the spreadsheet. Adding the concrete barrier tapers would have been extensive.</li> <li>3- The bottom graph is a six lane roadway with the extensive sectioning of the roadway to create the 12 foot shoulders with tapers.</li> </ol>		
<p><b>Review/Comment by Others: (District, Traffic, M&amp;R, Wetlands, etc.)</b></p>   		

**Attached Documentation:** (*Photograph, Email, etc.*) none

Approval: \_\_\_\_\_ OR Approval Document Attached  
(Name) (Print Name)

## 11. REFERENCES

- 1.1 American Association of State Highway and Transportation Officials, A Policy on Geometric Design of Highways and Streets (*Green Book*), Washington, D.C., 2018.
- 1.2 American Association of State Highway and Transportation Officials, A Policy on Design Standards Interstate System (*I-State Green Book*), Washington, D.C., 2016.
- 1.3 Board of Public Roads Classifications and Standards, Nebraska Minimum Design Standards (*MDS*), Current Edition.  
(<https://dot.nebraska.gov/media/1z1n5kmb/nac-428-rules-regs-nbcs.pdf>)
- 1.4 Federal Highway Administration, Highway Functional Classification Concepts, Criteria and Procedures, U.S. Department of Transportation, FHWA, Washington, D.C., 2013.  
([https://www.fhwa.dot.gov/planning/processes/statewide/related/highway\\_functional\\_classifications/fcauab.pdf](https://www.fhwa.dot.gov/planning/processes/statewide/related/highway_functional_classifications/fcauab.pdf))
- 1.5 Reissue Revised Statutes of Nebraska, Laws Applicable to the Nebraska Department of Transportation (Containing Chapter 3, Aeronautics; Chapter 39, Highways and Bridges; Chapter 49, Laws, Article 8, Definitions, Construction, and Citation; Chapter 60, Motor Vehicles, Article 6, Nebraska Rules of the Road; and Chapter 81, Article 7, Department of Transportation), July 2017 (<https://nebraskalegislature.gov/laws/browse-statutes.php>)
- 1.6 Nebraska Department of Transportation, NDOR/FHWA Stewardship & Oversight Agreement, October 2006 (<https://dot.nebraska.gov/business-center/fhwa/>)
- 1.7 American Association of State Highway and Transportation Officials, Roadside Design Guide, Washington, D.C., 2011.
- 1.8 Title 23 of the Code of Federal Regulations (*23 CFR*)  
(<https://www.fhwa.dot.gov/legregs/directives/cfr23toc.htm>)
- 1.9 Federal Highway Administration, Bridge Preservation Guide, U.S. Department of Transportation, FHWA, Washington, D.C., Spring 2018.  
(<https://www.fhwa.dot.gov/bridge/preservation/guide/guide.pdf>)



The designer should refer to the Design Process Outline for the current design process, activity order and activity numbers.

## Chapter Two

# Roadway Design Process

### 1. DESIGN PROCESS OUTLINE (<https://dot.nebraska.gov/business-center/design-consultant/>)

The Design Process Outline (DPO), (Ref. 2.1), summarizes the major activities to be completed during the course of project design. A copy of the current DPO, (Ref. 2.1), shall be used to track activities performed for each project. Activities in the DPO, (Ref. 2.1), are major work categories. Activities consist of groups of tasks. Tasks are steps to take to accomplish an activity. Upon completion of the tasks associated with a given activity, a major project benchmark is reached.

Not all activities will be required for all projects. All applicable tasks within each activity should be completed. Some tasks may occur simultaneously. The order in which tasks are completed does not necessarily have to follow the order in which they appear in the outline; however, some critical path tasks will need to be completed before proceeding on to the next activity. The designer should look at the activities and tasks before starting a project (or an activity) and decide which tasks are appropriate for the project and the priority they have for completion.

These design process activities are included in Clarity. Each activity number corresponds to an activity in Clarity. Clarity includes average times for completion of each activity associated with a project for project scheduling. The **Project Scheduling and Program Management Division** tracks the progress of all projects in Clarity, maintains this information and then updates the actual project schedule as activity completion dates are supplied. Estimated letting dates, based on the activity completion dates, are provided to other decision makers for prioritization and funding.

Completion dates should be recorded on the DPO, (Ref. 2.1), beside each applicable activity as activities are completed. The last task listed under each activity signifies the official completion of that activity. The dates of completion for each activity should be entered in Clarity.

Many of the activities in the DPO, (Ref. 2.1), seem to duplicate earlier tasks. This reflects the need to check and recheck information. This is especially true for projects that may extend over lengthy time periods. It is important to carefully check to be sure all items are included and nothing has been overlooked.

While not part of Clarity, the same activity numbers are also used on time sheets for employee timekeeping and payroll purposes. Time sheets should reflect the activity worked on in two-hour increments. Work on an activity in shorter time increments should be lumped together at the end of the week.

## 2. ENGINEERING REVIEW (ACTIVITY 5202)

The **Project Development Division** or the **Roadway Design Division** prepares an engineering review and scope determination for New and Reconstructed projects and for major 3R projects, (See **EXHIBIT 'O'** of the DPO, Ref. 2.1). For smaller safety projects and other projects of smaller scope, the **Roadway Design Division** may do the initial project review and setup under Activity 5308. See Chapter Thirteen: Planning and Project Development, Section 3, of this manual for additional discussion of the engineering review.

## 3. INITIAL PROJECT REVIEW AND SETUP (ACTIVITY 5308) (For projects without an Engineering Review)

On safety projects, the **District** usually will request safety improvements for a specific location. The **Roadway Design Division** will obtain the as-built plans, scope the project, develop a cost estimate and forward this information to the **Highway Safety Office** for a benefit/cost analysis. The **Safety Committee** will review the project to see if it meets the criteria for a safety project. If the appropriate criteria for a safety project are met, the **Safety Committee** reviews the request, may suggest recommendations, and approves the request. The **District Engineer** and others (e.g., **City, County**, etc.) must then approve the request. After approval, the **District Engineer** prepares the Highway Improvement Planning Request (NDOT Form 73) and forwards it to the **Deputy Director-Engineering** for approval.

The last action in Activity 5308 occurs when the designer submits the initial project review to the **Project Scheduling and Program Management Division** for incorporation into Clarity.

Roadway Design Division  
**Initial Project Scoping Data Sheet**

Date: .....  
 By: .....

1. Highway \_\_\_\_\_ Control No. \_\_\_\_\_  
 Ref. Post \_\_\_\_\_ Project No. \_\_\_\_\_  
 Length \_\_\_\_\_ Project Name \_\_\_\_\_
2. 20-Year Forecast Traffic Range \_\_\_\_\_ Trucks \_\_\_\_\_ Dr. Std. \_\_\_\_\_  
 Expressway \_\_\_\_\_ Priority Commercial \_\_\_\_\_ Sandhills Area \_\_\_\_\_
3. Typical Section Existing Proposed Standards  
 Driving lanes  
 Shoulders  
 Bridges
4. R.P.      L x W      S.R.      Proposed Work      sq. ft. Cost
5. Needs Study Deficiencies  
 Pavement Width \_\_\_\_\_ Shoulder Width \_\_\_\_\_ Sight Distance \_\_\_\_\_  
 Vertical Curves \_\_\_\_\_
6. Photolog Notes:
7. District Engineer Comments:
8. Proposed Work:
9. Estimated Cost  
 \_\_\_\_\_ Miles X \$ \_\_\_\_\_ /mile = \_\_\_\_\_  
 Bridges \_\_\_\_\_ X 1.18 (estimate increase) = \_\_\_\_\_  
 Miscellaneous \_\_\_\_\_ = \_\_\_\_\_  
 Add P.E. \_\_\_\_\_ % Utilities \_\_\_\_\_ E & C \_\_\_\_\_ % = \_\_\_\_\_  
 ROW \_\_\_\_\_ = \_\_\_\_\_  

Total Estimated Cost = \_\_\_\_\_

**Exhibit 2.1 Initial Project Scoping Data Sheet**

#### 4. PRELIMINARY ALIGNMENT DESIGN FOR BRIDGE HYDRAULICS (ACTIVITY 5306/5312)

Activity 5306/5312 consists of the preliminary design of the horizontal and vertical alignments, through any bridge areas on a project, for submittal to the **Bridge Division** for use in hydraulic analysis. This activity only applies to projects with bridge structures.

#### 5. PRELIMINARY ROADWAY DESIGN (ACTIVITY 5307/5309)

Activity 5307/5309 consists of data collection, data analysis and preliminary design tasks. For some projects, the first four tasks of this activity may be completed prior to a designer being assigned to the projects.

##### 5.A Obtain Preliminary Data

During Activity 5307/5309, survey information is processed by the **CADD Applications Unit** and sent to the appropriate **Roadway Design Unit Head**. A designer will be assigned to review the survey and the project data sheet and to identify missing topographic items by viewing the photolog.

If additional survey work is required, request a survey through the **Highway Geodetic and Preliminary Survey Supervisor**. If the survey information is sufficient, the survey is returned to the **CADD Applications Unit** for loading existing centerline(s) and cross-sections on the computer. If there is no surveyed alignment, the **Roadway Design Unit Head** sends as-built plans to the **CADD Applications Unit**. Terrain is only loaded on the workstation during the preliminary process if the project requires plan and profile sheets. The project is sent to the **Roadway Design Plans Development Unit** and the **Roadway Design Unit Head** so that the **Roadway Design Plans Development Unit** can create the base plans. Once the base plans are complete, the designer will then receive and review the plotted plans and/or electronic files from the **Roadway Design Plans Development Unit**.

The **Roadway Design Unit Head** will conduct a start-up meeting with the **Roadway Design Plans Development Unit, Right-of-Way**, and the designer to assign responsibilities for the development of preliminary plans. Either the designer or the design technician will be responsible for plan production and places the initial design in the file. Preliminary files are also made available, in electronic form, to the **Right-of-Way Division** so that they can begin Ownership right-of-way plans.

The roadway designer will create a project file, including information obtained from the **Project Development Division**. The designer will maintain the file until the project is constructed.

The designer should review the correspondence, the as-built plans and the engineering review or Highway Improvement Planning Request, (NDOT Form 73). Read the engineering review and/or the Initial Project Data Form (NDOT Form 333), and check to see if any environmental documentation will be required (See Chapter Thirteen: Planning and Project Development, Section 5, of this manual). The most current photolog should be examined looking for safety hazards, utility discrepancies, posted speeds, school or pedestrian crossings, differences from the preliminary plans, etc.



If conditions have changed in the field or the project scope has been changed from an overlay to a reconstructed section, a new survey will be needed. The request for new or expanded project surveys, right-of-way surveys, and utility surveys should be coordinated with the **Survey Coordinator**. At this time the designer should also determine the appropriate design standard and typical section for the project. He/she should also contact the **District Engineer** to obtain the balance factor.

## **5.B Project Scope Review and Scoping Changes**

The designer should review the project scope and alignment with the **Roadway Design Unit Head, Assistant Design Engineer**, and, if necessary, the **Roadway Design Division Engineer** and the **District Engineer**. If considerable time has passed since the project was originally programmed there may have been changes in design guidance or roadway conditions which will impact the scope of the project.

An updated cost estimate *must* be requested whenever a change in project scope occurs, (See Chapter Twelve: Cost Estimating & Funding, Section 6, of this manual). Because a change in project cost affects a **District's** budget, the **District Engineer** shall be involved in the decision making process regarding project scope changes.

Any changes in project scope which are initiated by the roadway designer or **Roadway Design Unit Head**, which are not included in the Engineering Review, (See Section 2 of this chapter), and/or the Plan-in-Hand Report, (See Section 8 of this chapter), require approval at different **NDOT** administrative levels depending upon the magnitude of the change in terms of funding required, length of project, etc. (changes from the Engineering Review that affect alignment or add temporary roads should be coordinated with the **Project Development Division**). Major scope changes, including changes to the project termini, will require a revised **NDOT Form 73**, "Highway Improvement Program Request", (See Chapter Twelve: Cost Estimating & Funding, Section 3.B, of this manual for additional information).

Copies of the approved changes in scope of the project which occur after the Engineering Review, (See Section 2 of this chapter), but before the Plan-In-Hand field inspection, (See Section 7.C of this chapter), shall be furnished to the **Deputy Director-Engineering, Division Head, District Engineer**, the **Utilities Unit of Roadway Design**, the **Environmental Permits Units of the Project Development Division**, and the **Project Scheduling and Program Management Engineer**. All additional **Divisions/Sections/Units** involved with the project shall be advised of the change in project scope.

Any change in the scope of the project occurring after the routing of the Plan-In-Hand Report, (See Section 8 of this chapter), which would have been included in the P.I.H. Report, (e.g., a change in project length or alignment), should be handled as a supplement to the report. At the initiation of the scope change the roadway designer should inform the recipients of the Plan-In-Hand Report (See **EXHIBIT 'I'** of the Design Process Outline (DPO), Ref. 2.1), that a supplement to the Plan-In-Hand Report is being prepared, listing the basics of the change. When the scope change is approved, the supplement to the Plan-In-Hand Report should be sent directly to each of the recipients of the P.I.H. Report (the supplement does not need to be routed through the list).

**Assistant Design Engineer** approval is required for any scope changes that result in:

1. Increases or decreases in project cost of approximately \$100,000 or less.
2. Increases or decreases in project length of 0.2 mi. or less.

**Division Head** or **District Engineer** approval is required for any scope changes that result in:

1. Increases or decreases in project cost of \$100,000 to \$500,000.
2. Increases or decreases in project length of 0.2 mi. to 0.5 mi.
3. Change from or to a resurfacing project from a full construction project.
4. Change from bridge widening to new bridge.

**Deputy Director-Engineering** approval is required for any scope changes that result in:

1. Increases or decreases in project cost of more than \$500,000.
2. Increases or decreases in project length of more than 0.5 mi.
3. Changes in type of surfacing, such as from asphalt to concrete.

### **5.C**      **Begin Preliminary Design**

The preliminary vertical and horizontal alignment is developed during Activity 5307/5309 including preliminary intersection and frontage road design, if applicable. The designer should discuss the alignment with the **Traffic Engineering Division** to coordinate lane configuration, signing, etc. Earthwork computations should be made after the horizontal and vertical alignment has been developed and surveys and balance factors have been obtained. If the **Project Development Division** has not prepared a location map, one should be drawn for public hearings and agreements.

### **5.D**      **Request Information from Other Divisions**

An accident records report for the project for the previous three years should be requested from the **Highway Safety Division**. This will include such information as an accident rate analysis, collision diagram, spot map, etc., as appropriate. This information is for **NDOT** use *only* and shall not be shared with the general public.

Obtain the load ratings for all bridges that are to remain in place from the **Bridge Division**. The **Bridge Division** will also provide structural analyses of bridge-size culverts (i.e., 20 feet in width measured along the roadway centerline) and a bridge data sheet. On reconstruction projects where the fill over an existing culvert (pipe or box) is to increase, the **Bridge Division** will provide, upon request, an analysis of structural capacity. Also, receive and review preliminary type, size and location (TS&L) sheets from the **Bridge Division**.

Wetland delineation plans should be obtained from the **Environmental Permits Unit** (See Chapter Thirteen: Planning and Project Development, Section 5.B, of this manual).

The **Materials and Research Division** will provide a preliminary pavement determination.

Activity 5307/5309 also includes the task to request additional survey(s) as needed. This is a reminder to check for missing or incorrect information such as pivots, water lines, sewers, utilities, right-of-way, new drives, culvert size, shelter belts, etc., and for extending cross-sections, pavement shots, wetlands, etc. Check construction books for culvert sizes.

Depending upon the type of project, the **Traffic Engineering Division** will provide special studies and recommendations for traffic engineering items. See Chapter Fourteen: Traffic, Section 1, of this manual for additional information.

Ordinarily, the **Utilities Unit of Roadway Design** keeps track of utility locations and will check surveys they receive from the **Project Development Division**. Occasionally, a designer may want to do this independently. For example, a utility may be noted during the plan-in-hand inspection that was not on the preliminary survey and the designer can then check on it.

To check the permits for utilities that are in the right-of-way, query the CICS1 program on IBM as follows:

1. Enter CICS1 by entering C1 and your DR# and password (the same process as accessing your time sheets).
2. Enter 8 to select Integrated Highway Inventory System.
3. Enter 22 to select Use and Occupancy Permits.
4. Enter 2 to Select Query.
5. Enter 3 to select Use and Occupancy Permit by Hwy/Cnty/Type/Status Query.
6. Enter the highway # and a reference post range – county, type and status may be left blank.

This shows a list of permits in the area selected.

Check for any recently issued utility permits and also check to see that all of the utilities are accounted for on the utility survey. Note that the desired utility location shown on the permit may not be the actual location of the utility. The **Utilities Unit** makes a final check of the locations of all utilities. Contact the **Permit Section** of the **Right-of-Way Division** and the **Utilities Unit** for assistance with details about permits.

### 5.E Drainage

The Drainage Design and Erosion Control Manual, Chapter One: Drainage, (Ref. 2.2), describes drainage design procedures. This activity will begin with determining if the project is in the floodplain and what types of control and what the allowable headwater is. Draw a drainage map and compute the drainage areas. Determine the Q values and size drainage structures. Contact the **Bridge Hydraulics Section** or the **Roadway Design Hydraulics Engineer** to discuss bridge sizes and other structure issues. Begin the following designs:

- Culverts and storm sewers.
- Special ditches.
- Median drains.
- Erosion and sedimentation control measures (preliminary).

### 5.F Initiate Special Investigations

Some projects may require special investigations. Special investigations should be initiated during Activity 5307/5309. The following topics may require special investigation:

- Drainage structures and box culverts requiring special design or special plans from the **Bridge Division**.
- Railroad agreement information from **Highway Liaison Manager** in the **Rail Unit** in the **Local Assistance Division**.
- Detours/temporary roads (e.g., road shifts, temporary road construction, phasing, etc.).
- Retaining walls.
- Soils investigation by the **Materials and Research Division** for compaction requirements, etc.
- Traffic signals and signing from the **Traffic Engineering Division**.
- Lighting from the **Roadway Design ITS/Lighting Unit**.
- Erosion control from the **Roadside Development & Compliance Unit (RDC)** of **Project Development**.
- Hazardous materials, electric substations, underground storage tanks, etc. from the **Project Development Division**.

Assemble the special provisions related to the above topics as they apply to the project.

#### 5.F.1 **Additional Survey**

At any time throughout the design activities, additional survey work may be needed. For example, a special drainage structure may require additional survey information because right-of-way is affected. Request additional survey work through the **Highway Geodetic and Preliminary Survey Supervisor**.

#### 5.F.2 **Traffic Engineering Review**

Coordinate roadway design with the **Traffic Engineering Division**. They will review the plans for compatibility of geometrics with traffic requirements.

### 5.G Aerial Photo Sheet Preparation

Consider the time since the previous aerial photo sheets were developed prior to public hearings. If the aerial photos, from which the public hearing displays are made, are less than 18 months old, they may be used for the public hearing. If project stations run the same, aerial photo sheets from the **Environmental Permits Unit** may be used.

The following information should be shown on the aerial photo sheets:

- Alignment.
- Stationing.
- Shifted alignment, if any.

As a general rule, existing wetlands need to be shown on air photo plans. See Chapter Thirteen: Planning and Project Development, Section 5.B, of this manual for information regarding wetlands.

### 5.H Utilities on Urban Projects

Cities are not required to have permits to occupy the right-of-way. Thus, it is important to determine any city-owned utility locations and possible conflicts by meeting with utility owners and the **Utility Coordinators**.

### 5.I Preliminary Access Control Determination

Determine preliminary access control during Activity 5307/5309 by:

- Obtaining relevant information from the **District Engineer** and others.
- Reviewing the zoning, existing and future land use.
- Conducting a field examination.
- Considering intersection sight distance, natural barriers, property lines, and the development of future frontage roads.

See Chapter Fifteen: Right-of-Way, Section 3, of this manual and the Access Control Policy to the State Highway System, (Ref. 2.3), (<https://dot.nebraska.gov/media/v45nhanu/access-control-policy.pdf>)

### 5.J Review Design Checklist

The last step in Activity 5307/5309 is to review the design checklist (See **EXHIBIT 'B'** of the DPO, Ref. 2.1). Go through the checklist and mark off the completed or required tasks, note of the tasks that will continue into the next activity, and be certain that all applicable tasks have been completed. Once the checklist has been reviewed, Activity 5307 ends. Note the completion date on the DPO, (Ref. 2.1), for the project and enter the date in Clarity. When the design checklist has been reviewed for this activity, stop charging time to Activity 5307/5309.

## 6. COST UPDATE 1 - STATUS 30 (ACTIVITY 5403)

The cost estimate checklist (EXHIBIT 'C' of the DPO, Ref. 2.1) should be checked to be certain that all applicable items for the project are incorporated into the cost estimate. Funding splits should be verified with the **Roadway Design Unit Heads** for projects within city limits and/or within railroad rights-of-way. The Project Information Sheet, (NDOT Form 342) should be updated and quantities should be submitted to the **Cost Estimating Unit** on Project Quantity Sheets, (NDOT Form 343). Submit the completed project information sheet and cost estimate forms to the **Roadway Design Unit Head** for his/her review. See Chapter Twelve: Cost Estimating & Funding, Section 4, of this manual for further details. Activity 5403 ends with the completion of the **Roadway Design Unit Head** review. Enter the date of completion in Clarity. Please note that Activity 5403 should not be used for annual cost updates in Clarity. Clarity does not schedule annual cost updates.

## 7. DESIGN PLAN-IN-HAND (PIH) (ACTIVITY 5315)

Activity 5315 is always an **NDOT** activity. If a **consultant** is responsible for design, this activity is a joint **Consultant/NDOT** activity. During Activity 5315, obtain right-of-way Ownership Plans from the **Right-of-Way Division**. See Chapter Fifteen: Right-of-Way, Section 2.C, of this manual for further information.

### 7.A Plan-in-Hand Plans

The plan-in-hand plans are prepared consisting of the:

- Location map.
- Typical section.
- Traffic data (on the typical section sheet).
- Wetland delineation plans sheets from the **Environmental Permits Unit**.
- Aerial sheets (if the project does not include wetlands).
- Plan and profile sheets.
- Large Scale sheets.

See Chapter Eleven: Highway Plans Assembly, Section 4, of this manual for an explanation of the various plan sheets.

The plans should include the following preliminary details:

- Earthwork balance points, quantities and balance factor.
- Line shifts (new geometrics).
- Limits of construction.
- Detailed limits of construction for urban areas.
- New grade line with vertical curve data and grades.
- Intersection designs, frontage roads, county road alignments, major commercial driveways.
- Begin and end project stations.
- Proposed culvert sizes (include Drainage Area, Design Q, and Headwater).
- Channel changes, if any.
- Preliminary storm sewer design in urban areas.

- Edge of pavement, drives and walks in urban areas.
- Project centerline and surveyed baseline on an aerial photo sheet.
- Areas of impacted wetlands.
- All available aerial and underground utility facility locations (electrical, telephone, pipelines, gas, cable TV, etc.).

Plans submitted to the **Utilities Coordinator** will require the most up-to-date details on the items listed in **EXHIBIT 'G'** of the DPO, (Ref. 2.1).

Contact the **Utilities Unit** to coordinate activities related to any utility conflicts.

### **7.B Plan-in-Hand Plan Distribution**

The plan-in-hand plans including location map and typical section, stamped preliminary and dated, should be distributed to the entities shown in **EXHIBIT 'F'** of the DPO, (Ref. 2.1), at least two weeks prior to the inspection date. Use the Design Plans Transmittal form, (NDOT Form 135), and the Letter of Transmittal form, (NDOT Form 480), for submittal and notification of plan availability. NDOT Form 135 should be used for transmittals within **NDOT**, and NDOT Form 480 should be used for other agency transmittals, e.g., cities, counties, consultants, other state agencies, etc.

### **7.C Conduct the Plan-in-Hand Inspection**

The plan-in-hand inspection is a field inspection of the proposed project by the **District Engineer, FHWA** (if they have oversight, see Chapter One: Roadway Design Standards, Section 10.A, of this manual), **City/County Representatives, Utilities Coordinator, Roadway Design Unit Head, Assistant Design Engineer** and the designer. Use the checklist shown in **EXHIBIT 'H'** of the DPO, (Ref. 2.1), as a reference to note any items that need to be addressed during the plan-in-hand inspection or may be noted during the inspection. The following items should be taken to the plan-in-hand inspection:

- Camera, 100 foot tape, hand level.
- Safety vest, cap/hard hat, strobe light.
- One set of half-size cross-sections.
- One set Stage II right-of-way plans.
- Four sets of half-size plans.
- Plan-in-hand checklist.
- Correspondence file(s).
- Contact aerial photos.
- Drainage maps/worksheets.
- Erosion control checklist.

If there are changes to the project resulting from the plan-in-hand inspection, the designer will meet with the **Environmental Program Manager** to review the changes and to determine if changes to the pre-permit application consultation process will be necessary.

Following the plan-in-hand inspection, consolidate all sets of comments into one set of plans, label the set as official plan-in-hand plans and place them on file. These plans are then a milestone document for the project. This activity is the end of Activity 5315. Enter the completion date in Clarity.

## 8. PIH REPORT (ACTIVITY 5318/5338)

This activity consists of the preparation and review of the plan-in-hand report. An optional meeting may be held with the **Assistant Design Engineer** and **Division Head** to discuss the plan-in-hand prior to the completion of the plan-in-hand report. The plan-in-hand report, location map, accident report, engineering review statement and other miscellaneous attachments, as appropriate, are routed to the appropriate individuals for review and approval as listed in **EXHIBIT 'I'** of the DPO, (Ref. 2.1).

Please note the plan-in-hand report may go back and forth several times before the final report is approved. The **Roadway Design Office Manager** incorporates all the approved changes and then submits them for signatures.

The plan-in-hand report outline should be followed (See **EXHIBIT 'I'** of the DPO, Ref. 2.1). An abbreviated report format may be used for off-system projects. Note that starred topics must have comments attached for all projects. A list of possible safety enhancements is shown in **EXHIBIT 'I'** of the DPO, (Ref. 2.1).

On resurfacing projects, or projects not requiring additional right-of-way, add the following statement to the plan-in-hand report:

A special provision will be written to remove those trees that are inside the Horizontal Clear Zone, but not beyond the limits of existing right-of-way.

Once the appropriate parties approve the plan-in-hand report, copies are released for additional distribution. Copies of the plan-in-hand report with location maps and any miscellaneous attachments are distributed to the individuals or agencies listed in **EXHIBIT 'I'** of the DPO, (Ref. 2.1). This marks the end of Activity 5318/5338. Enter the completion date in Clarity.

## 9. ROADWAY FUNCTIONAL DESIGN (ACTIVITY 5316/5326)

Roadway functional design (activity 5316/5326), incorporating comments from the plan-in-hand field inspection and the Public Information Meeting, (if held), may begin while the plan-in-hand report is being circulated for approval. The designer may need to revise the plans based on comments from the Public Information Meeting and from the final plan-in-hand report. One of **NDOT's** goals is to have as much of the final design accomplished as possible at the functional design stage (Activity 5316). The only changes to the project design after the functional design stage should be as a result of the design public hearing, unanticipated utility problems or changes as a result of right-of-way negotiations.

The designer should conduct a post-plan-in-hand meeting (Meeting "B") with the **Roadway Design Plans Development Unit** and **Roadway Design Unit Head** to coordinate making the necessary changes (See **EXHIBIT 'A'** of the DPO, Ref. 2.1). Design details to be considered may also include locations of borrow and/or waste pit sites, guardrail locations, etc. Erosion control design should also be coordinated with the **Roadside Design Section**.

The functional design plans should then be sent to the **Environmental Permits Unit** with the preliminary design showing impacted wetlands, possible mitigation sites, any proposed channel change locations including typicals and justification for both impacted wetland and channel



changes, i.e., why avoidance was not possible. Plans for public hearing meetings should show existing wetland sites. The decision will be made at the dry run whether to show potential mitigation sites. The designer should search potential mitigation sites for the most appropriate site and make a recommendation at the dry run. Coordination with the **Environmental Permits Unit** is essential in determining the number of acres (hectares) impacted and the most appropriate mitigation site. See Chapter Thirteen: Planning and Project Development, Section 5.B, of this manual for further discussion of wetlands procedures.

Special investigations may also be updated as needed during Activity 5316/5326 for such items as drainage structures, railroad agreement information, detour/shoofly, retaining walls, stairs (from the **Bridge Division**), soils investigation, phasing, traffic, lighting, signing, erosion control. Again, additional surveys may be required for mitigation sites, borrow/waste pits, etc. The **Traffic Engineering Division** may also need to review the updated plans.

### **9.A**      Special Provisions

Activity 5316/5326 also includes the initial writing of any special provisions that may be needed for the project. This information accompanies the computations for the Plans, Specifications and Estimates (PS&E) package.

### **9.B**      Initiate Agreements

The **Roadway Design Division** initiates agreements by completing the Request for Agreement form (NDOT Form 65). The request form is forwarded to the appropriate division for processing. The designer should keep track of the agreement progress and provide any necessary display information. Agreements go to the **District Engineer** to obtain signatures from other parties to the agreements. See DOT-OI 45-5, "Agreements" (Appendix B, "Selected NDOT Operating Instructions") for further information regarding agreements.

#### **9.B.1**      City Agreements

All projects within city/municipal limits that are designed to 3R standards or higher will require a city agreement. The **Project Development Division** prepares city agreements based on information obtained from the **Roadway Design Division**. City agreements may be developed for such things as maintenance and operation of roadway lighting including poles beyond city limits. See Chapter Thirteen: Planning and Project Development, Section 6.A, of this manual for further information.

On all city agreements city limits should be described by stationing or reference post, either prior to Section 1 of the agreement or on the cost estimate sheet. Also note if the city limits encompass the entire highway right-of-way or one side only. The transmittal letter for the agreement should be sent from the **Roadway Design Unit Head** through the **Assistant Design Engineer** to the **District Engineer**.

City agreements will not be required, with the **District Engineer's** approval, on Maintenance projects.

### 9.B.2 Irrigation Agreements

The **Project Development Division** works with the appropriate **Water Districts** regarding irrigation agreements.

### 9.B.3 Railroad Agreements

The **Highway Liaison Manager** in the **Rail Unit** in the **Local Assistance Division** is responsible for all agreements, easement documents, and railroad special provisions. The designer should realize that some agreement and easement documents take considerable time to be executed. Early coordination is essential.

When there is railroad involvement but an agreement and/or easement are not needed, the **Rail Unit** in the **Local Assistance Division** will draft railroad special provisions to add to the letting package. See Chapter Ten: Miscellaneous Design Issues, Section 1, of this manual for further information.

### 9.C Design Access Control

Once the roadway designer is prepared to make recommendations regarding access control, he/she should contact the **Highway Right-of-Way Associate** in the **Property Management Section** of the **Right-of-Way Division** and request to be on the agenda for the next access control meeting. The designer presents his/her recommendations to the **Control Access and Permit Review Committee** with the necessary supporting documentation. Access control is required on all Interstate, expressway and four-lane divided highways. The department will consider acquiring access rights on all other highways when:

1. The 20 year forecast traffic (ADT) is 3001 or greater, as shown on the department's current 20 Year Forecast Traffic Map: or
2. The route is within the present or projected two mile zoning limits of first class cities (population 5,000 to 99,999) and within the present or projected three mile zoning limits of primary (population 100,000 to 299,999) and metropolitan class cities (population more than 300,000); or
3. There are three miles or less between the Interstate and the connecting or parallel highway.
4. At other locations deemed appropriate.

The designer should provide an aerial photo with property lines and locations of access sites that meet the policy for the committee's review and approval. The designer may need to take the project to several access control meetings throughout the design process.

**EXHIBIT 'K'** of the DPO, (Ref. 2.1), lists the necessary documentation needed for access control meetings at various project stages. See Chapter Fifteen: Right-of-Way, Section 3, of this manual for additional discussion of access control. Document the results of the access control meetings in the project file and route the information through the **Roadway Design Engineer, Project Development Engineer, Right-of-Way Manager** and the **Highway Right-of-Way Associate**.

#### 9.D Receive Additional Documentation

If the project has a Class I or Class III environmental classification, a draft environmental impact statement (DEIS) or draft environmental assessment (DEA), as appropriate, will be submitted to the **Roadway Design Division** from the **Project Development Division**. See Chapter Thirteen: Planning and Project Development, Section 5.A, of this manual for additional discussion.

The **Materials and Research Division** will also submit an approved pavement determination to the designer, see Chapter Eight: Surfacing, Section 1.B, of this manual for additional information. This is an indicator that a cost update will be due.

#### 9.E Notifications

Notify the **Public Hearings Officer** of the availability of plans for projects that will not have public hearings. Plans will be available to the public in the **District Engineer's** office. See Section 12 of this chapter for further information regarding public notification and public hearings.

#### 9.F Design Relaxations

If a design relaxation is necessary, the request for relaxation should be submitted to the **Director-State Engineer**, the **Nebraska Board of Public Roads Classifications and Standards**, and/or the **Federal Highway Administration**, as appropriate. Chapter One: Roadway Design Standards, Section 10, of this manual, discusses the design relaxation process in further detail.

#### 9.G Submit Functional Plans

Functional plans, also known as hearing plans, should be submitted to the individuals and agencies shown in **EXHIBIT 'F'** of the DPO, (Ref. 2.1). If a public hearing is to be held, these plans shall be submitted to the appropriate entities five weeks prior to the public hearing. Functional plans should be stamped preliminary plans and dated. This is the end of Activity 5316/5326. Enter the completion date in Clarity.

## 10. COVENANT RELINQUISHMENT AGREEMENT

A covenant relinquishment agreement (CRA) is a signed agreement between **NDOT** and a **City/County** in which **NDOT** maintains ownership of the right-of-way for utility easement purposes but relinquishes responsibility for the maintenance and operation of the roadway facility to the **City/County**. In a CRA, **NDOT** agrees to bring the roadway surfacing up to an acceptable serviceability value. The designer will need to get a determination from the **District Engineer** and/or the **Project Scheduling and Program Management Division** on whether the surfacing of the relinquishment should be added to the project or if a separate project should be programmed, unless the relinquishment is part of an expressway project, in which case the cost to improve the relinquishment will be a project cost. The scope of work on the segment to be relinquished must be justified and be approved on a scoping document, such as the plan-in-hand report or a revised NDOT Form 73 (“Highway Improvement Programming Request”).

The designer should review any CRAs that may have been developed to determine if new or revised CRAs are needed. If a new CRA is required or revisions are needed, the designer shall provide the necessary information for the documents. The approximate location should be identified and a location map exhibit should be prepared by the **Roadway Design Plans Development Unit**. Submit the information for the CRA to the **Materials and Research Division**. Review the draft CRA and exchange comments. A signed agreement must be received prior to scheduling a dry run for a public hearing, (See Section 12 of this chapter for further information regarding public hearings). For further information on relinquishments see Section 21 of this chapter; Chapter Fifteen: Right-of-Way, Section 7.D, of this manual; and The Department of Transportation Operating Instruction 60-13, “Relinquishment of Roads from the Highway System” (Appendix B, “Selected NDOT Operating Instructions”, of this manual).

## 11. COST UPDATE 2 -STATUS 40 (ACTIVITY 5406)

Review the cost estimate checklist (**EXHIBIT ‘C’** of the DPO, Ref. 2.1) for the project. Check for funding splits on the Initial Project Data form, (NDOT Form 333), or the Project Data Revision form, (NDOT Form 334) and/or on CICS1/CICS3. Quantities should be submitted to the **Cost Estimating Unit** on Project Quantity Sheets, (NDOT Form 343), and the Project Information Sheet, (NDOT Form 342), should be updated. Submit the completed project information sheet and cost estimate forms to the **Roadway Design Unit Head** for his/her review. The last task in Activity 5406 is the completion of the **Roadway Design Unit Head’s** review. Enter the completion date in Clarity. Do not sign off on Activity 5406 in Clarity when completing an annual cost update. See Chapter Twelve: Cost Estimating & Funding, Section 4, of this manual for further details.

## 12. DESIGN PREPARATION FOR PUBLIC HEARINGS (ACTIVITY 5323/5324)

### 12.A Public Hearings

A public hearing is an advertised formal meeting, presided over by a **Highway Commissioner**, to present the proposed project to the public and to obtain public input. Design functional plans (Activity 5316) and R.O.W. ownership plans are needed for this meeting. Before scheduling the public hearing the designer will need to obtain a signed city covenant agreement (if applicable), a signed covenant relinquishment agreement (if needed) and a signed draft environmental document and noise study, if a noise study was conducted. These documents are required before a public hearing may be scheduled. Hearing guidelines must be followed for proper public notice of the hearing, for information that must be presented, and for the hearing procedures. A transcript is made of the verbal and written testimony. Location public hearings and design public hearings may be held separately or they may be combined into one hearing. See “Guidelines for Public Hearing”, **EXHIBIT ‘M’** of the Design Process Outline, (Ref. 2.1), for further information

The following items should be collected and/or prepared for the public hearing:

- Comments from Public Information Meeting, if applicable.
- Design year traffic information (i.e., design year is 20 years after the year of construction completion).
- Typical section display.
- Aerial photo display (less than 18 months old).
- Hearing plans (See **EXHIBIT ‘F’** of the DPO, Ref. 2.1).
- Engineering statement (take 5-10 extra copies to the hearing for the **Highway Commissioner** to give to the media).

A dry run should be held six weeks prior to a proposed public hearing. **EXHIBIT ‘L’** of the DPO, (Ref. 2.1) lists people who should be invited to a dry run. Contact the **Design Standards Engineer** for a current list of people who should be invited. Be sure that the **Director-State Engineer**, the **Deputy-Director Engineering** and the **Roadway Design Division Engineer** are available to attend. Others may be invited when appropriate. The **District Engineer** should also be contacted and asked if he/she would like to attend the dry run. The dry run should simulate an actual public hearing. It provides the opportunity to practice and refine the presentations prior to an actual public hearing. The public hearing checklist (**EXHIBIT ‘M’** of the DPO, Ref. 2.1) should be used to gather information and tools for the dry run and the public hearing.

A “Public Hearing Notice Worksheet”, (**EXHIBIT 2.2**), a “Fact Sheet” (**EXHIBIT ‘S’** of the Design Process Outline, Ref. 2.1), a detour map (if applicable) and a current location map is to be submitted to the **Public Information Office** in the **Communications Division** prior to the dry run. After the dry run is completed, the designer provides the **Secretary of the Highway Commission** and the **Public Hearings Officer** with a copy of the engineering statement. The **Public Hearings Officer** will provide the designer with a copy of the presentation including exhibits that will be used during the hearing. The **Public Hearings Officer** advertises the hearing in the official county newspaper and in general circulation newspapers in the project area at five and at two weeks prior to the hearing date.

The designer is responsible for providing the **District** and **City** (if applicable) with a set of design functional plans at the same time as the advertising information is submitted to the **Public Hearings Officer**. After the hearing, the designer will submit a copy of the engineering statement to the **Secretary of the Highway Commission**.

Public hearings will be held for all environmental Class I projects, (those requiring an environmental impact statement), and environmental Class III projects, (those having an environmental assessment) (See Chapter Thirteen: Planning and Project Development, Section 5, of this manual). All environmental Class II projects, (categorical exclusions), are reviewed on an individual basis to determine if a hearing will be held. The plan-in-hand report will note the decision made. All environmental Class I and III projects will require **State Highway Commission** recommendation and the **Governor's** approval, as will any Class II project for which a public hearing is held. Public Hearing Statements should include some environmental statements, such as:

- Thoughtful design and construction techniques are used to minimize the impacts to the environment, wetland areas will be avoided when possible and replaced when eliminated.
- Temporary erosion and sediment control measures will be used to reduce soil erosion.
- Trees will be saved where consistent with good design.
- On this project some trees are located within the proposed construction limits and will be removed.
- After construction, disturbed areas will be seeded with grasses and wildflowers chosen based upon the soil type and compatibility with the surrounding vegetation.

After the hearing is over, the designer reviews and consolidates comments that were made, and compiles the plans, displays and hearing statement for the permanent file as hearing plans. Comments from the afternoon informal session are put in one set of plans and stamped as public hearing documents.

The completion date for Activity 5323 occurs at this point for solely roadway design tasks. Enter the completion date in Clarity at this time. Other divisions share responsibility for the rest of the tasks in Activity 5323. Designer time associated with public hearing tasks should be charged to Activity 5323 even after the completion date has been entered in Clarity.

## 12.B Highway Commission Statement

After the public hearing has been held, the designer or **Roadway Design Unit Head** shall prepare a Highway Commission statement, (forms may be obtained from the Roadway Design vault). The statement will be presented to the **Highway Commission**. The **Assistant Design Engineer** reads the statement into the **Highway Commission** proceedings, summarizes the comments received at the public hearing, and answers questions. A copy of the statement goes to the **Highway Commission Secretary**. Upon receipt of approval from the **Highway Commission** and the **Governor**, the project proceeds. Receipt of approval marks the end of Activity 5323 for time sheets.

## 12.C Public Meetings

Communication between **NDOT** and the public is an important ongoing activity coordinated by the **Public Hearings Officer** in the **Communications Division**. Depending on the nature of the project, several types of contact may be made during the course of a project. The **Public Hearings Officer** publishes notices for hearings in general circulation newspapers in project areas to provide information about the proposed projects to the public. Types of public meetings that are held are:

- Public Information Meetings.
- City and/or County Officials Meetings.
- Property Owners Pre-Hearing Meetings.
- Pre-hearing Information Meetings.
- Location Public Hearings.
- Design Public Hearings.

For guidance on which type(s) of public meeting(s) should be held for a project see the “Public Meeting Checklist”, **EXHIBIT ‘R’** of the Design Process Outline (Ref. 2.1). Plan and agreement requirements for the various types of public meetings may be found in EXHIBIT 2.2.

Meeting Type	Design Plans (Activity #)	Environmental Permits Unit Plans	R.O.W. Plans	Signed Agreements (As Necessitated by the Project)
“Preliminary/Input From Public” Information Open House	Preliminary Plans (#5315)	Wetlands Impacts and Potential Mitigation Sites	Ownership	
“In Lieu Of A Hearing” Information Open House	Functional Plans (#5316)	Wetlands Impacts and Preferred Mitigation Site(s)	Ownership	City Covenant Agreement Covenant Relinquishment Agreement Draft Environmental Document(s) * or a FONSI **
“Pre-Design Hearing” Information Open House	Functional Plans (#5316)	Wetlands Impacts and Preferred Mitigation Site(s)	Ownership	City Covenant Agreement Covenant Relinquishment Agreement Draft Environmental Document(s) * or a FONSI **
Property Owners Pre-Hearing Meeting	Functional Plans (#5316)	Wetlands Impacts and Preferred Mitigation Site(s)	Ownership	City Covenant Agreement Covenant Relinquishment Agreement Draft Environmental Document(s) * or a FONSI **
Corridor Hearing	Functional Plans (#5316)	Wetlands Impacts and Potential Mitigation Sites	Ownership	Covenant Relinquishment Agreement
Public Hearing	Functional Plans (#5316)	Wetlands Impacts and Preferred Mitigation Site(s)	Ownership	City Covenant Agreement Covenant Relinquishment Agreement Draft Environmental Document(s) * or a FONSI **
City and/or County Officials Meeting	Functional Plans (#5316)	Wetlands Impacts and Preferred Mitigation Site(s)	Ownership	City Covenant Agreement Covenant Relinquishment Agreement Draft Environmental Document(s) * or a FONSI **
“Project Update” Information Open House	Functional Plans (#5316) or Better (if available)***	Wetlands Impacts and Preferred Mitigation Site(s)	Ownership or Better (if available)***	City Covenant Agreement Covenant Relinquishment Agreement Draft Environmental Document(s) * or a FONSI **
“L.O.C./Phasing” Information Open House	L.O.C. Plans (#5335)	Wetlands Impacts and Preferred Mitigation Site(s)	Appraisal***	City Covenant Agreement Covenant Relinquishment Agreement Draft Environmental Document(s) * or a FONSI **
Information Meeting Prior to Appraisal and Acquisition	L.O.C. Plans (#5335)	Wetlands Impacts and Preferred Mitigation Site(s)	Appraisal***	City Covenant Agreement Covenant Relinquishment Agreement Draft Environmental Document(s) * or a FONSI **

\* Includes a Noise Study, if one was conducted.

\*\* An Environmental Assessment with a Finding Of No Significant Impact

\*\*\* All required final environmental documents must be signed before R.O.W. Appraisal and Final Design Activities (#5355) can begin.

For further information see Sections 9 and 16, Chapter Thirteen: Planning and Project Development, (Section 5), and Chapter Fifteen: Right-of-Way, Sections 3.F & 4, of this manual.

### Exhibit 2.2 Plan and Agreement Requirements for Public Meetings



### 12.C.1 Public Information Meetings

Public information meetings are advertised meetings held to inform the public of the proposed project location and/or design, to obtain public input and to answer questions through one-on-one conversations with the public. These are not recorded meetings but citizen Comment Sheets are made available.

The required plans and agreements for these meetings may be found in [EXHIBIT 2.2](#). Items that should be taken to a public information meeting may be found on the “Public Meeting Checklist” in [EXHIBIT ‘M’](#) of the [Design Process Outline](#) (Ref. 2.1). Items 5 through 9 and 11 through 26 are usually sufficient for a public information meeting, but items 2 through 4 may be added if a mosaic is available. The designer should create a “Project Fact Sheet”, [EXHIBIT ‘M’](#) of the [Design Process Outline](#) (Ref. 2.1), for distribution at the public information meeting.

Public information meetings are scheduled in coordination with the **District Engineer** and/or the **Project Development Division** and the **Communication Division**. Meetings usually are held for major relocations and location studies, right-of-way appraisal, design and scope changes, wetlands impacts, projects in villages and cities, and sometimes for an engineering review. There are various types of public information meetings:

- A **“Preliminary/Input from the Public” Information Meeting** is often scheduled to solicit public input prior to putting proposed design features on a map. This meeting may be held in concert with the plan-in-hand.
- An **“In Lieu of a Hearing” Information Meeting** is held when the public has indicated there is significant interest in the project but no public hearing is planned. This may also be used in the case of a Class II environmental classification project (See Chapter Thirteen: [Planning and Project Development](#), Section 5, of this manual).
- An **“Information Open House”** meeting is always held in the afternoon of a design hearing.
- A **“Project Update” Information Meeting** is held when 18 months or more have elapsed since a design hearing was held or when there has been a change in the scope of the project.
- A **“Limits of Construction/Phasing of Construction” Information Meeting** is held to inform adjacent property owners of the possible impacts to their property. In metropolitan areas, these meetings are often held only with homeowner groups that are affected by the project. If there are fewer than four affected properties, and no public information meeting is held, LOC Design Plans (Activity 5335) will be sent to the **District Engineer** who will be asked to contact the property owners, showing them our proposed design and explaining its impact to their property.
- An **Information Meeting Prior to Appraisal and Acquisition** is held to answer questions regarding the project and the **Department of Transportation** property acquisition process. Landowners impacted by the project are particularly encouraged to attend. The preliminary R.O.W. plans must have been completed before this meeting. This is a meeting held by the **Roadway Design Division**, which may be attended by appraisers from the **R.O.W. Division**. Factors considered in selecting a Pre-Appraisal Information Open House include: a decision by the **Assistant Design Engineer**, a request from the **District Engineer** or **DOT Administration**, elapsed time since a previous meeting with the public, etc.

The designer should submit a “Public Hearing Notice Worksheet”, (EXHIBIT 2.3), a “Fact Sheet” (EXHIBIT ‘S’ of the Design Process Outline, Ref. 2.1), a detour map (if applicable) and a current location map to the **Public Hearings Officer** five weeks prior to a proposed information open house so that the required meeting advertising and official notifications may be produced. The first publication occurs three weeks prior to the meeting and the final publication will be one week prior to the meeting. The designer is responsible for providing the **District** and (if applicable) the **City/Village** office with a set of plans at the same time that the advertising information is sent to the **Public Hearings Officer**. See Section 12.A of this chapter for additional information.

After each meeting all notes from the various plans and note pads shall be consolidated onto one set of plans and/or one set of minutes. The minutes will become part of the project file and the plans shall be properly tagged as “Information Meeting” or “Public Hearing” plans and will be kept until the project has been built. It is the responsibility of the designer to ensure that all promises for studies, phasing, and/or plan changes are honored and that any information received that affects other divisions is shared.

### 12.C.2 City and/or County Officials Meeting

The **Assistant Design Engineer** will determine when a **City and/or County** officials meeting is to be held. While it is not necessary that the **Roadway Design Division** conduct all of the meetings and coordination, such as in utilities conflicts, they are responsible for seeing that it is accomplished. The plan and agreement requirements for this meeting may be found in EXHIBIT 2.2.

### 12.C.3 Property Owners Pre-Hearing

Pre-hearing meetings may be held with impacted property owners on projects entailing major changes in access, parking, drop off lanes, right-of-way, driveways, relocation (especially of occupied residences), etc. The **Assistant Design Engineer** will determine when a property owner pre-hearing will be held. See EXHIBIT 2.2 for the required plans and agreements for this meeting.

## Public Hearing Notice Worksheet

*Please return to the Public Information Office in the Communication Division  
 prior to your hearing dry run or scheduling of your open house.*

Your Name:		Division, Section, Unit:	
Phone No.:	Fax No.:	Type of Hearing: <i>(Check one)</i> <input type="checkbox"/> Notice of highway corridor hearing <input type="checkbox"/> Notice of highway design hearing <input type="checkbox"/> Notice of information open house <input type="checkbox"/> Pre-appraisal meeting <input type="checkbox"/> Other <i>(please specify)</i>	
Date of Hearing:			
Time of Hearing or Information Meeting: Starting: _____ Ending: _____ <i>(if appropriate)</i>			
Hearing Location: <i>(Building, Address, and City)</i>  		Time of Preceding Information Discussions, if any: Starting _____ Ending _____	
Project No(s). and "Known As" Descriptions:		Division(s) and/or District(s) Providing Personnel for Informal Discussions: <input type="checkbox"/> Roadway Design <input type="checkbox"/> Project Development <input type="checkbox"/> Right-of-Way <input type="checkbox"/> District	
		Control No.: <i>(For internal referencing only)</i>	
Briefly Describe Location and Type of Proposed Improvement: <i>(Major Elements)</i>  			
Total Lanes in the Completed Project:		Project to be Constructed Under Traffic? <input type="checkbox"/> Yes <input type="checkbox"/> No	
Highway Access Control Information:			

Detour Information:		
Shoo-fly Information:		
Right of Way Information:		
Roadway Removal, Relinquishment:		
Acquisition of Business, Residence or Other Structures:		
Environmental Areas, including Wetlands to be Affected by the Project:		
Location and Address Where Preliminary Plans may be Inspected:	Contact Person for News Release:	
	Phone No.: <i>(Include Area Code)</i>	
	Have you attached the most current map detailing the location of the proposed improvement? <input type="checkbox"/> Yes <input type="checkbox"/> No	
Is the project politically sensitive? <i>(Explain – for background purposes only)</i>		
Section/Unit Manager Reviewing & Approving Hearing Notice Materials:	Phone No.:	Fax No.:

**Exhibit 2.3 Public Hearing Notice Worksheet (Continued)**

### 13. ROADWAY DESIGN (ACTIVITY 5325/5327)

Activity 5325/5327 begins with a review of the hearing plans and the public hearing transcript. Typical cross-sections should be updated as necessary. The **Materials and Research Division** will provide the final typical pavement cross-sections.

Design of geometrics and grades for driveways, intersections, frontage roads and cross-sections should be completed during this activity. Compute impacted wetlands and submit them to the **Environmental Permits Unit** for recommendations regarding elevations and mitigation.

Finalize any special investigations such as drainage structures, box culverts, railroad agreement information, detours/temporary roads, construction phasing, retaining walls, soils investigations, traffic signals, lighting, signing, marking, wetlands mitigation plans, erosion and sedimentation control measures (both temporary and permanent). Review the design checklist (**EXHIBIT 'B'** of the DPO, Ref. 2.1). Order additional surveys, if necessary. Have the **Traffic Engineering Division** review any pertinent changes.

Submit plans to the **Roadway Design Plans Development Unit** for final plan preparation upon completion of the special investigations. The end of Activity 5325 coincides with the scheduling of the **Roadway Design Division** review meeting (See Activity 5335). Enter the completion date in Clarity.

### 14. ROADWAY DESIGN REVIEW/LIMITS OF CONSTRUCTION PLANS (ACTIVITY 5335/5336)

The **Roadway Design Division** review meeting with the **Roadway Design Unit Head** is the first task in Activity 5335/5336 and is held to check the plans using the design checklist (**EXHIBIT 'B'** of the DPO, Ref. 2.1), the plan-in-hand plans, and the hearing plans.

#### 14.A Limits of Construction Plans

The limits of construction plans should show the final limits of construction including all culverts, driveways, intersections, dikes, etc. and taking into account the needs of **ITS, Lighting, Utilities, RDC, Wetlands, and Traffic**. Distribute the limits of construction plans with location maps and typical sections to the entities shown in **EXHIBIT 'F'** of the DPO, (Ref. 2.1). The plans should be stamped preliminary and dated.

After L.O.C. plans have distributed, notice should be given when changes are made to the L.O.C. plans that may affect **R.O.W. Design, Utilities, Bridge, Traffic, the Wetlands Unit** or other divisions. Some examples of changes:

- Construction Limits.
- Special Ditches (even if within the planned R.O.W., it may affect utilities).
- Vertical Profile.
- Intersection/Drive Locations.
- Temporary Roadways, etc.
- Impacts to Wetlands areas.

**R.O.W. Design, Utilities** and any other affected sections/units shall be notified when work is beginning on a change. Send an E-mail to:

- **R.O.W. Design Engineer.**
- **ROW Designer.**
- **Utilities Unit ADE.**
- **Utility Coordinator.**
- **Wetlands Unit.**
- Other affected sections.

The notification shall include the following information:

- Project Name & Number.
- Control Number.
- Tract Numbers affected.
- A brief description of the changes.
- An approximate completion date.

#### **14.B      Other Tasks in Activity 5335**

A meeting with the **Traffic Engineering Division** may be held to review any unusual situations related to traffic concerns, e.g., intersection, pavement marking plans, etc. Typically, the **Traffic Engineering Division** is simply notified that the limits of construction plans are available (See **EXHIBIT 'F'** of the DPO, Ref. 2.1). In addition, the **ITS/Lighting Unit** should be given a set of base plans if there is lighting involved.

Any covenant city agreements should be completed and sent to the **District Engineer** to obtain signatures. The final task in Activity 5335 is a meeting of **Right-of-Way**, the **Roadway Design Plans Development Unit**, **Roadway Design Unit Heads**, **Assistant Design Engineers** and the **Utilities Coordinator**. Enter the completion date in Clarity.

#### **15.            COST UPDATE 3 - STATUS 45 (ACTIVITY 5408)**

Review the cost estimate checklist (**EXHIBIT 'C'** of the DPO, Ref. 2.1) for the project to be certain all items are included. Recheck the funding splits on the Initial Project Data form, (NDOT Form 333), the Project Data Revision form, (NDOT Form 334), and/or on CICS1/CICS3. The Project Information Sheet, (NDOT Form 342) should be updated and updated quantities should be submitted to the **Cost Estimating Unit** on Project Quantity Sheets, (NDOT Form 343). Submit the completed project information sheet and cost estimate forms to the **Roadway Design Unit Head** for his/her review. See Chapter Twelve: Cost Estimating & Funding, Section 4, of this manual for further details. The last task in Activity 5408 is completion of the **Roadway Design Unit Head** review. Do not use Activity 5408 to record annual cost updates in Clarity.

## 16. DESIGN REVIEW SUPPORT PROCESSES (ACTIVITY 5340)

The designer should review the scheduled letting date, the anticipated time to construct the project, etc. in Clarity to be certain the schedule is still on track. Review the schedule, keeping the following (and other similar) activities and concerns in mind:

- **Agreements:** city, county, irrigation, and railroad. Recognize that some city/county councils may only meet once a month. Also be aware that irrigation modifications can only be done during that part of the year when there is no water in the systems. Railroad owners may be out of state, and agreements require extended lead-time.
- **Final Relinquishment Agreement:** agreements must be executed prior to submittal of the plans package to **PS&E** (See Section 21 of this chapter).
- **Wetlands:** permitting requires input from multiple agencies; mitigation should be done in winter months, if possible.
- **Utilities:** seasons are also critical for utility relocation.
- **Right-of-way:** acquisition is a lengthy process (See Chapter Fifteen: Right-of-Way, Section 5, of this manual).
- **Soils:** surcharge and settlement may need to be programmed into the construction schedule.
- **Phasing:** coordinate bridge and roadway construction phasing, etc.
- **Promises:** be aware of promises made, e.g., construction completed before football season.
- **Logo signs:** tourist-oriented directional (TOD) signs should be moved during the off- peak tourist season, if possible.
- **Miscellaneous:** nesting seasons of birds that nest on bridges, trout migration, etc.

The estimated working days for construction should also be reviewed and the letting date should be confirmed. Lettings usually occur once a month. This is the end of Activity 5340. Enter the completion date in Clarity.

## 17. PRELIMINARY RIGHT-OF-WAY PLAN REVIEW (ACTIVITY 5345)

At this stage, right-of-way design is on the critical path. In Activity 5345, the designer should review the Preliminary Right-of-Way plans (See Chapter Fifteen: Right-of-Way, Section 2.D, of this manual). Once the roadway designer has received and reviewed the plans, the roadway designer holds a Preliminary R.O.W. plan review meeting and invites those shown in **EXHIBIT 'Q'** of the DPO, (Ref. 2.1) to discuss design of the preliminary right-of-way. **Right-of-Way Design** provides a copy of the Preliminary Right-of-Way plans to the **Roadway Design Division**. Receipt of these plans marks the end of Activity 5345. Enter the completion date in Clarity.

### 17.A Removal Items and Notes

Items which are to be removed from a tract, such as a well or a sign base, should be noted on either the plan-in-hand field inspection or during the appraisal process. Removal notes for these items will be added to the final design plans up to the time of the project turn-in to **PS&E** (approximately three months prior to the project letting). The removal should be handled as a contract item, with a special provision addressing the removal. The **Right-of-Way Design Section** should provide the roadway designer with a list of the removal items that will appear on the Right-of-Way Certificate during the Review Appraisal Process. There should be no plan changes or revisions for removal items discovered after the submittal of the final plans package; these items should be handled by the **District** with a change order and should be recorded on the as-built plans, if necessary.

## 18. DESIGN PLANS TO UTILITIES UNIT (ACTIVITY 5600)

At this stage of the project, the design is complete except for any changes from right-of-way negotiations and any unforeseen utility changes. **Right-of-Way Design** will send Appraisal Right-of-Way plans to the **Roadway Design Division** for review. The designer should transmit a set of the most recent reproducible plans to the **Utilities Unit** for them to distribute the plans to affected utilities. Contact the **Utilities Coordinator** to discuss the project further and to check for any other utility conflicts. Enter the completion date in Clarity.

## 19. INFORMATION MEETING PRIOR TO APPRAISAL AND ACQUISITION (ACTIVITY 5314)

If information meetings prior to appraisal and acquisition are held, the designer should attend along with the **Roadway Design Unit Head**, the **District Engineer**, and sometimes the **Construction Project Manager** and **Appraisers** from the **R.O.W. Division**. These meetings will use Appraisal Right-of-Way plans, (See Chapter Fifteen: Right-of-Way, Section 2.E, of this manual). The **Roadway Design Division** handles the arrangements for these information meetings, (See Section 12.C of this chapter for further information).

Make any required changes as a result of the appraisal and negotiations. Be sure that all parties, such as the **Utility Coordinator**, are notified of changes.

## 20. CHANGES TO FINAL DESIGN (ACTIVITY 5355/5357)

The final design (Activity 5355/5357) begins with a review of the design checklist (**EXHIBIT 'B'** of the DPO, Ref. 2.1) for any uncompleted tasks. This is the beginning of the final compilation of all of the information for the PS&E package. It also includes pre-appraisal meetings, if the **Chief Appraiser**, with input from the roadway designer, deems them necessary.

### 20.A Check on Other Agreements

The designer must also check on the status of all required permits and agreements so that all necessary documentation will be completed. Waterway permits, railroad agreements, status of utilities forms (that document all utilities negotiations have been settled and plans for relocation prior to construction are complete), county agreements, **Natural Resource District (NRD)** agreements, Irrigation District negotiations, etc. should all be obtained.

The city utility conflicts cost estimates and plans (if required) should be obtained. The cost estimates are required for the financial portion of the covenant agreement and should include the percentage of betterment/non-betterment work. As long as the work is non-betterment, **NDOT** pays the cost of relocation.

Ordinarily, the city will provide its own plans for utility relocation, especially for sanitary sewers. The city utility rehabilitation plans may or may not be included in the **NDOT** project. In some cases, the city work is completed prior to **NDOT** construction. In other cases, particularly in smaller cities, the utility rehabilitation may be incorporated into **NDOT** plans. A meeting should be held during this stage between the designer and city-owned utilities to discuss relocation/rehabilitation. Items to be discussed include such things as scheduling so the city can phase its work, betterment/non-betterment, etc. Enter the completion date in Clarity.



## 21. FINAL RELINQUISHMENT AGREEMENT (FRA)

The **Materials and Research Division** provides the covenant relinquishment agreements (CRA) for the final relinquishment agreement (FRA). The designer should review the CRA prior to preparing information for the FRA. The exact limits of the relinquished segment are included in the FRA along with a location map exhibit from the **Roadway Design Plans Development Unit**, and a resolution and petition form (See EXHIBIT 2.4).

The designer should review the completed FRA location map exhibit with his/her supervisor, and then send all the information to the **Materials and Research Division**. The designer should review the draft FRA and then return it to the **Materials and Research Division** for processing. For further information on relinquishments see Section 10 of this chapter; Chapter Fifteen: Right-of-Way, Section 7.D, of this manual; and The Department of Transportation Operating Instruction 60-13, "Relinquishment of Roads from the Highway System" (Appendix B, "Selected NDOT Operating Instructions", of this manual).

SEE THE DRAFT

### Resolution and Petition

WHEREAS, the Nebraska Department of Transportation of the State of Nebraska, has notified the City of \_\_\_\_\_, Nebraska, of its intention to relinquish a portion of State Highway No. \_\_\_\_\_.

NOW THEREFORE, BE IT RESOLVED by the City of \_\_\_\_\_, Nebraska that said City herewith petitions for relinquishment of said portion of said State Highway No. \_\_\_\_\_ located within the Corporate Limits of said City, and which the Department of Transportation intends to relinquish pursuant to Statute Nos. 39-1314-15 of Revised Statutes of Nebraska (1988).

AND BE IT FURTHER RESOLVED, that the Department of Transportation be notified of the desire of said City of \_\_\_\_\_ to maintain said portions of State Highway No. \_\_\_\_\_, by transmitting a copy of this Resolution to said Department.

Passed and approved this \_\_\_\_\_ day of \_\_\_\_\_, 20\_\_.

By \_\_\_\_\_

Title \_\_\_\_\_

ATTEST:

\_\_\_\_\_  
City Clerk

## 22. PREPARATION OF FINAL PLANS PACKAGE/FINAL PLAN REVIEW FOR PS&E (ACTIVITY 5369/5368)

This activity essentially is the assembly of the final plans package. Plans submitted to **PS&E** shall have all plan corrections completed by the **Roadway Design Plans Development Unit** prior to submission. The designer should complete any outstanding miscellaneous design plans, (i.e., guardrail). The design checklist (**EXHIBIT 'B'** of the DPO, Ref. 2.1) should once again be checked.

Computations should be received from the **Materials and Research Division** and typical sections should be finalized. The computation sheets for each pay item should be completed, checked and rechecked, preferably by someone other than the one who did the original computations. Design details should be completed.

For further information, see Chapter Eleven: Highway Plans Assembly, Section 4, of this manual.

### 22.A Assemble Project Data

The designer should accumulate all project data including but not limited to the following:

- Right-of-way certificate, (See Chapter Fifteen: Right-of-Way, Section 6, of this manual).
- Status of utilities.
- Seeding and erosion control special provisions and special plans.
- Agreements with city, county, Irrigation District, utilities, railroads, NRD, sanitary improvement districts (in urban areas), (See Section 10 of this chapter and Chapter Thirteen: Planning and Project Development, Section 6.A, of this manual).
- Final Relinquishment Agreement, (See Section 21 of this chapter).
- Waterway permits, e.g., 404 permit, nationwide permit (NWP), channel relocation, floodplain certification, etc., (See Chapter Thirteen: Planning and Project Development, Section 5, of this manual).

The total design package including graphical presentation of plans, complete notes and details should be reviewed so that nothing has been forgotten. Again, use the design checklist (**EXHIBIT 'B'** of the DPO, Ref. 2.1). Any special provisions that have been compiled should be elaborated on and/or finalized. The soils report should be reviewed and checked for the need for special provisions such as a compaction requirement sheet.

Receive plans from:

- **Bridge Division.**
- **Traffic Engineering Division.**
- **ITS/Lighting Unit.**
- **Materials and Research Division.**
- **Right-of-Way Design** (Ownership plans).
- Others , e.g., **City, County, Utilities, NRD**, etc.

Computer books for the **District Engineer** should be prepared including slope stake book, blue top book and paving grades.

## **22.B**      **Check Earthwork and Notes**

Use the earthwork checklist (**EXHIBIT 'N'** of the DPO, Ref. 2.1) to review earthwork information. Verify that a utility note is included that shows the contractor is responsible for notifying utilities prior to digging.

Note that in some cases shoulder construction notes specify separate pay items by station. Check for:

- Earthwork balance points and quantities.
- Covercrop seeding note: on expressway projects where traffic remains on the existing roadway and then switches to new travel lanes, some areas may need seeding more than once.
- Shoulder construction notes.
- Superelevation notes.
- Scale stamp on cross-sections: horizontal and vertical scales will differ.
- Grade alignment at project ends and crossings for detours and temporary roads.
- Special provisions, e.g., surcharge over winter.
- Sketches for construction items, e.g., typicals for dikes, guardrail, driveways on Summary of Quantity sheets, etc.

Be sure that project stationing is shown on plans, typical sheets and project length sheet.

The final task of activity 5369 is the completion of a PS&E Required Sheet (NDOT Form 280). This form is a legal size sheet that should be completed to accompany the PS&E package. Enter the completion date in Clarity.

## **22.C**      **Checking Plans for Conflicts**

The designer is responsible for checking plans generated by other divisions for conflicts with the Roadway Design plans. For example: Have light poles or overhead traffic signs been installed in front of the guardrail? Are there conflicts with existing or proposed utilities and the storm sewer design?

## **22.D      Final Plan Review For PS&E**

Activity 5369/5368 includes the final check of all construction notes with the computation sheets and includes a review of the PS&E plans with the **Roadway Design Unit Head**. The design checklist (**EXHIBIT 'B'** of the DPO, Ref. 2.1) should be used.

The city financial agreement should be prepared and sent to the **District Engineer** to obtain signatures. See DOT-OI 45-5, "Agreements", (Appendix B, "Selected NDOT Operating Instructions", of this manual) for further information regarding agreements.

The final task for this activity is the submittal of PS&E plans to the **PS&E Section** in the **Construction Division**. Enter the completion date in Clarity when the project is given to **PS&E**.

**PS&E** checks the plans and quantities and informs the designer of any required plan changes. When the corrected plans are returned to **PS&E**, the CADD files are locked to prevent unauthorized changes to the contract plans. The roadway designer shall contact the **Roadway Design Plans Manager** to unlock the CADD files prior to making plan revisions, (See Section 23.A of this chapter and Chapter Eleven: Highway Plans Assembly, Section 7, of this manual for further information).

During the period after a project has been advertised for letting until it has been let to contract, all questions from outside the **Nebraska Department of Transportation** (i.e. contractors or suppliers) regarding the project and plans shall be referred to the **Highway Construction Scheduling Manager** in the **Construction Division**.

## **23.            POST LETTING SUPPORT AND PLAN REVISION (ACTIVITY 5375/5376)**

Activity 5375/5376 covers all post letting Design functions including the Pre-Construction Conference, construction review of any type, Plan Revisions, and the Post-Construction Conference. The project is not complete until construction is finished and **NDOT** has accepted the finished product.

### **23.A            Changes to the Design Plans**

Any changes to the design plans which occur after the project has been let to contract will necessitate either a plan revision or a change order. Any changes which require engineering should be handled as plan revisions. Any changes which are adjustments to the existing plans (such as changing the culvert placement within the same drainage way) can be handled as change-orders and should be shown on the as-built plan set.

### 23.A.1 Plan Revisions

The **Roadway Design Division** may be involved in plan revisions at any time during the construction of a project. If the plans for a project are to be changed after the project has been submitted to **PS&E** but before it is advertised for letting, **PS&E** will send the plans back to the **Roadway Design Division** for the changes to be made. The changes are not considered to be a plan revision at this stage of the project. If, however, the project has been advertised and changes are necessary, the plan revision procedures should be used as outlined in Chapter Eleven: Highway Plans Assembly, Section 7.

Notice should be given when plan revisions are anticipated. Any division that is involved in a project needs to be made aware of any changes or revisions that another division may make to the plans. For example, if a roadway project requires a bridge revision, the **Bridge Division** must inform the **Roadway Design Division**, **Right-of-Way**, **Traffic**, and any other involved divisions that they are initiating a revision to the plans.

For plan revisions initiated in the **Roadway Design Division**, the roadway designer should send a notification, (which can be an e-mail), detailing the proposed revision to the **Assistant Design Engineer** and the **Roadway Design Unit Head**. The notification should include the following information:

- Project Name & Number.
- Control Number.
- Revision Number.
- Tract Numbers affected.
- A brief description of the changes.
- An approximate completion date.

If the **Assistant Design Engineer** approves of the proposed revision, the **Roadway Design Unit Head** will forward the notification to the following:

- **District Engineer**
- **District Construction Engineer**
- **Roadway Design Plans Manager** (responsible for unlocking CADD files)
- **Construction Engineer**
- **District Project Manager**
- **Bridge** (if applicable)
- **Traffic**
- **ROW Design Engineer**
- **ADE** for the **Utilities Unit**
- **CADD Applications Engineer**
- **FHWA** (on federal oversight projects only)
- Any other affected Divisions/Sections

*Plans will not be revised without written authorization from the **Assistant Design Engineer**. All federal oversight projects shall have **FHWA** approval to proceed **before** the plan revisions are made, (the **Design Unit Head** is responsible for informing the **Roadway Design Plans Manager** when **FHWA** approval has been received).*

All plan revisions *must* be signed and sealed by a P.E., (See Chapter Eleven: Highway Plans Assembly, Section 8, of this manual). The **Roadway Design Unit Head** and **Assistant Design Engineer** must be kept informed of all changes to the plans, regardless of whether the changes are made in the **Roadway Design Division** or in the **District**; it is the **Assistant Design Engineer's** decision whether a plan change can be handled with a change order or is a plan revision requiring a signed and sealed document. If the **District Engineer** or the **District Construction Engineer** is willing to seal and sign plan revisions in the field that is acceptable, as long as the **Roadway Design Unit Head** and **Assistant Design Engineer** are consulted about the design of the proposed revisions before they are finalized. If the **Roadway Design Division** authorizes or transmits a plan revision to the **District** via fax, phone, or e-mail, the responsible **Roadway Design Division Engineer's** seal and signature will be affixed to the transmittal, which will then be scanned and sent to the **District**.

#### 24. ARCHIVING THE PROJECT FILE

After the project is completed, the designer is responsible for archiving the project file in the vault. Archive instructions (transmitted by the vault to the designer) should be used to properly prepare the file for archives. This usually occurs two years after final computations are completed.

**25. REFERENCES**

- 2.1 Nebraska Department of Transportation, Design Process Outline, Current Edition (<https://dot.nebraska.gov/business-center/design-consultant/>)
- 2.2 Nebraska Department of Transportation, Drainage Design and Erosion Control Manual, Current Edition
- 2.3 Nebraska Department of Transportation, Access Control Policy to the State Highway System, Current Edition. (<https://dot.nebraska.gov/media/v45nhanu/access-control-policy.pdf>)

SEE THE DPO



The information contained in Chapter Three: Roadway Alignment dated May 2022, has been updated to reflect the January 2023 Errata. The errata incorporates DES 22-02: "Maximum Allowable Deflection on a Horizontal Alignment Without a Curve", which was approved by the Nebraska Division of the FHWA on July 20, 2022, addresses errors, changes in procedure, changes in NDOT department titles, changes in other Roadway Design Manual chapters and other reference material citations occurring since the latest publication of this chapter.

Chapter Three presents guidance for the design of New and Reconstructed projects; design guidance for 3R projects is provided in Chapter Seventeen.

## Chapter Three Roadway Alignment

This chapter presents the **Nebraska Department of Transportation (NDOT)** policies and criteria for the design of roadway horizontal and vertical alignments, generally based on passenger car performance unless otherwise stated. The **American Association of State Highway and Transportation Officials (AASHTO's)** A Policy on Geometric Design of Highways and Streets (the *Green Book*) (Ref. 3.1) provides a more comprehensive description of the alignment considerations presented in this chapter and should be referred to for further details.

### 1. SIGHT DISTANCE

A driver must be able to see an object on the roadway ahead with sufficient time and distance to select and complete the appropriate action (avoid the object or stop). This is referred to as sight distance. The different types of sight distance include:

- Decision sight distance
- Stopping sight distance
- Passing sight distance
- Sight distance on horizontal curves
- Intersection sight distance

For additional information see Chapters 3 and 9 of the *Green Book* (Ref. 3.1).

## 2. HORIZONTAL ALIGNMENT DESIGN

Major considerations in horizontal alignment include:

- Design speed
- Topography
- The environment
- Economics

The **Project Development Division (PDD)** will usually recommend an approximate horizontal alignment for the project during the engineering review. It is the responsibility of the roadway designer to check the alignment and to verify its compliance with **NDOT's** design guidance (See Chapter One: Roadway Design Standards of this manual).

Environmental considerations and impacts are a vital component of the design process; the roadway designer shall coordinate with the **Environmental Section** in **PDD** in the development of, and in any subsequent alteration to, the horizontal alignment. The horizontal alignment should not be changed during the Plan Details Phase (Clarity Activity 5500).

### 2.A Maximum Allowable Deflection on a Horizontal Alignment Without a Curve

As a general guide, any change in direction of the horizontal alignment with a deflection angle  $\geq 0^{\circ}30'$  on high-speed roadways ( $\geq 50$  mph) or  $\geq 1^{\circ}$  on low-speed ( $\leq 45$  mph) and urban roadways will require a horizontal curve. Section 3.3.13, "General Controls for Horizontal Alignment", in Chapter 3 of the *Green Book* (Ref. 3.1) contains the following guidance:

- For small deflection angles, curves should be sufficiently long to avoid the appearance of a kink. Curves should be at least 500 feet long for a central angle of  $5^{\circ}$ , and the minimum length should be increased 100 feet for each  $1^{\circ}$  decrease in the central angle. The minimum length for horizontal curves on main highways, ( $L_{c \text{ min}}$ ) should be 15 times the design speed expressed in mph ( $V$ ), or  $L_{c \text{ min}} = 15V$ . On high-speed controlled access facilities that use flat curvature for aesthetic reasons, the desirable minimum length for curves ( $L_{c \text{ des}}$ ) should be double the minimum length described above, or  $L_{c \text{ des}} = 30V$ .

For 3R projects, an improvement to the horizontal alignment may be considered if there is a relevant crash history. See Chapter Seventeen: Resurfacing, Restoration and Rehabilitation (3R) Projects, Section 3.B, of this manual for additional information.

### 2.B Horizontal Curvature

**NDOT** designs and designates horizontal curves based on the radius of the curve (for conversion from/to degree of curvature see Appendix G, "Degree of Curvature"). The use of the minimum horizontal curve radius should be avoided unless economically or environmentally necessary.

#### 2.B.1 Simple Curves

**NDOT** uses arc definition for curve computation. Usually the PI station, the intersection angle ( $I$ ), and the circular curve radius ( $R$ ) are established; the remaining curve data must be computed (See EXHIBIT 3.1).

### 2.B.2 Reverse Curves

A reverse curve consists of two curves on opposite sides of a common tangent with a relatively short tangent length between the curves. The tangent length between the curves is usually dictated by superelevation requirements for each curve (See Section 2.C of this chapter).

### 2.B.3 Compound Curves

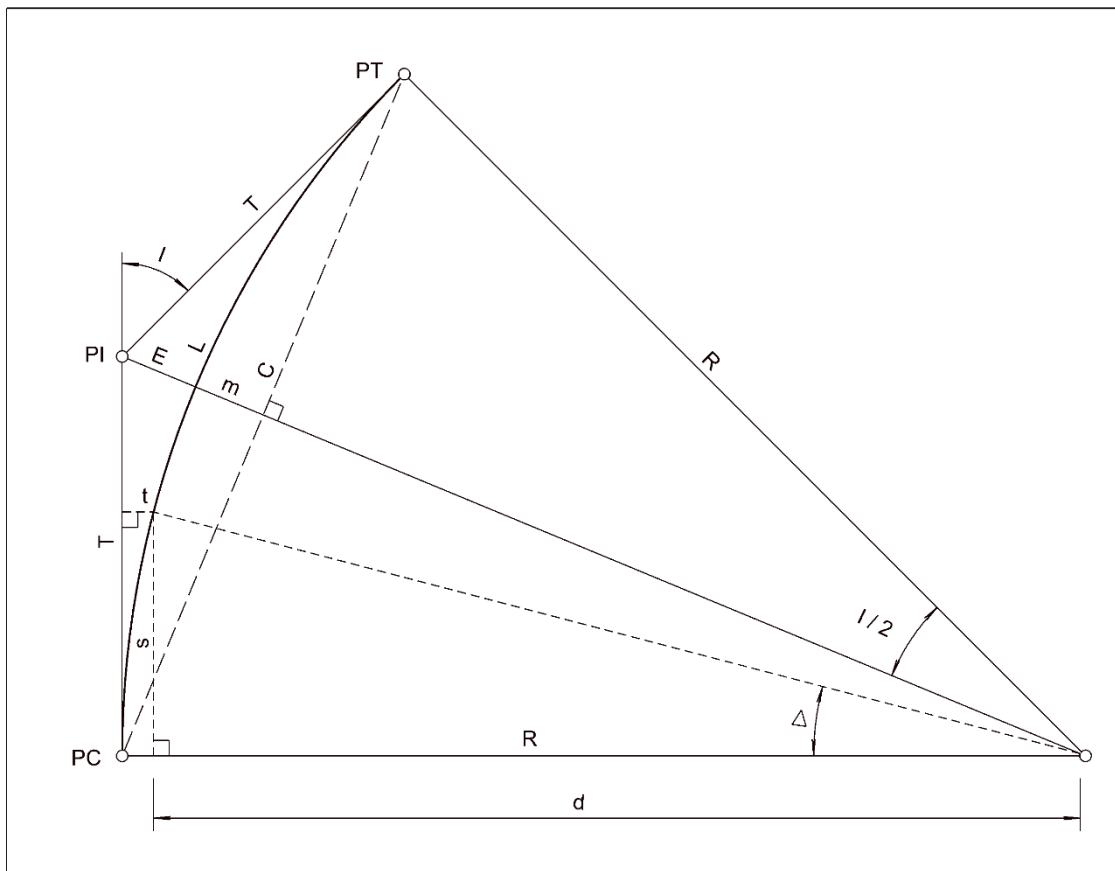
A compound curve consists of two consecutive curves of differing radii deflecting in the same direction with no tangent length between the curves. When field conditions dictate that a compound curve be utilized (e.g. for locations where an obstruction cannot be mitigated otherwise) the ratio of the flatter radius to the sharper radius should not exceed 1.5:1.

### 2.B.4 Broken Back Curves

A broken back curve consists of two consecutive curves deflecting in the same direction joined by a short tangent section.

### 2.B.5 Spiral Transition Curves

A spiral curve provides a transition between a tangent roadway section and a circular curve. The degree of curvature on a spiral gradually varies from zero at the tangent end to the degree of circular arc at the curve end. While **NDOT** sees only marginal benefits in the design of spiraled transition curves for new roadway alignments in general, spiral transition circular curves are preferred on Interstate ramps due to the higher percentage of truck traffic. For additional information see Chapter Five: Interstates, Grade Separations, and Interchanges, Section 3.C of this manual and Section 3.3.8.3, "Spiral Curve Transitions", in Chapter 3 of the *Green Book* (Ref. 3.1).



Curve Symbols and Abbreviations	Curve Formulas
<p>I Intersection angle of the curve                      C Length of long chord from PC to PT                      D Degree of curve                      E External distance (PI to mid-point of curve)                      L Length of curve from PC to PT                      m Middle ordinate (distance from the mid-point of the curve to the mid-point of the long chord)                      PC Point of curvature (beginning of curve)                      PI Point of intersection of tangents                      PT Point of tangency (end of curve)                      R Radius of curve                      T Tangent distance (distance from PC to PI, distance from PI to PT)                      s Distance along the tangent to any point on curve                      t Offset from the tangent to any point on curve                      Δ Intersection angle to any point on curve</p>	<p><math>I = 2 \sin^{-1}(L/2R) = (L/R) \times (180/\pi)</math>  <math>C = 2R \sin (I/2)</math> (<i>I</i> in degrees)  <math>D = 5729.57795/R</math>  <math>E = [\sqrt{(R^2 + T^2)}] - R</math>  <math>L = RI</math> (<i>I</i> in radians)  <math>= 2\pi R (I/360)</math> (<i>I</i> in degrees)  <math>m = R(1 - \cos(I/2))</math> (<i>I</i> in degrees)  <math>R = 5729.57795/D</math>  <math>= (4m^2 + C^2)/8</math>  <math>s = R \sin \Delta</math>  <math>d = R \cos \Delta</math>  <math>t = R - d</math>  <math>\pi = 3.141592653</math>  <math>PC \text{ Sta.} = PI \text{ Sta.} - T</math>  <math>PT \text{ Sta.} = PC \text{ Sta.} + L</math></p>

Exhibit 3.1 Elements of a Simple Curve

**2.C Superelevation**

The minimum horizontal curve radius is determined by the design speed of the facility (V) and by the maximum allowable superelevation rate ( $e_{max}$ ). Selection of a maximum superelevation rate depends on several factors, including:

- Design speed
- Location
- Climatic conditions
- Roadside conditions
- Future or ultimate development
- Roadway characteristics
- Facility type
- Driver expectations

EXHIBIT 3.2 summarizes the superelevation rates used in Nebraska.

For rural highways and for bridge structures a desirable maximum superelevation rate of 6% (EXHIBIT 3.3c) should be used unless design constraints dictate the use of the 8% maximum superelevation rate. Bridge structures should not be constructed in the transition zones of superelevated horizontal curves. Due to prevailing snow and ice conditions, the maximum superelevation rate shall not exceed 8%. The use of the maximum superelevation rate of 8% requires **Assistant Design Engineer (ADE)** approval and a decision letter to the project file (See Chapter One: Roadway Design Standards, Section 10.C, of this manual). An 8% superelevation rate should be designed in accordance with Section 3.3, “Horizontal Alignment”, in Chapter 3 of the *Green Book* (Ref. 3.1).

Location	Max. Allowable Superelevation	Desirable Max. Superelevation
Rural Roadways	8%* (See Ref. 3.1, Chapter 3)	6% ( <u>EXHIBITS 3.3c, 3.4c &amp; 3.5c</u> )
Bridges	8%* (See Ref. 3.1, Chapter 3)	6% ( <u>EXHIBITS 3.3c, 3.4c &amp; 3.5c</u> )
High-Speed Urban Roadways V ≥ 50 mph	6% ( <u>EXHIBIT 3.3c</u> )	6% ( <u>EXHIBIT 3.3c</u> )
Desirable Design, Low-Speed Urban Roadways V ≤ 45 mph	4% ( <u>EXHIBIT 3.3d</u> )	4% ( <u>EXHIBITS 3.3d &amp; 3.6c</u> )
Minimum Design, Low-Speed Urban Roadways V ≤ 45 mph	4% (Ref. 3.1, <b>TABLE 3-13 **</b> )	4% (Ref. 3.1, <b>TABLE 3-13 **</b> )

\* Requires **ADE** approval and a decision letter to the project file.

\*\* The use of **TABLE 3-13** (Ref. 3.1) requires **ADE** approval and a decision letter to the project file (See Chapter One: Roadway Design Standards, Section 10.C, of this manual).

**Exhibit 3.2 Superelevation Rates**

### 2.C.1 Transition Lengths

- **Tangent Runout** - The distance required to transition the roadway from a normal crown section to a section with the adverse crown removed, or vice versa.
- **Superelevation Runoff Length ( $L_r$ )** - The distance required to transition the roadway from a section with the adverse crown removed to a fully superelevated section, or vice versa.
- **Superelevation Transition Length** - The sum of the tangent runout and the superelevation runoff ( $L_r$ ).

EXHIBITS 3.3b, 3.4b, 3.5b, and 3.6b illustrate the relationship between superelevation transition, tangent runout, and superelevation runoff length for two-lane roadways, for dual lane highways with crowned surface, for dual lane highways with tangent surface, and for dual lane highways with raised medians.

The minimum superelevation runoff lengths shown in EXHIBITS 3.3c AND 3.3d were calculated for two-lane and four-lane undivided roadways, see **TABLE 3-15** in the *Green Book* (Ref. 3.1) to determine the minimum superelevation runoff lengths for multilane undivided roadways.

For simple curves 50 to 80% of the superelevation runoff length ( $L_r$ ) should be placed on the tangent prior to the curve (the majority of agencies use 67%). See Section 3.3.8, "Transition Design Controls", in Chapter 3 of the *Green Book* (Ref. 3.1) for additional information.

To facilitate pavement drainage, a minimum profile grade of 1.5% shall be maintained through the area where the adverse crown has been removed. A flatter profile grade, down to and including a grade of 0.5%, may be used with **Unit Head** approval.

### 2.C.2 Axis of Rotation

The axis of rotation is the point on the roadway cross-section about which the roadway is rotated to attain the desired superelevation through the horizontal curve. EXHIBITS 3.3a, 3.4a, 3.5a, and 3.6a illustrate **NDOT** standard procedures for the application of the axis of rotation in superelevation development for two-lane highway sections and for four-lane divided highway sections. See Section 3.3.8, "Transition Design Controls", in Chapter 3 of the *Green Book* (Ref. 3.1) for methods of attaining superelevation where **NDOT** procedures do not apply.

For two-lane roadways the superelevation should be rotated about the highway centerline, which is normally the profile grade line (See EXHIBIT 3.3a). This method minimizes the elevation differential between the pavement edges and their normal profiles. Rotation about the inside or outside axis of the roadway is acceptable when required to satisfy field conditions, such as surface drainage on a curbed facility.

For multi-lane facilities with crowned surfaces and depressed medians of 54 feet or less in width the profile grade point should be about the inside (median) edge of the 12 foot inside lane of each roadway (See EXHIBIT 3.4a). The axis of rotation for the outer roadway should be located at the centerline of the lanes until the superelevation transition attains reverse crown, at which point the axis of rotation will shift to the inside edge of the 12 foot inside lane. The axis of rotation for the inner roadway should be located at the inside edge of the 12 foot inside lane of the roadway, the same location as the profile grade point. This method results in the maintenance of approximately

a two-foot median ditch depth. When the median width is greater than 54 feet the axis of rotation and the profile grade point may be the centerline of the individual lanes.

For multi-lane facilities with tangent surfaces and depressed medians of 54 feet or less in width the axis of rotation should be about the profile grade line, which is the inside (median) edge of the 12 foot inside lane of each roadway. This method maintains the median in a horizontal plane throughout the curve (See [EXHIBIT 3.5a](#)). When the median width is greater than 54 feet the axis of rotation and the profile grade point may be the centerline of the individual lanes.

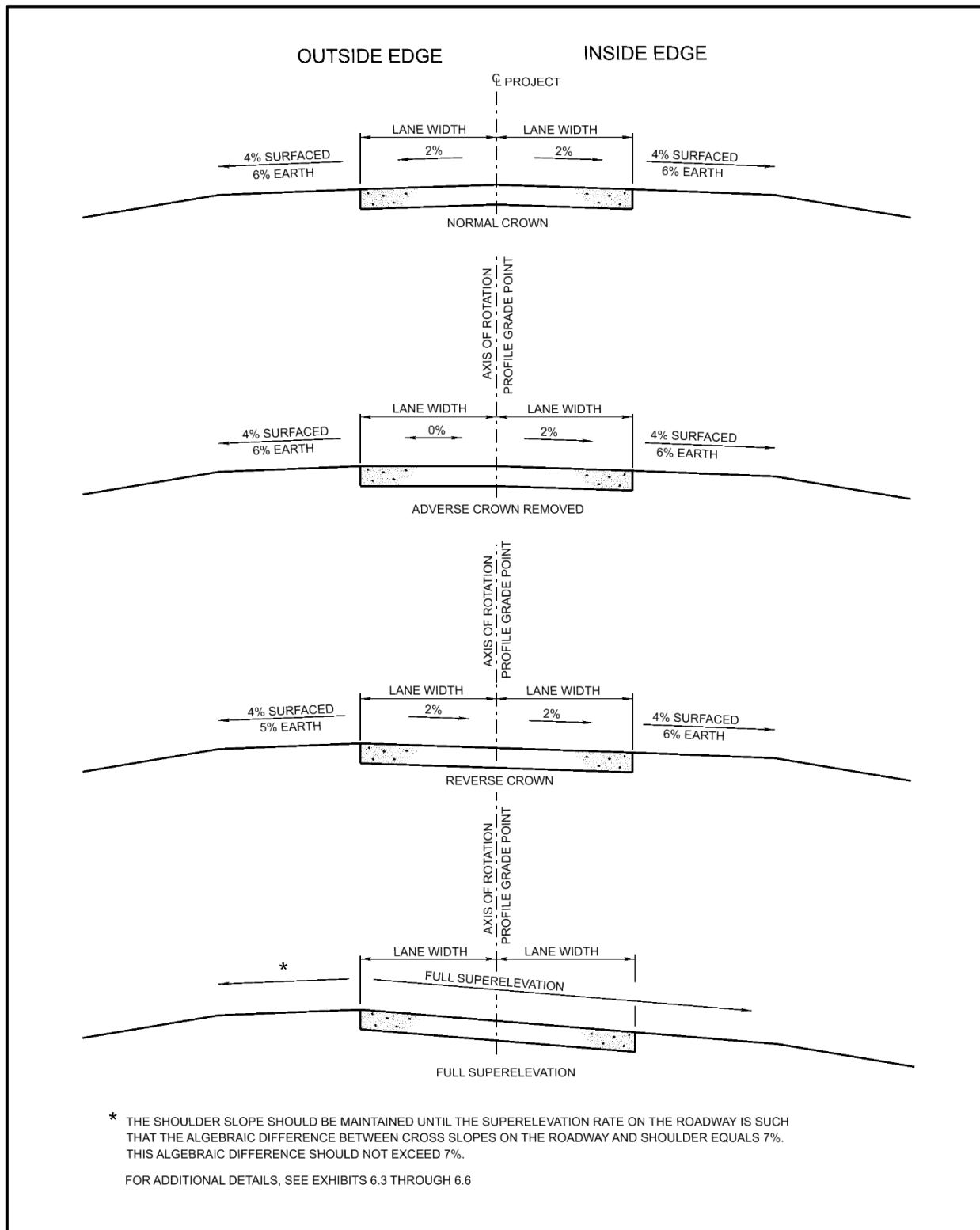
For multi-lane facilities with raised medians, the axis of rotation and the profile grade point should be located at the inside edge of the 12 foot inside lane (See [EXHIBIT 3.6a](#)).

### **2.C.3 Smoothing of Pavement Edge Profile**

Angular breaks in the vertical profile of the pavement edge through the superelevation transition length should be rounded in Roadway Design Details (Clarity Task 5508). For general appearance, **NDOT** softens these sharp angular breaks by the insertion of short vertical curves along the pavement edge. As an approximate guide, the minimum vertical curve length in feet can be set as numerically equal to the design speed in miles per hour; greater lengths should be used where practicable.

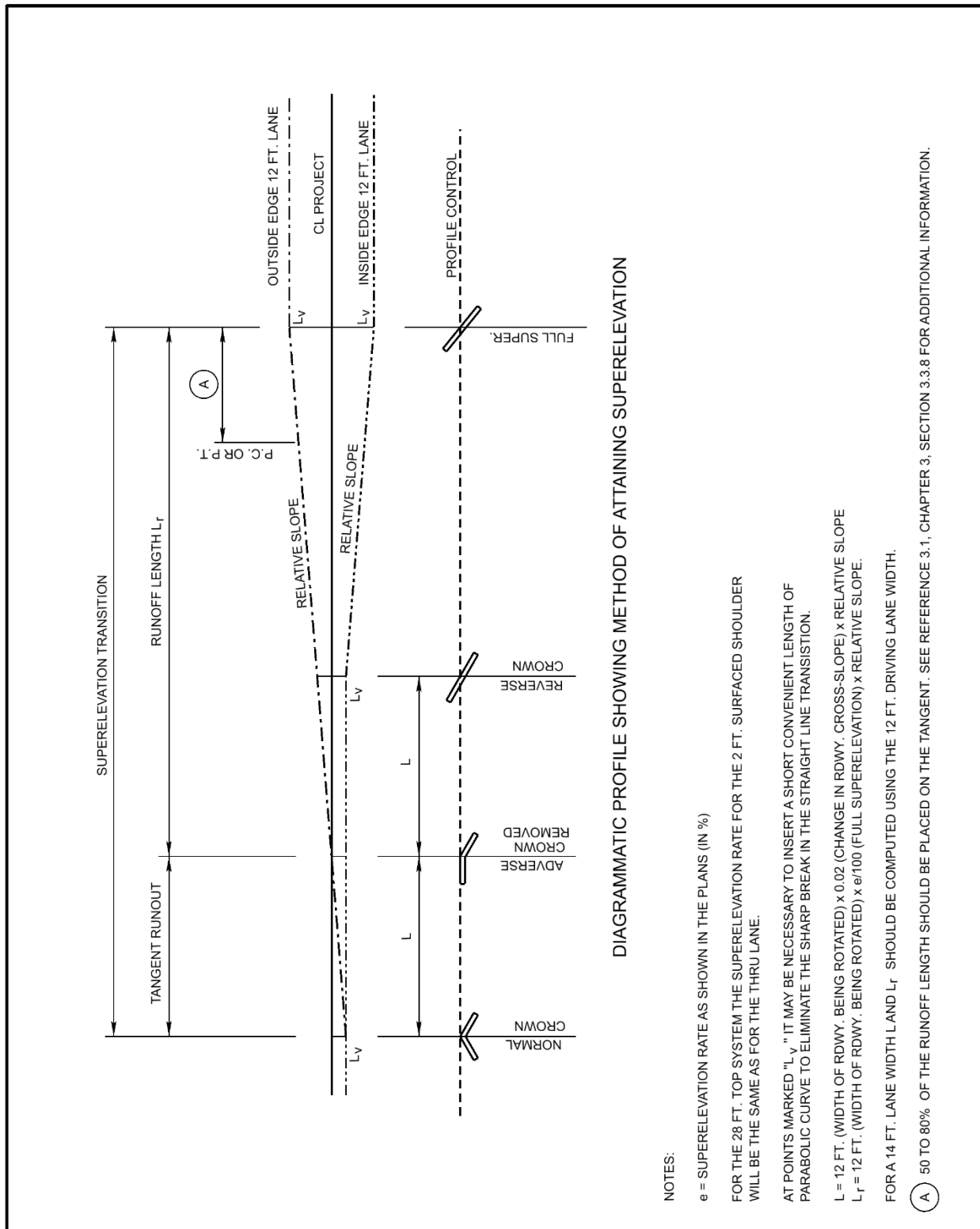
### **2.D Pavement Widening on Curves (Off-tracking)**

Pavement widening may be warranted if a vehicle or truck occupies a greater width due to the rear wheels tracking inside of the front wheels while rounding curves. See Section 3.3.10, "Traveled-Way Widening on Horizontal Curves", in Chapter 3 of the *Green Book* (Ref. 3.1) for additional information.



**Exhibit 3.3a Superelevation Data for Crowned Highways  
 Typical Sections**





**Exhibit 3.3b Super-elevation Data for Crowned Highways Diagrammatic Profile**

Radius of Curve (ft.)	V=50 mph			V=55 mph			V=60 mph			V=65 mph			V=70 mph			V=75 mph			V=80 mph			
	e (%)	Maximum Relative Slope		e (%)	Maximum Relative Slope		e (%)	Maximum Relative Slope		e (%)	Maximum Relative Slope		e (%)	Maximum Relative Slope		e (%)	Maximum Relative Slope		e (%)	Maximum Relative Slope		
		L (ft.)	L <sub>r</sub> (ft.)		L (ft.)	L <sub>r</sub> (ft.)		L (ft.)	L <sub>r</sub> (ft.)		L (ft.)	L <sub>r</sub> (ft.)		L (ft.)	L <sub>r</sub> (ft.)		L (ft.)	L <sub>r</sub> (ft.)		L (ft.)	L <sub>r</sub> (ft.)	L (ft.)
23000	NC	0	0	NC	0	0	NC	0	0	NC	0	0	NC	0	0	NC	0	0	NC	0	0	
20000	NC	0	0	NC	0	0	NC	0	0	NC	0	0	NC	0	0	NC	0	0	NC	0	0	
17000	NC	0	0	NC	0	0	NC	0	0	NC	0	0	NC	0	0	NC	0	0	NC	0	0	
14000	NC	0	0	NC	0	0	NC	0	0	NC	0	0	NC	0	0	NC	0	0	NC	0	0	
12000	NC	0	0	NC	0	0	NC	0	0	NC	0	0	NC	0	0	NC	0	0	NC	0	0	
10000	NC	0	0	NC	0	0	2.0	53	53	2.0	56	56	2.0	56	56	2.1	60	63	2.1	69	72	
8000	NC	0	0	2.0	51	51	2.0	53	53	2.3	56	64	2.5	60	75	2.8	63	88	3.1	69	106	
6000	2.0	48	48	2.2	51	56	2.6	53	69	2.9	56	81	3.2	60	96	3.5	63	110	4.0	69	137	
5000	2.2	48	53	2.6	51	66	3.0	53	80	3.3	56	92	3.7	60	111	4.1	63	129	4.6	69	158	
4000	2.7	48	65	3.1	51	79	3.6	53	96	4.0	56	112	4.4	60	132	4.9	63	155	5.5	69	189	
3500	3.0	48	72	3.5	51	89	3.9	53	104	4.4	56	123	4.9	60	147	5.3	63	167	5.9	69	202	
3000	3.4	48	82	3.8	51	97	4.3	53	115	4.8	56	134	5.4	60	162	5.7	63	180				
2500	3.8	48	91	4.3	51	110	4.8	53	128	5.3	56	148	5.8	60	174	6.0	63	189				
2000	4.3	48	103	4.9	51	125	5.4	53	144	5.8	56	162										
1800	4.6	48	110	5.1	51	130	5.6	53	149	6.0	56	167										
1600	4.9	48	118	5.4	51	138	5.8	53	155													
1400	5.2	48	125	5.7	51	146	6.0	53	160													
1200	5.5	48	132	5.9	51	151																
1000	5.9	48	142																			
900	6.0	48	144																			

**e<sub>max</sub> = 6%**

Source: Adapted from "A Policy on Geometric Design of Highways and Streets", (Reference 3.1), Eq. 3-12 thru 3-24. For additional information see Reference 3.1, Tables 3-9 & 3-16.

KEY:

- V = Assumed design speed
- e = Rate of superelevation
- L = Tangent runoff based on a 12 ft. lane
- L<sub>r</sub> = Minimum length of superelevation runoff based on a 12 ft. lane
- NC = Normal crown section

R<sub>min</sub> = 833

R<sub>min</sub> = 1060

R<sub>min</sub> = 1330

R<sub>min</sub> = 1660

R<sub>min</sub> = 2040

R<sub>min</sub> = 2500

R<sub>min</sub> = 3050

**Exhibit 3.3c Superelevation Data for Crowned Highways**  
**Values for Design Elements Related to Design Speed and Horizontal Curvature**  
**(e<sub>max</sub>=6%)**

Radius of Curve (ft.)	V=25 mph			V=30 mph			V=35 mph			V=40 mph			V=45 mph			V=50 mph		
	e (%)	Maximum Relative Slope		e (%)	Maximum Relative Slope		e (%)	Maximum Relative Slope		e (%)	Maximum Relative Slope		e (%)	Maximum Relative Slope		e (%)	Maximum Relative Slope	
		L (ft.)	L <sub>r</sub> (ft.)		L (ft.)	L <sub>r</sub> (ft.)		L (ft.)	L <sub>r</sub> (ft.)		L (ft.)	L <sub>r</sub> (ft.)		L (ft.)	L <sub>r</sub> (ft.)		L (ft.)	L <sub>r</sub> (ft.)
8000	NC	0	0	NC	0	0	NC	0	0	NC	0	0	NC	0	0	NC	0	0
6000	NC	0	0	NC	0	0	NC	0	0	NC	0	0	NC	0	0	NC	0	0
5000	NC	0	0	NC	0	0	NC	0	0	NC	0	0	NC	0	0	NC	0	0
4000	NC	0	0	NC	0	0	NC	0	0	NC	0	0	NC	0	0	NC	0	0
3500	NC	0	0	NC	0	0	NC	0	0	2.0	39	39	2.0	41	41	2.0	44	44
3000	NC	0	0	NC	0	0	NC	0	0	2.0	39	39	2.1	41	43	2.4	44	53
2500	NC	0	0	NC	0	0	NC	0	0	2.0	39	39	2.3	41	47	2.6	44	58
2000	2.0	34	34	2.0	36	36	2.3	39	45	2.6	41	54	2.8	44	62	3.2	48	77
1800	2.0	34	34	2.0	36	36	2.4	39	46	2.7	41	56	3.0	44	67	3.3	48	79
1600	2.0	34	34	2.2	36	40	2.5	39	48	2.8	41	58	3.2	44	71	3.5	48	84
1400	2.0	34	34	2.3	36	42	2.6	39	50	3.0	41	62	3.3	44	73	3.7	48	89
1200	2.1	34	36	2.4	36	44	2.8	39	54	3.2	41	66	3.6	44	80	3.9	48	94
1000	2.3	34	39	2.6	36	47	3.0	39	58	3.4	41	70	3.8	44	84	4.0	48	96
900	2.4	34	41	2.7	36	49	3.1	39	60	3.6	41	74	3.9	44	87			
800	2.4	34	41	2.8	36	51	3.3	39	64	3.7	41	76	4.0	44	89			
700	2.5	34	43	3.0	36	55	3.4	39	66	3.9	41	80						
600	2.7	34	46	3.2	36	58	3.6	39	70	4.0	41	83						
500	2.8	34	48	3.4	36	62	3.9	39	75									
450	2.9	34	50	3.5	36	64	4.0	39	77									
400	3.1	34	53	3.6	36	65	4.0	39	77									
350	3.2	34	55	3.8	36	69												
300	3.4	34	58	3.9	36	71												
250	3.6	34	62	4.0	36	73												
200	3.8	34	65															

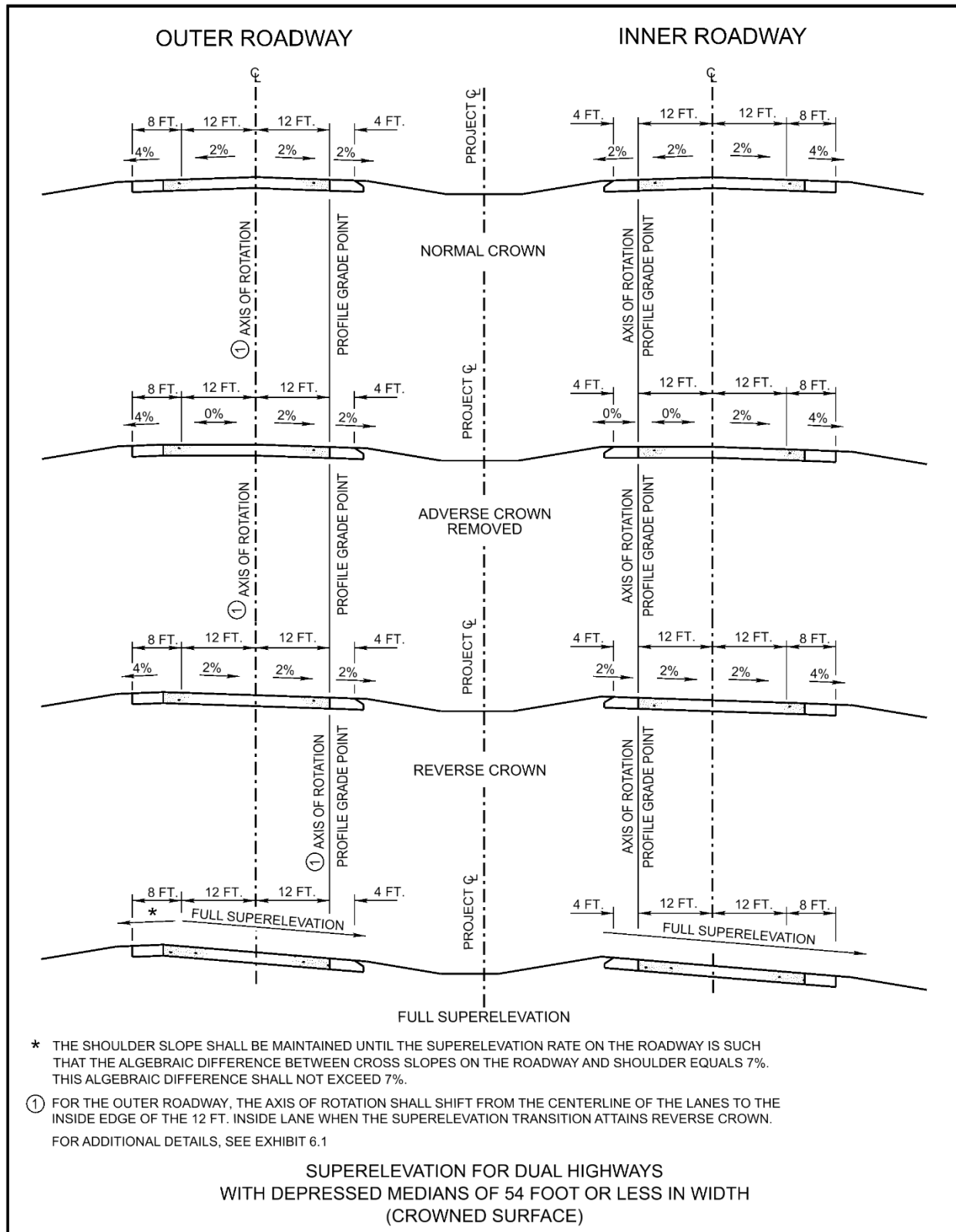
**e<sub>max</sub> = 4%**

Source: Adapted from "A Policy on Geometric Design of Highways and Streets", (Reference 3.1), Eq. 3-12 thru 3-24. For additional information see Reference 3.1, Tables 3-13 & 3-16.

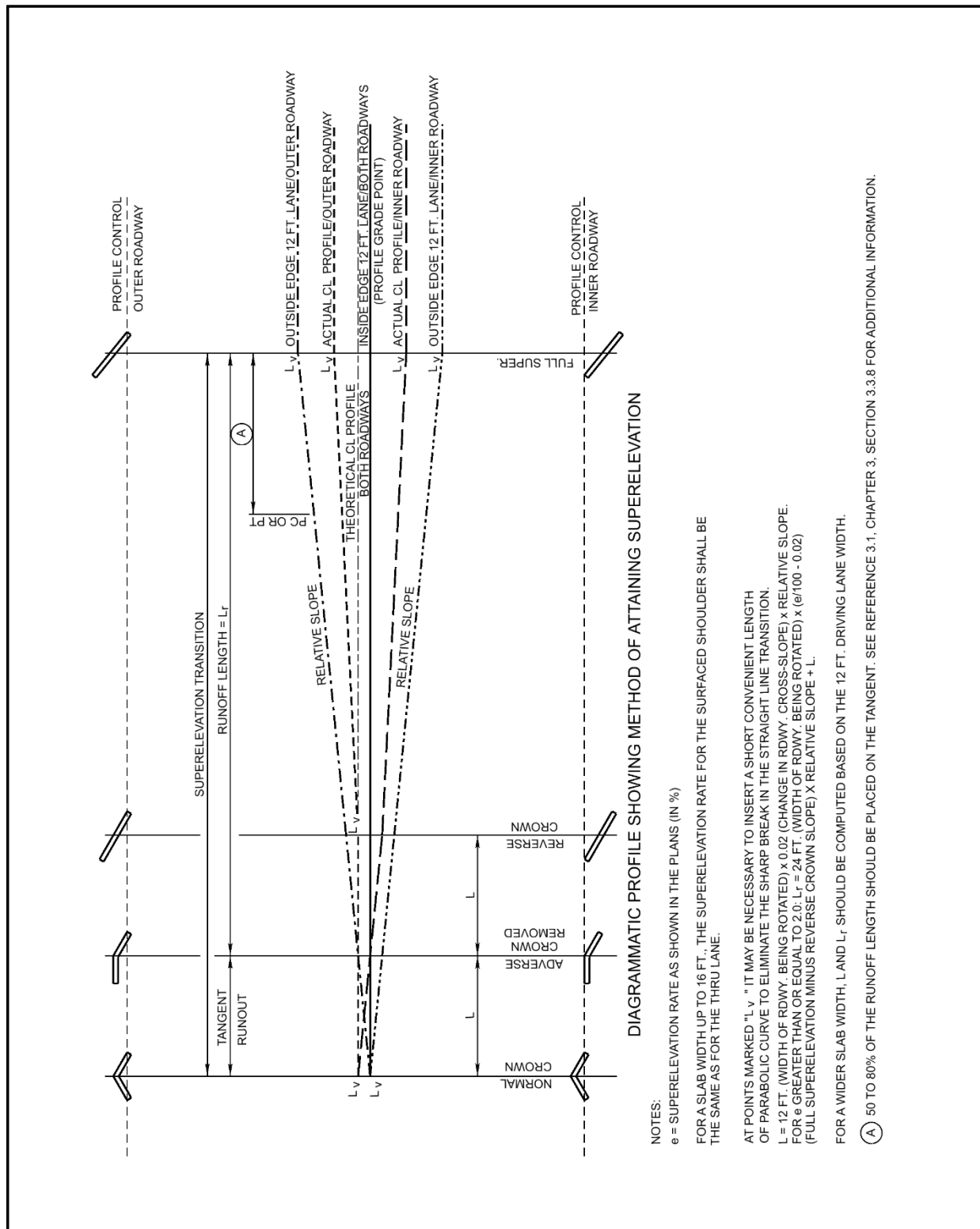
KEY:

- V = Assumed design speed
- e = Rate of superelevation
- L = Tangent runoff based on a 12 ft. lane
- L<sub>r</sub> = Minimum length of superelevation runoff based on a 12 ft. lane
- NC = Normal crown section

**Exhibit 3.3d Superelevation Data for Crowned Highways**  
**Values for Design Elements Related to Design Speed and Horizontal Curvature**  
**(e<sub>max</sub>=4%)**



**Exhibit 3.4a Superlevation Data for Dual Highways (Crowned Surface)  
 Depressed Median Width = 54 Foot or Less  
 Typical Sections**



**Exhibit 3.4b Superlevation Data for Dual Highways (Crowned Surface)  
 Depressed Median Width = 54 Foot or Less  
 Diagrammatic Profile**

Radius of Curve (ft.)	V=50 mph			V=55 mph			V=60 mph			V=65 mph			V=70 mph			V=75 mph			V=80 mph		
	e (%)	Maximum Relative Slope		e (%)	Maximum Relative Slope		e (%)	Maximum Relative Slope		e (%)	Maximum Relative Slope		e (%)	Maximum Relative Slope		e (%)	Maximum Relative Slope		e (%)	Maximum Relative Slope	
		L (ft.)	L <sub>r</sub> (ft.)		L (ft.)	L <sub>r</sub> (ft.)		L (ft.)	L <sub>r</sub> (ft.)		L (ft.)	L <sub>r</sub> (ft.)		L (ft.)	L <sub>r</sub> (ft.)		L (ft.)	L <sub>r</sub> (ft.)		L (ft.)	L <sub>r</sub> (ft.)
23000	NC	0	0	NC	0	0	NC	0	0	NC	0	0	NC	0	0	NC	0	0	NC	0	0
20000	NC	0	0	NC	0	0	NC	0	0	NC	0	0	NC	0	0	NC	0	0	NC	0	0
17000	NC	0	0	NC	0	0	NC	0	0	NC	0	0	NC	0	0	NC	0	0	NC	0	0
14000	NC	0	0	NC	0	0	NC	0	0	NC	0	0	NC	0	0	NC	0	0	2.0	63	69
12000	NC	0	0	NC	0	0	NC	0	0	NC	0	0	NC	0	0	NC	0	0	2.0	63	76
10000	NC	0	0	NC	0	0	NC	0	0	NC	0	0	NC	0	0	NC	0	0	2.1	63	103
8000	NC	0	0	2.0	51	51	2.0	53	53	2.3	56	73	2.5	60	90	2.8	63	113	3.1	69	144
6000	2.0	48	48	2.2	51	61	2.6	53	85	2.9	56	106	3.2	60	132	3.5	63	158	4.0	69	206
5000	2.2	48	58	2.6	51	82	3.0	53	106	3.3	56	129	3.7	60	162	4.1	63	196	4.6	69	247
4000	2.7	48	82	3.1	51	107	3.6	53	138	4.0	56	168	4.4	60	204	4.9	63	246	5.5	69	309
3500	3.0	48	96	3.5	51	128	3.9	53	154	4.4	56	190	4.9	60	234	5.3	63	271	5.9	69	337
3000	3.4	48	115	3.8	51	143	4.3	53	176	4.8	56	212	5.4	60	264	5.7	63	297	Rmin = 3050		
2500	3.8	48	134	4.3	51	168	4.8	53	202	5.3	56	240	5.8	60	288	6.0	63	315	Rmin = 2500		
2000	4.3	48	158	4.9	51	199	5.4	53	234	5.8	56	268	Rmin = 2040			Rmin = 1660					
1800	4.6	48	173	5.1	51	209	5.6	53	245	6.0	56	280	Rmin = 1330			Rmin = 1060					
1600	4.9	48	187	5.4	51	225	5.8	53	255	Rmin = 833			Rmin = 833								
1400	5.2	48	202	5.7	51	240	6.0	53	266	Rmin = 833			Rmin = 833								
1200	5.5	48	216	5.9	51	250	Rmin = 833			Rmin = 833			Rmin = 833								
1000	5.9	48	235	Rmin = 833			Rmin = 833			Rmin = 833			Rmin = 833								
900	6.0	48	240	Rmin = 833			Rmin = 833			Rmin = 833			Rmin = 833								

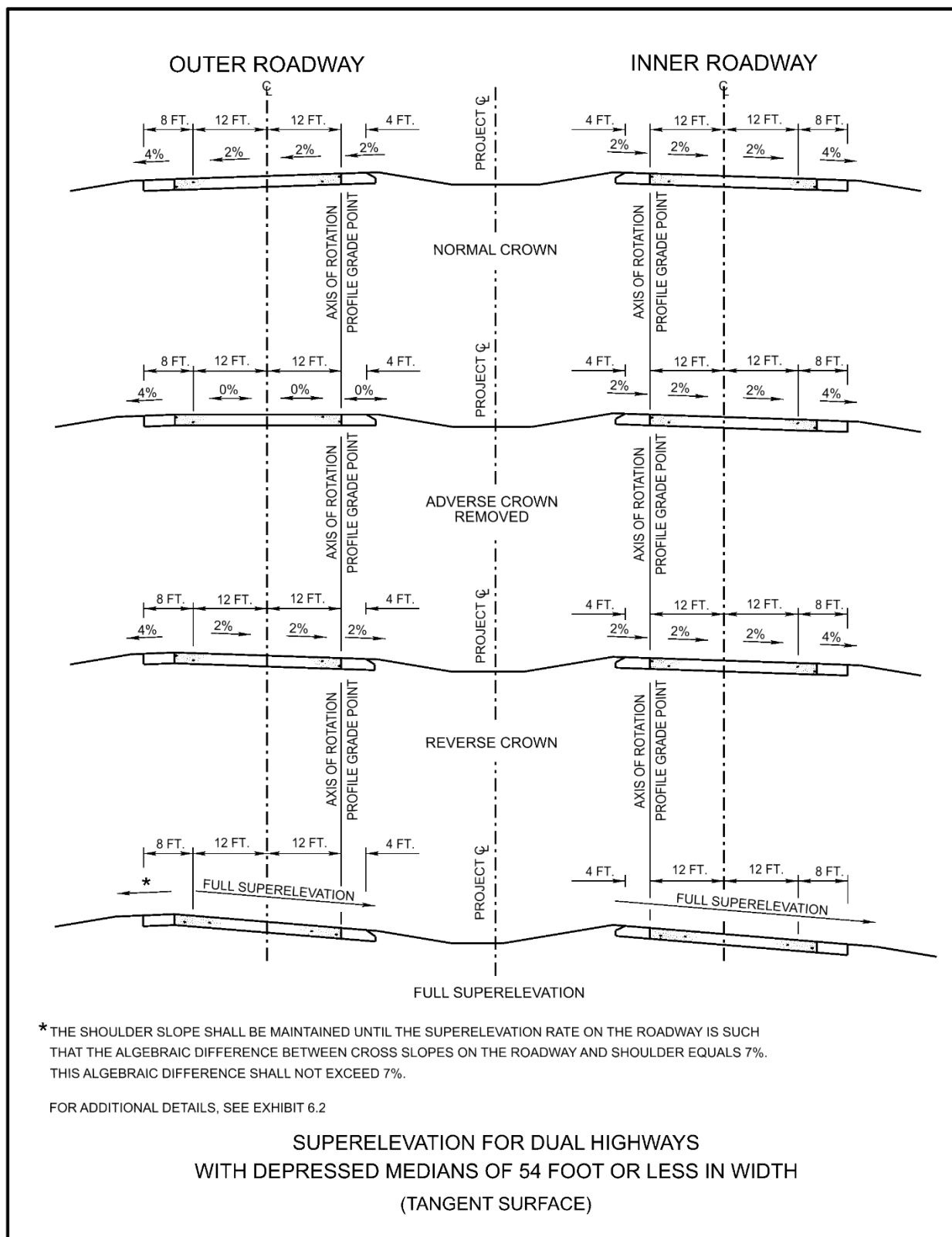
**e<sub>max</sub> = 6%**

Source: Adapted from "A Policy on Geometric Design of Highways and Streets", (Reference 3.1), Eq. 3-12 thru 3-24. For additional information see Reference 3.1, Tables 3-9 & 3-16.

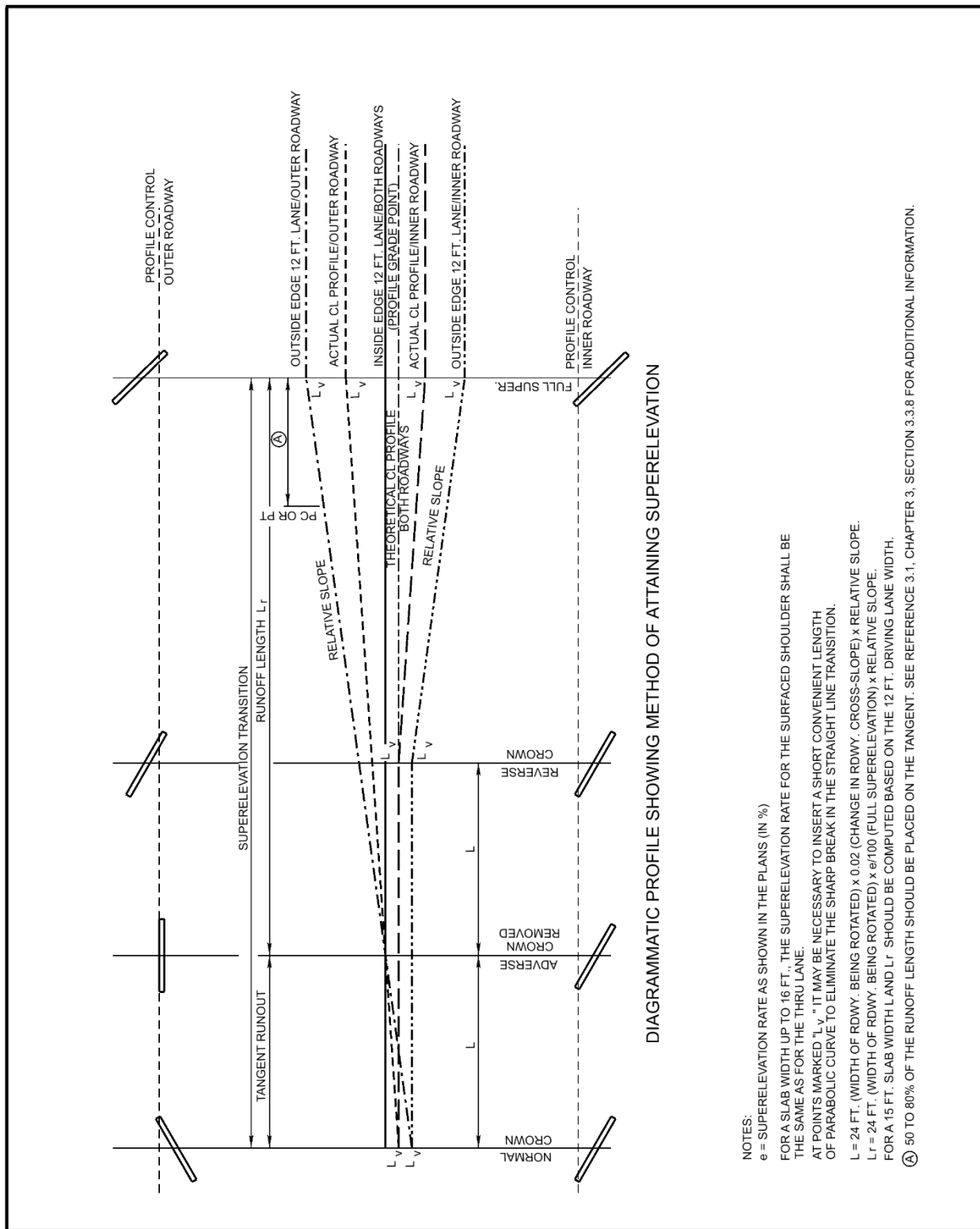
KEY:

- V = Assumed design speed
- e = Rate of superlevation
- L = Tangent runoff based on a 12 ft. lane
- L<sub>r</sub> = Minimum length of superlevation runoff based on a 24 ft. roadway
- NC = Normal crown section
- Notes: For 4 lane divided roadways with medians greater than 40 ft. in width, use the relative gradient given for the 2 lane roadway in Exhibit 3.3

**Exhibit 3.4c Superlevation Data for Dual Highways (Crowned Surface)  
 Depressed Median Width = 54 Foot or Less  
 Values for Design Elements Related to Design Speed and Horizontal Curvature  
 (e<sub>max</sub>=6%)**



**Exhibit 3.5a Superelevation Data for Dual Highways (Tangent Surface)  
 Depressed Median Width = 54 Foot or Less  
 Typical Sections**



**Exhibit 3.5b Super-elevation Data for Dual Highways (Tangent Surface)  
 Depressed Median Width = 54 Foot or Less  
 Diagrammatic Profile**



Radius of Curve (ft.)	V=50 mph		V=55 mph		V=60 mph		V=65 mph		V=70 mph		V=75 mph		V=80 mph	
	e (%)	L <sub>r</sub> (ft.)	e (%)	L <sub>r</sub> (ft.)	e (%)	L <sub>r</sub> (ft.)	e (%)	L <sub>r</sub> (ft.)	e (%)	L <sub>r</sub> (ft.)	e (%)	L <sub>r</sub> (ft.)	e (%)	L <sub>r</sub> (ft.)
23000	NC	0	NC	0	NC	0	NC	0	NC	0	NC	0	NC	0
20000	NC	0	NC	0	NC	0	NC	0	NC	0	NC	0	NC	0
17000	NC	0	NC	0	NC	0	NC	0	NC	0	NC	0	NC	0
14000	NC	0	NC	0	NC	0	NC	0	NC	0	NC	0	NC	0
12000	NC	0	NC	0	NC	0	2.0	84	2.0	84	2.0	84	2.0	84
10000	NC	0	NC	0	2.0	80	2.0	84	2.1	90	2.3	95	2.5	103
8000	NC	0	2.0	77	2.0	80	2.3	84	2.5	90	2.8	95	3.1	103
6000	2.0	72	2.2	77	2.6	80	2.9	84	3.2	90	3.5	95	4.0	103
5000	2.2	72	2.6	77	3.0	80	3.3	84	3.7	90	4.1	95	4.6	103
4000	2.7	72	3.1	77	3.6	80	4.0	84	4.4	90	4.9	95	5.5	103
3500	3.0	72	3.5	77	3.9	80	4.4	84	4.9	90	5.3	95	5.9	103
3000	3.4	72	3.8	77	4.3	80	4.8	84	5.4	90	5.7	95	6.0	103
2500	3.8	72	4.3	77	4.8	80	5.3	84	5.8	90	6.0	95	6.0	103
2000	4.3	72	4.9	77	5.4	80	5.6	80	5.8	84	6.0	95	6.0	103
1800	4.6	72	5.1	77	5.6	80	5.6	80	5.8	84	6.0	95	6.0	103
1600	4.9	72	5.4	77	5.8	80	5.8	80	6.0	84	6.0	95	6.0	103
1400	5.2	72	5.7	77	6.0	80	6.0	80	6.0	84	6.0	95	6.0	103
1200	5.5	72	5.9	77	6.0	80	6.0	84	6.0	84	6.0	95	6.0	103
1000	5.9	72	6.0	77	6.0	80	6.0	84	6.0	84	6.0	95	6.0	103
900	6.0	72	6.0	77	6.0	80	6.0	84	6.0	84	6.0	95	6.0	103

**e<sub>max</sub> = 6%**

Source: Adapted from "A Policy on Geometric Design of Highways and Streets", (Reference 3.1), Eq. 3-12 thru 3-24. For additional information see Reference 3.1, Tables 3-9 & 3-16.

KEY:

- V = Assumed design speed
- e = Rate of superelevation
- L = Tangent runoff based on a 24 ft. roadway
- L<sub>r</sub> = Minimum length of superelevation runoff based on a 24 ft. roadway
- NC = Normal crown section

**Exhibit 3.5c Superelevation Data for Dual Highways (Tangent Surface)**

**Depressed Median Width = 54 Foot or Less**

**Values for Design Elements Related to Design Speed and Horizontal Curvature (e<sub>max</sub>=6%)**

R<sub>min</sub> = 833

R<sub>min</sub> = 1060

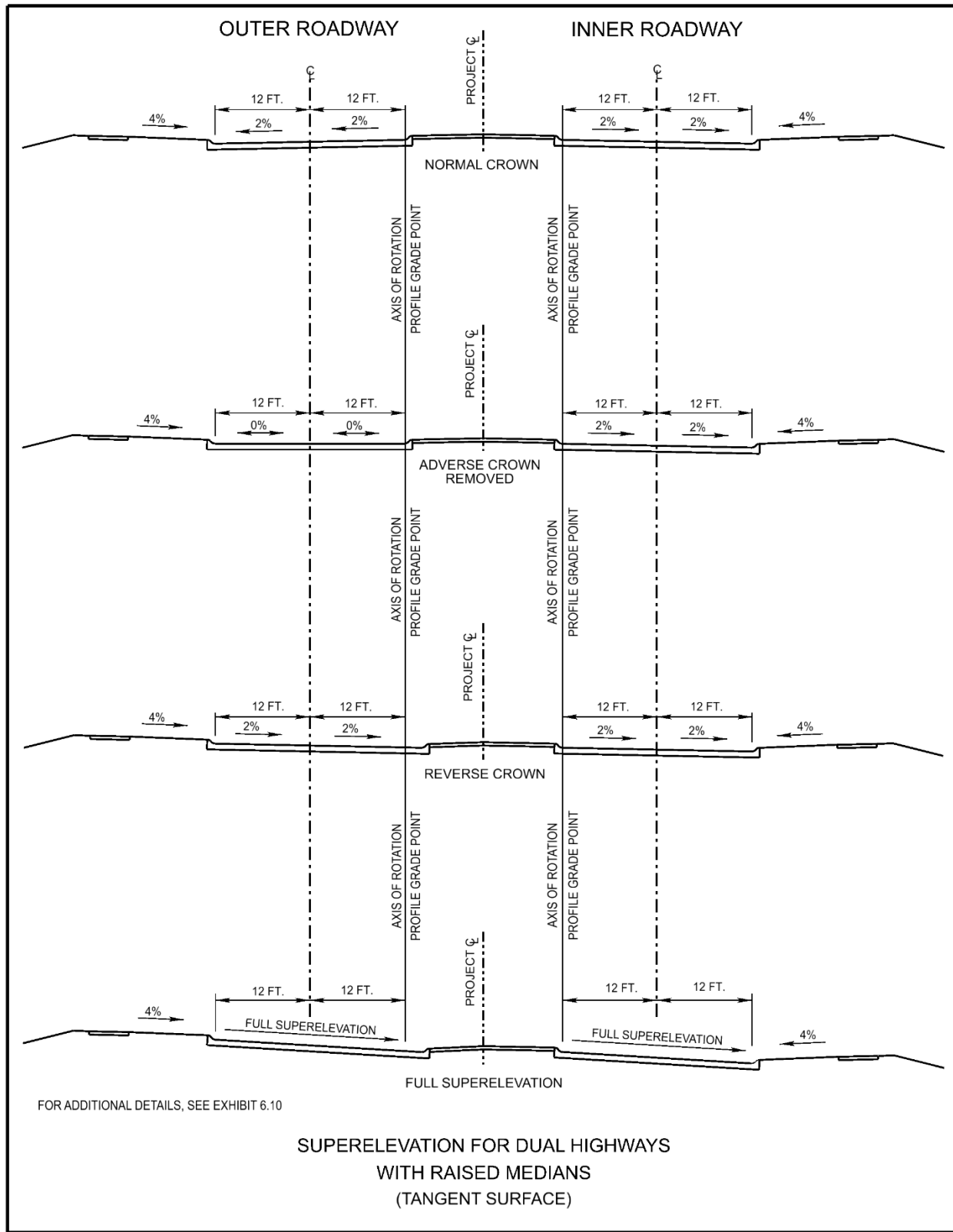
R<sub>min</sub> = 1330

R<sub>min</sub> = 1660

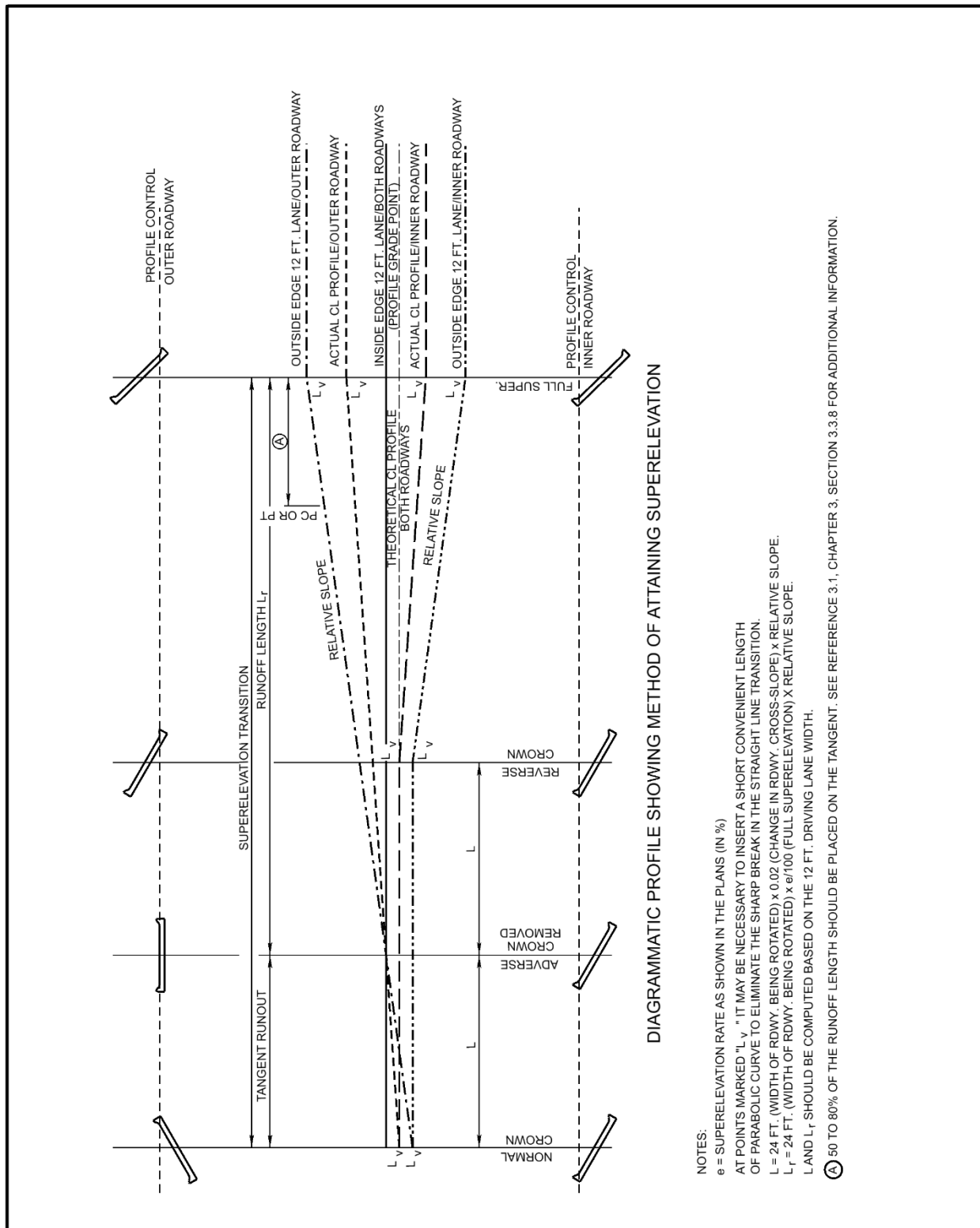
R<sub>min</sub> = 2040

R<sub>min</sub> = 2500

R<sub>min</sub> = 3050



**Exhibit 3.6a Superelevation Data for Dual Highways w/Raised Median Typical Sections**



**Exhibit 3.6b Super-elevation Data for Dual Highways w/Raised Median Diagrammatic Profile**

Radius of Curve (ft.)	V=25 mph			V=30 mph			V=35 mph			V=40 mph			V=45 mph		
	e (%)	Maximum Relative Slope		e (%)	Maximum Relative Slope		e (%)	Maximum Relative Slope		e (%)	Maximum Relative Slope		e (%)	Maximum Relative Slope	
		107.25:1			114:1			120.75:1			129:1			138.75:1	
	L (ft.)	L <sub>r</sub> (ft.)	L (ft.)	L <sub>r</sub> (ft.)	L (ft.)	L <sub>r</sub> (ft.)	L (ft.)	L <sub>r</sub> (ft.)	L (ft.)	L <sub>r</sub> (ft.)	L (ft.)	L <sub>r</sub> (ft.)	L (ft.)	L <sub>r</sub> (ft.)	
8000	NC	0	0	NC	0	0	NC	0	0	NC	0	0	NC	0	0
6000	NC	0	0	NC	0	0	NC	0	0	NC	0	0	NC	0	0
5000	NC	0	0	NC	0	0	NC	0	0	NC	0	0	2.0	67	67
4000	NC	0	0	NC	0	0	NC	0	0	2.0	62	62	2.0	67	67
3500	NC	0	0	NC	0	0	2.0	58	58	2.0	62	62	2.2	67	73
3000	NC	0	0	NC	0	0	2.0	58	58	2.1	62	65	2.4	67	80
2500	NC	0	0	2.0	55	55	2.0	58	58	2.3	62	71	2.6	67	87
2000	2.0	51	51	2.0	55	55	2.3	58	67	2.6	62	80	2.8	67	93
1800	2.0	51	51	2.0	55	55	2.4	58	70	2.7	62	84	3.0	67	100
1600	2.0	51	51	2.2	55	60	2.5	58	72	2.8	62	87	3.2	67	107
1400	2.0	51	51	2.3	55	63	2.6	58	75	3.0	62	93	3.3	67	110
1200	2.1	51	54	2.4	55	66	2.8	58	81	3.2	62	99	3.6	67	120
1000	2.3	51	59	2.6	55	71	3.0	58	87	3.4	62	105	3.8	67	127
900	2.4	51	62	2.7	55	74	3.1	58	90	3.6	62	111	3.9	67	130
800	2.4	51	62	2.8	55	77	3.3	58	96	3.7	62	115	4.0	67	133
700	2.5	51	64	3.0	55	82	3.4	58	99	3.9	62	121	Rmin = 711		
600	2.7	51	69	3.2	55	88	3.6	58	104	4.0	62	124			
500	2.8	51	72	3.4	55	93	3.9	58	113	Rmin = 533					
450	2.9	51	75	3.5	55	96	4.0	58	116						
400	3.1	51	80	3.6	55	98	4.0	58	116						
350	3.2	51	82	3.8	55	104	Rmin = 371								
300	3.4	51	88	3.9	55	107									
250	3.6	51	93	4.0	55	109									
200	3.8	51	98	Rmin = 250											

Rmin = 154

KEY:

- V = Assumed design speed
- e = Rate of superelevation
- L = Tangent runout based on a 24 ft. roadway
- L<sub>r</sub> = Minimum length of superelevation runoff based on a 24 ft. roadway
- NC = Normal crown section

Note: For values for a high-speed roadway (> 45 mph), see Exhibit 3.5c.

$$e_{max} = 4\%$$

Source: Adapted from "A Policy on Geometric Design of Highways and Streets", (Reference 3.1), Eq. 3-12 thru 3-24. For additional information see Reference 3.1, Tables 3-13 & 3-16.

**Exhibit 3.6c Superelevation Data for Dual Highways w/Raised Median Values for Design Elements Related to Design Speed and Horizontal Curvature (e<sub>max</sub>=4%)**

### 3. VERTICAL ALIGNMENT DESIGN

The vertical alignment (profile grade line) is a reference line which establishes the elevation of the pavement and other features of the highway. Vertical alignment is influenced by such factors as:

- Design speed
- Design year traffic volumes
- Environmental concerns
- Location (e.g. in a Flood Plain)
- Topography
- Earthwork
- Horizontal alignment
- Functional classification of the roadway
- Type of improvement
- Vertical clearances
- Geology
- Drainage control
- Construction costs
- Appearance considerations
- Vehicle operating characteristics (trucks)

The performance of heavy vehicles on grades is a significant factor in the development of the vertical alignment.

A practical vertical alignment design will be economically sound and minimize impacts to environmentally sensitive areas while meeting sight distance and other design requirements for the design classification of the highway. Environmental considerations and impacts are a vital component of the design process; the roadway designer shall coordinate with the **Environmental Section** in **PDD** in the development of, and in any subsequent alteration to, the vertical alignment. The vertical alignment should not be changed during the Plan Details Phase (Clarity Activity 5500).

Projects should be designed to produce balanced earthwork whenever practicable. Adjustments to the vertical alignment are usually preferred to ditch widening. For additional discussion see Chapter Seven: Earthwork, Section 1, of this manual.

There should be a smooth transition between the proposed profile grade line and the existing grade line of an adjacent highway section. Connections with previously constructed projects should be compatible with the design speed of the proposed project. A connecting profile grade line should be established which satisfactorily joins to the existing alignment. Existing grade lines should be considered for 2,000 feet or more, if practicable, to address the sight distance beyond the proposed project limits.

See Section 3.4, "Vertical Alignment", in Chapter 3 of the *Green Book* (Ref. 3.1) for additional information.

### 3.A Grades

#### 3.A.1 Maximum Grades

A Policy on Design Standards Interstate System (Ref. 3.8) and the *Green Book* (Ref. 3.1) establish the applicable maximum grades for use on the National Highway System (NHS). The **Board of Public Roads Classifications and Standards** establishes the maximum allowable grades for State highways in the Nebraska Minimum Design Standards (MDS) (Ref. 3.2) (<https://dot.nebraska.gov/media/1z1n5kmb/nac-428-rules-regs-nbcs.pdf>). Grades steeper than those given shall only be used with an approved design exception from the **Federal Highway Administration (FHWA)** and/or an approved design relaxation from the **Board of Public Roads Classifications and Standards** (See Chapter One: Roadway Design Standards, Section 10, of this manual). Grades which are less than the maximum should be used whenever practicable.

#### 3.A.2 Minimum Grades For Drainage

1. Rural Curbed Roadways and Bridges: A minimum grade of 0.50% is acceptable. Flatter grades may cause stormwater runoff to spread across the traveled way.
2. Urban Curbed Roadways: A minimum grade of 0.35% is acceptable. Flatter grades, down to and including 0.20%, may be used with **Unit Head** approval. As an alternative to a grade flatter than 0.35%, rolling the gutterline and warping the centerline grade line at a minimum slope of 0.35% may be considered.
3. Non-curbed Roadways: Level longitudinal gradients are acceptable where the pavement is crowned 2% or more, provided that consideration is given to the need for special ditches.
4. Superelevation Runout: To facilitate pavement drainage, a minimum grade of 1.5% shall be maintained through the area where the adverse crown has been removed. A flatter grade, down to and including 0.5%, may be used with **Unit Head** approval.

#### 3.A.3 Critical Length of Grade

Critical length of grade is the maximum length of a designated upgrade on which a loaded truck can operate without an unreasonable reduction in speed. For normal design purposes, a maximum speed reduction of 10 mph is acceptable. If this speed reduction is exceeded, the designer should consider shortening the length of grade, flattening the grade, or adding a climbing lane.

#### 3.A.4 Climbing Lanes

The **Traffic Engineering Division (Traffic Engineering)** analyzes the need for climbing lanes based on capacity and operations characteristics. The type of roadway facility is usually taken into consideration in the climbing lane analysis. Climbing lanes may be provided on arterial highways based on speed differential and capacity analysis. Climbing lanes may be provided on collector two-lane highways based on speed reduction only. Climbing lanes should be used to provide uniformity of operation rather than to avoid extreme congestion and disruption. Climbing lanes are applicable on multilane highways where extreme grade conditions reduce the level of service below that provided in adjacent roadway sections. Climbing lanes on multilane facilities may not be warranted until several years after construction; for this condition there may be an economic advantage in designing and grading for, but deferring the pavement construction of, climbing lanes on multilane facilities. EXHIBIT 3.7 summarizes **NDOT** standards for the design of climbing lanes. See Section 3.4.3, "Climbing Lanes", in Chapter 3 of the *Green Book* (Ref. 3.1) for additional information.

Design Element	Desirable	Minimum
Lane Width	Same as approach roadway.	Same as approach roadway.
Shoulder Width	Same as approach roadway. For turf shoulders, same as minimum requirement.	Expressway: Same as approach roadway. Other: four feet paved plus a two feet turf transition. (4)
Cross Slope on Tangent	Same as adjacent travel lane.	Same as adjacent travel lane.
Superelevation	(1)	(1)
Beginning of Full-Width Lane	Near the Vertical Point of Tangency (VPT) of the grade.	Where the truck speed is 10 mph below highway design speed or is at 45 mph, whichever is less. (2)
End of Full-Width Lane (3)	Where the truck has reached highway design speed.	Where the truck has reached 10 mph below highway design speed. (2)
Entering Taper	1:25	300 feet
Exiting Taper	1:50	600 feet
Minimum Full-Width Length (3)	NA	1000 feet

1. For horizontal curves on climbing lanes, determine the proper superelevation of the climbing lane on the high side by reading the applicable superelevation table for  $V = 40$  mph or the design speed, whichever is less (See Section 2.B of this chapter). This reflects the slower operating speeds of the climbing lane. The maximum allowable difference in cross slope between the travel lane and the climbing lane is 4%.
2. See Chapter 3 of A Policy on Geometric Design of Highways and Streets (Ref. 3.1), **FIGURE 3-21**, to determine truck deceleration and acceleration rates.
3. The designer will provide sufficient decision sight distance and length of auxiliary lane past the crest of a vertical curve to allow for the completion of the merger maneuver. The designer should coordinate the design of the auxiliary lane with **Traffic Engineering**.
4. If there is a mailbox located within the climbing lane, the mailbox turnout width will be 10 feet, eight feet of which will be surfaced. See the Standard/Special Plans Book (Standard Plans) (Ref. 3.3), Standard Plan No. 307 (<https://dot.nebraska.gov/business-center/design-consultant/stand-spec-manual/>).

**Exhibit 3.7 Standards for Climbing Lanes**

### 3.B Vertical Curves

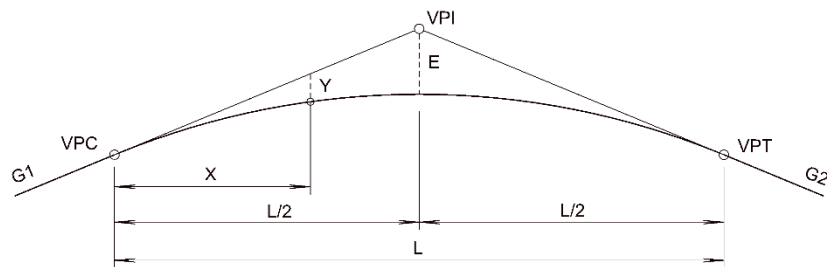
Vertical curves join two intersecting tangents to provide a smooth transition between changes in grade. Vertical curves are not required on low-speed roadways ( $\leq 45$  mph) where the algebraic difference in grades is less than 1%; high-speed roadways ( $\geq 50$  mph) will generally require a vertical curve when the change in grade is greater than 0.5%. Curves must be long enough to provide desirable stopping sight distance but should not be flattened to such an extent as to make drainage a problem. A series of angular breaks in lieu of a vertical curve is not an acceptable design. For additional information see NCHRP Synthesis 299, Recent Geometric Design Research for Improved Safety and Operations (Ref. 3.7).

#### 3.B.1 **Vertical Curve Computations**

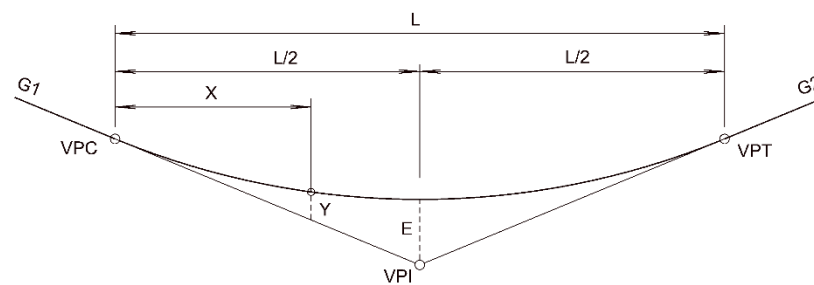
**NDOT** uses the symmetrical parabolic curve. Symmetrical curves are those with equal tangent lengths at the point where the curve is divided by the vertical point of intersection (VPI) of the two tangents. Asymmetrical vertical curves (curves with unequal tangent lengths) are sometimes used in unique situations, such as to provide vertical clearance at a bridge structure where a symmetrical curve will not work. Equations for asymmetric curves may be found in many engineering manuals. Compound curves designed in the vertical plane may also be used in these situations.

Dimensions and equations for use in symmetrical vertical curve computations are shown in EXHIBIT 3.8. The symbols, abbreviations, and formulas apply to both crest and sag vertical curves. It is **NDOT** practice to design vertical curves so that the vertical PC and PT fall on even stationing.





CREST VERTICAL CURVE



SAG VERTICAL CURVE

Vertical Curve Symbols and Abbreviations	Vertical Curve Formulas
<p>VPC Vertical point of curvature (beginning of curve)</p> <p>VPI Vertical point of intersection of grades</p> <p>VPT Vertical point of tangency (end of curve)</p> <p>G1 Grade at beginning of curve, ft./ft.</p> <p>G2 Grade at end of curve, ft./ft.</p> <p>E External distance from VPI to curve</p> <p>L Horizontal length of curve</p> <p>R Rate of change of grade, ft./ft.</p> <p>E<sub>0</sub> Elevation of VPC</p> <p>V Elevation of VPI</p> <p>E<sub>T</sub> Elevation of VPT</p> <p>X Distance of any point on the curve from the VPC</p> <p>Y Tangent offset to curve at X distance from the VPC</p> <p>E<sub>X</sub> Elevation of any point X distance from the VPC</p> <p>X<sub>S</sub> Distance from the VPC to lowest point of a sag curve or highest point of a crest curve</p> <p>E<sub>S</sub> Elevation of lowest point on a sag curve or highest point on a crest curve</p> <p>A Algebraic difference of grades, %</p>	<p><math>V = E_0 + [L/2 \times G1]</math></p> <p><math>E_T = V - [L/2 \times G2]</math></p> <p><math>R = (G2 - G1)/L</math></p> <p><math>E_X = E_0 + G1X + 1/2RX^2</math></p> <p><math>E_S = E_0 - [G1^2 \div 2R]</math></p> <p><math>X_S = -G1/R</math> (if <math>X_S</math> is negative or if <math>X_S &gt; L</math>, the curve doesn't have a high point or a low point)</p> <p><math>A = G1 - G2</math></p> <p><math>E = AL/800</math></p> <p><math>Y = (X \div L/2)^2 \times E</math></p>

Exhibit 3.8 Elements and Formulas for Symmetrical Parabolic Vertical Curves

### 3.B.2 Design

The primary design control for the minimum length of a vertical curve is stopping sight distance. The minimum vertical curve length in feet should be approximately three times the design speed of the roadway when the length of curve is less than the desirable stopping sight distance. See Section 3.2.2, "Stopping Sight Distance", in Chapter 3 of the *Green Book* (Ref. 3.1) for additional information.

The relationship of the curve length (L) and the algebraic difference in percent of grades (A) or L/A, is termed the K value. The K value is a measure of curvature, defined as the horizontal distance in feet required to effect a 1% change in grade. K values for roadways on new alignment, with minimum and desirable stopping sight distance for crest and sag vertical curves, are shown in EXHIBITS 3.9 & 3.14 for a range of design speeds and intersection configurations.

The desirable K values shown in EXHIBITS 3.9 & 3.14 should be used for all New and Reconstructed projects. The desirable K values provide intersection stopping sight distance for passenger cars for various intersection conditions. If the desirable K values cannot be met, the vertical curve may be designed to any length down to and including stopping sight distance with **Unit Head** approval and a decision letter to the project file (See Chapter One: Roadway Design Standards, Section 10.C, of this manual). For intersection conditions other than listed in the exhibits, intersections and driveways (except for field entrances) will be evaluated for intersection sight distance according to the procedures presented in Section 9.5, "Intersection Sight Distance", in Chapter 9 of the *Green Book* (Ref. 3.1).

The minimum K values shown in EXHIBITS 3.9 & 3.14 are from **TABLES 3-35 AND 3-37** in the *Green Book* (Ref. 3.1) and are for stopping sight distance **only** and do not include intersection sight distance. When the minimum K values are used for New and Reconstructed projects, intersections and driveways (except for field entrances) will be evaluated for intersection sight distance according to the procedures presented in Section 9.5, "Intersection Sight Distance", in Chapter 9 of the *Green Book* (Ref. 3.1). The use of the minimum K values will require **Unit Head** approval and a decision letter to the project file (See Chapter One: Roadway Design Standards, Section 10.C, of this manual).

The use of K values below the stopping sight values given in EXHIBITS 3.9 & 3.14 for a New and Reconstructed project will require **Roadway Design Engineer** approval, a design exception from the **FHWA** for projects on the NHS, and/or a relaxation of the *MDS* (Ref. 3.2) (See Chapter One: Roadway Design Standards, Section 10.C, of this manual).

The use of an intersection sight distance less than that given in **TABLE 9-7** in Chapter 9 of the *Green Book* (Ref. 3.1) will require **Unit Head** approval and a decision letter to the project file (See Chapter One: Roadway Design Standards, Section 10.C, of this manual).

Special attention to pavement drainage must be exercised where a K value in excess of 167 is used, a minimum roadway cross-slope of 1.5% should be maintained.

U.S. Customary								
Crest Vertical Curve								
Design Speed (mph)	① Minimum Stopping Sight Distance		② Desirable Stopping Sight Distance (2-Lane, Left-Turn Condition and 2-Lane w/TWLTL, Left-Turn Condition)		③ Desirable Stopping Sight Distance (5-Lane and 4-Lane Divided w/18 ft. Median, Left-Turn Condition)		④ Desirable Stopping Sight Distance (4-Lane Divided w/40 ft. Median, Left-Turn Condition) Crowned Lanes **	
	Length (ft.)	Rate of Vertical Curvature K	Length (ft.)	Rate of Vertical Curvature K	Length (ft.)	Rate of Vertical Curvature K	Length (ft.)	Rate of Vertical Curvature K
15	80	3	195	18	215	21	240	27
20	115	7	260	31	285	38	320	47
25	155	12	325	49	355	58	400	74
30	200	19	390	70	430	86	485	109
35	250	29	455	96	500	116	565	148
40	305	44	520	125	570	151	645	193
45	360	61	580	156	640	190	725	244
50	425	84	645	193	715	237	805	300
55	495	114	710	234	785	286	890	367
60	570	151	775	278	855	339	970	436
65	645	193	840	327	925	396	1,050	510
70	730	247	905	380	1,000	463	1,130	592
75	820	312	970	436	1,070	531	1,215	684
80	910	384	1,035	496	1,140	602	1,290	770

K is the length of curve per percent algebraic difference in grades (A).  $K = L/A$

TWLTL = Two Way Left-Turn Lane, See Chapter Four: Intersections, Driveways and Channelization, Section 5.B.2, of this manual.

\*\* Check intersection sight distance if building tangent lanes.

- ① Based on a 3.5 ft. eye height and an object height of 2 ft., (See A Policy on Geometric Design of Highways and Streets, Ref. 3.1, Section 3.2.6). These values do not meet intersection sight distance requirements. All intersections and driveways, except for field entrances, shall be evaluated for intersection sight distance according to the procedures outlined in Chapter 9 of Ref. 3.1. Minimum K values may be used on New and Reconstructed projects with **Design Unit Head** approval.
- ② Includes intersection sight distance for the given conditions (for other intersection conditions, see Chapter Four: Intersections, Driveways and Channelization of this manual and Chapter 9 of Ref. 3.1). Based on an 8.8 sec. gap in traffic, a 2.33 ft. eye height, and an object height of 3.25 ft. See Exhibit 3.10a of this manual for the derivation of the eye and object heights. The use of K values for less than the desirable stopping sight distance requires **Design Unit Head** approval.
- ③ Includes intersection sight distance for the given conditions (for other intersection conditions, see Chapter Four: Intersections, Driveways and Channelization of this manual and Chapter 9 of Ref. 3.1). Based on a 9.7 sec. gap in traffic, a 2.0 ft. eye height, and an object height of 2.9 ft. See Exhibit 3.10b of this manual for the derivation of the eye and object heights. The use of K values for less than the desirable stopping sight distance requires **Design Unit Head** approval.
- ④ Includes intersection sight distance for the given conditions (for other intersection conditions, see Chapter Four: Intersections, Driveways and Channelization of this manual and Chapter 9 of Ref. 3.1). Based on a 11.0 sec. gap in traffic, a 2.50 ft. eye height, and an object height of 3.38 ft. See Exhibit 3.10c of this manual for the derivation of the eye and object heights. The use of K values for less than the desirable stopping sight distance requires **Design Unit Head** approval.

Note: The **NDOT** time gap is arrived at by adding an initial time gap of 7.5 sec. (Case B-1, Left-Turn from the Minor Road condition from Chapter 9 of Ref. 3.1) plus 0.8 sec. (0.2 sec. x 4 for a driveway/intersection approach at a 4% grade) plus 0.5 sec. for each additional 12 ft. lane (or for each 12 ft. width of median).

### Exhibit 3.9a Design Controls for Crest Vertical Curves

U.S. Customary						
Crest Vertical Curve						
Design Speed (mph)	⑤ Desirable Stopping Sight Distance (4-Lane Divided w/50 ft. Median, Left-Turn Condition) Crowned Lanes **		Intersection Sight Distance (4-Lane Divided w/54 ft. Median)			
			⑥ Case B-3 Crossing Maneuver (Traversing the Traffic & Rt.-Turn Lane to Enter the Median Refuge)		⑦ Case B-1 Left-Turn Condition (From the Median)	
	Length (ft.)	Rate of Vertical Curvature K	Length (ft.)	Rate of Vertical Curvature K	Length (ft.)	Rate of Vertical Curvature K
15	250	29	170	13	170	13
20	330	50	225	23	225	23
25	415	80	285	38	280	36
30	500	116	340	54	335	52
35	580	156	395	72	390	70
40	665	205	455	96	445	92
45	745	257	510	120	500	116
50	830	319	565	148	555	143
55	915	388	620	178	610	172
60	995	459	680	214	665	205
65	1,080	540	735	250	720	240
70	1,160	624	790	289	775	278
75	1,245	718	850	335	830	319
80	1,330	820	# 910	384	# 910	384

K is the length of curve per percent algebraic difference in grades (A).  $K = L/A$

TWLTL = Two Way Left-Turn Lane, See Chapter Four: Intersections, Driveways and Channelization, Section 5.B.2, of this manual.

\*\* Check intersection sight distance if building tangent lanes.

# The stopping sight distance was substituted for the intersection sight distance, which is less than the stopping sight distance.

⑤ Includes intersection sight distance for the given conditions (for other intersection conditions, see Chapter Four: Intersections, Driveways and Channelization of this manual and Chapter 9 of Ref. 3.1). Based on a 11.3 sec. gap in traffic, a 2.50 ft. eye height, and an object height of 3.38 ft. See Exhibit 3.10c of this manual for the derivation of the eye and object heights. The use of K values for less than the desirable stopping sight distance requires **Design Unit Head** approval.

Note: The **NDOT** time gap is arrived at by adding an initial time gap of 7.5 sec. (Case B-1, Left-Turn from the Minor Road condition from Chapter 9 of Ref. 3.1) plus 0.8 sec. (0.2 sec. x 4 for a driveway/intersection approach at a 4% grade) plus 0.5 sec. for each additional 12 ft. lane (or for each 12 ft. width of median).

⑥ The Crossing Maneuver time gap of 7.7 sec. (provided for the Type "A" Median Break) is arrived at by adding an initial time gap of 6.5 sec. (Case B-3, Crossing Maneuver from the Minor Road condition from Chapter 9 of Ref. 3.1) plus 1.2 sec. (4 ft. shoulder/8 ft. median/4 ft. shoulder and 12 ft. turn lane at 0.5 sec. per each additional 12 ft. of width).

⑦ Source: **Table 9-7** of the *Green Book* (Ref. 3.1). Based on a time gap of 7.5 sec. (**Table 9-6**)

### Exhibit 3.9b Design Controls for Crest Vertical Curves

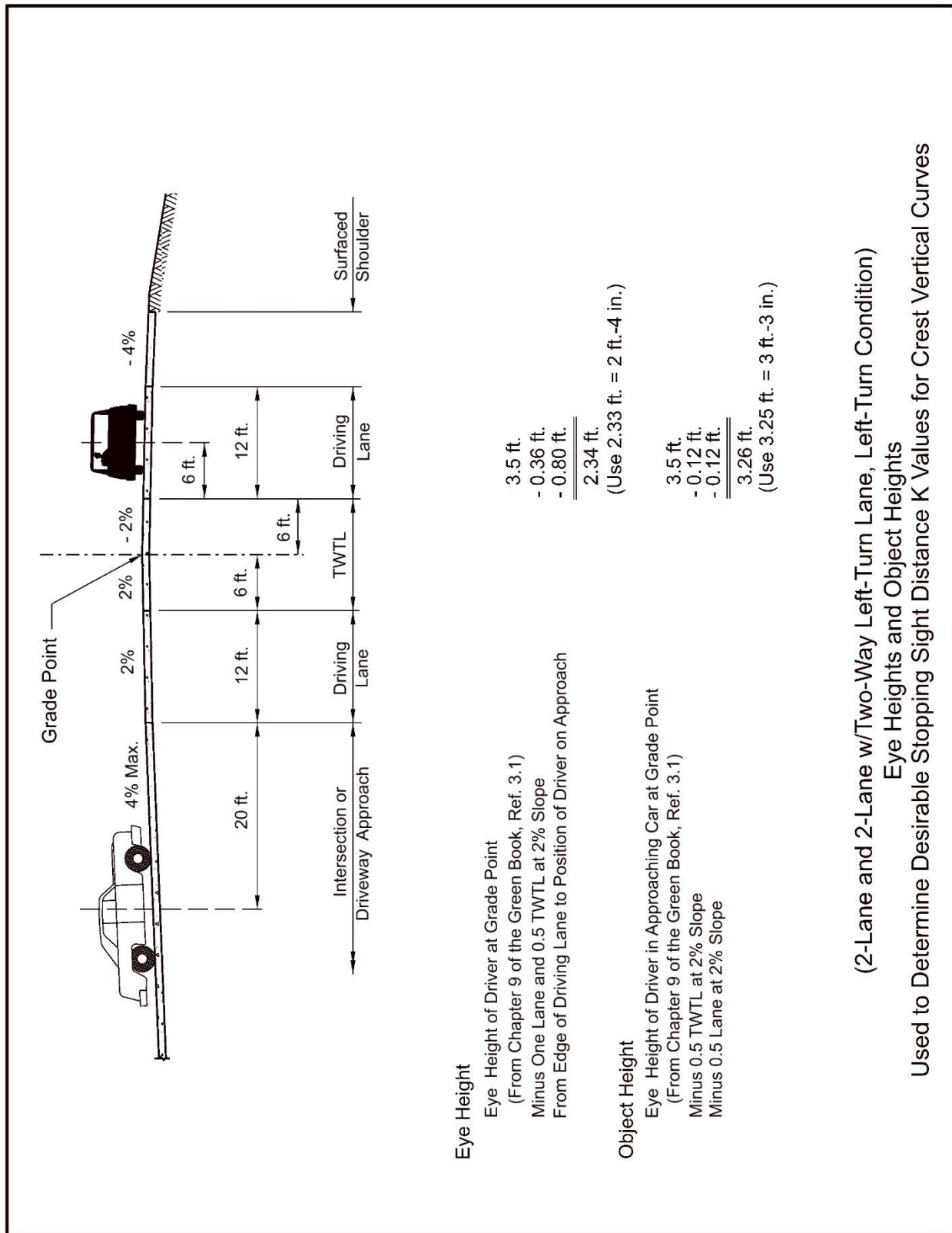
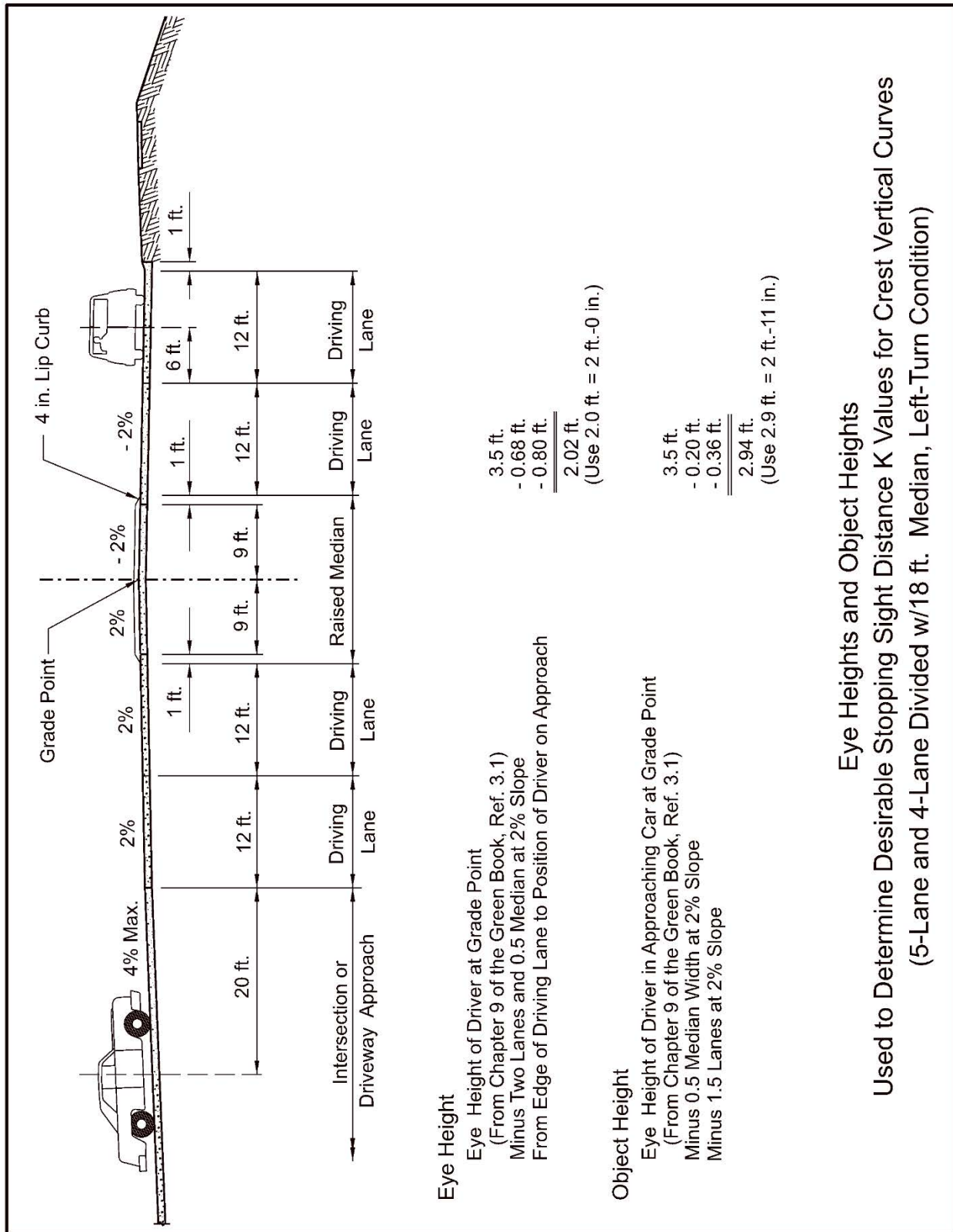
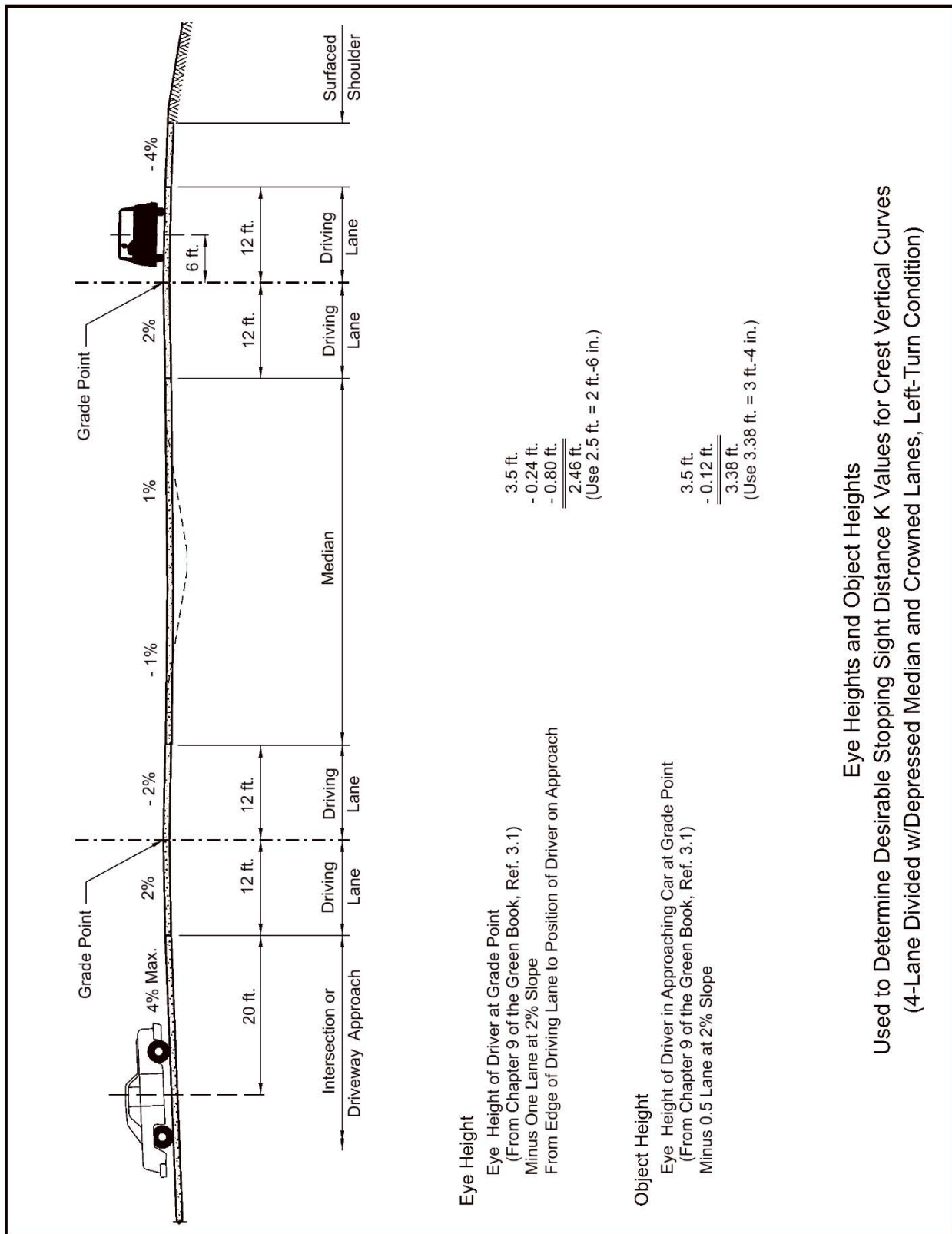


Exhibit 3.10a Eye and Object Heights used to Determine Desirable K Values (Crest Vertical Curves)



**Exhibit 3.10b Eye and Object Heights used to Determine Desirable K Values (Crest Vertical Curves)**



**Exhibit 3.10c Eye and Object Heights used to Determine Desirable K Values (Crest Vertical Curves)**

### 3.C Crest Vertical Curves

#### 3.C.1 Stopping Sight Distance

EXHIBIT 3.11 depicts the stopping sight distance height of eye and height of object assumptions for crest vertical curves. The equation given below may be used to determine the length of crest vertical curve which provides the **NDOT desirable** stopping sight distance at each design speed (desirable stopping sight distance includes intersection sight distance).

$$S_d = 1.47 \times \text{speed (mph)} \times \text{time (sec)} \text{ (Eq. 9-1 in the } \textit{Green Book}, \text{ Ref. 3.1)}$$

Where:

$S_d$  = stopping sight distance = intersection sight distance in feet.

Time = acceptable time gap in traffic (in seconds) based on intersection conditions (See Chapter Four: Intersections, Driveways and Channelization of this manual and Chapter 3 of the *Green Book*, Ref. 3.1). **NDOT** uses a time gap of 8.8 sec. for the two-lane left-turn condition (the **NDOT** time gap is arrived at by adding an initial time gap of 7.5 sec. (Case B1, left-turn condition from Section 9.5.3 in Chapter 9 of the *Green Book*, Ref. 3.1) plus 0.8 sec. (0.2 sec. x 4 for a driveway/intersection approach at a 4% grade) plus 0.5 sec. for each additional 12-foot lane (or for each 12 feet of median width).

Equations 3-43 & 3-44 in the *Green Book* (Ref. 3.1) may be used to determine the stopping sight distance for crest vertical curves.

When designing a crest vertical curve, the designer should refer to EXHIBIT 3.9 in choosing an appropriate K value. Multiply K by A (algebraic difference in grade) to obtain the desirable length of vertical curve (L).

The following equation is used to determine a K value for a condition not shown in EXHIBIT 3.9:

$$K = S_d^2/2158$$

This equation is derived from Eq. 3-44 in the *Green Book* (Ref. 3.1),  $L = AS^2/2158$ , substituting  $L/K$  for A and intersection sight distance for S.

When the desirable sight distance cannot be attained, the vertical curve may be designed to any length down to and including the stopping sight distance shown in EXHIBIT 3.9 with **Unit Head** approval and a decision letter to the project file (See Chapter One: Roadway Design Standards, Section 10.C, of this manual).

The minimum K values shown in EXHIBIT 3.9 are from **TABLE 3-35** in the *Green Book* (Ref. 3.1) and are for stopping sight distance **only** and do not include intersection sight distance. For intersection conditions other than listed in the exhibit, intersections and driveways on New and Reconstructed projects (except for field entrances) will be evaluated for intersection sight distance according to the procedures presented in Section 9.5, "Intersection Sight Distance", in Chapter 9 of the *Green Book* (Ref. 3.1). The use of an intersection sight distance less than that given in Chapter 9 of the *Green Book* (Ref. 3.1) will require **Unit Head** approval and a decision letter to the project file (See Chapter One: Roadway Design Standards, Section 10.C, of this manual).



The use of K values below the sight distance values given in [EXHIBIT 3.9](#) for a New and Reconstructed project will require **Roadway Design Engineer** approval and may require a relaxation of the *MDS* (Ref. 3.2) and/or design exception from the **FHWA** (See Chapter One: [Roadway Design Standards](#), Section 10.C, of this manual).

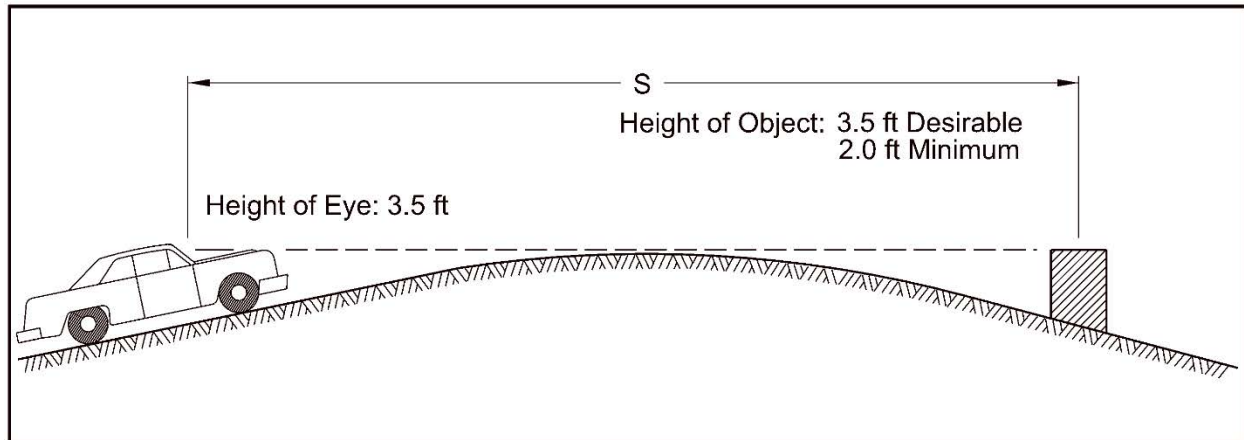


Exhibit 3.11 Crest Vertical Curve Design Elements

### 3.C.2 Two-Lane, Two-Way Roadways - Passing Sight Distance

Passing sight distance is not one of the principal controlling design criteria (See Chapter One: [Roadway Design Standards](#), Section 8, of this manual). It is not practicable to design crest vertical curves to provide for passing sight distance. For evaluation, **TABLE 3-4** and Equations 3-46 and 3-47 in the Green Book (Ref. 3.1) may be used to determine the minimum length of vertical curve for passing sight distance. See Section 3.2.4, "Passing Sight Distance for Two-Lane Highways", in Chapter 3 of the Green Book (Ref. 3.1) for additional information.

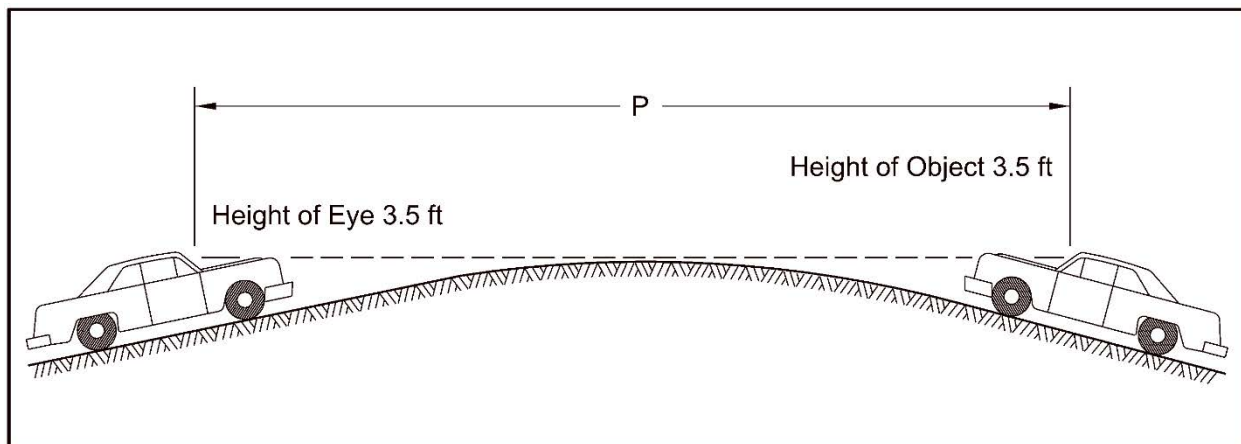


Exhibit 3.12 Passing Sight Distance Design Considerations

### 3.D Sag Vertical Curves

#### 3.D.1 Stopping Sight Distance

The minimum length of a sag vertical curve depends mainly on headlight distance at night except in areas where roadway lighting is present (See [EXHIBIT 3.13](#)). For overall safety on highways, it is desirable that the stopping sight distance be nearly the same as the headlight beam distance.

The equation given below may be used to calculate the length of sag vertical curve which provides the **NDOT desirable** stopping sight distance at each design speed (desirable stopping sight distance includes intersection sight distance).

$$S_d = 1.47 \times \text{speed (mph)} \times \text{time (sec)} \text{ (Eq. 9-1 in the } \textit{Green Book}, \text{ Ref. 3.1)}$$

Where:

$S_d$  = headlight beam distance = stopping sight distance in feet.

Time = acceptable time gap in traffic (in seconds) based on intersection conditions (See Section 9.5.3 in Chapter 9 of the *Green Book*, Ref. 3.1). **NDOT** uses a time gap of 8.8 sec. for the two-lane, left-turn condition (the **NDOT** time gap is arrived at by adding an initial time gap of 7.5 sec. (Case B-1, left-turn condition from Section 9.5.3 in Chapter 9 of the *Green Book*, Ref. 3.1) plus 0.8 sec. (0.2 sec. x 4 for a driveway/intersection approach at a 4% grade) plus 0.5 sec. for each additional 12-foot lane (or for each 12 feet of median width).

Equations 3-48 & 3-50 in the *Green Book* (Ref. 3.1) may be used to determine the stopping sight distance for sag vertical curves.

[EXHIBIT 3.14](#) lists the desirable sight distances and the stopping sight distances for various design speeds. When the desirable sight distance cannot be attained, the vertical curve may be designed down to and including the stopping sight distance with **Unit Head** approval and a decision letter to the project file (See Chapter One: [Roadway Design Standards](#), Section 10.C, of this manual).

The minimum K values shown in [EXHIBIT 3.14](#) are for stopping sight distance **only** and do not include intersection sight distance. For intersection conditions other than those listed in the exhibit, intersections and driveways on New and Reconstructed projects (except for field entrances) will be evaluated for intersection sight distance according to the procedures presented in Section 9.5, "Intersection Sight Distance", in Chapter 9 of the *Green Book* (Ref. 3.1). The use of an intersection sight distance less than that given in the *Green Book* (Ref. 3.1) will require **Unit Head** approval and a decision letter to the project file (See Chapter One: [Roadway Design Standards](#), Section 10.C, of this manual).

The following equation is used to determine a K value for a condition not shown in [EXHIBIT 3.14](#):

$$K = S_d^2 / (400 + 3.5S_d)$$

This equation is derived from Eq. 3-49 in the *Green Book* (Ref. 3.1),  $L = AS^2/400 + 3.5S$ , substituting  $L/K$  for A and intersection sight distance for S.

The use of K values below the sight distance values given in [EXHIBIT 3.14](#) for a New and Reconstructed project will require **Roadway Design Engineer** approval and may require a relaxation of the *MDS* (Ref. 3.2) and/or design exception from the **FHWA** (See Chapter One: [Roadway Design Standards](#), Section 10.C, of this manual).

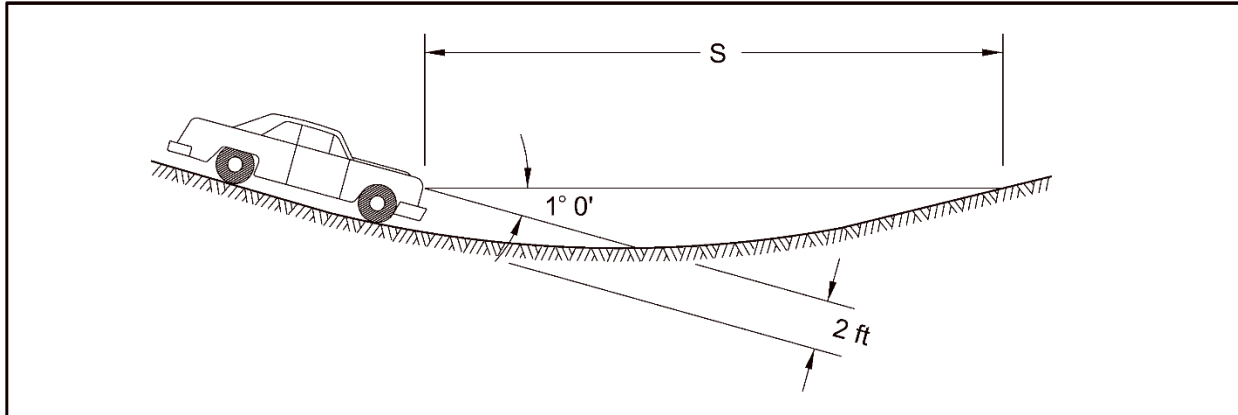


Exhibit 3.13 Sag Vertical Curve Design Elements

U.S. Customary								
Sag Vertical Curve								
Design Speed (mph)	① Minimum Stopping Sight Distance		② Desirable Stopping Sight Distance (2-Lane, Left-Turn Condition and 2-Lane w/TWLT, Left-Turn Condition)		③ Desirable Stopping Sight Distance (5-Lane and 4-Lane Divided w/18 ft. Median, Left-Turn Condition)		④ Desirable Stopping Sight Distance (4-Lane Divided w/40 ft. Median, Left-Turn Condition)	
	Length (ft.)	Rate of Vertical Curvature K	Length (ft.)	Rate of Vertical Curvature K	Length (ft.)	Rate of Vertical Curvature K	Length (ft.)	Rate of Vertical Curvature K
15	80	10	195	35	215	40	240	46
20	115	17	260	52	285	58	320	67
25	155	26	325	69	355	77	400	89
30	200	37	390	86	430	97	485	112
35	250	49	455	104	500	116	565	134
40	305	64	520	122	570	136	645	156
45	360	79	580	138	640	155	725	179
50	425	96	645	157	715	176	805	201
55	495	115	710	175	785	196	890	225
60	570	136	775	193	855	215	970	248
65	645	157	840	211	925	235	1,050	270
70	730	181	905	230	1,000	256	1,130	293
75	820	206	970	248	1,070	276	1,215	317
80	910	231	1,035	266	1,140	296	1,290	339

K is the length of curve per percent algebraic difference in grades (A).  $K = L/A$

TWLT = Two Way Left-Turn Lane, See Chapter Four: Intersections, Driveways and Channelization, Section 5.B.2, of this manual.

- ① Based on a 3.5 ft. eye height, a 2 ft. headlight height and a 1° upward divergence of the light beam, (See A Policy on Geometric Design of Highways and Streets, Ref. 3.1, Section 3.4.6.3). These values do not meet intersection sight distance requirements. All intersections and driveways, except for field entrances, shall be evaluated for intersection sight distance according to the procedures outlined in Chapter 9 of Ref. 3.1. Minimum K values may be used on New and Reconstructed projects with **Design Unit Head** approval.
- ② Includes intersection sight distance for the given conditions (for other intersection conditions, see Chapter Four: Intersections, Driveways and Channelization of this manual and Chapter 9 of Ref. 3.1). Based on an 8.8 sec. gap in traffic, a 3.5 ft. eye height, a 2 ft. headlight height and a 1° upward divergence of the light beam (See Ref. 3.1, Chapter 3). The light beam distance has been set to the intersection sight distance. The use of K values for less than the desirable stopping sight distance requires **Design Unit Head** approval.
- ③ Includes intersection sight distance for the given conditions (for other intersection conditions, see Chapter Four: Intersections, Driveways and Channelization of this manual and Chapter 9 of Ref. 3.1). Based on a 9.7 sec. gap in traffic, a 3.5 ft. eye height, a 2 ft. headlight height and a 1° upward divergence of the light beam (See Ref. 3.1, Chapter 3). The light beam distance has been set to the intersection sight distance. The use of K values for less than the desirable stopping sight distance requires **Design Unit Head** approval.
- ④ Includes intersection sight distance for the given conditions (for other intersection conditions, see Chapter Four: Intersections, Driveways and Channelization of this manual and Chapter 9 of Ref. 3.1). Based on a 11.0 sec. gap in traffic, a 3.5 ft. eye height, a 2 ft. headlight height and a 1° upward divergence of the light beam (See Ref. 3.1, Chapter 3). The light beam distance has been set to the intersection sight distance. The use of K values for less than the desirable stopping sight distance requires **Design Unit Head** approval.

Note: The **NDOT** time gap is arrived at by adding an initial time gap of 7.5 sec. (Case B-1, Left-Turn from the Minor Road condition from Chapter 9 of Ref. 3.1) plus 0.8 sec. (0.2 sec. x 4 for a driveway/intersection approach at a 4% grade) plus 0.5 sec. for each additional 12 ft. lane (or for each 12 ft. width of median).

**Exhibit 3.14a Design Controls for Sag Vertical Curves**

U.S. Customary						
Sag Vertical Curve						
Design Speed (mph)	⑤ Desirable Stopping Sight Distance (4-Lane Divided w/50 ft. Median, Left-Turn Condition) Crowned Lanes **		Intersection Sight Distance (4-Lane Divided w/54 ft. Median)			
			⑥ Case B-3 Crossing Maneuver (Traversing the Traffic & Rt.-Turn Lane to Enter the Median Refuge)		⑦ Case B-1 Left-Turn Condition (From the Median)	
	Length (ft.)	Rate of Vertical Curvature K	Length (ft.)	Rate of Vertical Curvature K	Length (ft.)	Rate of Vertical Curvature K
15	250	49	170	29	170	29
20	330	70	225	43	225	43
25	415	93	285	58	280	57
30	500	116	340	73	335	71
35	580	138	395	88	390	86
40	665	162	455	104	445	101
45	745	184	510	119	500	116
50	830	208	565	134	555	131
55	915	232	620	150	610	147
60	995	255	680	166	665	162
65	1,080	279	735	182	720	178
70	1,160	302	790	197	775	193
75	1,245	326	850	214	830	208
80	1,330	350	# 910	231	# 910	231

K is the length of curve per percent algebraic difference in grades (A).  $K = L/A$

TWLTL = Two Way Left-Turn Lane, See Chapter Four: Intersections, Driveways and Channelization, Section 5.B.2, of this manual.

\*\* Check intersection sight distance if building tangent lanes.

# The stopping sight distance was substituted for the intersection sight distance, which is less than the stopping sight distance.

⑤ Includes intersection sight distance for the given conditions (for other intersection conditions, see Chapter Four: Intersections, Driveways and Channelization of this manual and Chapter 9 of Ref. 3.1). Based on a 11.3 sec. gap in traffic, a 2.50 ft. eye height, and an object height of 3.38 ft. See Exhibit 3.10c of this manual for the derivation of the eye and object heights. The use of K values for less than the desirable stopping sight distance requires **Design Unit Head** approval.

Note: The **NDOT** time gap is arrived at by adding an initial time gap of 7.5 sec. (Case B-1, Left-Turn from the Minor Road condition from Chapter 9 of Ref. 3.1) plus 0.8 sec. (0.2 sec. x 4 for a driveway/intersection approach at a 4% grade) plus 0.5 sec. for each additional 12 ft. lane (or for each 12 ft. width of median).

⑥ The Crossing Maneuver time gap of 7.7 sec. (provided for the Type "A" Median Break) is arrived at by adding an initial time gap of 6.5 sec. (Case B-3, Crossing Maneuver from the Minor Road condition from Chapter 9 of Ref. 3.1) plus 1.2 sec. (4 ft. shoulder/8 ft. median/4 ft. shoulder and 12 ft. turn lane at 0.5 sec. per each additional 12 ft. of width).

⑦ Source: **Table 9-7** of the *Green Book* (Ref. 3.1). Based on a time gap of 7.5 sec. (**Table 9-6**)

**Exhibit 3.14b Design Controls for Sag Vertical Curves**

### 3.D.2 Comfort Criteria

Driver/passenger comfort is affected more by the change in vertical direction on sag vertical curves than on crest vertical curves. This is because the gravitational and centripetal forces are combining rather than opposing. The length of a sag vertical curve required to meet the comfort criteria is approximately 50% of that required to satisfy the stopping sight distance requirement (headlight distance). The minimum length of a sag vertical curve based on comfort criteria may be calculated using Equation 3-52 in the *Green Book* (Ref. 3.1).

### 3.D.3 Underpass Sight Distance

The designer should verify that, when sag vertical curves are used on underpasses, the overhead structure does not obstruct driver visibility. Equations 3-53 and 3-54 in the *Green Book* (Ref. 3.1) should be used to calculate the appropriate overhead clearance to provide the stopping sight distance.

Underpasses become a design control when the minimum length of sag vertical curve required for unobstructed sight distance exceeds the minimum length of curve required for stopping sight distance (headlight sight distance). The longer of the two lengths will control design.

### 3.D.4 Vertical Curve with Obstructions

The required minimum vertical clearance over or under an existing or future obstruction of known elevation often dictates that the vertical profile must pass through a specific point to satisfy minimum clearance criteria. The minimum vertical clearance will be measured from the high point of the roadway, including the shoulders. If the minimum vertical clearance point on the profile is located on a vertical curve, the curve length will be dependent upon the required elevation of the given point. "Sight Distance at Undercrossings" in Section 3.4.6.4 in Chapter 3 of the *Green Book* (Ref. 3.1) presents a procedure for calculating the length of vertical curve required to pass the curve through a specific point. "General Controls for Vertical Alignment" in Section 3.4.6.5 in Chapter 3 of the *Green Book* (Ref. 3.1) presents additional information on vertical clearance at undercrossings.

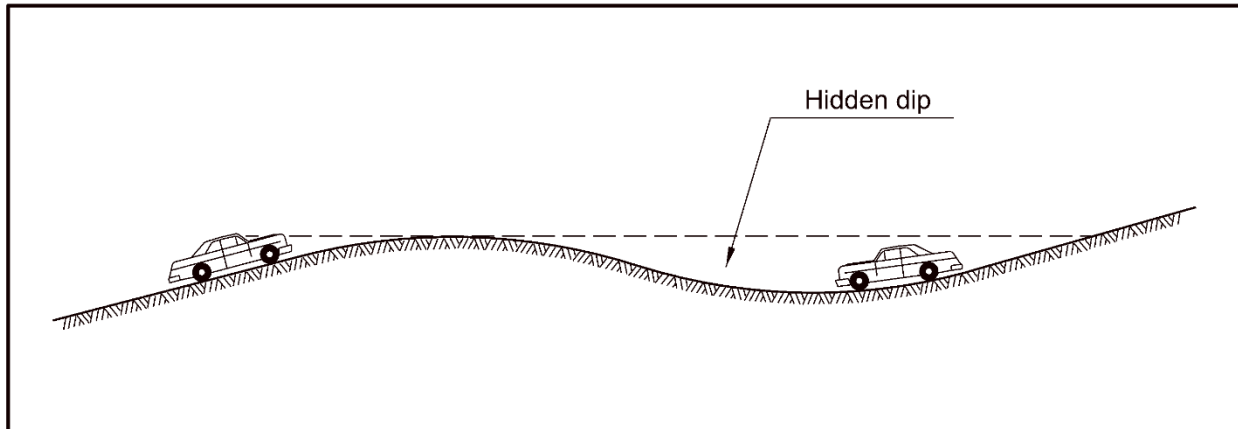
#### 3.D.4.a Minimum Vertical Clearances for Overhead Facilities

The roadway designer should always check the overhead clearance based on the high point of the roadway (including the shoulders), which may or may not be at the profile grade point, and should allow sufficient clearance for a future six inch overlay, if practicable.

1. Utilities: Vertical clearances for overhead utility facilities shall comply with all applicable state and national electrical codes. Utilities over the roadway shall never be less than 18 feet above the high point of the roadway, including the shoulders. For additional discussion see Chapter Ten: Miscellaneous Design Issues, Section 12, of this manual.
2. Signs or Signal Structures: Vertical clearances for overhead signs or signal structures shall comply with the Manual on Uniform Traffic Control Devices for Streets and Highways (Ref. 3.5) (<https://dot.nebraska.gov/business-center/contractor/mutcd/>).
3. Bridges: For information on allowable vertical clearances for bridge structures, see Chapter Ten: Miscellaneous Design Issues, Section 2, of this manual.
4. Airfields: For information on allowable airspace at airfields, see Chapter Ten: Miscellaneous Design Issues, Section 3, of this manual.

### 3.E Roller-Coaster Profile

“Roller-coaster” or “hidden-dip” profiles (See [EXHIBIT 3.15](#)) generally occur on relatively straight horizontal alignments where the roadway profile closely follows a rolling natural ground line. This type of profile should be avoided on New and Reconstructed projects.



**Exhibit 3.15 Roller Coaster Profile**

## 4. COMBINATION OF HORIZONTAL AND VERTICAL ALIGNMENT

The design of horizontal and vertical roadway alignments must be carefully coordinated. See Section 3.5, “Combinations of Horizontal and Vertical Alignment”, in Chapter 3 of the *Green Book* (Ref. 3.1) for guidance.

## 5. ALIGNMENT DESIGN VALUES

A summary of the basic alignment design values used by **NDOT** is presented below. Chapter Eleven: Highway Plans Assembly discusses the format and content of the sheets that make up a typical set of roadway design plans.

### 5.A Horizontal Alignment

The common horizontal alignment design values and the degree of accuracy to be shown on the plans include:

- Stationing - to the nearest 0.01 foot
- Radius of curvature - to the nearest 0.01 foot
- Superelevation runoff lengths - rounded to the next appropriate five feet
- All other curve data - to the nearest 0.01 foot, or to the nearest 0.01 second, whichever is applicable

Computations for the design of horizontal alignment assume a horizontal plane.

#### 5.A.1 Station Equations

Station equations may be utilized to avoid revising the stationing throughout the length of a project when changes are made from the original surveyed line in the field. The station equation links two station numbers, one that is correct when measuring on the line back of the equation and one that is correct when measuring on the line ahead of the equation.

### 5.B Vertical Alignment

The common vertical profile design values and the degree of accuracy to be shown on the plans include:

- Grades - expressed in percent rise (+) or fall (-) to the fourth decimal place
- Profile elevations - to the nearest 0.01 foot
- Vertical curve lengths - usually defined to even 100 feet



## 6. REFERENCES

- 3.1 American Association of State Highway and Transportation Officials, A Policy on Geometric Design of Highways and Streets (the *Green Book*), 2018.
- 3.2 Board of Public Roads Classifications and Standards, Nebraska Minimum Design Standards (MDS), Current Edition.  
(<https://dot.nebraska.gov/media/1z1n5kmb/nac-428-rules-regs-nbcs.pdf>)
- 3.3 Nebraska Department of Transportation, Standard/Special Plan Book (Standard Plans), Current Edition. (<https://dot.nebraska.gov/business-center/design-consultant/stand-spec-manual/>)
- 3.4 American Association of State Highway and Transportation Officials, Roadside Design Guide, Washington, DC, 2011.
- 3.5 United States Department of Transportation Federal Highway Administration, Manual on Uniform Traffic Control Devices for Streets and Highways, Washington, D.C., 2009.  
(<https://dot.nebraska.gov/business-center/contractor/mutcd/>)
- 3.6 Transportation Research Board, Highway Geometric Design and Operational Effects Issues, National Cooperative Highway Research Program (NCHRP) Report 1658, Washington, DC. 1999.
- 3.7 Transportation Research Board, Recent Geometric Design Research for Improved Safety and Operations, National Cooperative Highway Research Program (NCHRP) Synthesis 299, Washington, DC. 2001.
- 3.8 American Association of State Highway and Transportation Officials, A Policy on Design Standards Interstate System, Washington, D.C., 2005.
- 3.9 Nebraska Department of Transportation, Design Process Outline, Current Edition  
(<https://dot.nebraska.gov/business-center/design-consultant/>)



The information contained in Chapter Four: Intersections, Driveways and Channelization, dated May 2022, has been updated to reflect the October 2023 Errata. The errata incorporates DES 23-01: “Reduced Conflict Intersections” (approved by the Nebraska Division of the FHWA on June 21, 2023), addresses errors, changes in procedure, changes in NDOT department titles, changes in other Roadway Design Manual chapters and other reference material citations occurring since the latest publication of this chapter.

Chapter Four presents guidance for the design of New and Reconstructed projects; design guidance for 3R projects is provided in Chapter Seventeen.

# Chapter Four

## Intersections, Driveways and Channelization

### 1. INTERSECTIONS

Intersections are locations where two or more roadways or entrances cross and/or meet each other at the same elevation. The design of an intersection will affect the operation and capacity of the approach roadways.

Intersection design should consider driver expectancy, vehicle operating characteristics, and the intersection environment. Intersection design elements should be standardized as much as possible to avoid presenting unexpected or confusing situations to roadway users. The intent of intersection design should be the efficient movement of vehicles through intersections by the proper use and placement of design elements.

The environment of an intersection includes:

- The surrounding land use and zoning
- Traffic composition
- Traffic flows
- Non-motorized usage
- Traffic control
- Provisions for parking
- Public transit
- Signing
- Utilities
- Lighting
- Traffic barriers
- Roadway surface conditions

For a detailed discussion of intersection/driveway design see Chapter 4, Section 4.15.2 and Chapter 9, Section 9.11.6 of A Policy on Geometric Design of Highways and Streets (the *Green Book*) (Ref. 4.1), the **Federal Highway Administration’s (FHWA’s) Manual on Uniform Traffic Control Devices (MUTCD)** (Ref. 4.2) (<https://dot.nebraska.gov/business-center/contractor/mutcd/>), the State of Nebraska Supplement to the Manual on Uniform Traffic Control Devices (NE-MUTCD) (Ref. 4.3) (<https://dot.nebraska.gov/business-center/contractor/mutcd/>), and NCHRP Report 420, Impacts of Access Management Techniques (Ref. 4.5).

## 1.A Types Of Intersections

Intersections are usually either a three-leg or a four-leg design (See the *Green Book*, Ref. 4.1, FIGURES 9-5 through 9-10). Both three-leg and four-leg intersections may vary in size, shape, and channelization.

Intersections having five or more legs should be avoided. Measures to reduce vehicle collisions and improve the efficiency at these intersections include:

- Realignment of one or more of the intersecting legs
- Combining some of the traffic movements at adjacent intersections
- Making some legs one-way with the traffic direction away from the intersection
- Construct a roundabout

Many factors enter into the selection of intersection type, but the principal controls are:

- Design vehicle
- Design hour traffic volumes (DHV)
- Composition of traffic
- Design speed
- Type of traffic control
- Proximity of accesses

See Section 1.E of this chapter for additional information.

### 1.A.1 Unchannelized Intersections

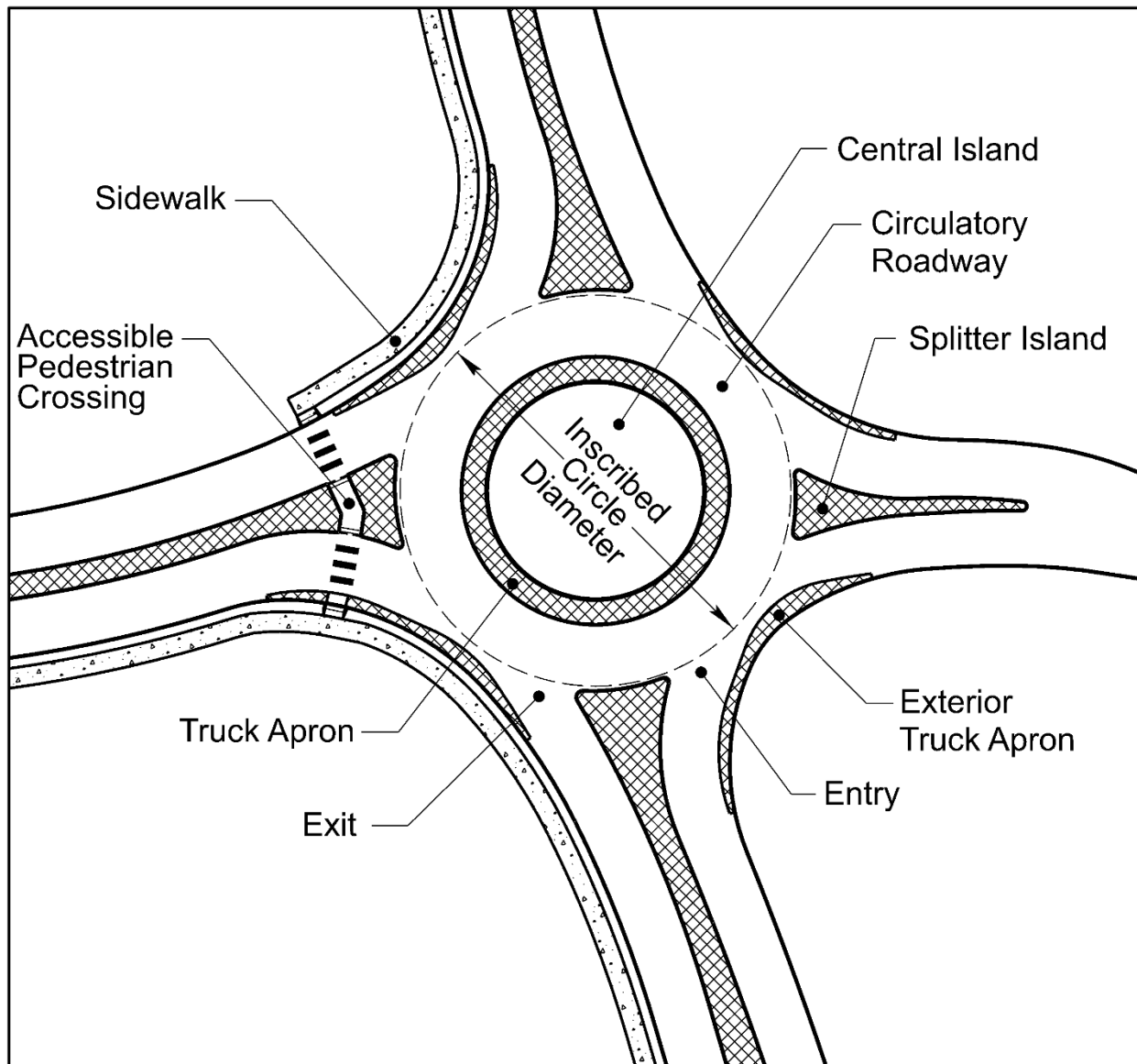
The most common type of intersection is the unchannelized, consisting of the crossing of two roadways at the same elevation connected by radius returns to accommodate the wheel paths of turning vehicles. Typical characteristics of unchannelized intersections are low turning movements and low overall traffic volumes.

### 1.A.2 Channelized Intersections

Channelized intersections separate conflicting traffic movements into definite paths of travel by use of pavement markings and/or curbs. A primary purpose of channelization is to provide reference points to enable a driver to predict the path of intersecting vehicles. Channelization also serves to segregate, store, and protect turning and crossing vehicles. Median and island channelization also provides a location for the installation of traffic control devices. See Section 5 of this chapter for further discussion of channelization.

### 1.A.3 Roundabouts

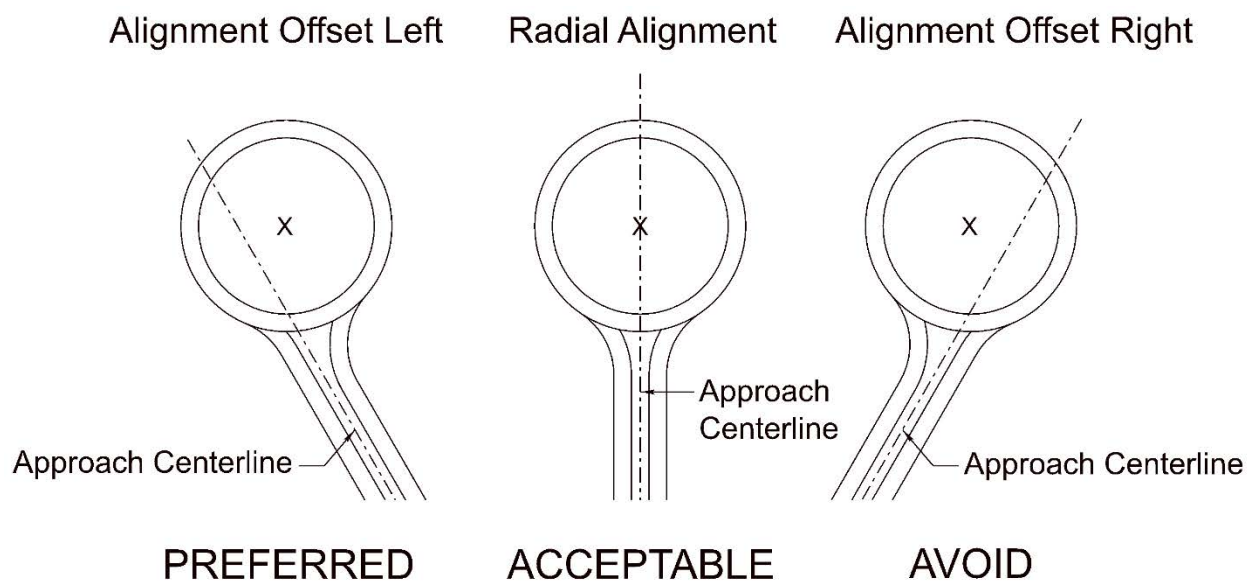
Roundabouts are circular intersections in which the traffic flows around a central island. Entry and exit to/from a roundabout is accomplished through a low-speed right turn, yielding to the traffic already in the roundabout, which substantially reduces the number, type, and severity of traffic accidents in the intersection (See [EXHIBIT 4.1](#) and **FIGURES 9-12, 9-13, 9-14, 9-61, and 9-62** of the *Green Book*, Ref. 4.1).



**Exhibit 4.1 Typical Elements of a Roundabout Intersection**

The **Nebraska Department of Transportation (NDOT)** will use the roundabout design guidance found in Chapter 6 of NCHRP Report 672, "Roundabouts: An Informational Guide", Second Edition (Ref. 4.18) (<https://www.trb.org/Main/Blurbs/164470.aspx>). Additional **NDOT** guidance includes:

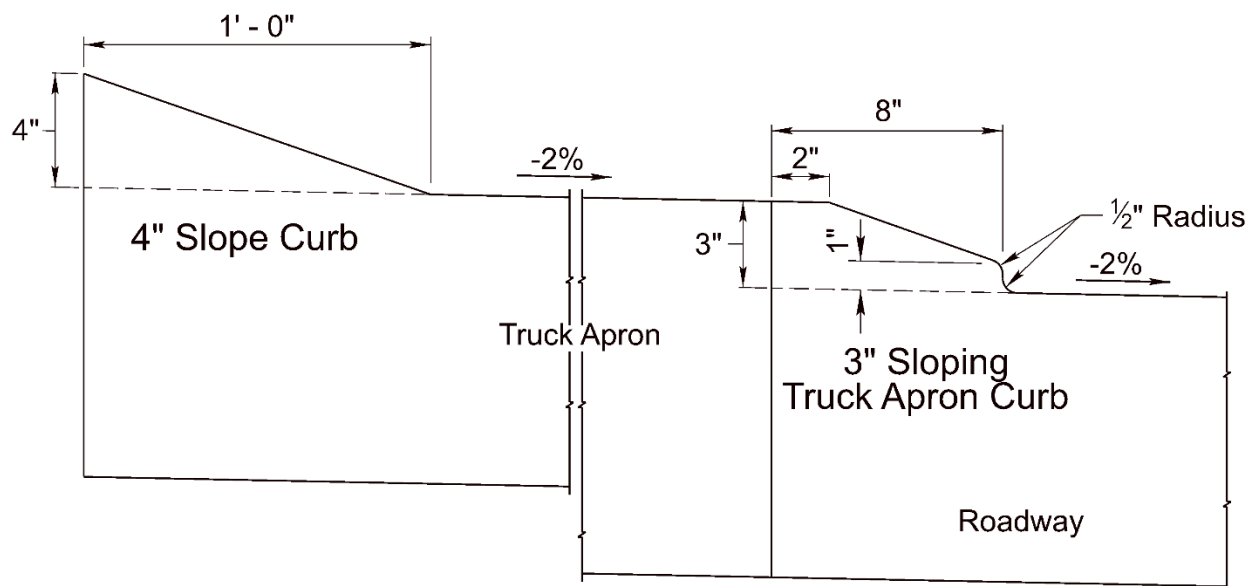
- **Design Vehicle:**
  1. The design vehicle for the intersection of all State Highways, rural and urban, will be the WB-67
  2. The design vehicle for urban roundabouts which do not involve a state highway will be based on the traffic composition
- **Assumed Running Speed within 400 feet of the Intersection:** 45 mph (See "Appropriate Design Speed for Horizontal Curves Approaching a Stop", Ref. 4.4, <http://govdocs.nebraska.gov/epubs/R6000/B016.0097-2004.pdf>)
- **Lanes:** The **Traffic Engineering Division (Traffic Engineering)** will recommend the number of lanes for the roundabout, including any auxiliary or by-pass lanes.
- **Alignment:**



- **Vertical Approach Grade:** +2% entering the roundabout (at the edge of the inscribed circular roadway) and for approximately  $\frac{1}{2}$  the length of the entry radius
- **Splitter Island:**
  1. **Splitter Island Length:** 200 feet minimum for rural high-speed roadways, 50 feet minimum for urban roadways
  2. **Roadway Taper Rate Approaching the Splitter Island:** 50:1 for rural high-speed roadways (design speed  $\geq$  50 mph); the taper rate should equal the posted speed limit (at a minimum) for low-speed (design speed  $\leq$  45 mph) roadways
  3. **Approach Roadway Width at the Splitter Island:** 16 feet to 18 feet back-of-curb to back-of curb
- **Splitter Island and Truck Apron:** Both the splitter island and the truck apron shall be textured and a different color than the pavement; exterior truck aprons will be flush with the adjacent lane

- **Curbs:**
  1. Beyond 400 feet of the inscribed circle, a four-inch sloping curb will be used for the outer curb and for any medians
  2. Within 400 feet of the inscribed circle, a six-inch integral curb will be used for the outer curb and for the splitter island (splitter islands on roundabouts **must** be raised)
  3. A three-inch sloping truck apron curb will be used for the outer radius of the center island truck apron (See [EXHIBIT 4.2](#))
  4. When required (the central island slopes towards the truck apron) a four-inch sloping curb will be used for the inner radius of the center island truck apron (See [EXHIBIT 4.2](#))
- **Curb Clearance:** A three-foot minimum clear distance will be maintained between the outside tire edge of the design vehicle wheel path and the back of the outer curb
- **Curb Inlet Location:** Avoid placing in the right-turn path of a truck
- **Drives:** In rare instances when a driveway must have direct access onto or near the roundabout it will look like a driveway (e.g. appropriate drive radius, use of a two-inch slope curb). All access, both on and near the roundabout, will be coordinated with **Traffic Engineering**
- **Pavement Joints:** Roundabout transverse and longitudinal joint widths will not exceed 14 feet
- **Lighting:** Lighting will be required on roundabouts

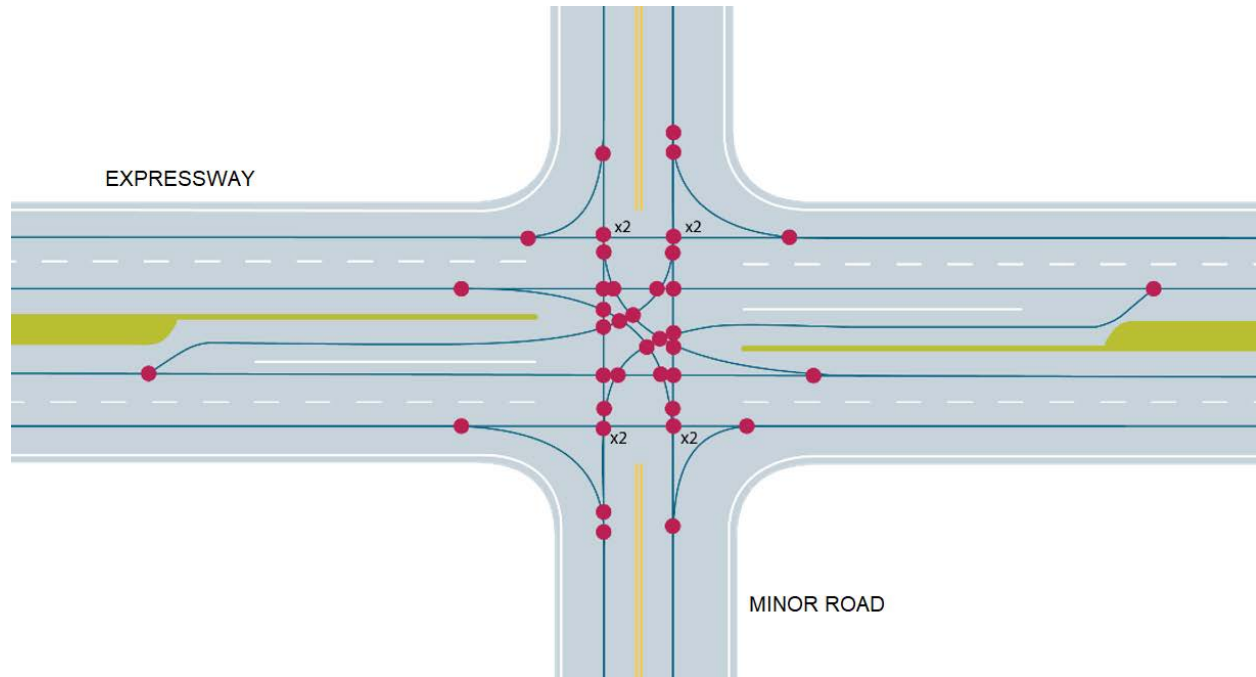
For additional information see Section 9.3.4, "Roundabouts" and Section 9.10, "Roundabout Design" in Chapter 9 of the *Green Book* (Ref. 4.1), [NCHRP Report 672](#) (Ref. 4.18), and Chapter Ten: [Miscellaneous Design Issues](#), Section 4.B.



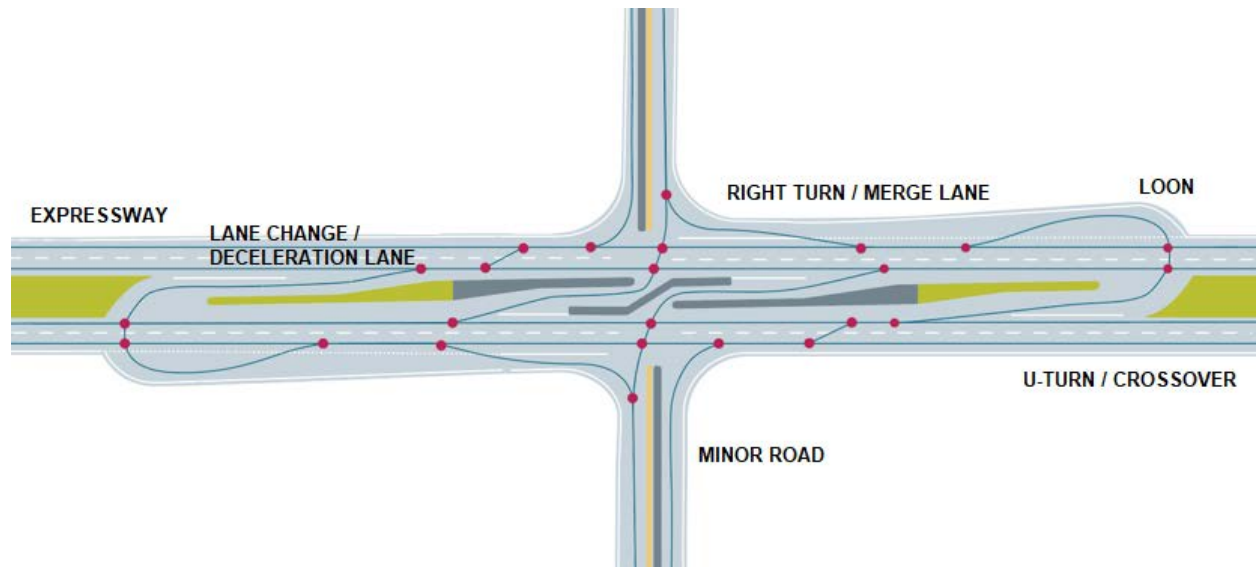
**Exhibit 4.2 Roundabout Intersection – Typical Truck Apron Curb Arrangement**

### 1.A.4 Reduced Conflict Intersections

Reduced Conflict Intersections (RCIs) (also known as Restricted Crossing U-Turns (RCUT) or J-Turns) are typically used by **NDOT** at the intersection of a rural four-lane divided expressway or State Highway and a lower volume minor road to reduce the frequency of higher severity crashes compared to a conventional intersection (See [EXHIBIT 4.3](#)).



**Traditional Intersection = 42 Points of Conflict**



**RCI = 24 Points of Conflict**

**Exhibit 4.3 Typical Reduced Conflict Intersection**



RCIs eliminate left-turns and through movements from the minor road. Drivers intending to perform these maneuvers are first required to make a right turn onto the expressway and then make a U-turn maneuver at a median opening downstream of the intersection. All movements (left-turns, right-turns, and through) remain available to traffic on the expressway at the intersection (See [EXHIBITS 4.3 & 4.4](#)).

The design of a retrofit RCI is dependent on the geometrics of the existing roadways and on the site conditions; there is no one size fits all solution. The designer will coordinate the design with **Traffic Engineering**. General **NDOT** design guidance for a RCI installation includes:

#### **Expressway or Four-Lane State Highway**

- **Design Vehicle:** The WB-67 is the design vehicle for the intersection of all expressways & major arterials.
- **Design Speed:** 70 mph
- **Shoulder Improvements:** The existing outside shoulder may be removed from the end of the Loon (the bulb opposite the median U-Turn provided for the design vehicle turn movement, see [EXHIBITS 4.3 & 4.5](#)) to the intersection with the minor road. The shoulder will be replaced from the end of the Loon to the intersection with a right-turn/merging lane, 12 feet wide with a two-foot right surfaced shoulder with full depth surfacing.
- **Right Turns from Expressway to Minor Road:** (See [EXHIBIT 4.3](#) and Section 1.D.3 of this chapter)
  - Existing parallel turn lanes may be retained, if approved by **Traffic Engineering** and/or there are right-of-way constrictions or environmental concerns. New right turn lanes should be designed as tapered offset (See [EXHIBIT 4.14](#)).
- **Left Turn Lanes from Expressway to Minor Road:** (See [EXHIBIT 4.4](#) and Section 1.D of this chapter)
  - Design Speed: 15-20 mph
  - Cross-Section: 12 feet wide with a four-foot integral left shoulder until the raised median, see below (dependent on median width and type)
  - The median should be raised at the intersection with a minimum width of four-foot
  - Intersection Sight Distance: (See Case F, [EXHIBIT 4.4c](#))
  - Lane Change & Deceleration Lane Length: (See [EXHIBIT 4.27](#) of this chapter)
  - Taper Rate from Expressway: 15:1 (See Section 1.D.2 of this chapter)
  - Storage Lane Length: Coordinate with **Traffic Engineering** (100 foot minimum, see Section 1.D.1 of this chapter)

#### **Right Turns from the Minor Road**

- See [EXHIBIT 4.4](#) and Section 1.D of this chapter
  - Number of Turn Lanes: One (based on low traffic volumes).
  - Angle of Approach: 90 degrees to the expressway (possibly a slight right-hand skew of the turn lane, coordinate with **Traffic Engineering**)
  - Intersection Sight Distance: (See Case B-2, [EXHIBIT 4.4b](#))

### Median U-Turns/Crossover

- **Design Speed:**
  - Approach to U-Turn: 9 to 14 mph
  - U-Turn: 10 mph
- **Crossover Spacing:** 600 to 1,000 feet from intersection to the U-turn, see [EXHIBIT 4.3](#) (design of the turn lanes may dictate the overall spacing)
- **Total Length:** Depends on the crossover spacing (from crossover to crossover)
- **Median Width:**
  - Desirable: 54 feet
  - Minimum: Existing (a narrow median impacts the turn speed, U-turn opening, and Loon dimensions)
- **Lane Change & Deceleration Lane** (See [EXHIBIT 4.3](#)):
  - Beginning Location: Coordinate with **Traffic Engineering** (tied to weaving analysis)
  - Taper Rate from Expressway: 15:1 (See Section 1.D.2 of this chapter)
  - Length: See [EXHIBIT 4.27](#)
  - Cross-Section: 12 feet wide with a four-foot integral left shoulder past the raised median, if present, see [Channelization](#) below (dependent on median width and type)
- **Storage Lane:**
  - Length: Coordinate with **Traffic Engineering** (100 foot minimum, see Section 1.D.1 of this chapter)
  - Cross-Section: 12 feet wide with a four-foot integral left shoulder (dependent on median width and type)
- **Median U-Turn, Left-Turn to Expressway:**
  - Intersection Sight Distance: See Case B-1, [EXHIBIT 4.4a](#)
  - Geometrics (width and radius): Based on turn radius of a WB-67 (angle of U-Turn at 90 degrees to expressway)
- **Width:** Based on turn radius of a WB-67
- **Loon** (See [EXHIBITS 4.3 & 4.6](#)):
  - Geometrics (width and radius): Based on turn radius of a WB-67, construction of the Loon may require additional right-of-way.
  - The Loon includes a two-foot outside surfaced shoulder.

### Channelization

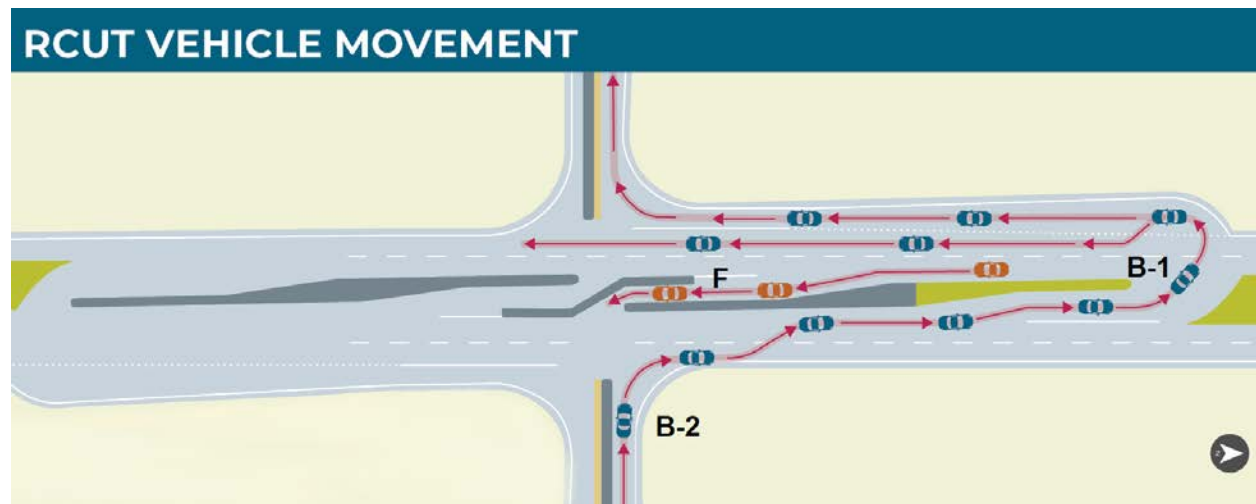
- **Left Turns from Expressway at Minor Road Intersection:**
  - Raised islands a minimum four-foot wide
- **Right Turns from Minor Road:**
  - Need: based on volumes, crash history (Coordinate with **Traffic Engineering**)
  - If needed: Raised median and/or islands, a minimum four-foot wide
- **Curbs:** Appropriate to the design speed (see Chapter Six: [The Typical Roadway Cross-Section](#), Section 3.B, of this manual)
- **Curb Clearance:** A three-foot minimum clear distance will be maintained between the outside tire edge of the design vehicle wheel path and the back of the outer curb

### Additional Design Considerations

- **Grades:** Grading impacts sight distance; if grading is impractical, signage may be required (Coordinate with **Traffic Engineering**)
- **Environmental Impacts**
- **Right-of-Way**
- **Access Control:** Expressways should have existing Access Control within the project limits
- **Utilities**
- **Drainage:** Maintain existing patterns and ditch width(s), may need to include inlets where they currently don't exist
- **Lighting:** Typically, from Loon to Loon; coordinate with the **ITS/Lighting Unit** in **Roadway Design**
- **Signing/Pavement Markings/Candlestick Delineators:** Coordinate with **Traffic Engineering**
- **ADA/Pedestrian Crossings:** Not likely but possible at Suburban/Rural Town (see Chapter Six: Pedestrian and Bicycle Facilities, Section 6, of this manual)
- **Bicycles:** Not likely but possible if on bike route and/or at Suburban/Rural Town (see Chapter Six: Pedestrian and Bicycle Facilities, Section 3, of this manual)
- **Design Vehicles:** Farm equipment can navigate the intersection via the Loon, emergency vehicles typically experience no additional time in traversing the intersection

For additional information see Section 9.9.4, "Wide Medians with U-Turn Crossover Roadways" and Section 9.9.5, "Location and Design of U-Turn Median Openings", in Chapter 9 of the *Green Book* (Ref. 4.1). Additional guidance available to the designer includes:

- **FHWA** publication Restricted Crossing U-Turn Intersection (<https://safety.fhwa.dot.gov/intersection/rltci/fhwasa14070.pdf>),
- Chapter Nine of the North Carolina Roadway Design Manual (<https://connect.ncdot.gov/projects/Roadway/Pages/Roadway-Design-Manual.aspx>),
- Minnesota DOT publication Best Practices for the Design and Operation of Reduced Conflict Intersections (<https://www.dot.state.mn.us/roadwork/rci/docs/bestpracticesfordesignandoperations.pdf>).



Intersection Sight Distance Left Turn from Stop on the Minor Road Case B-1, <i>Green Book</i> (Ref. 4.1), page 9-43			
Design Speed	Design Vehicle		
	WB-67 <sup>①</sup>	Single-Unit Truck <sup>②</sup>	Passenger Car <sup>③</sup>
55 mph	990 feet	825 feet	650 feet
60 mph	1075 feet	900 feet	705 feet
65 mph	1165 feet	975 feet	765 feet
70 mph	1255 feet	1050 feet	825 feet
75 mph	1345 feet	1125 feet	880 feet

Intersection Sight Distance is calculated using Equation 9-1 from the *Green Book*, page 9-45:

$$ISD = 1.47 V_{MAJOR} t_g$$

$V_{MAJOR}$  = Design Speed of major road (mph)

$t_g$  = time gap for minor road vehicle to enter the major road (sec)

Assumption: Turning vehicle is crossing two lanes of traffic to enter Loon

①  $t_g = 12.2$  sec (11.5 sec + 0.7 sec for additional lane, *Green Book Table 9-6*, page 9-44)

②  $t_g = 10.2$  sec (9.5 sec + 0.7 sec for additional lane, *Green Book Table 9-6*, page 9-44)

③  $t_g = 8.0$  sec (7.5 sec + 0.5 sec for additional lane, *Green Book Table 9-6*, page 9-44)

Note: "Furthermore, a departure sight triangle for left turns from the median roadway should be provided for the largest design vehicle that can be stored on the median roadway with adequate clearance to the through lanes." *Green Book*, page 9-47

**Exhibit 4.4a Intersection Sight Distances for a RCI  
 Case B-1, Left Turn from Stop on the Median to the Loon**

Intersection Sight Distance Right Turn from Stop on the Minor Roadway Case B-2, Green Book (Ref. 4.1), page 9-47			
Design Speed	Design Vehicle		
	WB-67 ①	Single-Unit Truck ②	Passenger Car ③
55 mph	850 feet	690 feet	525 feet
60 mph	925 feet	750 feet	575 feet
65 mph	1005 feet	815 feet	645 feet (SSD)
70 mph	1080 feet	875 feet	730 feet (SSD)
75 mph	1160 feet	940 feet	820 feet (SSD)

Intersection Sight Distance is calculated using Equation 9-1 from the *Green Book*, page 9-45:

$$ISD = 1.47 V_{MAJOR} t_g$$

$V_{MAJOR}$  = Design Speed of major road (mph)

$t_g$  = time gap for minor road vehicle to enter the major road (sec)

SSD = Stopping Sight Distance (*Green Book Table 9-9*, page 9-48). SSD will be used as the minimum condition when it exceeds the computed ISD.

①  $t_g = 10.5$  sec (*Green Book Table 9-8*, page 9-47)

②  $t_g = 8.5$  sec (*Green Book Table 9-8*, page 9-47)

③  $t_g = 6.5$  sec (*Green Book Table 9-8*, page 9-47)

**Exhibit 4.4b Intersection Sight Distances for a RCI  
Case B-2, Right Turn from Stop on Minor Road**

Intersection Sight Distance Left Turn from the Major Road Case F, Green Book (Ref. 4.1), page 9-56			
Design Speed	Design Vehicle		
	WB-67 ①	Single-Unit Truck ②	Passenger Car ③
55 mph	625 feet	540 feet	495 feet (SSD)
60 mph	680 feet	590 feet	570 feet (SSD)
65 mph	735 feet	645 feet (SSD for car)	645 feet (SSD)
70 mph	790 feet	730 feet (SSD for car)	730 feet (SSD)
75 mph	850 feet	820 feet (SSD for car)	820 feet (SSD)

Intersection Sight Distance is calculated using Equation 9-1 from the *Green Book*, page 9-45:

$$ISD = 1.47 V_{MAJOR} t_g$$

$V_{MAJOR}$  = Design Speed of major road (mph)

$t_g$  = time gap for minor road vehicle to enter the major road (sec)

SSD = Stopping Sight Distance (*Green Book Table 9-17*, page 9-57). SSD will be used as the minimum condition when it exceeds the computed ISD.

Assumption: Turning vehicle is crossing an additional four-foot median (.3333 equivalent lane)

①  $t_g = 7.7$  sec (7.5 sec + 0.2 sec for equivalent lane, *Green Book Table 9-16*, page 9-57)

②  $t_g = 6.7$  sec (6.5 sec + 0.2 sec for equivalent lane, *Green Book Table 9-16*, page 9-57)

③  $t_g = 5.7$  sec (5.5 sec + 0.2 sec for equivalent lane, *Green Book Table 9-16*, page 9-57)

Note: "Sight distance design should be based on a left turn by a stopped vehicle, since a vehicle that turns left without stopping would need less sight distance." *Green Book*, page 9-56

**Exhibit 4.4c Intersection Sight Distances for a RCI  
Case F, Left Turn from Expressway**

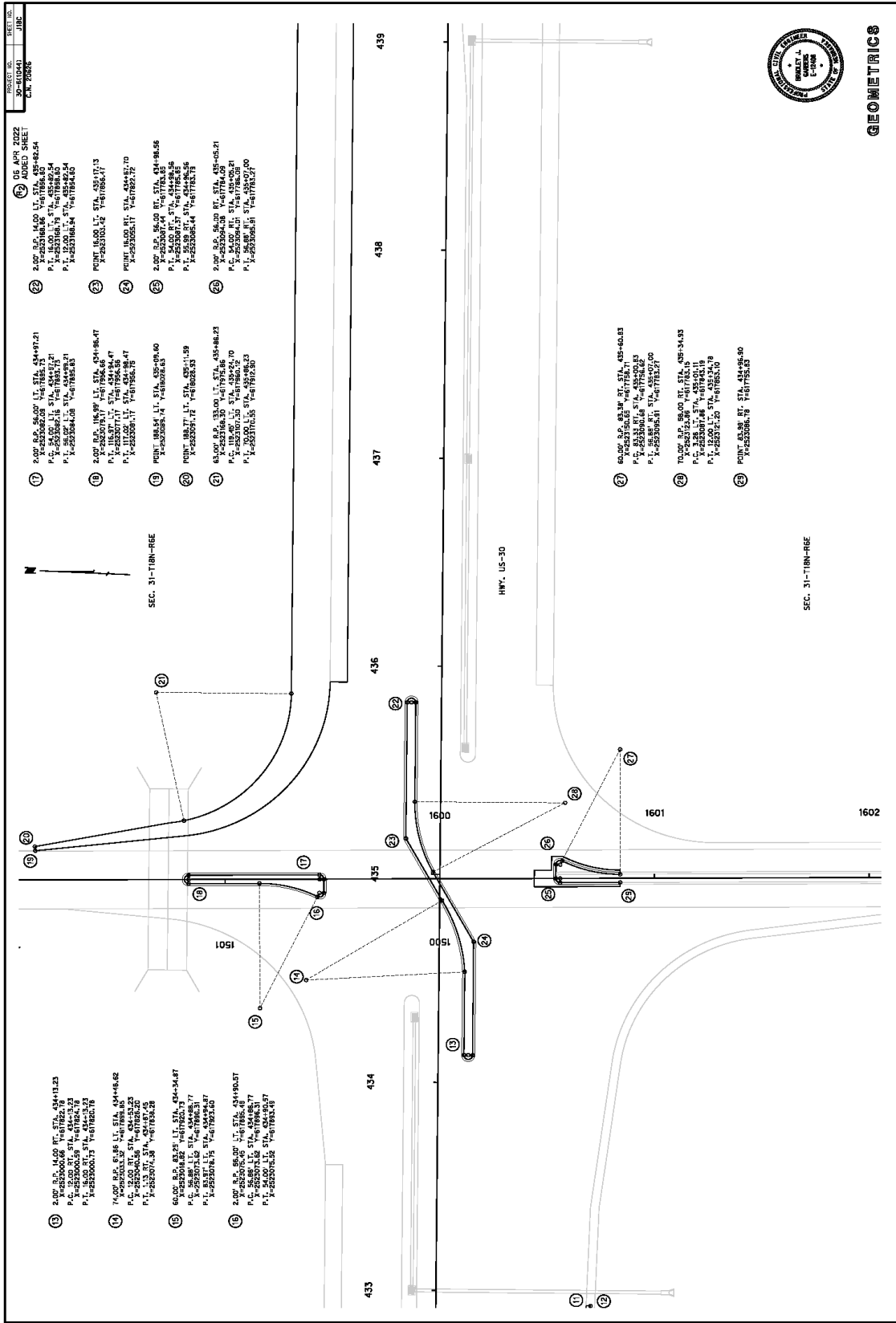
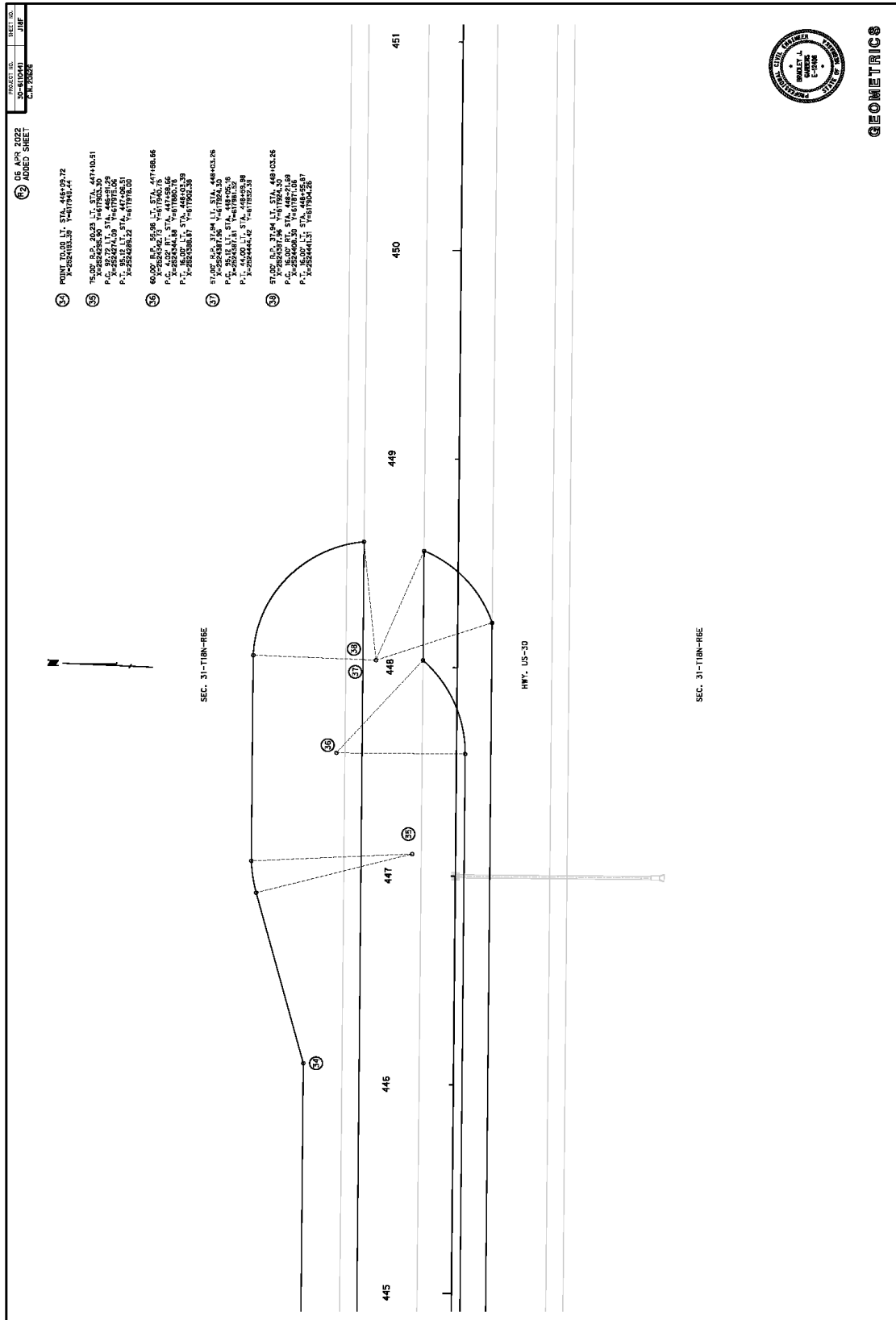


Exhibit 4.5 RCI Example Island Details



FILED 21558 GEOMETRICS SHAWNS.DWG 25-JUL-2022 08:12 C:\D\F\T1 500418\596 ROADWAY DESIGN DIVISION.

Exhibit 4.6 RCI Example Loon Details

## 1.B Intersection Locations

### 1.B.1 The Intersection of Two State Highways

The design of an intersection of two state highways requires coordination and input from the roadway designer, **District**, and **Traffic Engineering**. This team will address aspects of the intersection as they relate to each other, including but not limited to:

- The crash history
- The horizontal and vertical alignments
- Intersection drainage
- Signage
- Driver expectation
- Driver perception
- Approach visibility
- Proximity of access

The designer will alert **Traffic Engineering** of any changes to the intersection environment (the existing conditions and/or any changes throughout the design process). EXHIBIT 4.7 shows design guidance for the intersection geometry.



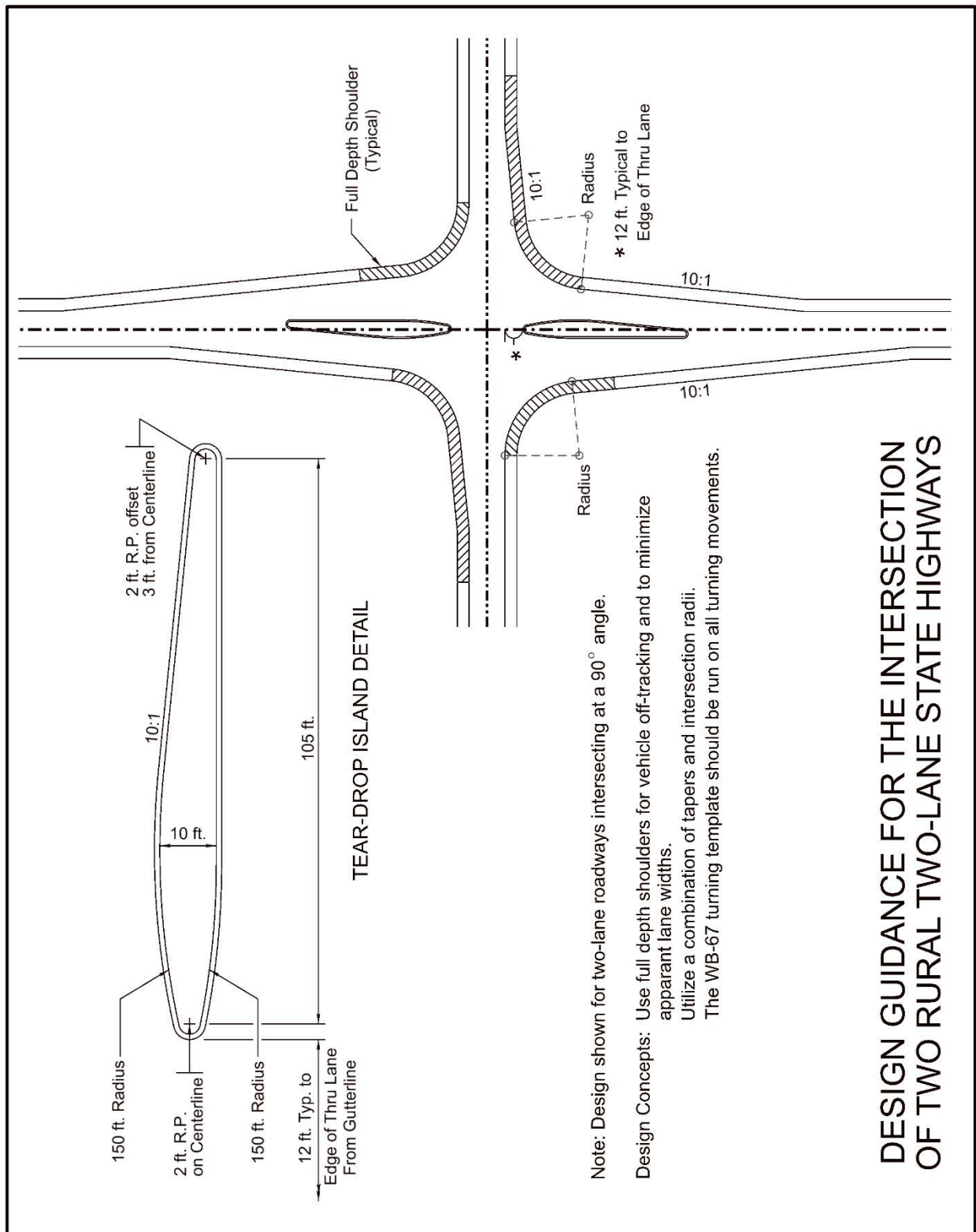


Exhibit 4.7 Design Guidance for the Intersection of Two Rural Two-Lane State Highways

### 1.B.2 Rural Intersections

A rural intersection often consists of the crossing of a low volume roadway with a higher type of roadway. The low volume roadway may carry agricultural equipment or other slow-moving, heavily laden vehicles across or onto the main roadway.

Topography plays a major role in the design of a rural intersection. The placement of an intersection within a length of roadway where the driver's sight distance is impaired should be avoided. If indicated by the crash history, the vertical and/or horizontal alignment should be investigated for the potential of increasing the intersection sight distance (See Section 1.C.2 of this chapter). When the location of an intersection is on a horizontal or vertical curve, **Traffic Engineering** may be consulted regarding the need to add auxiliary lanes to separate the through traffic from the turning traffic.

### 1.B.3 Urban Intersections

Due to existing development, there is limited opportunity for new intersection locations in urban areas; therefore, the design of most urban intersections must be coordinated with and tied to the geometry of the existing roadway system. Grades, lane widths, and intersection return radii should match those already present when no other options are available.

Urban intersection operation may be affected by:

- Traffic composition
- Significant directional traffic flow during peak periods
- Intersection spacing
- Adjacent intersection operation
- Mid-block traffic generators
- Pedestrian and/or bicycle traffic
- On-street parking

Sight distance at urban intersections may be obstructed by:

- The vehicle stop-line setback for pedestrian crosswalks
- Trees
- Fencing
- Signing
- Traffic signal control boxes
- Other development

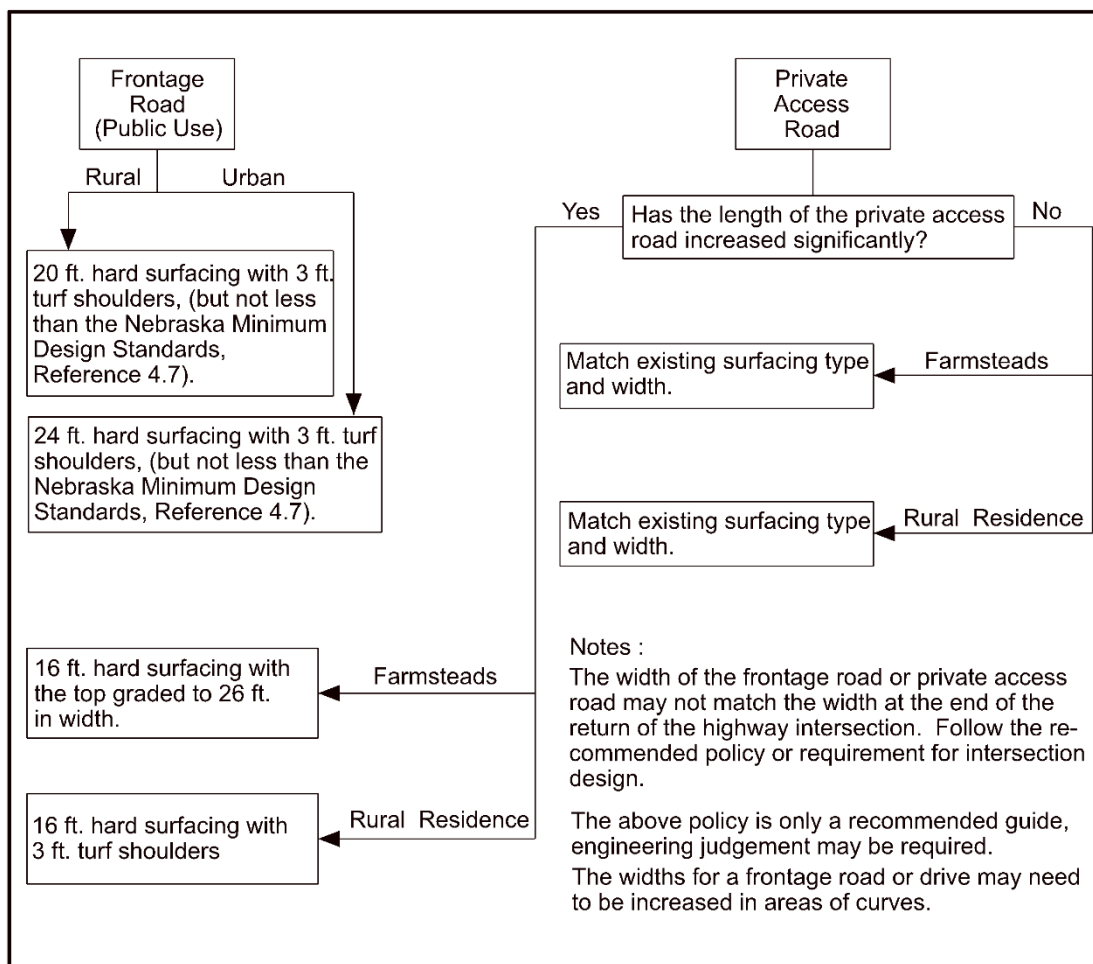
The design of urban intersection improvements should include field surveys to ascertain whether the desired intersection sight distance either currently exists or can be achieved (See Section 1.C.2 of this chapter).

**1.B.4 Frontage Roads**

The use of frontage roads allows the traffic capacity on the main roadway to remain at a higher level of service by combining driveway and/or minor roadway access locations into one intersection with the main roadway. In areas experiencing a transition from rural to urban character or from agricultural to commercial use, designers should anticipate possible future congestion and consider the addition of frontage roads.

Frontage roads can be designed to accommodate parking, transit services, and bicycle traffic for a developed corridor. The flow chart in EXHIBIT 4.8 should be used to determine the roadway widths of frontage and access roads. EXHIBIT 4.9 shows a typical frontage road connection off a major roadway.

If the frontage road intersects with a crossroad, the edge of the pavement of the frontage road should be a minimum distance of 220 feet from the edge of the through driving lane of the main roadway to provide sufficient distance for the development of left-turn lanes and for signing (See EXHIBIT 4.10). **Traffic Engineering** should be consulted to determine the actual distance required and to determine if traffic signals are warranted at the frontage road intersection based on the traffic volumes.



**Exhibit 4.8 Flow Chart for Roadway Widths of Frontage Roads and Access Roads**

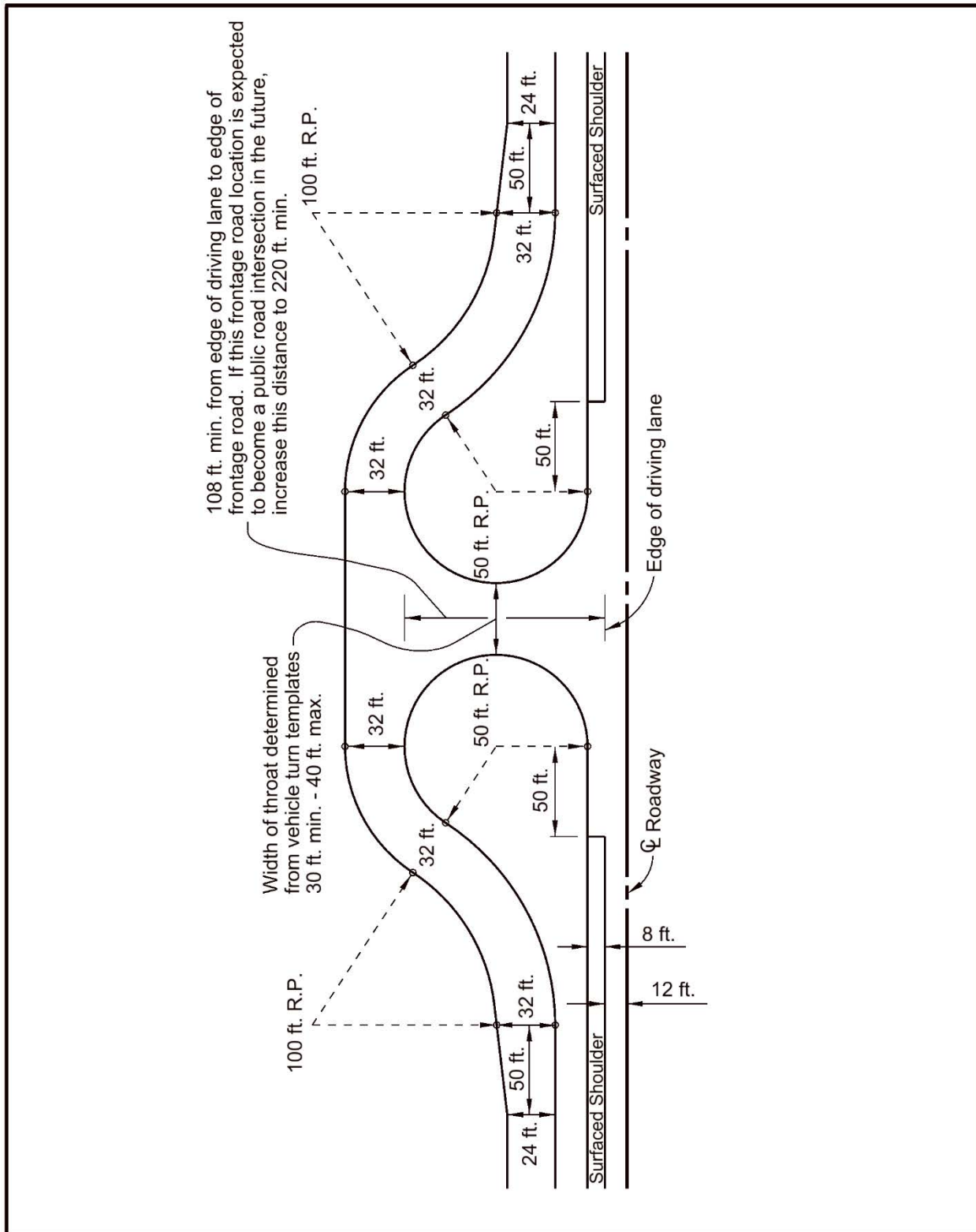
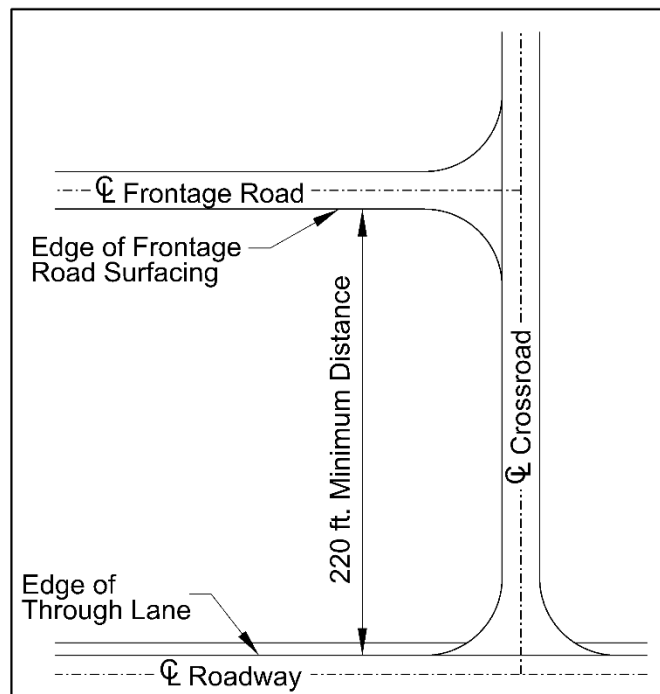


Exhibit 4.9 Typical Frontage Road Connection off of a Main Roadway



**Exhibit 4.10 Typical Frontage Road Connection off a Crossroad**

## **1.C Intersection Design Considerations**

### **1.C.1 Capacity and Level of Service**

The capacity of an intersection and the performance of the traffic flow passing through it vary considerably depending on the traffic controls used. Capacity analysis and the design of the intersection geometry should go hand-in-hand. **Traffic Engineering** performs capacity analysis with input from **Roadway Design**; **Roadway Design** in turn utilizes the capacity analysis results for the design of the intersection geometry.

### **1.C.2 Intersection Sight Distance**

Intersection sight distance consists of the provision of sight triangles along each leg of an intersection which are free of visual obstacles, giving a driver sufficient time and distance to avoid conflicts at the intersection (See **FIGURES 9-16 AND 9-17** of the *Green Book*, Ref. 4.1). For New and Reconstructed projects, the minimum stopping sight distance shall be provided on each leg of an intersection consistent with its design speed; intersection sight distance should be provided at unsignalized intersections (See Chapter Three: Roadway Alignment, EXHIBITS 3.9 & 3.14, of this manual for desirable sight distances).

The location of each intersection should be reviewed to identify sight restrictions. Intersections on New and Reconstructed projects should be designed for intersection sight distance for left-turns from a minor roadway based on a passenger car (Section 9.5.3.2.1, "Case B1 – Left-Turn from the Minor Roadway" in Chapter 9 of the *Green Book*, Ref. 4.1); **Assistant Design Engineer (ADE)** approval is required if this condition cannot be met. For additional information see So You Want Access to the Highway? (Ref. 4.17) (<https://dot.nebraska.gov/media/jeseiwu0/access-hwy.pdf>).

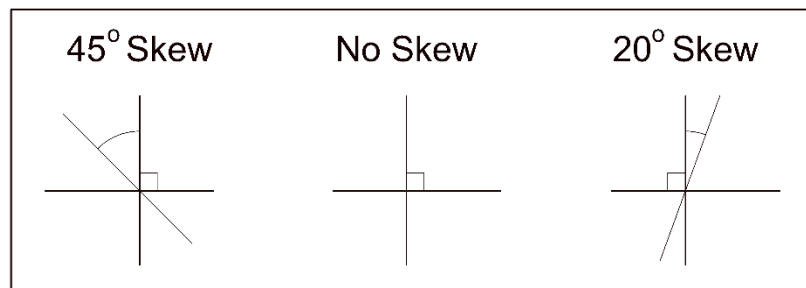
### 1.C.3 Horizontal Alignment

Desirably, all legs of an intersection will be on a tangent alignment; when roadways intersect on a horizontal curve, the design of the intersection geometry becomes significantly more complicated. Horizontal alignment at intersections requires special consideration of intersection sight distance, crash history, superelevation development, and other related factors. See Chapter Three: Roadway Alignment, Section 2, of this manual for additional information.

#### 1.C.3.a Intersection Skew w/Stop Control on Minor Roadway

Roadways should intersect at approximately 90°. A right-angle intersection provides a driver with the best conditions for judging the lane orientation and speed of vehicles on other approaches, provides a minimum distance for vehicles crossing through the intersection, and equalizes the turning maneuvers in all four quadrants.

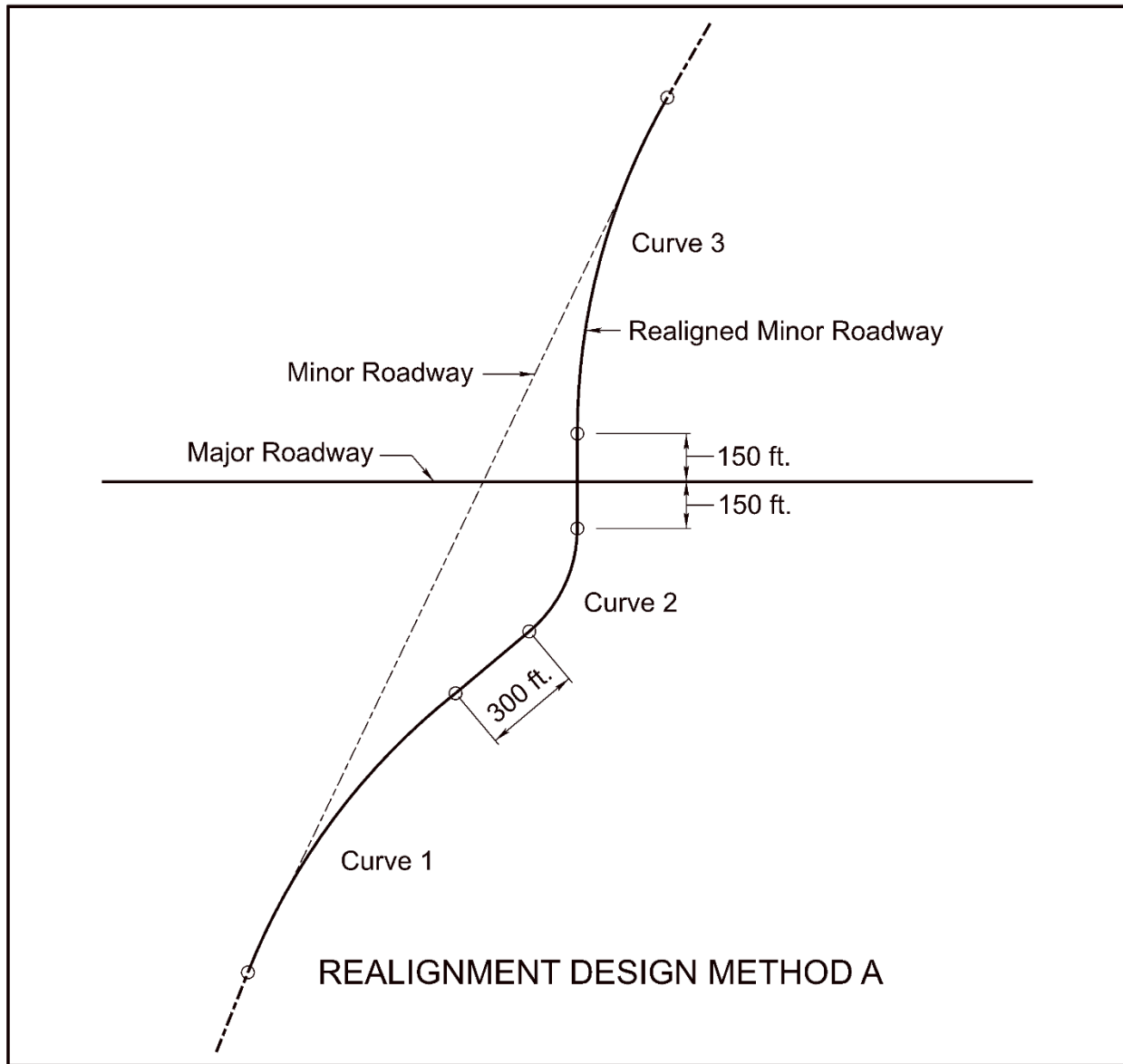
The intersection skew angle is defined as the degree of deviation from 90° (EXHIBIT 4.11). When designing New and Reconstructed projects, a skew of 15° or less is preferred. Use of a skew angle greater than 15° requires **Unit Head** approval, with input from **Traffic Engineering**. The allowable skew for 3R projects will be based on the recommendations from **Traffic Engineering** and on the crash history of the intersection.



**Exhibit 4.11 Skew Angle Definition**

Method A (See EXHIBIT 4.12) is used when there are excessive impacts on one side of the roadway (e.g. wetlands, buildings, grain elevators), Method B is the preferred intersection realignment; Methods C and D should only be used under very low volume conditions or, if in urban areas, where a minimum distance is provided between the offset intersections (**Traffic Engineering** may analyze the intersection configuration for left turn conflicts, etc. and will determine the minimum required distance). The dimensions and curve values given in EXHIBIT 4.12 are suggested design values only. The final design of the realignment requires **Roadway Design Unit Head (Unit Head)** approval.

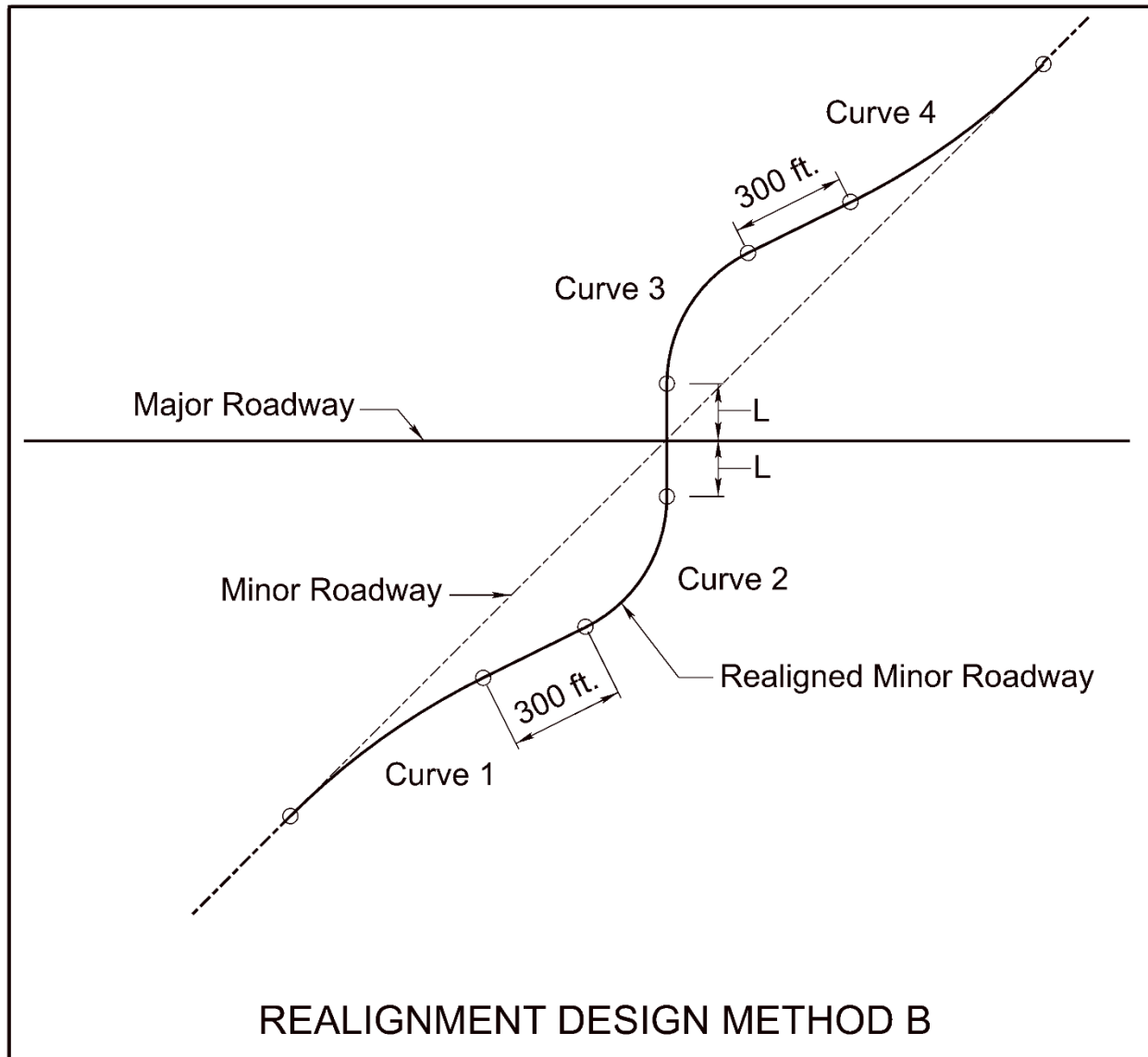
At intersection locations where the topography or where right-of-way impacts constrain intersection realignment, the designer should investigate the feasibility of realigning the intersection to the extent practicable.



Intersection Skew Angle	Curve 1			Curve 2			Curve 3		
	Radius Feet	Deflection Angle $\Delta$	Curve Length Feet	Radius Feet	Deflection Angle $\Delta$	Curve Length Feet	Radius Feet	Deflection Angle $\Delta$	Curve Length Feet
20°	1910	20°	667	382	40°	267	1910	20°	667
30°	1910	30°	1000	382	60°	400	1910	30°	1000
45°	1910	45°	1500	382	90°	600	1910	45°	1500

Note: Dimensions and curve values shown above are suggested design values. The final design of the realignment requires **Unit Head** approval.

**Exhibit 4.12a Intersection Realignment Design Method A**

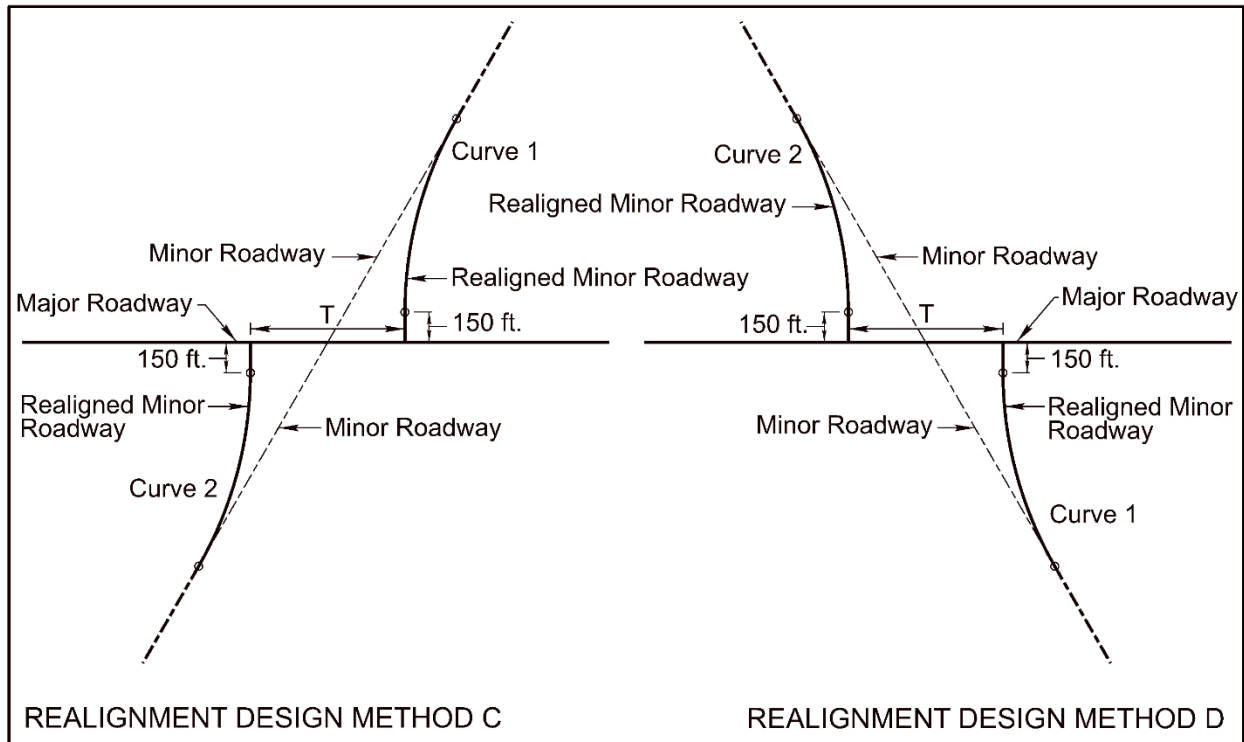


Intersection Skew Angle	L Feet	Curves 1 and 4			Curves 2 and 3		
		Radius Feet	Deflection Angle $\Delta$	Curve Length Feet	Radius Feet	Deflection Angle $\Delta$	Curve Length Feet
20°	150	1910	9°	300	382	29°	193
30°	150	1910	13°	433	382	43°	287
45°	150	1910	18.75°	625	382	63.75°	425
60°	155	1910	24.25°	808	382	84.25°	562

Note: Dimensions and curve values shown above are suggested design values. The final design of the realignment requires **Unit Head** approval.

**Exhibit 4.12b Intersection Realignment Design Method B**





Intersection Skew Angle	T Feet	Curve 1			Curve 2		
		Radius Feet	Deflection Angle $\Delta$	Curve Length Feet	Radius Feet	Deflection Angle $\Delta$	Curve Length Feet
20°	354	1910	20°	667	1910	20°	667
30°	764	1910	30°	1000	1910	30°	1000
45°	1882	1910	45°	1500	1910	45°	1500
60°	4339	1910	60°	2000	1910	60°	2000

Note: Dimensions and curve values shown above are suggested design values. The final design of the realignment requires **Unit Head** approval.

Exhibit 4.12c Intersection Realignment Design  
 Methods C and D

### 1.C.3.b Intersections on Curved Alignments

When a minor roadway intersects a mainline roadway which is on a horizontal curve, the minor roadway should be realigned to provide as close to a 90° intersection to the local tangent of the mainline curve as possible. Intersection sight distance should be investigated if the curve of the roadway may cause an unacceptable line of sight or cause the driver to have to look too far back over his/her shoulder (especially the right shoulder) to see oncoming traffic.

An intersection on a curved roadway alignment requires additional design consideration. The superelevation rate for state highways at intersections with other public roads is desirably 4% or less.

Research by the University of Nebraska, “Appropriate Design Speed for Horizontal Curves Approaching a Stop” (Ref. 4.4), shows that the running speed on a curve approaching a stop sign decreases to 45 mph at approximately 400 feet from the stop sign. The superelevation of stop-controlled approaches on curved alignments within this distance should be transitioned from the full superelevation at the PC to the superelevation at the PT (based on the appropriate speed and curve radius) throughout the remainder of the curve to allow vehicles to retain control during slowing and stopping. A short tangent section should be provided on the approach to the intersection. For further information regarding horizontal alignment, see Chapter Three: Roadway Alignment, Section 2, of this manual. For further discussion of intersection realignment, see the “Guidelines for Realignment of Skewed Intersections” (Ref. 4.8).

### 1.C.4 Profile

The profile gradient through an intersection must reflect the practicalities of matching the basic profiles of the intersecting roadways. The gradients of intersecting highways should be as flat as possible, with a consistent gradient through the intersection to facilitate traffic turning movements and to minimize the chance of stopping vehicles from sliding onto the mainline roadway when the pavement is wet or icy.

Appreciable changes in the design roadway elevation at intersections with existing crossroads and driveways should take into consideration the extent of reconstruction that will be required along the crossroad or driveway to match the elevation of the new alignment profile. A profile that results in excessive grades for side roads and driveways is not a desirable design. Adjustment to the profile of an existing crossroad will meet either the published standards of the appropriate city/county or the Nebraska Minimum Design Standards (MDS) (Ref. 4.7) (<https://dot.nebraska.gov/media/1z1n5kmb/nac-428-rules-regs-nbcs.pdf>), whichever is more stringent.

Consideration should be given to the placement of intersections and driveways with respect to vertical curves. When an intersection or a driveway must be placed on a crest vertical curve, it should be placed as near to the crest as possible. When an intersection or driveway is located slightly past the crest, inadequate sight distance may be a problem for both the motorist approaching on the minor roadway or driveway who cannot see oncoming mainline traffic and for motorists on the major roadway who cannot see the intersection or driveway. Where practicable, the PIs of crest vertical curves should be located at or near the intersection of the roadway centerlines. Chapter Three: Roadway Alignment, Section 3.C, discusses design controls for crest vertical curves.

### 1.C.5 Design Vehicle

A design vehicle is defined by the **Institute of Transportation Engineers** as “the vehicle that must regularly be accommodated on a thoroughfare without encroachment into other travel lanes”. The dimensions and operating characteristics of the design vehicle are used to establish highway design controls, such as the intersection or driveway radius. Selection of a design vehicle is influenced by the roadway type and the traffic composition. In selecting the appropriate design vehicle, the designer should keep in mind periodic usage of the intersection or driveway, such as the prevalence of large trucks at a grain elevator during harvest. [EXHIBIT 4.13](#) gives the **NDOT** minimum design vehicle to be used under various intersection conditions. For additional information see the *Green Book* (Ref. 4.1), Section 2.8, “Design Vehicles” in Chapter 2. Examples of minimum path turning templates are shown in **FIGURES 2-10** through **2-32** of the *Green Book* (Ref. 4.1).

INTERSECTING HIGHWAY OR ROADWAY	MINIMUM DESIGN VEHICLE *
INTERSTATE/RAMP TERMINALS	WB-67
EXPRESSWAY/MAJOR ARTERIALS	WB-67
LOCAL ROADS/COUNTY ROADS/FRONTAGE ROADS	S-BUS 36
RESIDENTIAL/LOCAL STREETS	SU OR P
COMMERCIAL DRIVE/FARM EQUIPMENT DRIVE	SU
PRIVATE ROAD/FARM DRIVE/RESIDENTIAL DRIVE	P

\* Use for design of intersection/drive geometry only, not to be used in the calculation of intersection sight distance. The use of a design vehicle smaller than the minimum listed in the table requires **Unit Head** approval.

#### Exhibit 4.13 Guidelines for the Selection of Intersection/Driveway Design Vehicles

### 1.C.6 Intersection Radius

- Urban intersections should have a minimum radius of 30 feet for 90° intersections.
- Rural intersections should have a minimum radius of 50 feet for 90° intersections.

The design of an intersection radius should be based on turning path templates of the selected design vehicle. These templates indicate wheel paths under ideal conditions; allowances should be made to provide a margin of error on the part of the driver.

A computer turning template program, such as *AutoTURN*<sup>®</sup>, may be used to determine the intersection geometry. A graphical procedure may also be used to determine the minimum intersection radius by placing the selected vehicle turning template on the intersection plan. To fit the WB-67 turning template, a combination of circular arc and short tapers may be the best solution (See [EXHIBIT 4.7](#)).

The minimum allowable distance between the edge of the full depth pavement and the outside edge of the tires of the turning design vehicle is two feet inside the edge of the full-depth pavement; the desirable distance is three feet.

### 1.C.6.a Left Turn Radii

A typical at-grade intersection does not have a continuous edge of pavement delineating the left turning path; the motorist has a guide at the beginning and at the end of the left turn movement provided by pavement markings or channelization. In some instances, pavement markings are provided to guide turns through wider intersections.

The design values for left turn radii are a function of the:

- Design vehicle
- Angle of intersection
- Number of lanes
- Median width

Left turn radii should be larger than required by the minimum design vehicle since the turning radius is based on a 10-mph operating speed and this speed can often be exceeded in actual operations. For roadways intersecting at right angles, left turn radii that range between 60 feet and 75 feet will normally satisfy all the controlling factors. For dual turning movements a minimum radius of 90 feet should be applied to retain a satisfactory capacity in the outer lane.

### 1.C.7 On-Street Parking

On-street parking in the immediate vicinity of an intersection may obstruct the driver's line of sight, impede traffic flow, and contribute to the crash potential. Parking should not be placed within 20 feet of the intersection crosswalk of any unsignalized intersection (See **Figure 3B-21** of the *MUTCD*, Ref. 4.2); parking near signalized intersections will be controlled by the requirements for dedicated turn lanes. See Chapter Ten: Miscellaneous Design Issues, Section 14, of this manual for additional information.

### 1.C.8 Transit Services

Urban intersections which are on bus routes should be designed to coordinate the operation of bus turnouts with the movement of through traffic. The designer will consult with **Traffic Engineering** regarding the location and length of the bus turnout, which may be placed on the near side or far side of the intersection. **NDOT** prefers the far side for signalized intersections. In either case, bus service may interfere with the intended operation of an intersection. Bus turnouts, merging tapers, and/or passenger loading space of sufficient length to accommodate the maximum number of buses anticipated at any given time should be provided, if practicable, to minimize interference with intersection operation. For additional information see Section 4.19, "Transit Facilities", in Chapter 4 of the *Green Book* (Ref. 4.1).

### 1.C.9 Signs

The placement of signs at or near an intersection shall be in accordance with the *MUTCD* (Ref. 4.2) and with the *NE-MUTCD* (Ref. 4.3). The designer will coordinate the design of the typical section and the geometry of the approach roadway with **Traffic Engineering** to allow for proper sign placement. The designer should also verify that intersection sight distance is not compromised either by the nature or the number of signs to be installed (or already in place).

### 1.C.10 Pedestrian Crosswalks

Curb ramps shall be constructed or reconstructed to meet the guidance found in the [Accessibility Guidelines for Pedestrian Facilities in the Public Right-of-Way \(2023\)](#) (*Accessibility Guidelines*) Ref. 4.9, (<https://www.federalregister.gov/documents/2023/08/08/2023-16149/accessibility-guidelines-for-pedestrian-facilities-in-the-public-right-of-way>) on all projects, as required. For further information, see Chapter Sixteen: [Pedestrian and Bicycle Facilities](#), Section 7; Chapter Seventeen: [Resurfacing, Restoration and Rehabilitation \(3R\) Projects](#), Section 16; and Chapter Fourteen: [Traffic](#), Sections 1.H and 4.A of this manual. For pedestrian design at roundabouts, see Chapter 6 of NCHRP Report 672, "Roundabouts: An Informational Guide", Second Edition (Ref. 4.18).

### 1.C.11 Bike Lane - Highway Intersections

Bike lane design at intersections should allow both motorists and bicyclists to operate following normal rules of the road with a minimum of confusion. Intersections without bike lanes but with significant bicycle traffic may require additional traffic control study. Refer to Chapter Sixteen: [Pedestrian and Bicycle Facilities](#), Section 4, and the [Guide for Development of Bicycle Facilities](#) (Ref. 4.10), ([https://safety.fhwa.dot.gov/ped\\_bike/docs/b\\_aashtobik.pdf](https://safety.fhwa.dot.gov/ped_bike/docs/b_aashtobik.pdf)) for additional information. For bike lane design at roundabout intersections, see Chapter 6 of NCHRP Report 672, "Roundabouts: An Informational Guide", Second Edition (Ref. 4.18).

### 1.C.12 Railroad Crossings

Railroad crossing design must consider approach grades, sight distance, drainage, highway traffic volumes, and the frequency of train movements. See Section 3.A of this chapter and Chapter Ten: [Miscellaneous Design Issues](#), Section 1, for information regarding railroad-highway grade crossings.

### 1.D Turn Lanes

When **Traffic Engineering** has determined that specific turning movements should be separated from through movements, they will recommend that a turn lane be added to the project. While the use of a turn lane may increase the capacity of an intersection, roadway widening for turn lanes may require additional right-of-way and could impact adjacent properties, drainage patterns, and driveway operations in the vicinity of the intersection.

**Traffic Engineering** may recommend right turn lanes, offset right turn lanes, free flow right turn lanes, or left turn lanes as warranted (See [EXHIBITS 4.14 & 4.16](#)). See Chapter 9 of the *Green Book* (Ref. 4.1) for additional discussion.

A right turn lane may be recommended for the following reasons:

1. To serve right turn vehicles which are required to slow for the turn movement, alleviating delays to arterial traffic and reducing the potential for rear-end crashes.
2. To move the stop bar position back on the minor approach, widening the throat entry for left turning vehicles from the arterial roadway. This serves to provide better visual “targeting” for the driver, aid larger vehicles to avoid edge drop-off, and reduce turning time which reduces the through lane clearance time requirements.

Right-turn lanes on rural, high-speed ( $\geq 50$  mph), non-signalized roadways should be offset (See Section 1.D.3 of this chapter).

Shoulders adjacent to 12-foot-wide right turn lanes should be four feet in width when surfaced, with an additional two-foot turf transition, and two feet in width when turf.

Left turn lanes should be provided on the mainline at signalized intersections, if warranted. The following situations may necessitate the addition of an exclusive left turn lane:

- Where fully protected left turn signal phasing is to be provided
- Where left turn volumes exceed 100 vph and space is available
- Where left turn volumes exceed 300 vph, dual left turn lanes should be considered

Left turn lanes may be necessary on two-lane highways where traffic volumes are high.

Left turn lanes should be provided on divided arterial routes at intersections and at other median breaks where left turn volumes and/or vehicle speeds are high. To reduce the obstruction of the line of sight by opposing traffic, the left turn lanes in 18 feet wide raised medians should be designed with a one-foot offset. Wide striping on the right side of the left turn lane should be used to encourage traffic to move closer to the median (See [EXHIBIT 4.15](#)).

Two-way left turn lanes (TWLTL) have been constructed in urban areas in lieu of raised medians. **Traffic Engineering** will determine when TWLTL treatment is appropriate. TWLTL treatments provide the advantages of:

- Reduced travel time
- Improved capacity
- Ability to use the TWLTL as a travel lane during closure of a through lane
- Wide acceptance from abutting property owners

Providing a TWLTL may be preferable to having vehicles make U-turns at intersections or traveling around the block to reach a destination. Median widths of 12 feet to 16 feet wide are most adaptable to TWLTL conversion.

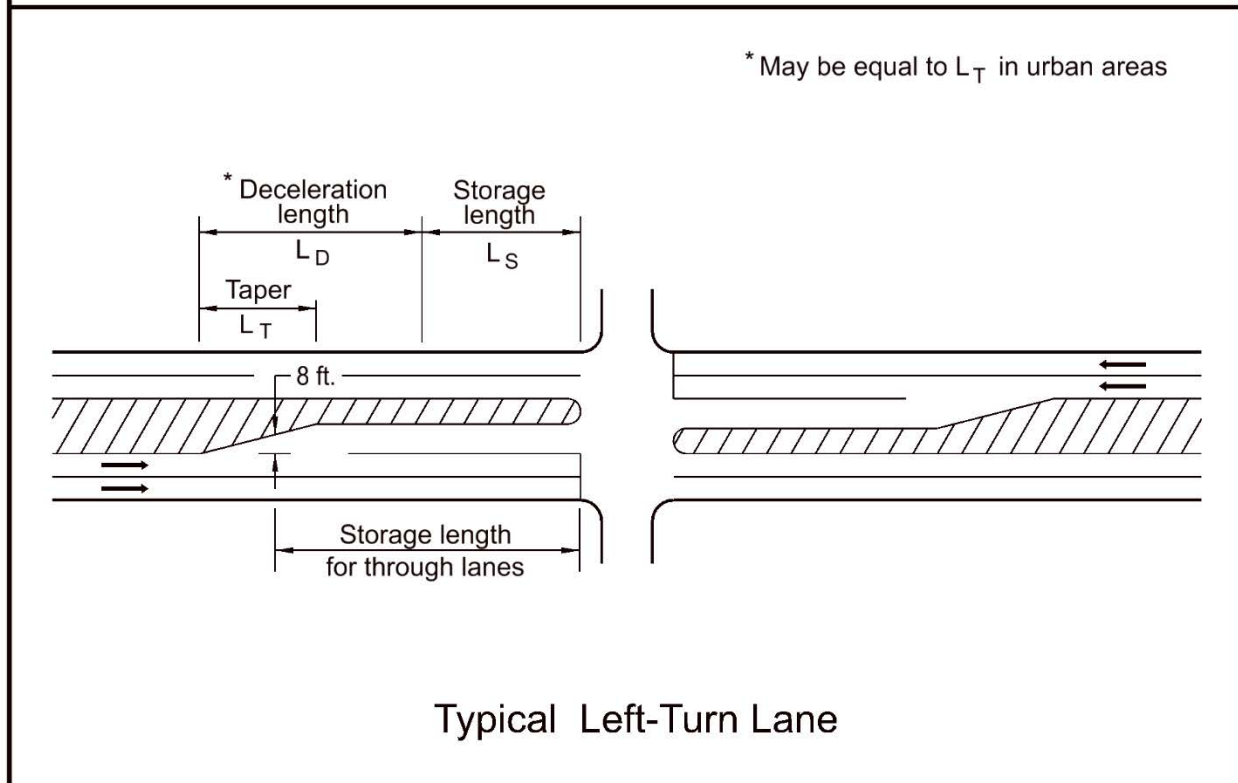
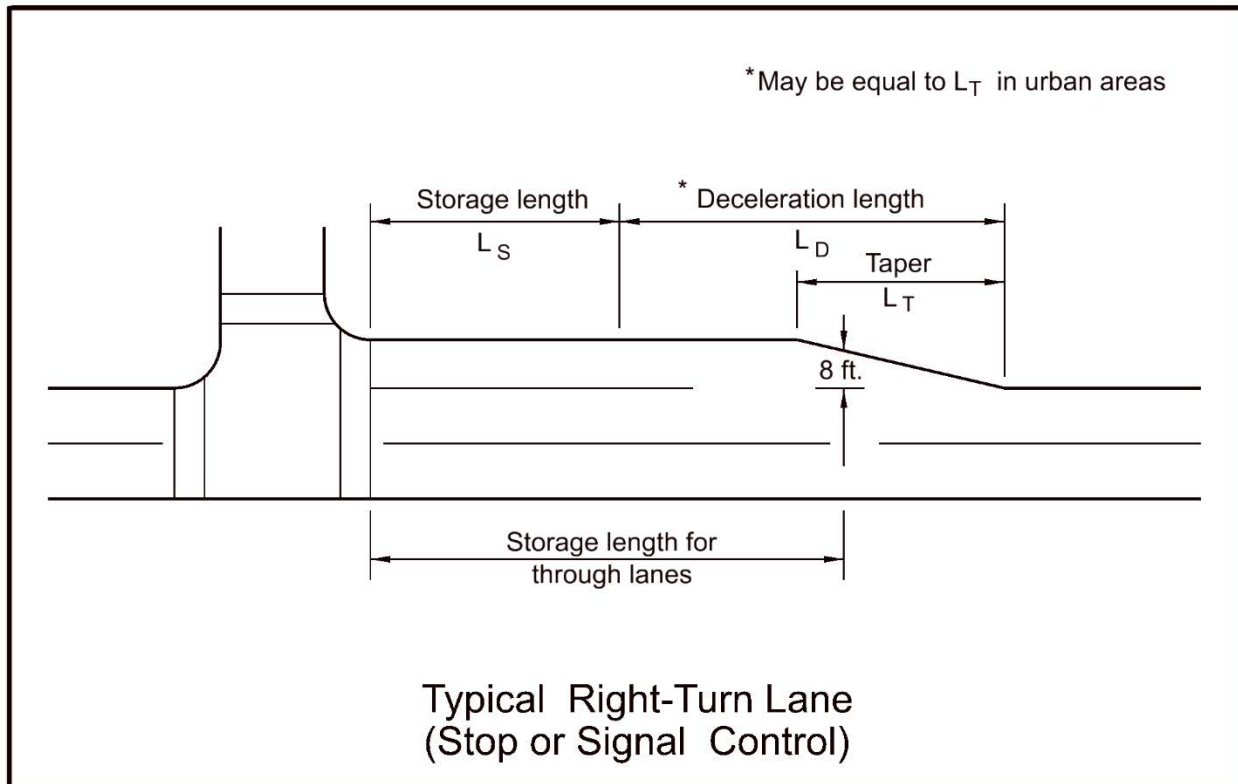


Exhibit 4.14 Typical Auxiliary Lanes

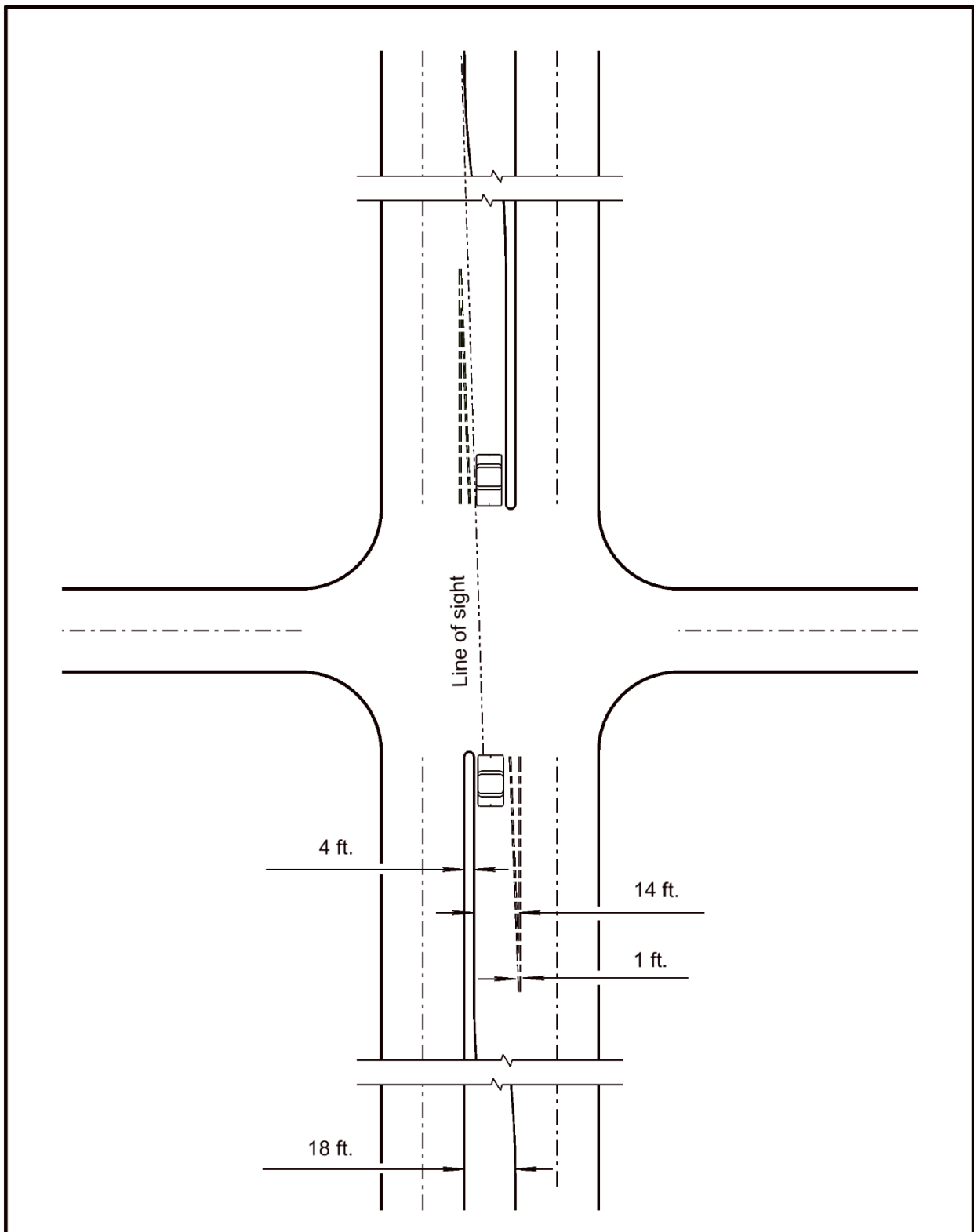


Exhibit 4.15 18 Foot Median, Left-Turn Lane



### 1.D.1 Turn Lane Length

Turn lane length is a function of the:

- Through traffic volumes
- Turning traffic volume
- Required storage length
- Approach design speed
- Length required to decelerate from the approach design speed to a stop  
And
- Type of intersection control

Turn lane length has three components:

- Entering taper
- Deceleration length
- Storage length

Sufficient deceleration length should be provided to allow motorists to slow from the highway design speed to a comfortable stop, based on a comfortable deceleration rate of 6.5 ft./sec.<sup>2</sup> (See [EXHIBIT 4.28](#)). In urban areas with lower design speeds and more closely spaced intersections, it may not be feasible to provide the entire deceleration length. In these locations some deceleration may occur prior to entering the auxiliary lane.

The storage length should provide sufficient space so that neither turning nor through traffic blocks the other. A minimum length of 50 feet (storage space for two passenger cars) should be provided on urban and suburban streets with speeds  $\leq$  35 mph. A minimum 100 ft. of storage should be provided for high-speed urban and suburban streets ( $\geq$  40 mph) and on rural roadways. The roadway designer will consult with **Traffic Engineering** to determine the recommended storage length at an intersection.

For additional information, see Chapter 9, Section 9.7.2, "Deceleration Lanes" and **Tables 9-21** and **9-22** in the *Green Book* (Ref. 4.1).

### 1.D.2 Turn Lane Bay Taper Rate

The entering turn lane bay taper rate should be 15:1 for rural high-speed roadways (design speed  $\geq$  50 mph) (See [EXHIBITS 4.25, 4.26, AND 4.29 THROUGH 4.42](#)); the turn lane bay taper length should equal the posted speed limit (at a minimum) for low-speed roadways (design speed  $\leq$  45 mph).

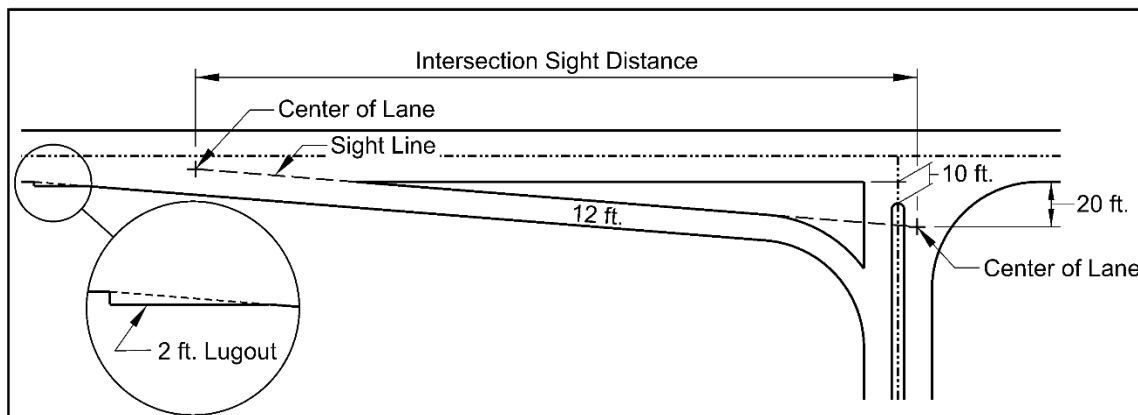
### 1.D.3 Offset Right-Turn Lanes

An offset right-turn lane is intended to provide an unobstructed sight triangle for the driver stopped on the minor road by providing a raised or painted island between the mainline roadway and the right-turn lane. An offset right-turn lane is generally used when recommended by **Traffic Engineering** or at the discretion of the **ADE**.

**NDOT** prefers the use of the tapered offset right-turn lane at unsignalized intersections on high-speed roadways ( $\geq 50$  mph) (See [EXHIBIT 4.16](#)). A parallel offset should be used when spillback off the crossroad is anticipated (e.g. a train track runs parallel to the mainline, a congested driveway is downstream of the intersection on the crossroad). **ADE** approval is required to design a parallel offset right-turn lane. The design guidance for an offset right-turn lane (two-lane and four-lane roadways) includes:

1. The median island on the minor road should be 10 feet from the edge of the through lane (face of curb to the edge of the traveled way), regardless of shoulder width and should extend down the side road beyond the turn lane.
2. Assume that the driver's eye is 20 feet from the edge of the nearest through lane.
3. Design the Intersection Sight Distance (ISD) for five mph over the posted or anticipated speed limit.
4. Design the intersection sight line to the left for the minor roadway design vehicle crossing the nearest lane, including four-lane roadways. On four-lane roadways double check that a vehicle in the near lane at the required ISD does not block a vehicle in the second lane over (far lane) at the required ISD.
5. Assume that the sight line is from the driver's eye to the middle of the nearest lane at the required ISD.
6. Place the outside of the tapered right-turn lane 12 feet outside of and parallel to this line.
7. Design a two-foot lugout from where the outside edge of the right-turn lane is two feet from the edge of the nearest driving lane.

For further information, see Chapter 9 of the *Green Book* (Ref 4.1), Section 9.5.3.2 and "Offset Right-Turn Lanes for Improved Intersection Sight Distance" (2010) (Ref. 4.19) ([Offset Right-Turn Lanes for Improved Intersection Sight Distance Final Report \(unl.edu\)](#)) and "Offset Right-Turn Lanes on State Highway Systems" (2018) (Ref. 4.20) ([m060-offset-right-turn-lanes.pdf \(nebraska.gov\)](#)).



Intersection Sight Distance Left Turn from Stop on the Minor Road Case B-1, <i>Green Book</i> (Ref. 4.1), page 9-43			
Left Turn Onto a Two-Lane Major Roadway			
Design Speed	Minor Road Design Vehicle		
	WB-67 <sup>①</sup>	Single-Unit Truck <sup>②</sup>	Passenger Car <sup>③</sup>
55 mph	955 feet	790 feet	625 feet
60 mph	1040 feet	865 feet	680 feet
65 mph	1130 feet	935 feet	735 feet
70 mph	1215 feet	1010 feet	790 feet

<sup>①</sup>  $t_g = 11.8$  sec (11.5 sec + 0.3 sec for additional 5.5 ft. setback, *Green Book* Table 9-6, page 9-44)

<sup>②</sup>  $t_g = 9.8$  (9.5 sec + 0.3 sec for additional 5.5 ft. setback, *Green Book* Table 9-6, page 9-44)

<sup>③</sup>  $t_g = 7.7$  (7.5 sec + 0.2 sec for additional 5.5 ft. setback, *Green Book* Table 9-6, page 9-44)

Intersection Sight Distance Left Turn from Stop on the Minor Road Case B-1, <i>Green Book</i> (Ref. 4.1), page 9-43			
Left Turn Onto a Four-Lane Undivided Major Roadway			
Design Speed	Minor Road Design Vehicle		
	WB-67 <sup>④</sup>	Single-Unit Truck <sup>⑤</sup>	Passenger Car <sup>⑥</sup>
55 mph	1010 feet	850 feet	665 feet
60 mph	1105 feet	925 feet	725 feet
65 mph	1195 feet	1005 feet	785 feet
70 mph	1285 feet	1080 feet	845 feet

<sup>④</sup>  $t_g = 12.5$  sec (11.8 sec (tg 2-lane) + 0.7 sec for additional lane, *Green Book* Table 9-6, page 9-44)

<sup>⑤</sup>  $t_g = 10.5$  (9.8 sec (tg 2-lane) + 0.7 sec for additional lane, *Green Book* Table 9-6, page 9-44)

<sup>⑥</sup>  $t_g = 8.2$  (7.7 sec (tg 2-lane) + 0.5 sec for additional lane, *Green Book* Table 9-6, page 9-44)

Intersection Sight Distance is calculated using Equation 9-1 from the *Green Book*, page 9-45:

$$ISD = 1.47 V_{MAJOR} t_g$$

$V_{MAJOR}$  = Design Speed of major road (mph)

$t_g$  = time gap for minor road vehicle to enter the major road (sec)

*Green Book* Setback = 14.5 ft. from the edge of the nearest through lane. **NDOT** Setback = 20 ft. from edge of the nearest through lane.

**Exhibit 4.16 Tapered Offset Right-Turn Lane**

#### 1.D.4 Turning Roadways at Intersections (Free-Flow Right Turn Lanes)

Based on the traffic counts and composition, **Traffic Engineering** may recommend the design of a turning roadway. Turning roadways are channelized right-turn lanes at intersections, providing free flow turn movements. The design of a turning roadway usually consists of a deceleration lane leading to a horizontal curve, providing a gradual speed reduction and a more natural turning path for the driver. For additional information see Section 3.3.11, “Widths for Turning Roadways at Intersections”, in Chapter 3 of the *Green Book* (Ref. 4.1).

#### 1.E Traffic Control

The purpose of traffic control is to regulate, warn, and guide traffic efficiently through intersections. Traffic control design is governed by warrants discussed in *MUTCD* (Ref. 4.2) and the *NE-MUTCD* (Ref. 4.3). Traffic control is the responsibility of **Traffic Engineering**.

There are four types of traffic control:

1. No control, where motorists must be able to see and evaluate the intersection and traffic situation in sufficient time to stop.
2. Yield control, where vehicles on the minor approach yield to vehicles on the major route; all vehicles yield to vehicles in a roundabout.
3. Stop control, where vehicles on either the minor or all approaches must stop prior to entering the intersection.
4. Signal control, where the approach legs of the intersection are controlled by a traffic signal.

**Traffic Engineering** conducts an engineering study to evaluate the operation of an intersection and to determine the appropriate traffic control to be provided. It is essential that the roadway designer coordinate with **Traffic Engineering** regarding roadway geometry, intersection capacity, and traffic operations (See Chapter Fourteen: Traffic of this manual).

Coordination with the **Rail Unit** in the **Local Assistance Division** is required where highway intersection signals are interconnected with rail-highway crossing signals (See Chapter Ten: Miscellaneous Design Issues, Section 1, of this manual).

See Section 9.11.2, “Traffic Control Devices” in Chapter 9 of the *Green Book* (Ref. 4.1), Part IV of the *MUTCD* (Ref. 4.2), and the *NE-MUTCD* (Ref. 4.3) for further discussion.

#### 1.E.1 Unsignalized Intersections

The simplest form of installed traffic control at an intersection is the use of a yield sign for the roadway having the lower traffic volume. As the traffic volume increases the minor street can be controlled by a stop sign. All roadway approaches at an intersection may be controlled with a four-way stop.

An unsignalized intersection does not normally require auxiliary lanes. The time required for each vehicle to accelerate and pass through an average intersection, after stopping or slowing to yield, is typically three to four seconds. When this delay increases (e.g. when truck traffic has limited opportunity to clear the intersection), as queues become commonplace for the minor roadway, and/or when a crash history is established as drivers take more risks to enter perceived gaps in traffic, the level of service of the intersection degrades. In these situations, **Traffic Engineering** may recommend the addition of auxiliary lanes to the intersection.

## 1.E.2 Signalized Intersections

Traffic signals usually provide more efficient traffic operation where large volumes of traffic must be accommodated by allocating time to specific traffic movements. Essentially, signalization moves vehicles in groupings or "platoons" to reduce delays caused by the starting and stopping of individual vehicles.

In urban areas with multiple signalized intersections, the designer must consider the progressive nature of traffic signal system coordination, where it is desirable to move vehicle platoons from one intersection to the next. Each succeeding intersection must be configured to handle the approach volumes and to store or channelize the required turning movements. The designer must coordinate with **Traffic Engineering** to verify that the proposed approach lanes and intersection design can accommodate the design year traffic volumes.

## 2. DRIVEWAYS

Access will be provided to all properties, but it may be from joint access locations, from side roads, or from frontage roads. When access locations are consolidated in rural areas, driveways on one side of the highway should be located opposite driveways on the other side of the highway. Access will conform to the Access Control Policy to the State Highway System (Ref. 4.12) (<https://dot.nebraska.gov/media/v45nhanu/access-control-policy.pdf>).

The designer should avoid an excessive number of entrances. Keep in mind that:

- Approaches are expensive
- Some existing field entrances may no longer be required
- Each driveway presents a potential conflict with highway traffic
- Each driveway could represent an obstruction in the recovery area

Recommendations for access locations should be made during the plan-in-hand inspection. If there is any question about the need for access, the situation should be investigated during the plan-in-hand or other field inspection.

Any proposed change of a field entrance or driveway location in a rural area will be coordinated with the **Right-of-Way Division (ROW)**. The proposed change will also be coordinated with the **Utilities Unit in Roadway Design (Utilities)** to verify that there are no utility conflicts. Location changes of urban driveways will be coordinated with **ROW**, **Utilities**, the **ITS/Lighting Unit**, and **Traffic Engineering**. Driveway locations should not change after the design plans have been submitted to **PS&E**.

For additional information see the Access Control Policy to the State Highway System (Ref. 4.12), and Chapter Fifteen: Right-of-Way, Section 3.

**2.A Rural Driveways**

The following guidelines should be referred to when designing field entrances and driveways in rural locations:

1. Check the project file and/or consult with the **Unit Head** for the requirements regarding access control on the project prior to locating or designing driveways (See Chapter Fifteen: Right-of-Way, Section 3).
2. To discourage wrong-way movement, rural access openings and driveways should not be located within 300 feet of a median opening unless the access opening or driveway is directly opposite the median opening.
3. Joint access to adjoining properties should be provided where practicable, the access opening should be centered on the property line. Joint access will usually require the purchase of permanent right-of-way easements (See Chapter Fifteen: Right-of-Way, EXHIBIT 15.1).
4. Driveways should be located at or near the crest of vertical curves. Driveways located past the crest of a vertical curve may not be visible to approaching traffic.
5. The maximum desirable grade for rural access openings is  $\pm 8\%$ . In a high cut or deep fill situation, a maximum grade of  $\pm 15\%$  is allowable.
6. The grade of the shoulder slope or flatter should be continued along the driveway for a minimum of 20 feet beyond the edge of the shoulder before breaking to a steeper slope.
7. On a project where the earthwork is measured in embankment, the earthwork required for the construction of the driveways and field entrances must be included in the earthwork totals (See Chapter Seven: Earthwork, Section 4.B.1, of this manual).
8. The provision of adequate driveway length to allow agricultural equipment to pull completely off of the roadway should be considered.
9. Inform the **Pavement Design Engineer** in **M&R** of any drives on a project which are expected to carry farm equipment; these drives may require thicker surfacing to support the heavier loads being supported.

Depending on the traffic volume and composition, driveways in rural locations may be considered as minor intersections and may include provisions for deceleration, turning movements, and acceleration.

EXHIBITS 4.18 & 4.19 show typical rural driveway designs. See EXHIBIT 4.17 for rural driveway design criteria. For additional information see Chapter Ten: Miscellaneous Design Issues, Section 10 “Mailbox Turnouts and Supports”, of this manual.

Driveway Type	Rural Driveway Width *		
	Residential Drive	Commercial Drive	Field Entrances
Single	Grade 26 feet Surface 24 feet R = 25 feet	Grade 42 feet Surface 40 feet R = 40 feet	Grade 26 feet R = 25 feet
Joint Use (Driveway on property line)	Grade 26 feet Surface 24 feet R = 25 feet	Grade 42 feet Surface 40 feet R = 40 feet	Grade 42 feet R = 25 feet

Notes: The width of the surfaced shoulder will not be subtracted from the driveway radius.

\* Measured at the throat of the driveway

**Exhibit 4.17 Rural Driveway Width Criteria**

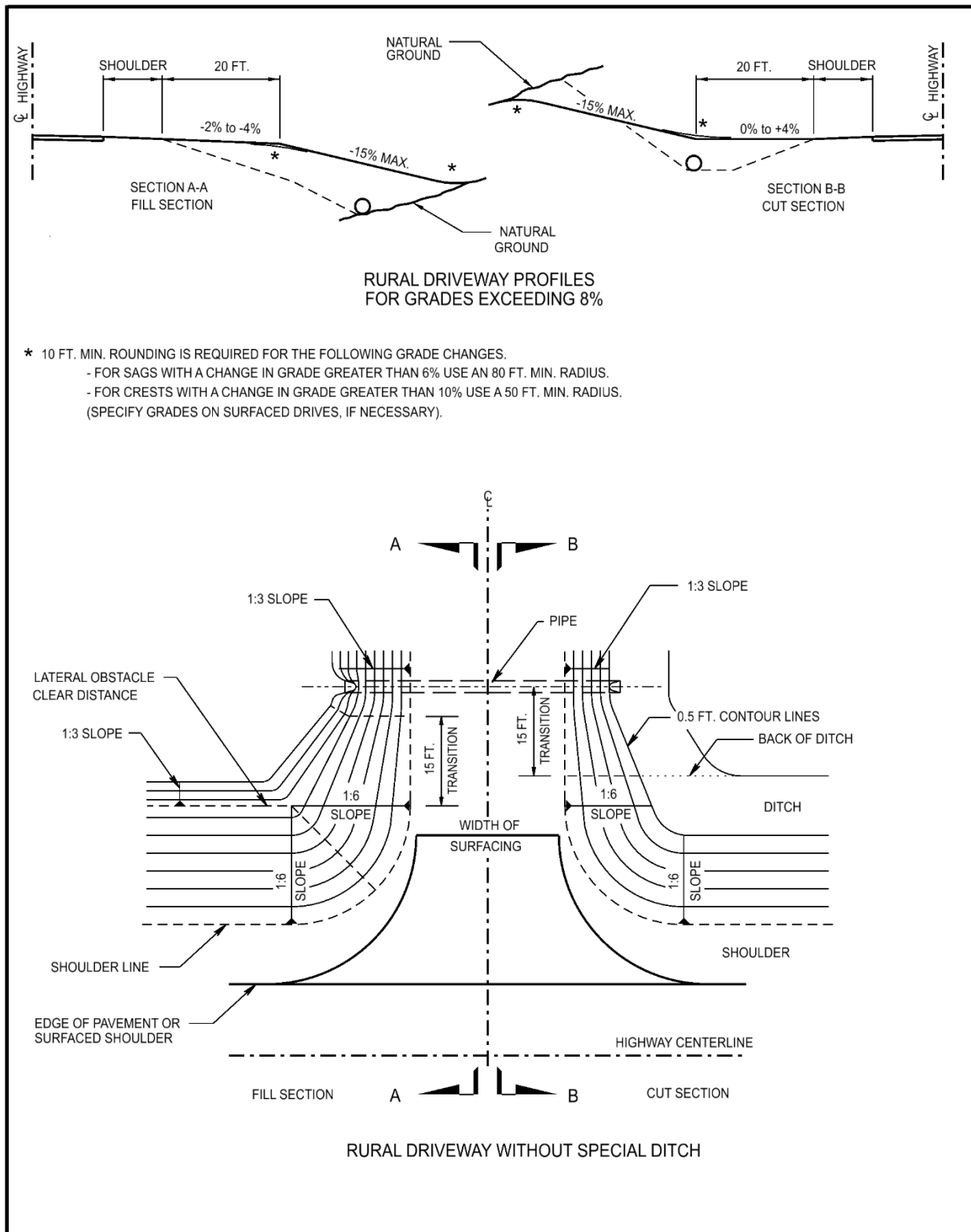


Exhibit 4.18 Rural Driveway Without a Special Ditch

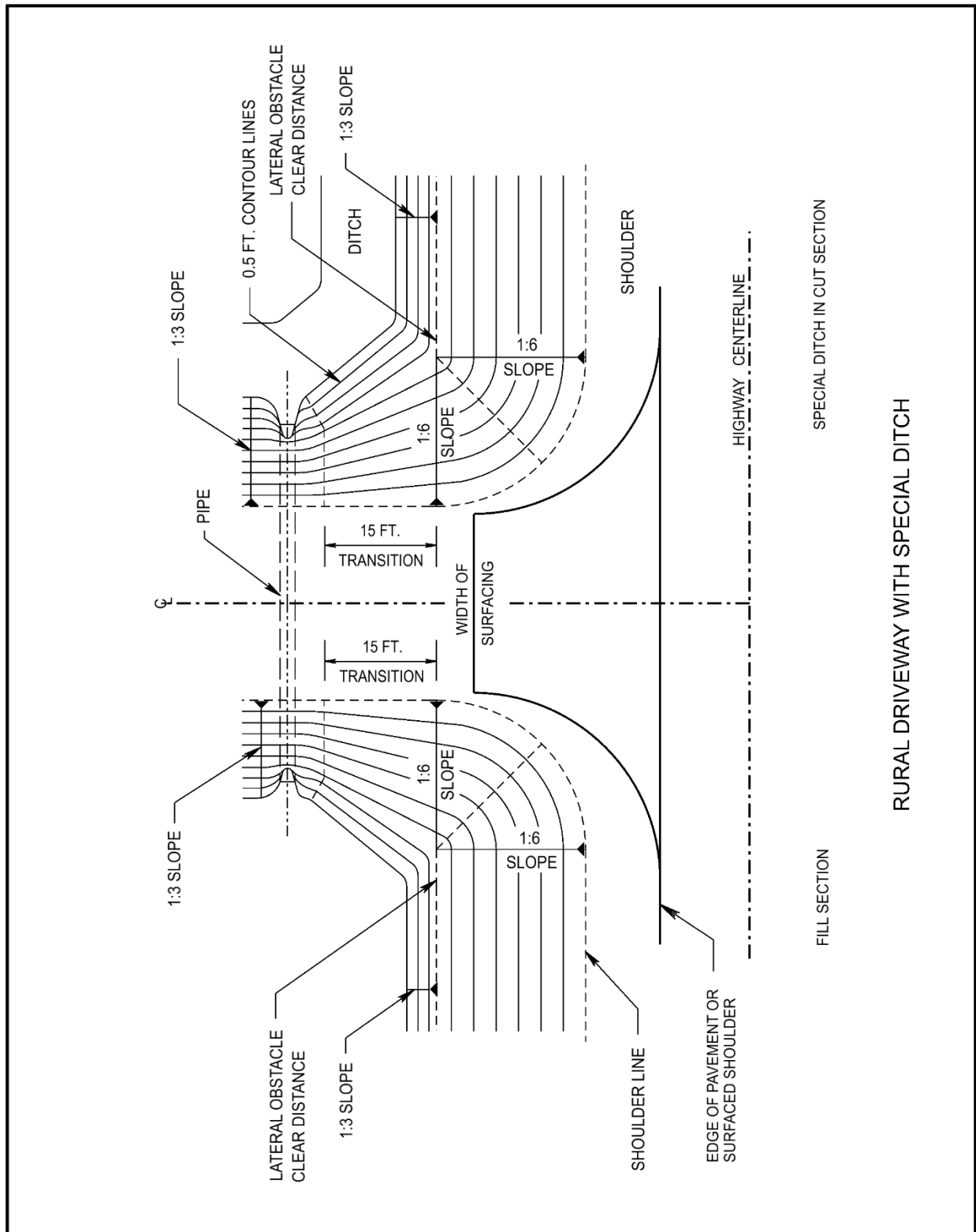


Exhibit 4.19 Rural Driveway With a Special Ditch



### 2.A.1 Rural Driveway Culvert Pipes

Driveway culvert pipes will be provided, where required, as a grading item. The following items should be considered in the design of rural driveway culvert pipes:

1. Driveway culvert pipe locations should be noted on the plan-in-hand field inspection.
2. The preferred location for a driveway culvert pipe is at the back of the ditch bottom, outside of the lateral clear zone (See [EXHIBITS 4.18 & 4.19](#)).
3. A minimum of one foot of cover should be provided over the culvert at the driveway shoulder break point (See [EXHIBIT 4.20](#)).
4. The minimum driveway culvert pipe diameter is 18 inches (24-inch diameter pipes are normally used). Larger culvert pipe diameters may be required based on the ditch hydraulics (See the [Drainage Design and Erosion Control Manual \(Drainage Manual\)](#), Chapter One: [Drainage](#), Sections 6, 7 & 8 (Ref. 4.15) (<https://dot.nebraska.gov/media/qhubv1ji/d-chap-one-drainage.pdf>).
5. Driveway culvert pipes will meet the requirements of the pipe material policy (See Appendix C, "Pipe Material Policy", of the *Drainage Manual*, Ref. 4.15) (<https://dot.nebraska.gov/media/2uaf4nxx/g3-appendix-c.pdf>) and Section 721 of the [Standard Specifications for Highway Construction \(Spec Book\)](#) (Ref. 4.16) (<https://dot.nebraska.gov/media/g4qp4y0d/2017-specbook.pdf>).

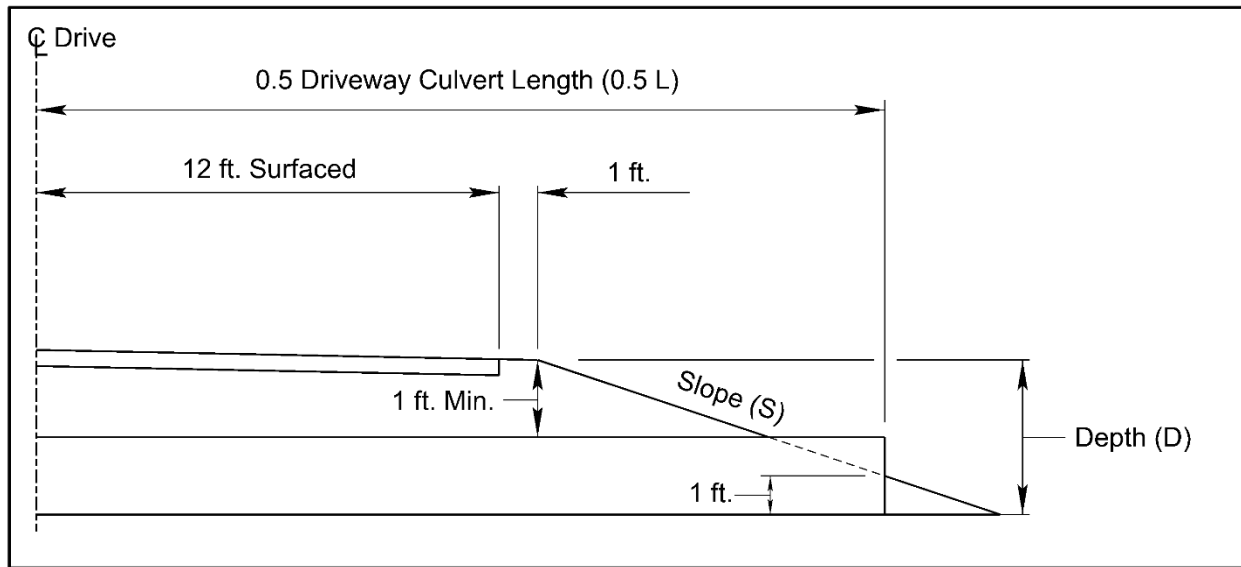
### 2.A.2 Hydraulic Design of Driveway Culverts

Driveway culverts are typically not analyzed for hydraulic capacity, based on the assumption that the highway ditch immediately adjacent to the driveway location only carries localized runoff from the pavement and highway right-of-way. The designer must be aware of the expected flows within the ditch at the drive location. If the driveway culvert carries flows from the lower end of a long vertical curve, the low side of a superelevated curve, and/or the ditch carries any additional drainage from the outside of the right-of-way, hydraulic capacity should be evaluated.

A Design Storm Frequency for hydraulic design of driveway culverts is not specifically designated in the *Drainage Manual* (Ref. 4.15). However, each type of highway facility (Interstate, Expressway, and Rural Highways classified by ADT) has an associated design storm designation by policy (See [EXHIBIT 1.3](#) of the *Drainage Manual*, Ref. 4.15). According to 23 CFR 650.105: "Design Flood shall mean the peak discharge, volume if appropriate, stage or wave crest elevation of the flood associated with the probability of exceedance selected for the design of a highway encroachment. By definition, the highway will not be inundated from the stage of the design flood."

Designers should be aware of the sentence underlined above; all aspects of design should be in conformance with it. In other words, the primary consideration for all culvert design, including driveway culverts, should be to keep the highway from being inundated by the Design Storm event. It is the designer's responsibility to verify that culvert headwater and/or overtopping does not inundate or encroach onto the highway pavement.

In most cases, it is not necessary to design the driveway culvert for the same return period as the highway culverts. It may be permissible to allow driveway overtopping to occur at low volume, low risk driveway locations if there is no encroachment of Stormwater onto the highway. It is necessary to consider and evaluate the potential impacts to the highway when the capacity of a driveway culvert is exceeded, including increased maintenance activities and damage to adjacent properties. The highway may be impacted when the capacity of culverts under driveways or county road intersections has been exceeded, especially when the highway is at a lower elevation than the driveway or county road.



26-FOOT-WIDE DRIVEWAY *				
DEPTH (D)	SIDE SLOPE (S)			
	1:3 <sup>1</sup>	1:4 <sup>2</sup>	1:6 <sup>3</sup>	1:10 <sup>4</sup>
3 feet (Min. D for a 24-inch Culv.)	38 feet	42 feet	50 feet	66 feet
3.5 feet (Min. D for a 30-inch Culv.)	41 feet	46 feet	56 feet	76 feet
4 feet (Min. D for a 36-inch Culv.)	44 feet	50 feet	62 feet	86 feet
4.5 feet (Min. D for a 42-inch Culv.)	47 feet	54 feet	68 feet	96 feet
5 feet (Min. D for a 48-inch Culv.)	50 feet	58 feet	74 feet	106 feet
5.5 feet (Min. D for a 54-inch Culv.)	53 feet	62 feet	80 feet	116 feet
6 feet	56 feet	66 feet	86 feet	126 feet
6.5 feet	59 feet	70 feet	92 feet	136 feet
7 feet	62 feet	74 feet	98 feet	146 feet
7.5 feet	65 feet	78 feet	104 feet	156 feet
8 feet	68 feet	82 feet	110 feet	166 feet
	<b>MINIMUM DRIVEWAY CULVERT PIPE LENGTH (L)</b>			

\* To determine the driveway culvert length for the maximum driveway width of 42 feet, add 16 feet to L.

For ditch depths other than those given:

1. Add 6 feet to L for each additional 1 foot of depth.
2. Add 8 feet to L for each additional 1 foot of depth.
3. Add 12 feet to L for each additional 1 foot of depth.
4. Add 20 feet to L for each additional 1 foot of depth.

**Exhibit 4.20 Minimum Rural Driveway Culvert Pipe Lengths**

**2.B Urban Driveways**

The number of urban driveways should be minimized to reduce the potential for accidents and to maintain highway capacity. Joint use driveways are desirable in urban locations to limit conflict points. Access control will be acquired for any urban tract where an existing driveway is closed (See Chapter Fifteen: Right-of-Way, Section 3, of this manual). Driveway access should be located outside of the storage length at signalized intersections to avoid conflicting movements and false signal actuations. Driveway design with signal controls requires a traffic analysis by **Traffic Engineering** to coordinate signal design and the roadway/intersection geometry.

Most driveway design in urban areas involves improvements to existing locations. Factors to be considered include:

- Traffic composition
- Right-of-way
- Accommodation of existing access
- Development of property being served
- Development of adjacent properties
- Access control regulations and requirements
- Location of curb inlets

All new urban driveway design will be in accordance with the criteria shown in EXHIBIT 4.21; see EXHIBIT 4.22 for a typical urban driveway design. Curb cut locations are governed by the Access Control Policy to the State Highway System (Ref. 4.12) and local ordinances. The geometry of the driveway will be referenced to the project centerline. Major driveways that are signalized should be designed as intersections. Driveway design involving shopping centers, truck stops, schools, plants with large parking lots, etc. require a special traffic analysis by **Traffic Engineering** to coordinate the number of lanes, traffic controls, and required storage lengths.

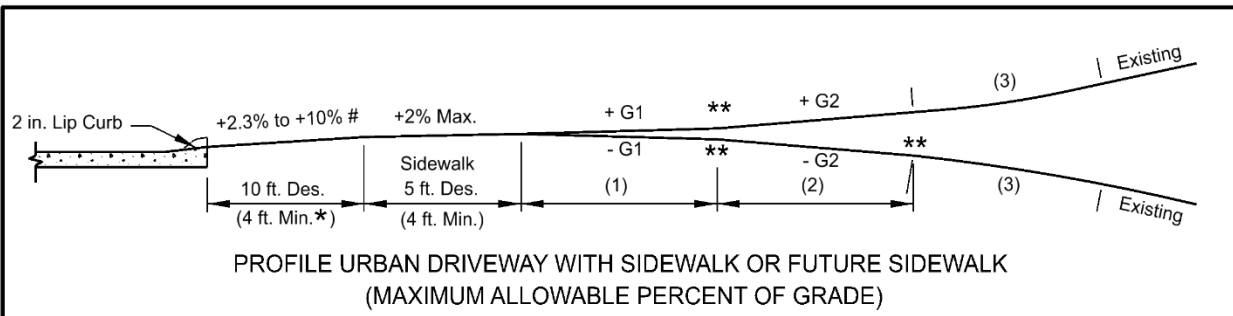
The allowable driveway grade between the two-inch slope curb and the sidewalk, not including sidewalks located directly behind the curb, will be between +2.3% and +10%, with a maximum allowable grade of +15% with **ADE** approval.

Driveway Type	Urban Driveway Width *	
	Residential Drive	Commercial Drive
Single	12 feet minimum	40 feet maximum
Double	24 feet maximum, in existing locations only. Use single in new locations.	---
Joint Use (Driveway on property line)	24 feet desirable	40 feet maximum

Notes: The minimum urban driveway radius is 10 feet with 15 feet desirable and 25 feet maximum for commercial driveways.

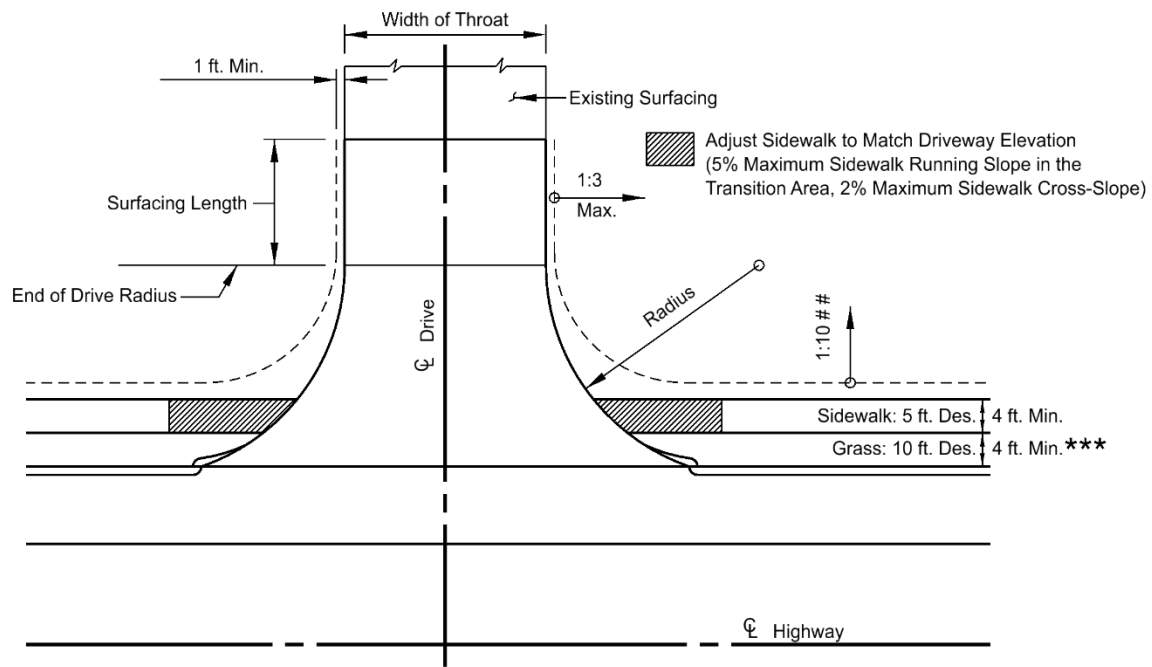
\* Measured at the throat of the driveway.

**Exhibit 4.21 Urban Driveway Width Criteria**



- (1) 10 ft. min. is required when the existing grade is greater than 8%.
- (2) 10 ft. min. is required when the existing grade is greater than 15%.
- (3) 10 ft. min. rounding is required when the existing grade is greater than 22%.
- \* 0 ft. is allowed in urban business districts with sidewalks of 6 ft. min. width.
- \*\* 10 ft. min. rounding desirable for the following grade changes:
  - For sags with a change in grade greater than 7% use an 80 ft. min. radius.
  - For crests with a change in grade greater than 10% use a 50 ft. min. radius.
- # A rise of 2 in. or less between the back of curb and the sidewalk will require an edge drain.

DRIVEWAY TYPE	G1 (MAX.)	G2 (MAX.)
COMMERCIAL, INDUSTRIAL	+/- 5%	+/- 8%
DWELLINGS (RESIDENTIAL)	+/- 8%	+/- 15%



# 1:10 desirable, 1:6 minimum within lateral obstacle clearance distance, then transition to 1:3 in 15 ft.  
 \*\*\* 0 ft. allowed in urban business districts with sidewalks of 6 ft. minimum width.

**URBAN DRIVEWAYS**

**Exhibit 4.22 Urban Driveway**

### 3. SURFACING

The determination of surfacing type for intersections and driveways is site specific; there are no absolute rules governing this topic. Surfacing type for intersections and drives should be addressed in the pavement determination and discussed at the plan-in-hand meetings, utilizing the **District's** local experience.

#### 3.A Intersection Surfacing Guidelines

See [EXHIBIT 4.23](#). Where parallel railroad tracks run within 200 feet of the edge of the pavement, the crossroad should be surfaced to the railroad right-of-way and may be surfaced to the tracks with **District Engineer (DE)** approval. Any work on railroad right-of-way requires the approval of the **DE** and a special provision prepared by the **Rail Unit** in the **Local Assistance Division**.

#### 3.B Driveway Surfacing Guidelines

In most cases the limit of surfacing will be either to the end of the driveway radius or to the existing driveway surface, the choice will depend on which is the least distance from the edge of the pavement, allows for a suitable driveway grade, and matches into the remaining portion of the driveway. Check with the **DE** at the plan-in-hand for verification. See [EXHIBITS 4.22 & 4.24](#) for examples.

Field entrances will not be surfaced except in the Sandhills Region; millings should be used to surface field entrances whenever possible (verify with the **DE** at the plan-in-hand field inspection).

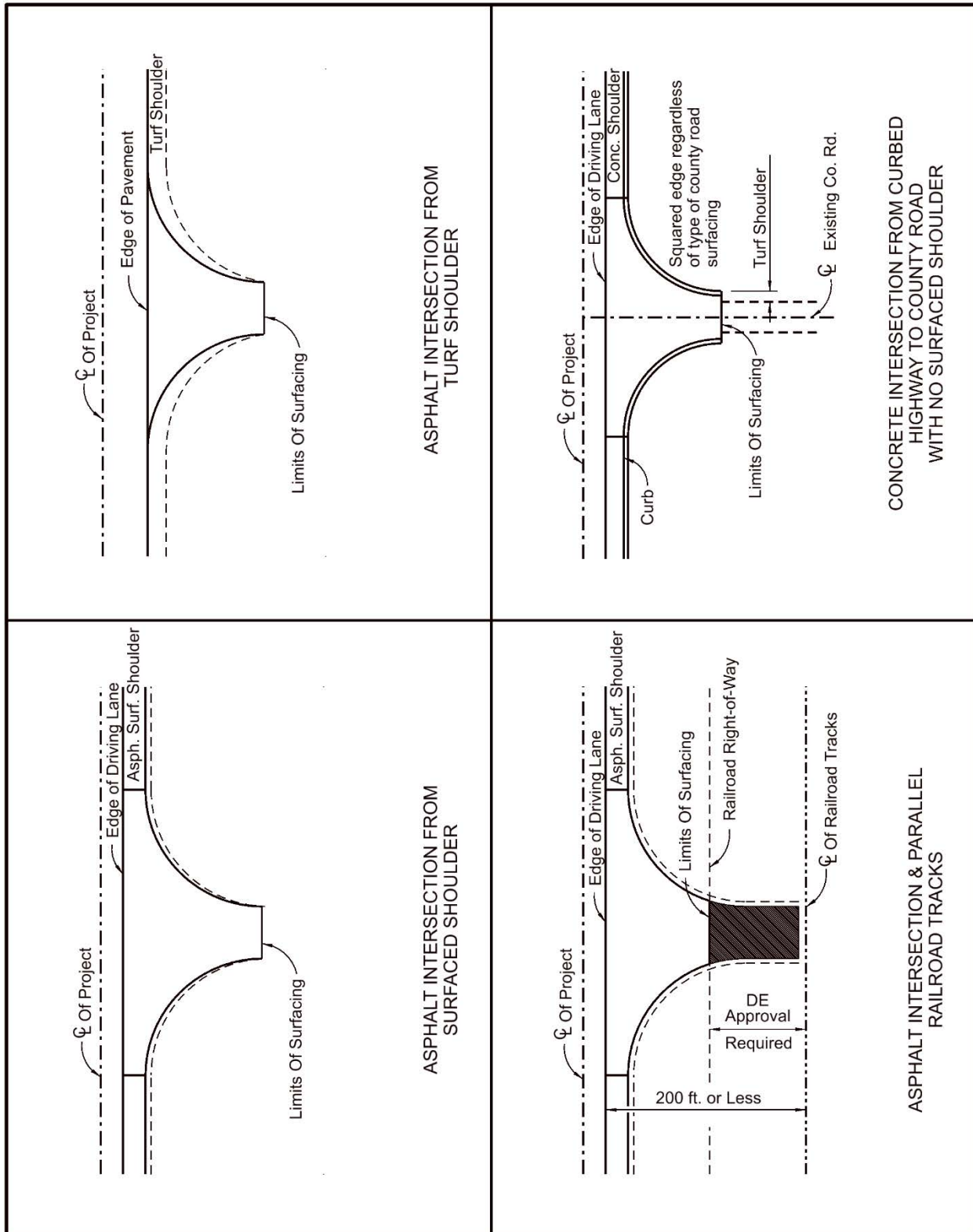


Exhibit 4.23 Limits of Surfacing at Co. Road Intersections and Other Public Roads

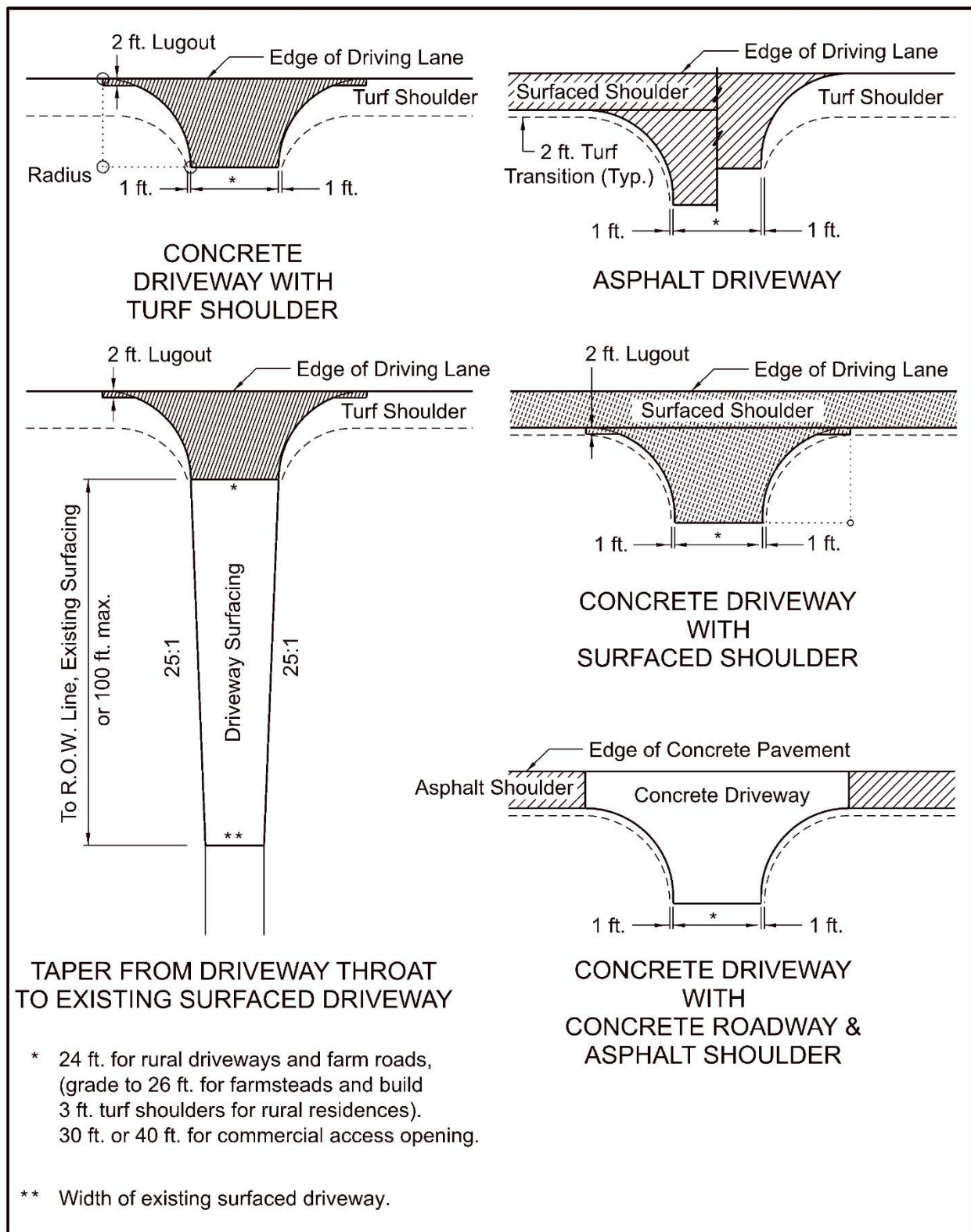


Exhibit 4.24 Surfacing Criteria for Rural Driveways

#### 4. BUILD NOTES FOR INTERSECTIONS AND DRIVEWAYS

The following guidelines have been established for build notes for intersections and driveways:

1. Use "BUILD" in the note for driveways and intersections if any of the following conditions are present:
  - A new driveway or intersection is being constructed or an existing driveway or intersection is being relocated
  - The top width of the intersection or driveway is being changed
  - A new driveway pipe is being laid or an existing pipe is being re-laid
  - A new culvert pipe is being constructed within the radii of an existing surfaced intersection
2. Use "SURFACE" in the note for driveways and intersections if none of the above conditions are present. On resurfacing projects without surfaced shoulders, new roadway grading which is contoured around an existing intersection will not be considered as a change in the top width.
3. If a "BUILD" note is used for an intersection note, the words "and surface" will not be in the note.
4. If a "BUILD" note is used for a driveway note and the driveway is also to be surfaced, the words "and surface" will be included in the note.



## 5. CHANNELIZATION

Islands and medians may be used to divide and direct traffic. The degree of channelization required for a roadway is influenced by the patterns and volume of both vehicular and pedestrian traffic during peak periods. A traffic analysis, identifying the relative importance of conflicting movements, is performed by **Traffic Engineering** to establish the type of channelization to be used. Examples of channelized intersection designs are shown in EXHIBITS 4.25 & 4.26. The designer should coordinate with **Traffic Engineering** throughout intersection design regarding channelization and other issues.

The following guidelines should be considered when designing a channelized intersection:

1. Motorists should be confronted with no more than one decision at a time.
2. Turns greater than 90° and sudden sharp reverse curves should be avoided.
3. Areas of vehicle conflict should be reduced as much as possible.
4. Points of crossing or conflict should be evaluated for other possible treatments such as separation or consolidation with appropriate control devices.
5. Storage areas for turning vehicles should be provided clear of the through traffic lane.
6. Approach road designs based on refuge for vehicles in medians, to either turn left or to pass straight through, will not be considered.
7. Prohibited turns should be blocked wherever possible.
8. The location of traffic control devices should be established as a part of the channelization design.
9. Channelization may be desirable to separate various traffic movements where multiple phase signals are used.
10. All turning movements should be checked with the appropriate design vehicle (See EXHIBIT 4.13).
11. Lighting warrants should be checked when raised channelization is introduced at an intersection.

For additional information, see Section 9.6.2, "Channelization"; Section 9.6.3, "Islands"; and Section 9.8, "Median Openings" in Chapter 9 of the *Green Book* (Ref. 4.1).

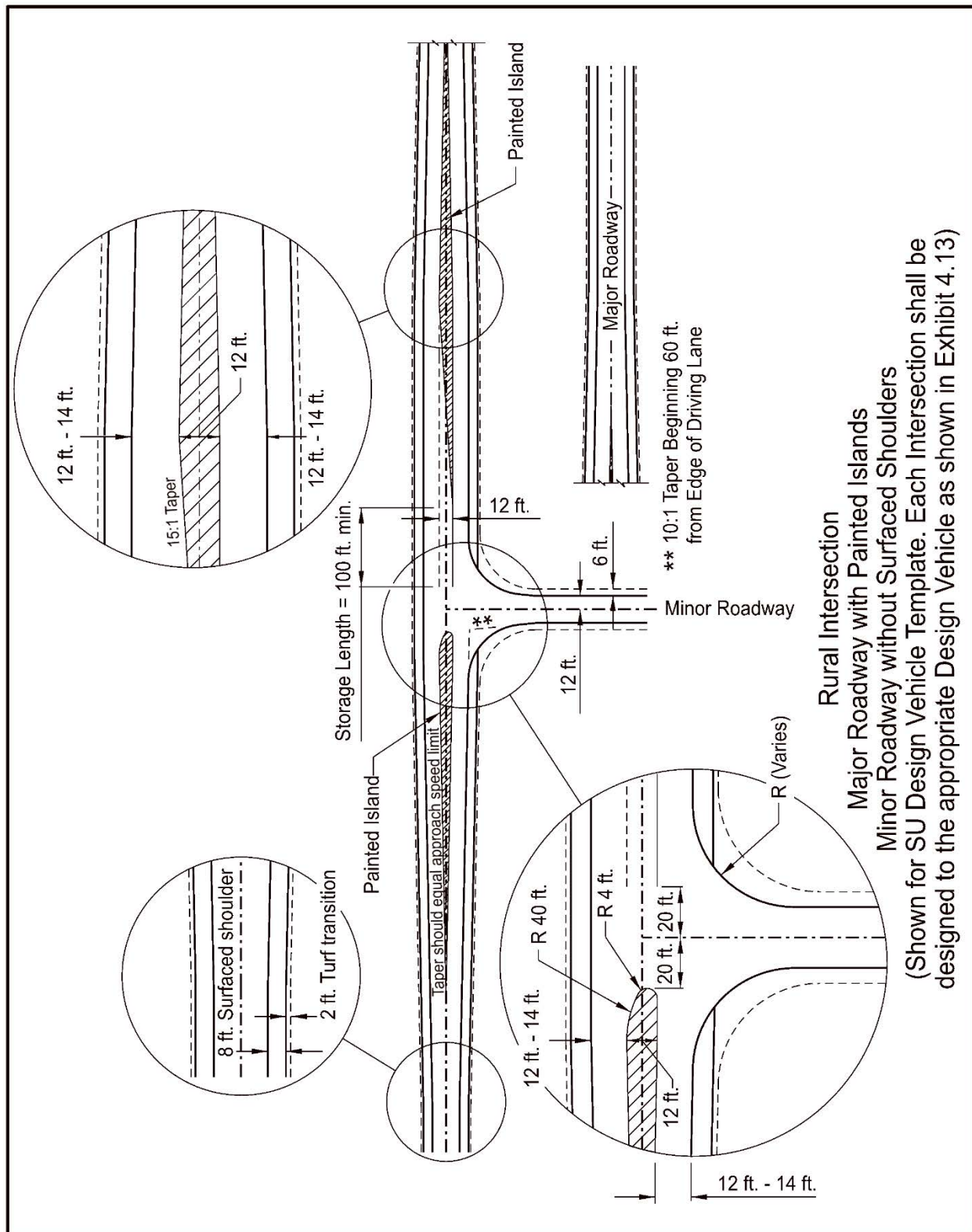
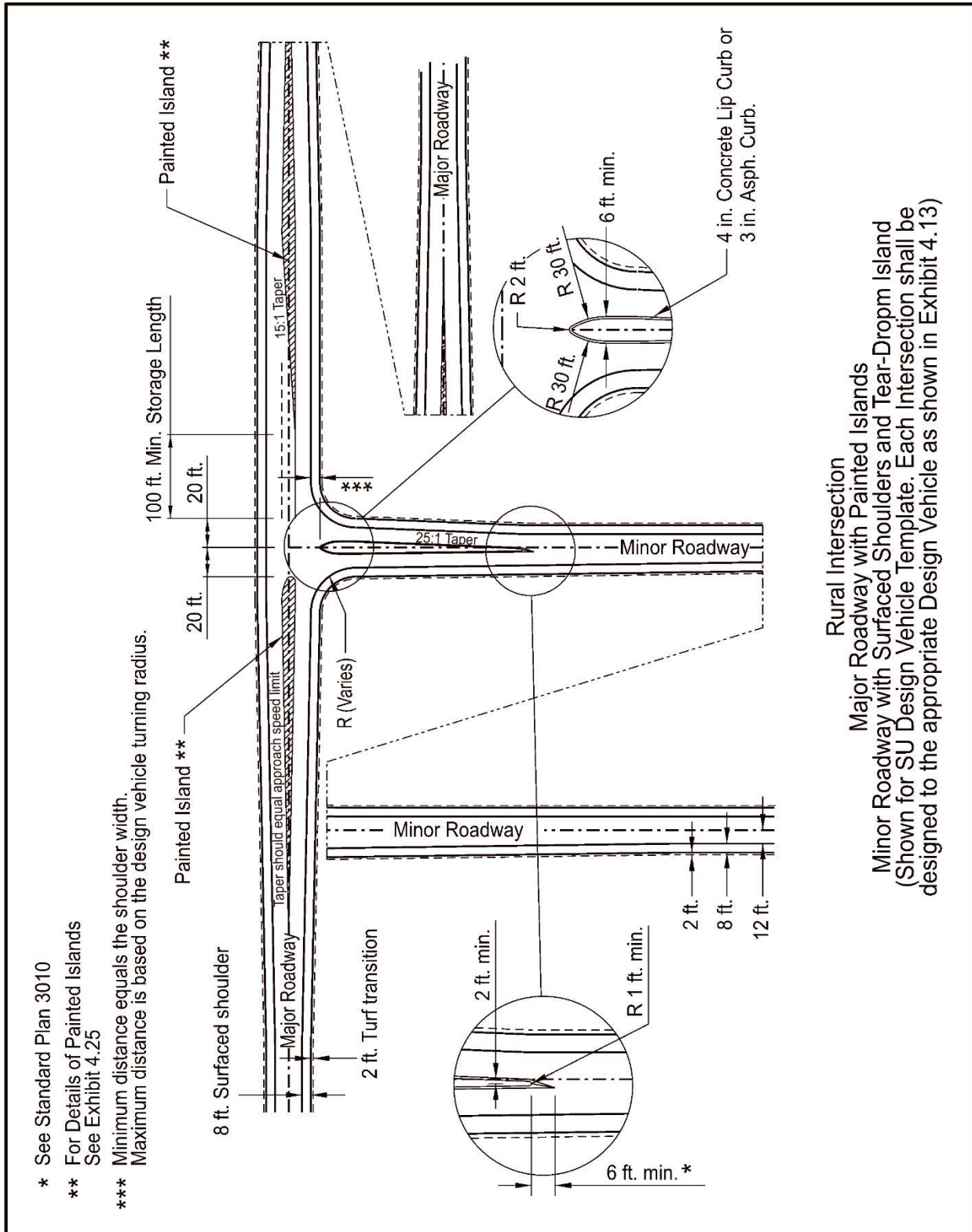


Exhibit 4.25 Example of Rural Three-Leg Intersection with Minor Roadway Without Surfaced Shoulder



- \* See Standard Plan 3010
- \*\* For Details of Painted Islands See Exhibit 4.25
- \*\*\* Minimum distance equals the shoulder width. Maximum distance is based on the design vehicle turning radius.

Rural Intersection  
 Major Roadway with Painted Islands  
 Minor Roadway with Surfaced Shoulders and Tear-Drop Island  
 (Shown for SU Design Vehicle Template. Each Intersection shall be designed to the appropriate Design Vehicle as shown in Exhibit 4.13)

Exhibit 4.26 Example of a Rural Three-Leg Intersection with Minor Roadway With Surfaced Shoulder

## 5.A Islands

Islands should be designed to define the driving path. Islands may be flush or raised and may be delineated by surfacing materials or pavement markings.

For non-developed suburban crossroads, the following guidelines apply:

1. If the intersection warrants signalization within five years of the programmed construction the project may include signals, based on a recommendation from **Traffic Engineering**. A raised or flush median (determined on a project-by-project basis) and a left turn lane may be constructed. If access control is purchased along the mainline roadway it should extend up the crossroad (See Chapter Fifteen: Right-of-Way, EXHIBITS 15.5, 15.6, & 15.7, of this manual).
2. If signals are not warranted within five years from construction but may be warranted at sometime within 20 years of construction, the grading may be accomplished for future islands and turn lanes, but the paving will be constructed to two-lane, stop-control geometrics.

For urban and developed suburban crossroads, the following guidelines apply:

1. If signals are warranted within five years of construction, the project may include signals. An island and a left turn lane may be built.
2. If signals are not warranted within five years of construction, a standard two-lane intersection will be constructed. When signals are installed, the intersection will be reconstructed as required.

### 5.A.1 **Raised Islands**

Raised islands provide the most positive delineation and may be used to control undesirable turning movements.

The use of a raised island for pedestrian refuge should be considered if a crosswalk passes through the channelization. Raised islands may also be used for the placement of traffic signals. For concrete island and curb ramp details see the Standard/Special Plan Book (Standard Plans) (Ref. 4.14) (<https://dot.nebraska.gov/business-center/design-consultant/stand-spec-manual/>). See Chapter Sixteen: Pedestrian and Bicycle Facilities, Section 7, of this manual for information regarding pedestrian crosswalks.

The allowable curb height on raised islands is a function of the design speed. The following **NDOT** curb policy applies:

- On high-speed facilities (design speed  $\geq$  50 mph), three-inch and four-inch concrete slope curb and three-inch asphaltic concrete curb are permitted in both urban and rural settings (See EXHIBIT 6.16).
- On low-speed facilities (design speed  $\leq$  45 mph), six-inch integral concrete curbs are permitted (See EXHIBIT 6.16).

Lighting warrants should be checked when raised islands are used.

Teardrop raised islands on the minor roadway approach are acceptable at state highway intersections with high-volume roads (See [EXHIBITS 4.7 & 4.26](#)). These islands should be installed for placement of the stop sign when the intersection return must be widened to accommodate turning trucks. The designer should design the island and the intersection geometry so that it does not conflict with the design vehicle's turning movements.

## **5.B      Medians**

A median is defined as the portion of a divided highway which separates the opposing traffic lanes.

### **5.B.1      Median Uses**

Medians on multilane highways and roadways may provide the following benefits:

- Separate opposing traffic movements
- Provide a recovery area for errant vehicles
- Facilitate the drainage on crowned multilane sections
- Prevent undesirable turning movements
- Provide space for deceleration lanes and storage for left turning vehicles
- Provide width for future lanes

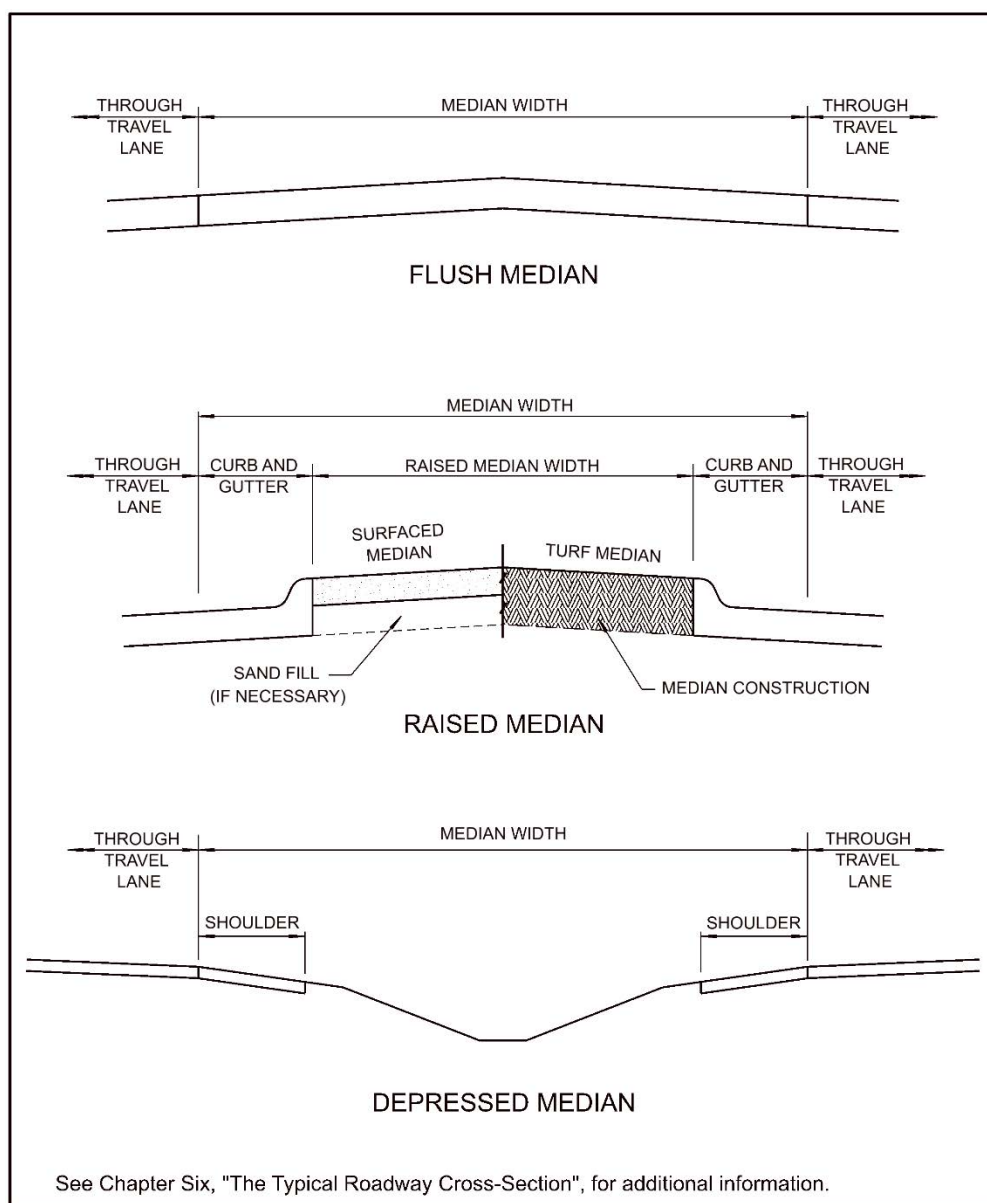
### **5.B.2      Median Types**

1. Flush Medians - Flush medians are typically used on urban highways and streets. These medians are often used as two-way left-turn lanes (TWLTL) in urban areas.
2. Raised Medians - Raised medians are typically used on urban and suburban highways and streets to control access and left turns (the *Standard Plans*, Ref. 4.14, shows a typical detail of a raised concrete median). The decision of whether to surface a raised median, and surfacing type, should be made on the plan-in-hand field inspection. Mow strips (a two-foot surfaced section between the curb and the turf) may also be considered.
3. Depressed Medians - Depressed medians are typically used on freeways, where practicable, and on other divided arterials. Depressed medians have better drainage characteristics than raised medians.

[EXHIBIT 4.27](#) illustrates the different median types.

### 5.B.3 Median Width

The width of the median is the distance between the inside edges of the through travel lanes (See [EXHIBIT 4.27](#)). The median width depends on the type of facility, costs, existing and future development, and right-of-way limitations. The desirable depressed median width for an Interstate is 64 feet, the desirable depressed median width for a four-lane freeway or expressway is 54 feet. Variations in median widths should be considered on a case-by-case basis at the plan-in-hand inspection. Roadway designers should check the width and placement of any piers in the median and, if necessary, adjust the roadway design accordingly. The width of the pier cap will also be checked to verify that the minimum allowable vertical clearance is being maintained (See Chapter Ten: [Miscellaneous Design Issues](#), Section 2.E, of this manual).



**Exhibit 4.27 Median Types**

#### 5.B.4 Median Breaks

Median breaks may be provided to allow access to driveways and crossroads. The turning template for the appropriate design vehicle (See [EXHIBIT 4.13](#)) and the intersection/driveway environment will be used to determine the median opening width and intersection/driveway geometry. The designer should also check the effects of median channelization on neighboring intersections and driveways. Median openings are typically graded so that this pavement area drains away from the driving lanes.

Four types of median breaks may be used on divided roadways.

##### 5.B.4.a Type A Median Breaks

Type A median breaks ([EXHIBITS 4.29, 4.30, 4.32, 4.35 & 4.40](#)) may be used at intersections of the mainline with roadways having a classification of "Other Arterial" or higher and at intersections with paved public roads where there is high probability of turning vehicles blocking the opposing turning driver's line of sight (the left turn lanes of a Type A median break are offset so that the driver's line of sight will not be obstructed). At other locations a special traffic study by **Traffic Engineering** will be required to justify the use of a Type A median break. Roadway designers will consult with their **ADE** when proposing the use of Type A median breaks. The length of a Type A median break consists of:

1. A lane change and deceleration distance to shift the turning traffic from the through lane and to slow the traffic to a full stop (See [EXHIBIT 4.28](#)). Note: the lengths given in [EXHIBIT 4.28](#) are based on a deceleration rate of 6.5 ft./s<sup>2</sup>. If this is not practicable, the Stopping Sight Distance (See the *Green Book* (Ref. 4.1), **Table 3-1**), based on a deceleration rate of 11.2 ft./s<sup>2</sup>, may be used.

And

2. A storage length provided by **Traffic Engineering**. The minimum storage length will be 50 feet (providing storage for two passenger cars at 25 feet per car) for urban and suburban streets with speeds ≤ 35 mph, or 100 feet for high-speed urban and suburban streets (≥ 40 mph) and on rural roadways. See the *Green Book* (Ref. 4.1), **Tables 9-21 and 9-22** for additional information.

##### 5.B.4.b Type B Median Breaks

Type B median breaks ([EXHIBITS 4.29, 4.31, 4.33, 4.36 & 4.41](#)) are appropriate for use at mainline intersections with gravel county roads, with housing development intersections, and with rural commercial driveways. The length of a Type B median break consists of:

1. A lane change and deceleration distance to shift the turning traffic from the through lane and to slow the traffic to a full stop (See [EXHIBIT 4.28](#)). Note: the lengths given in [EXHIBIT 4.28](#) are based on a deceleration rate of 6.5 ft./s<sup>2</sup>. If this is not practicable, the Stopping Sight Distance (See the *Green Book* (Ref. 4.1), **Table 3-1**), based on a deceleration rate of 11.2 ft./s<sup>2</sup>, may be used.

And

2. A storage length. The minimum storage length will be 50 feet (providing storage for two passenger cars at 25 feet per car) for urban and suburban streets with speeds  $\leq 35$  mph, or 100 feet for high-speed urban and suburban streets ( $\geq 40$  mph) and on rural roadways. See the *Green Book* (Ref. 4.1), **Tables 9-21** and **9-22** for additional information.

**Traffic Engineering** should be consulted for the appropriate storage length if the mainline traffic volume is over 9000 ADT, if the opposing peak hour traffic volume is over 500, if the peak hour turning traffic volume is 100 VPH or greater, and for rural commercial driveways.

#### 5.B.4.c Type C Median Breaks

Type C median breaks (EXHIBITS 4.29, 4.31, 4.34, 4.37, 4.38, 4.42 & 4.43) are appropriate for use at mainline intersections with farmstead/rural residence driveways. The length of a Type C median break includes a 15:1 taper to shift the turning traffic to the left of the through lane.

#### 5.B.4.d Type D Median Breaks

Type D median breaks (EXHIBITS 4.34, 4.39 & 4.44) are used at an intersection with a field entrance.

Speed (mph)	Lane Change and Deceleration Distance (ft.)
20	70
25	105
30	150
35	205
40	265
45	340
50	415
55	505
60	600
65	700
70	815

Deceleration lengths are based on a 6.5 ft/s<sup>2</sup> deceleration throughout the entire length. Larger deceleration rates may be used when deceleration lengths based on 6.5 ft/s<sup>2</sup> are impractical.

Access points should not be located in the deceleration areas.

#### Exhibit 4.28 Desirable Lane Change and Deceleration Distances

Source: **Table 9-20** of the *Green Book* (Ref. 4.1)



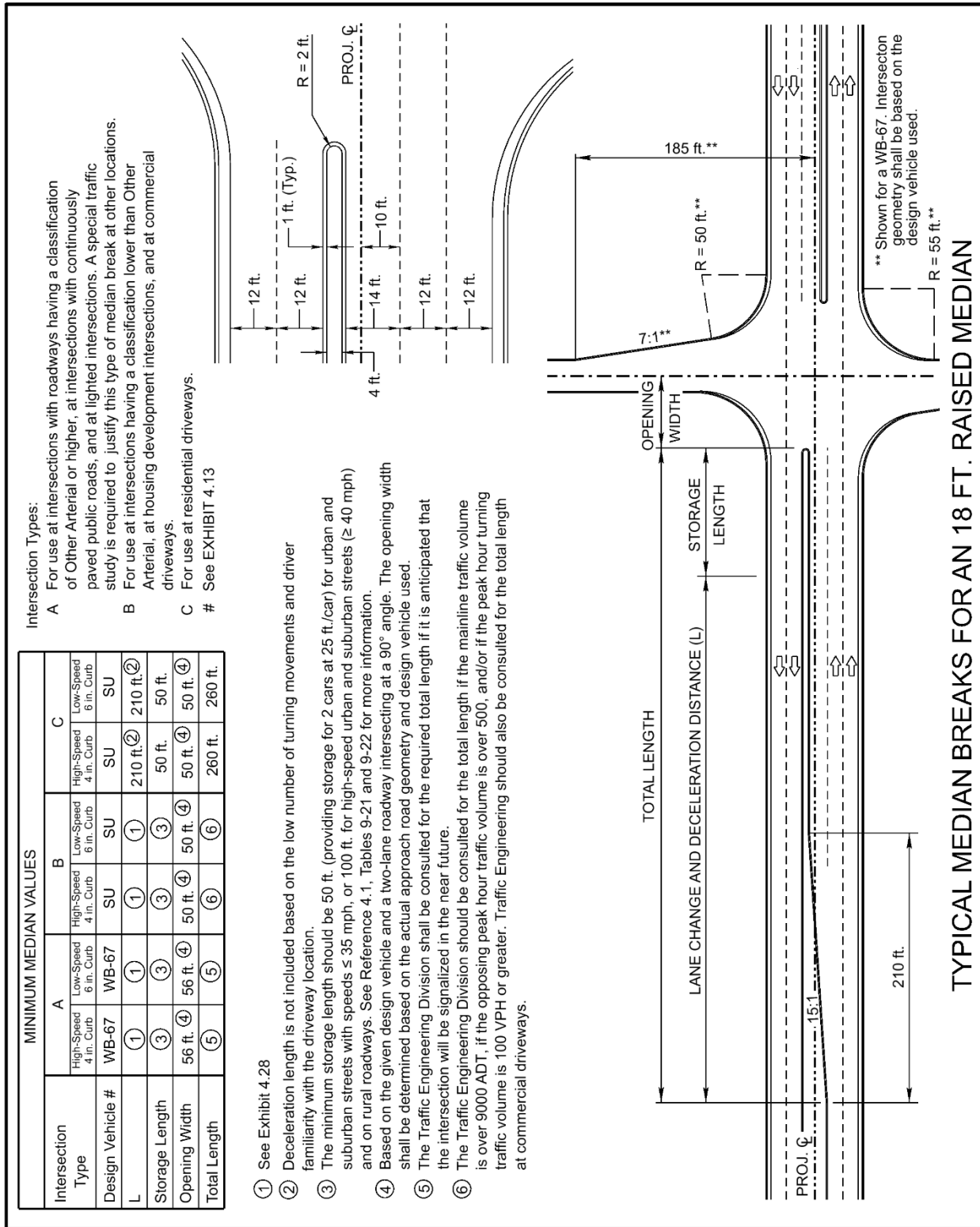


Exhibit 4.29 Typical Median Breaks (18 Foot Raised Medians)

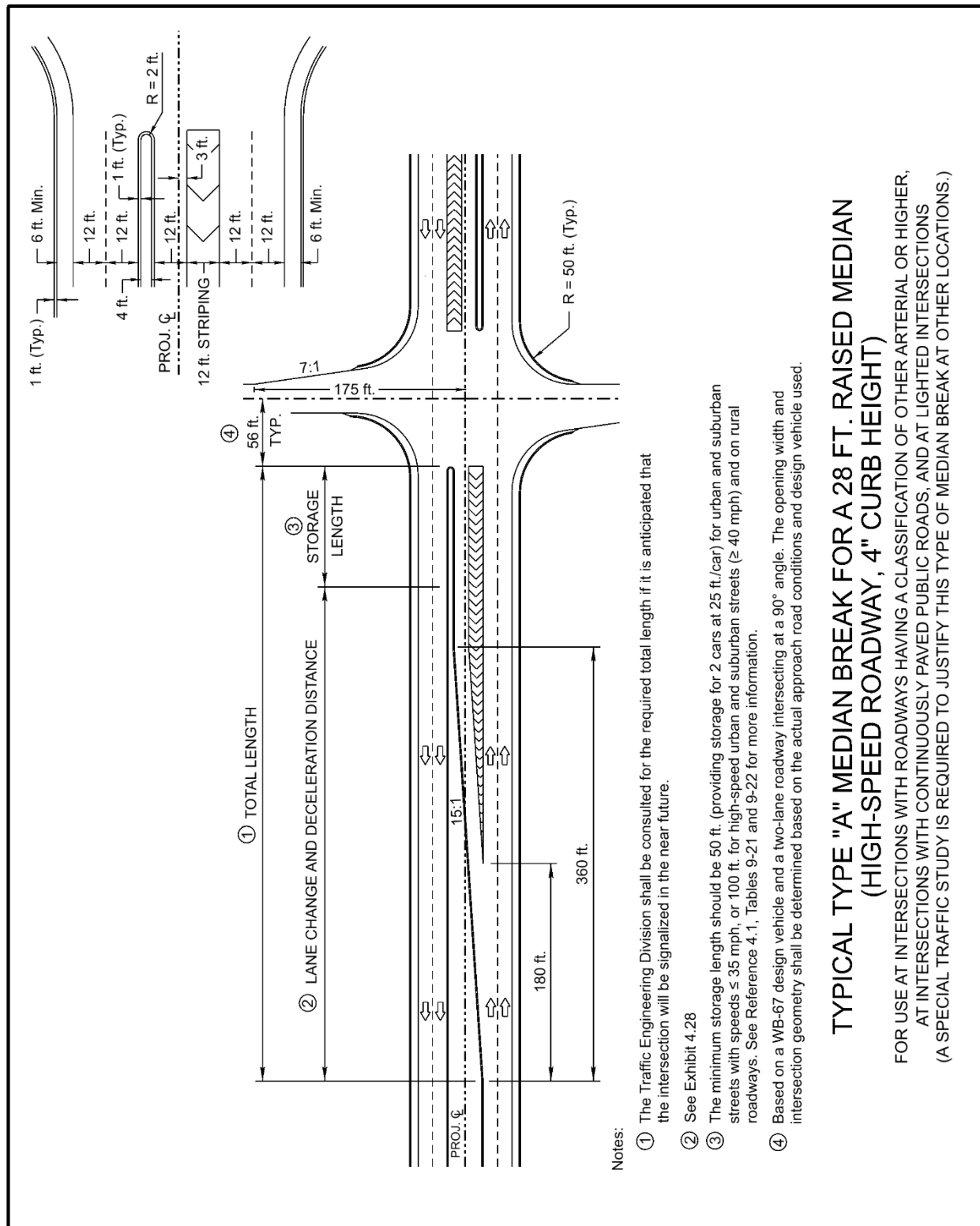
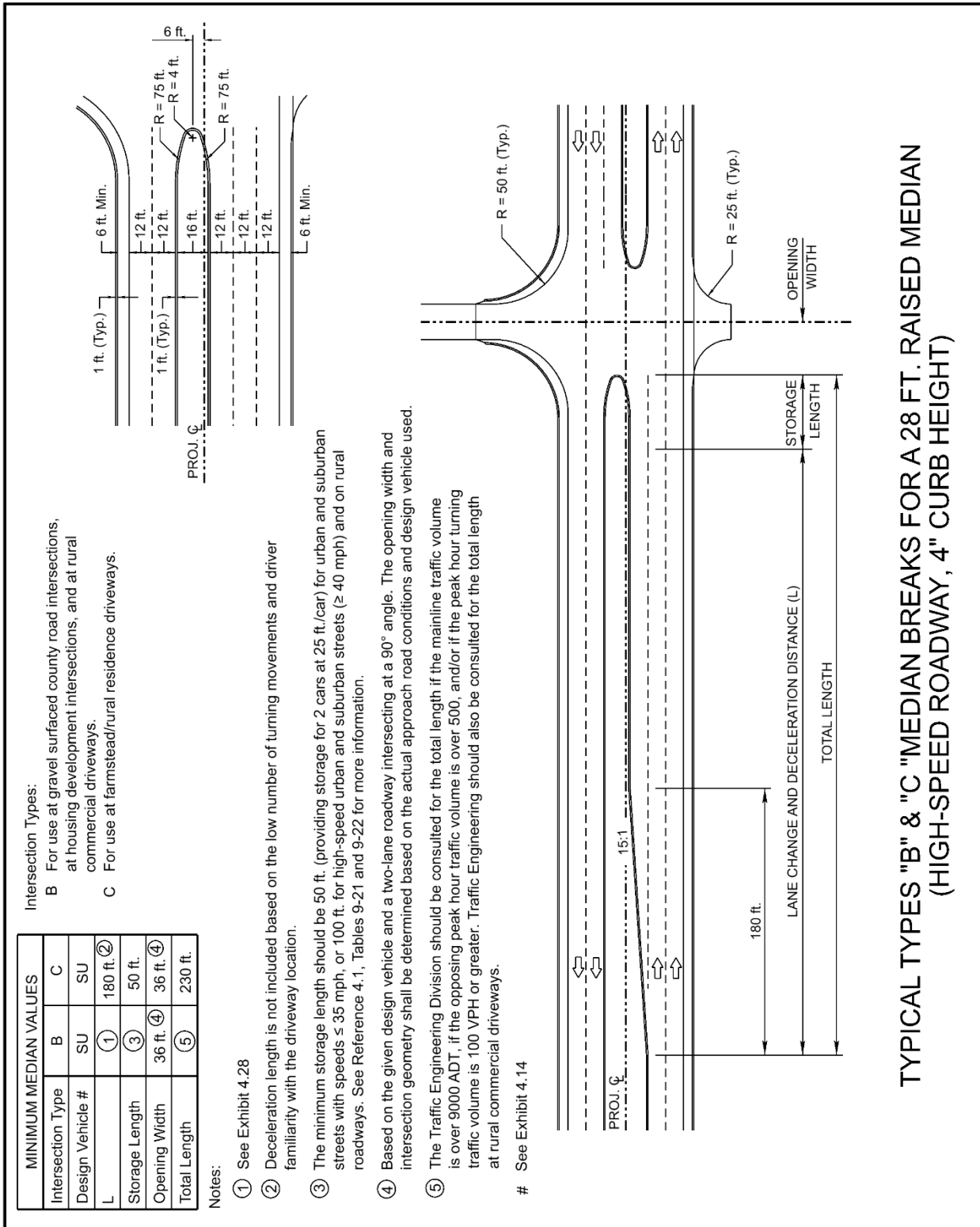


Exhibit 4.30 Typical Type A Median Break (28 Foot Raised Median)



**Exhibit 4.31 Typical Types B and C Median Breaks (28 Foot Raised Medians)**

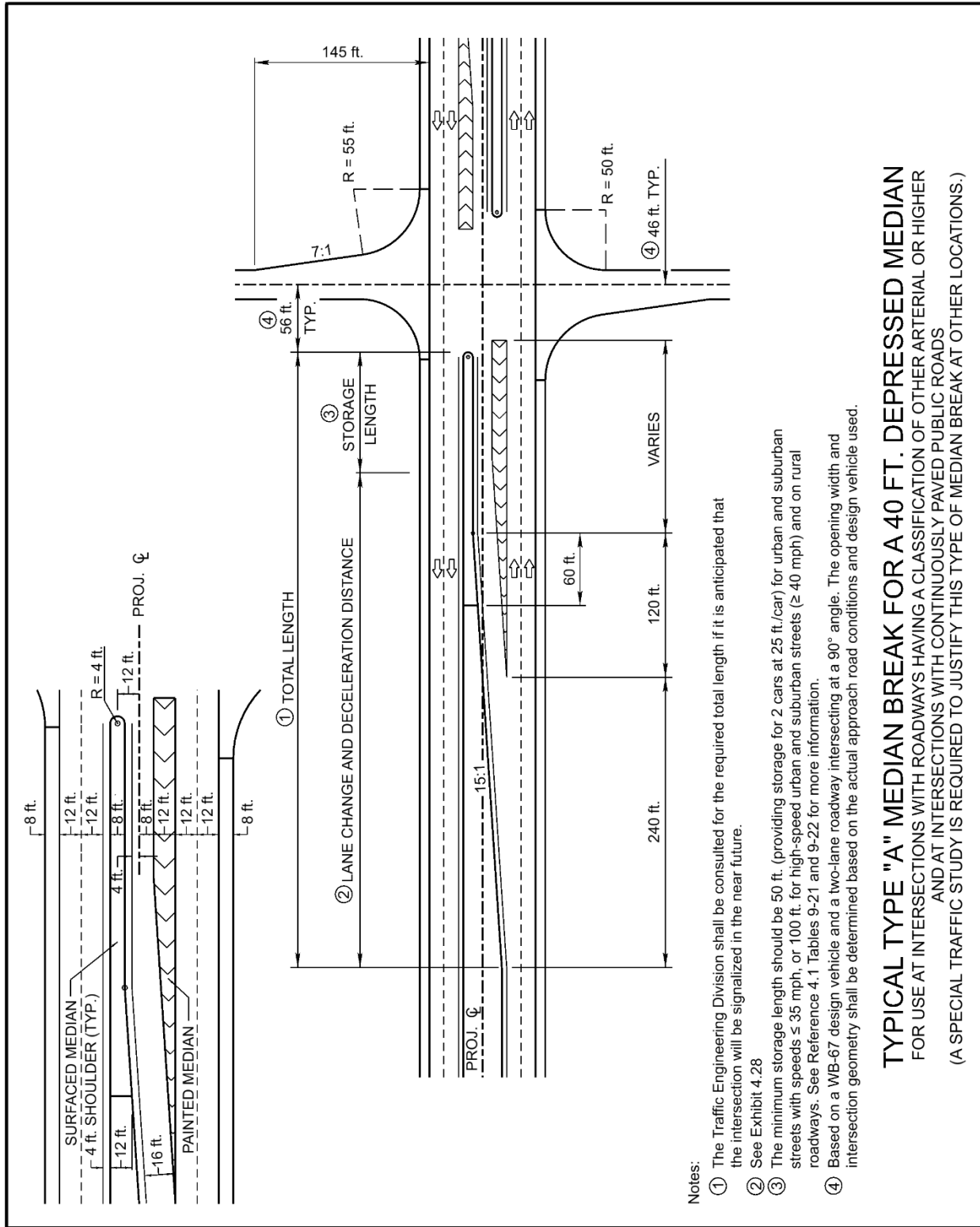


Exhibit 4.32 Typical Type A Median Break (40 Foot Depressed Median)

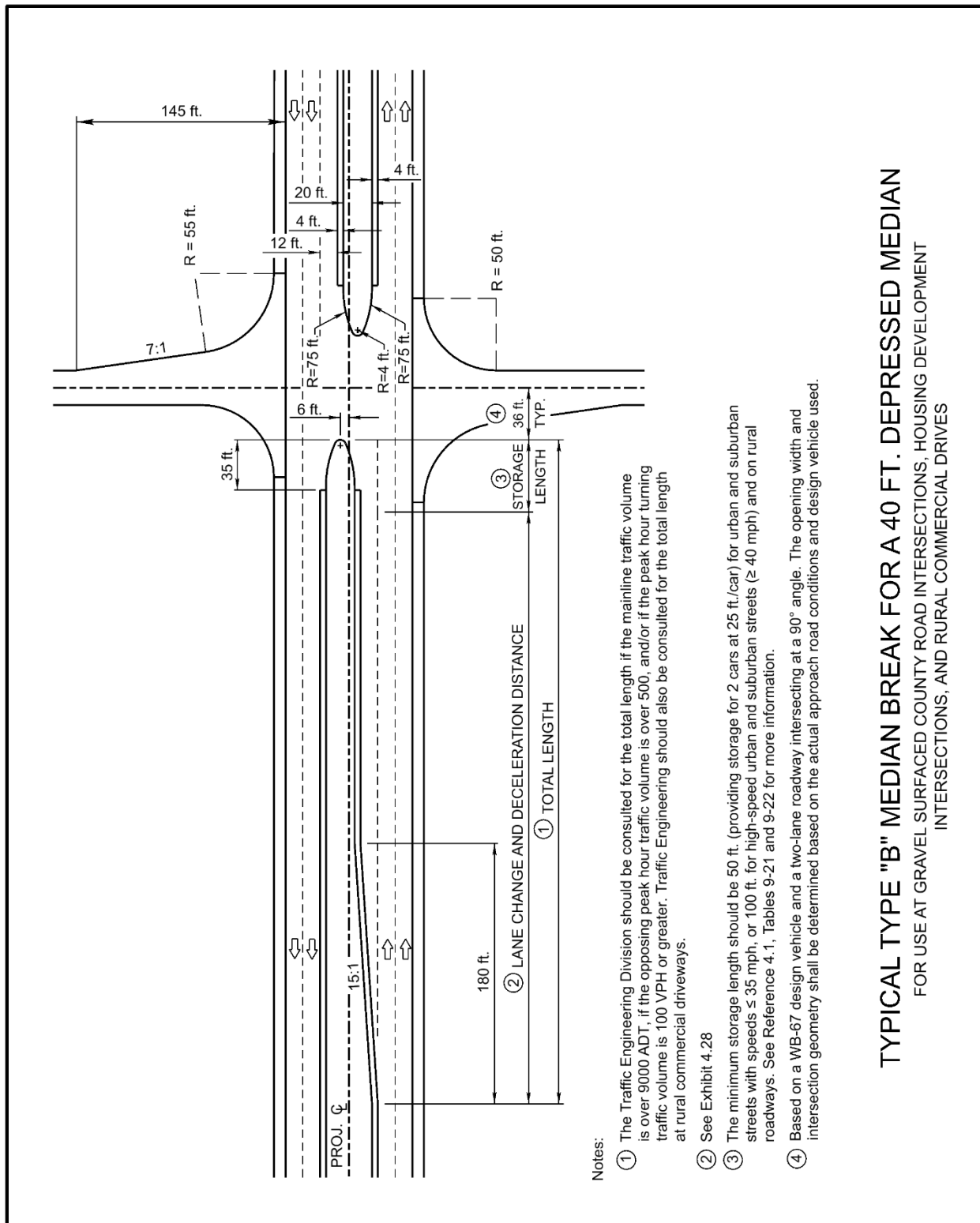


Exhibit 4.33 Typical Type B Median Break (40 Foot Depressed Median)

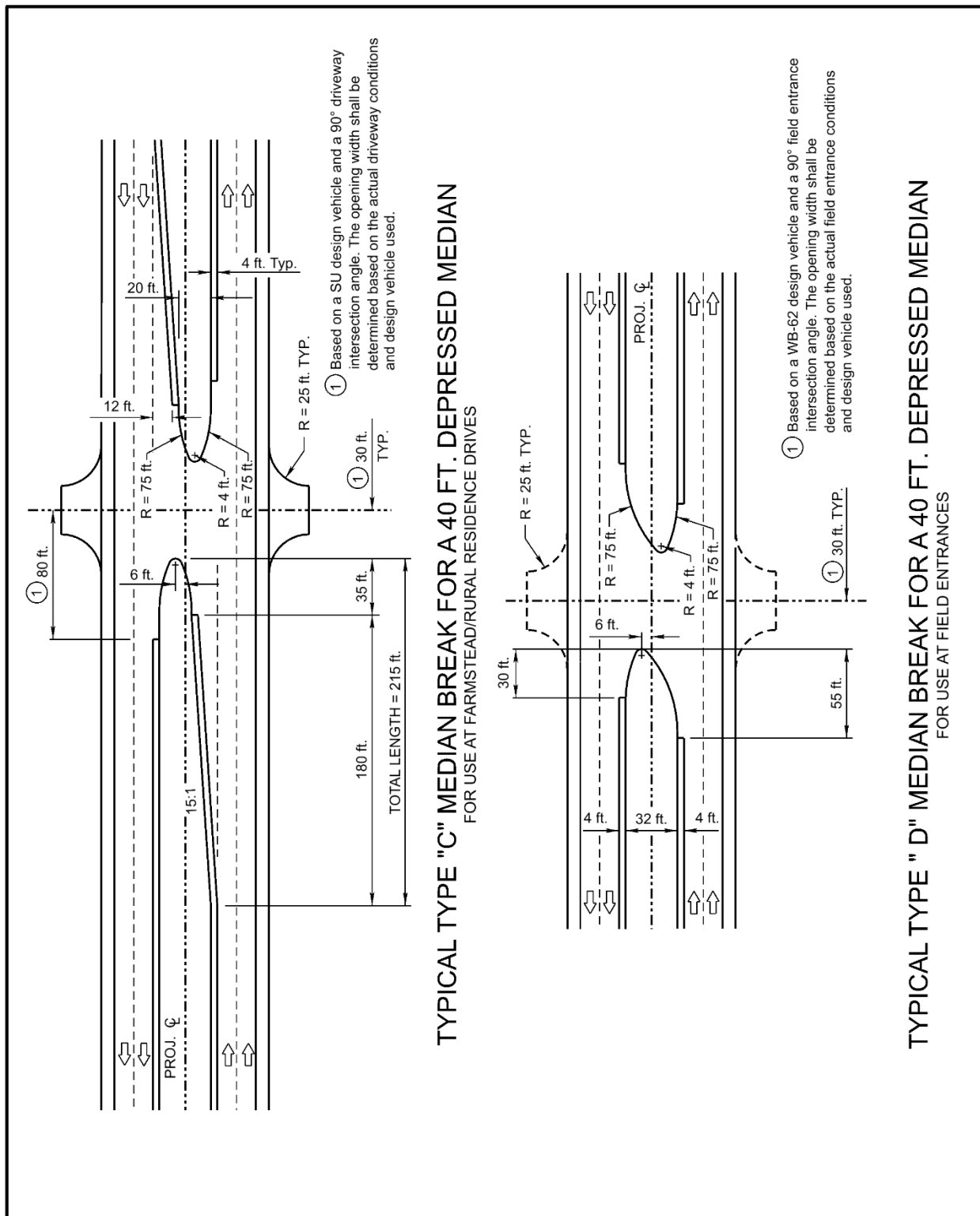


Exhibit 4.34 Typical Types C and D Median Breaks (40 Foot Depressed Median)

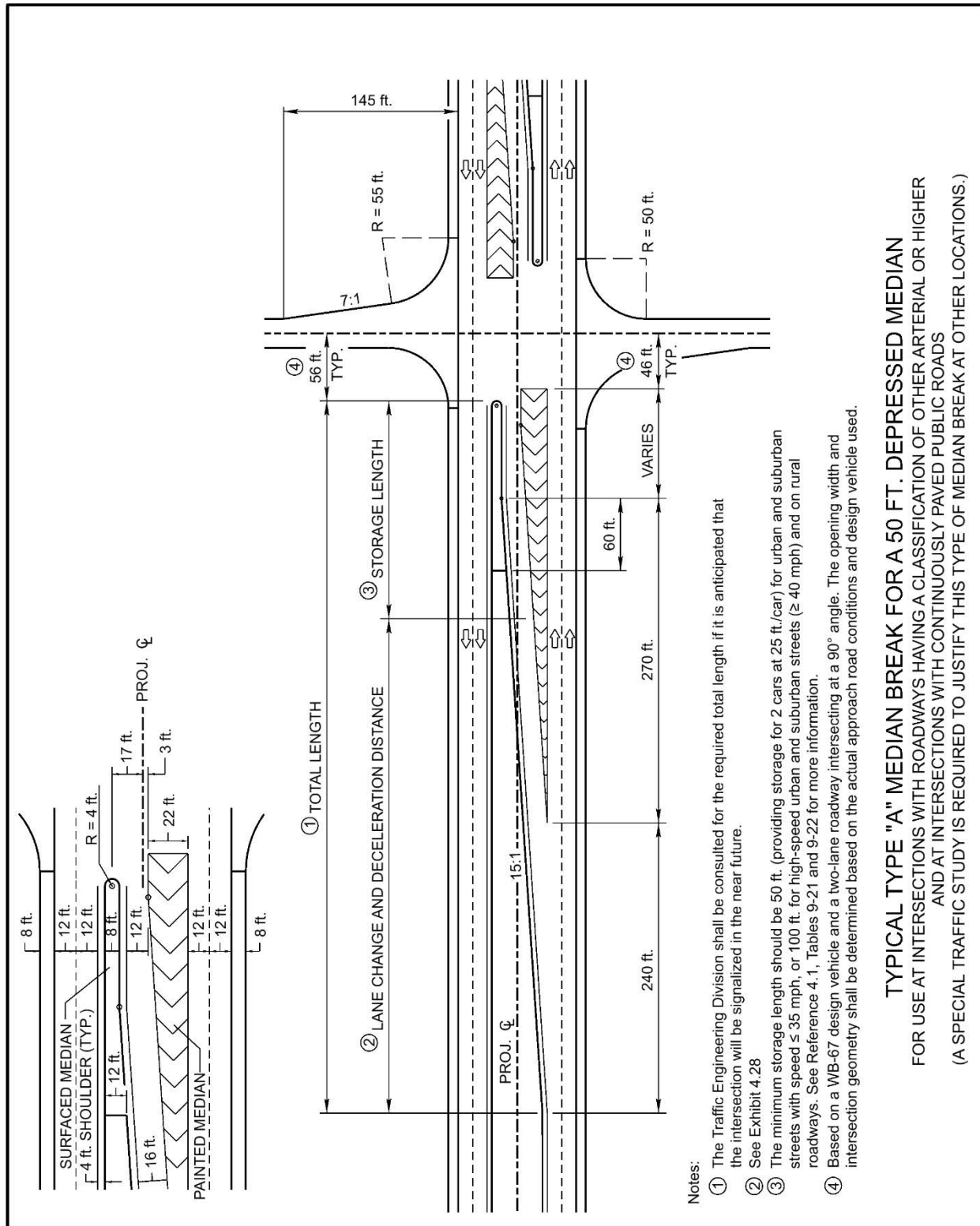
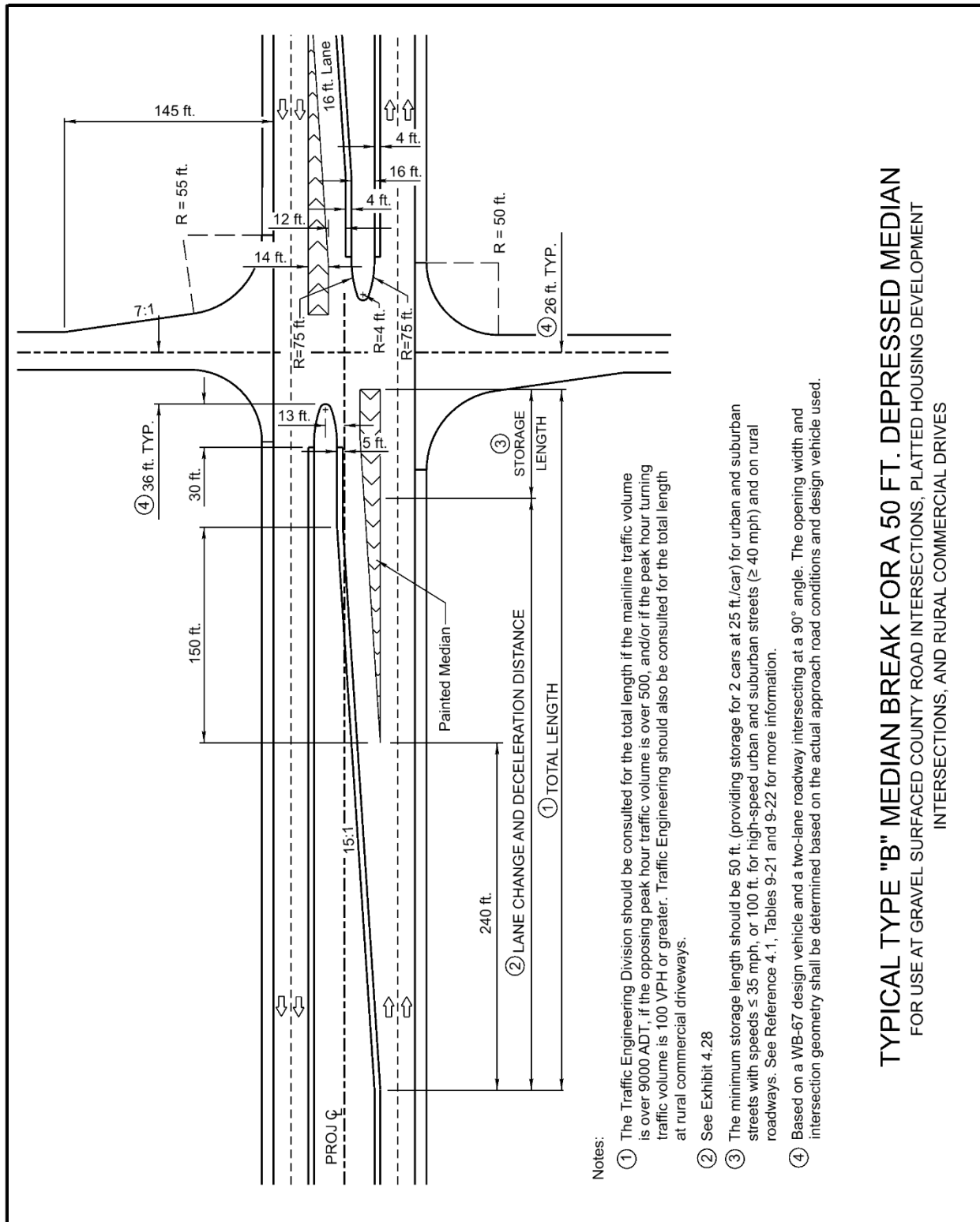


Exhibit 4.35 Typical Type A Median Break (50 Foot Depressed Median)



Notes:

- ① The Traffic Engineering Division should be consulted for the total length if the mainline traffic volume is over 9000 ADT, if the opposing peak hour traffic volume is over 500, and/or if the peak hour turning traffic volume is 100 VPH or greater. Traffic Engineering should also be consulted for the total length at rural commercial driveways.
- ② See Exhibit 4.28
- ③ The minimum storage length should be 50 ft. (providing storage for 2 cars at 25 ft./car) for urban and suburban streets with speeds  $\leq$  35 mph, or 100 ft. for high-speed urban and suburban streets ( $\geq$  40 mph) and on rural roadways. See Reference 4.1, Tables 9-21 and 9-22 for more information.
- ④ Based on a WB-67 design vehicle and a two-lane roadway intersecting at a 90° angle. The opening width and intersection geometry shall be determined based on the actual approach road conditions and design vehicle used.

**TYPICAL TYPE "B" MEDIAN BREAK FOR A 50 FT. DEPRESSED MEDIAN**  
 FOR USE AT GRAVEL SURFACED COUNTY ROAD INTERSECTIONS, PLATTED HOUSING DEVELOPMENT  
 INTERSECTIONS, AND RURAL COMMERCIAL DRIVES

Exhibit 4.36 Typical Type B Median Break (50 Foot Depressed Median)



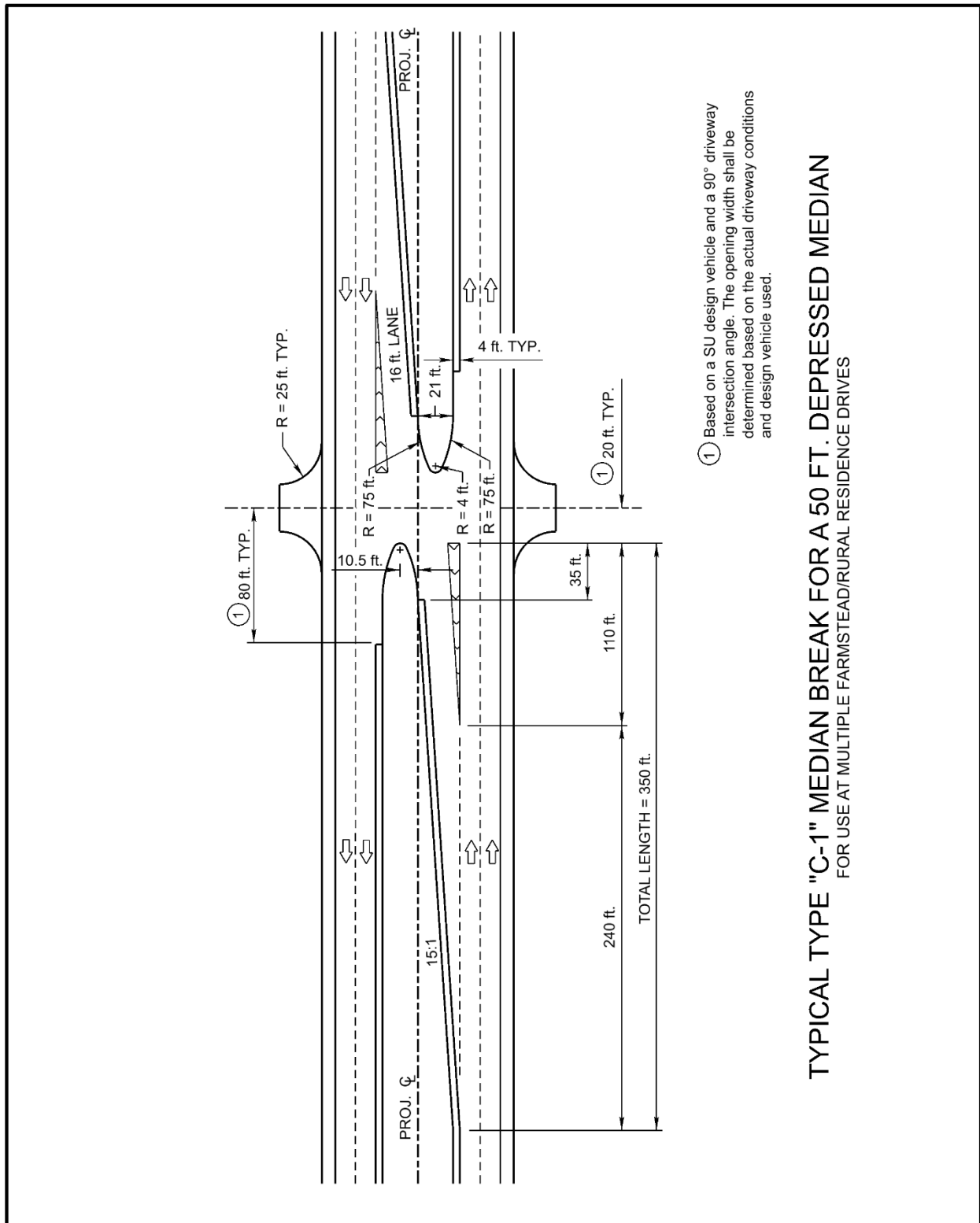


Exhibit 4.37 Typical Type C-1 Median Break (50 Foot Depressed Median)

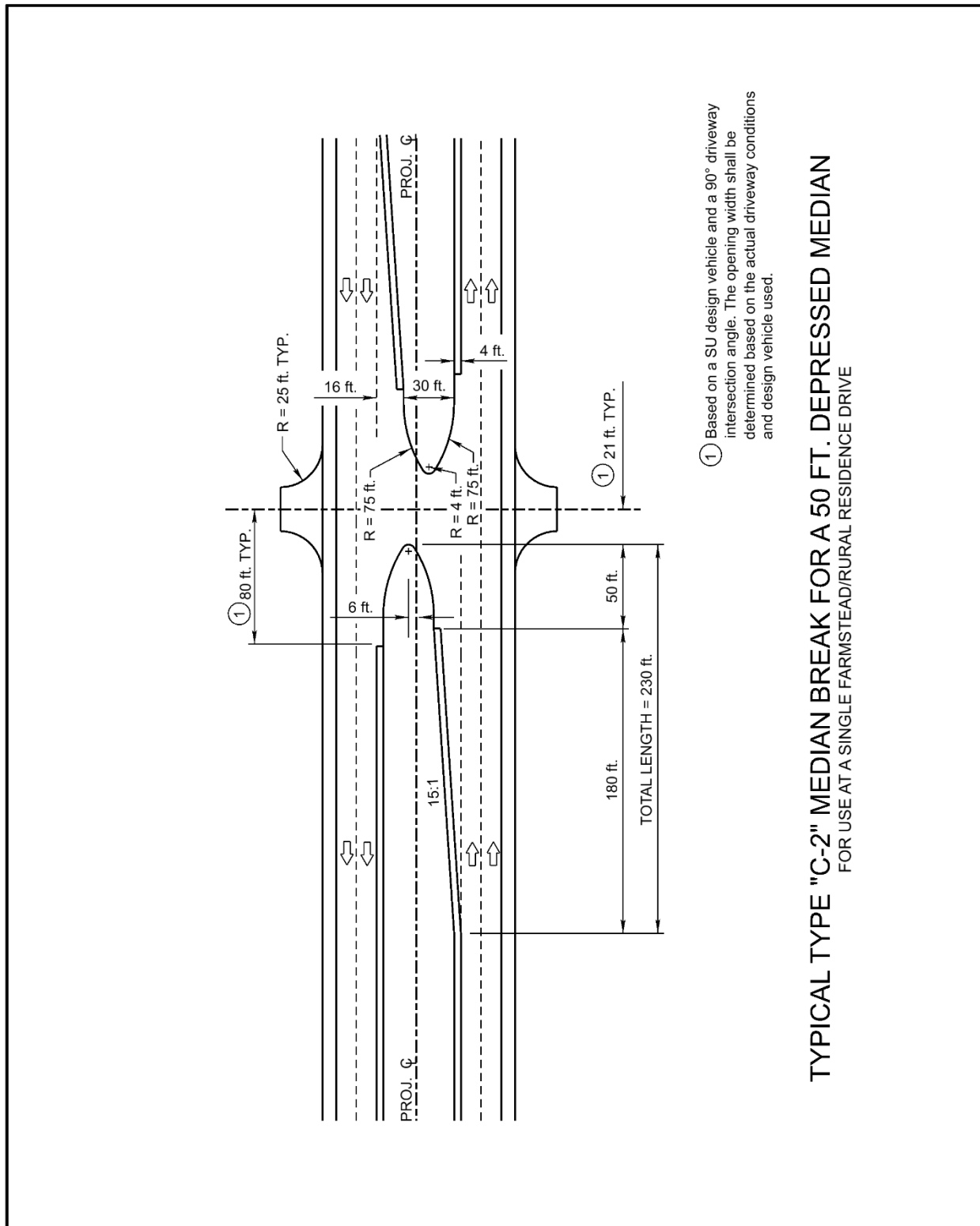


Exhibit 4.38 Typical Type C-2 Median Break (50 Foot Depressed Median)

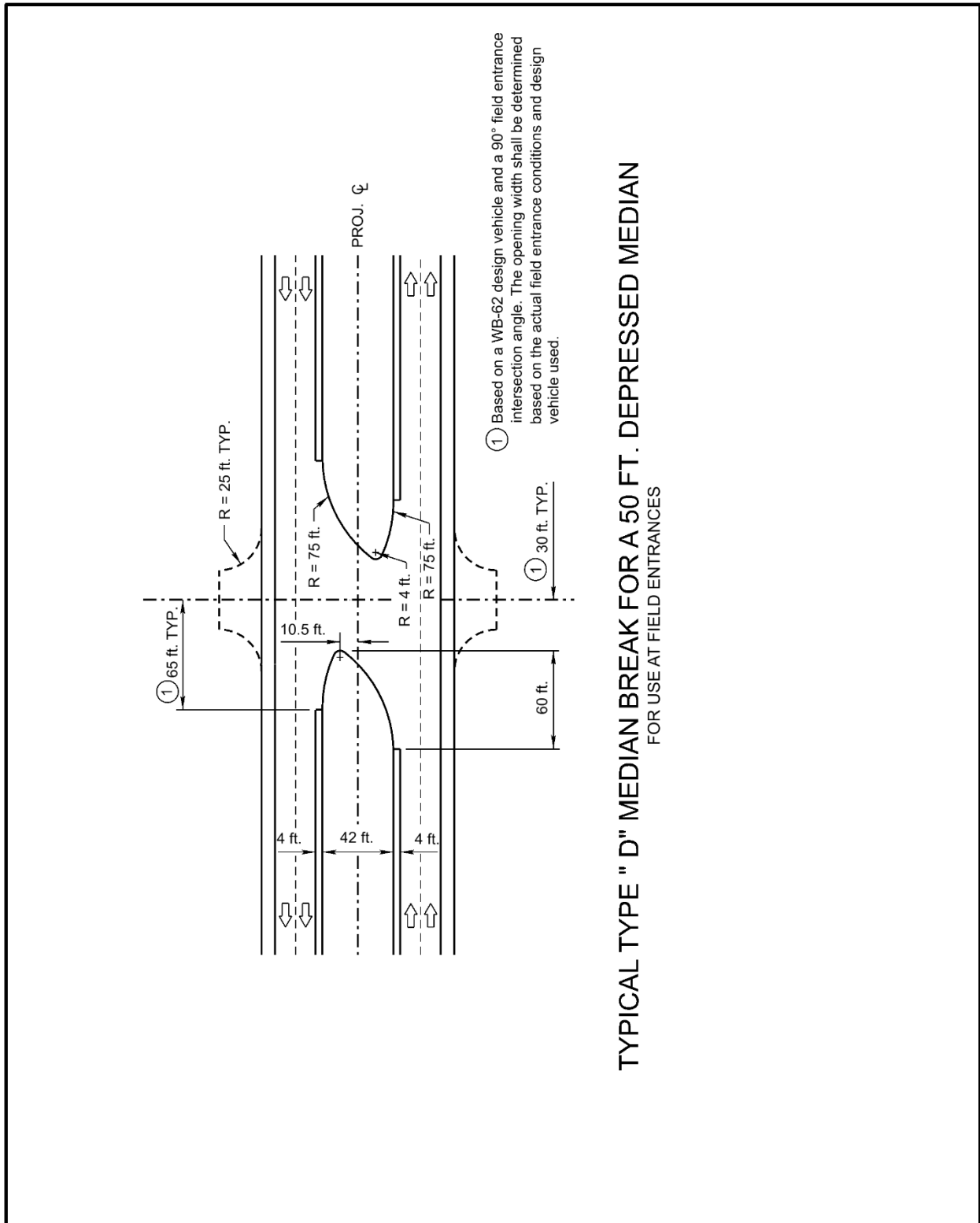


Exhibit 4.39 Typical Type D Median Break (50 Foot Depressed Median)

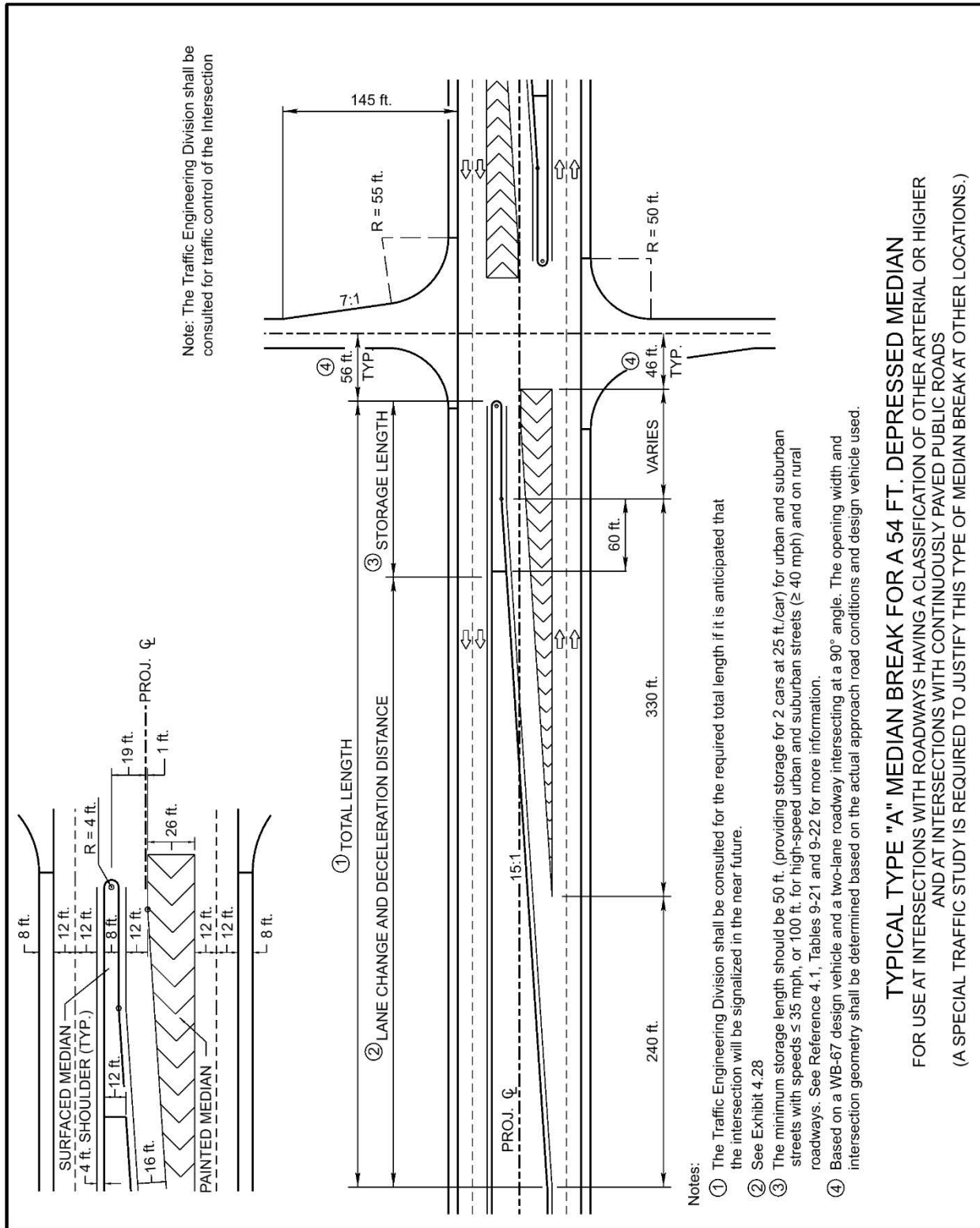
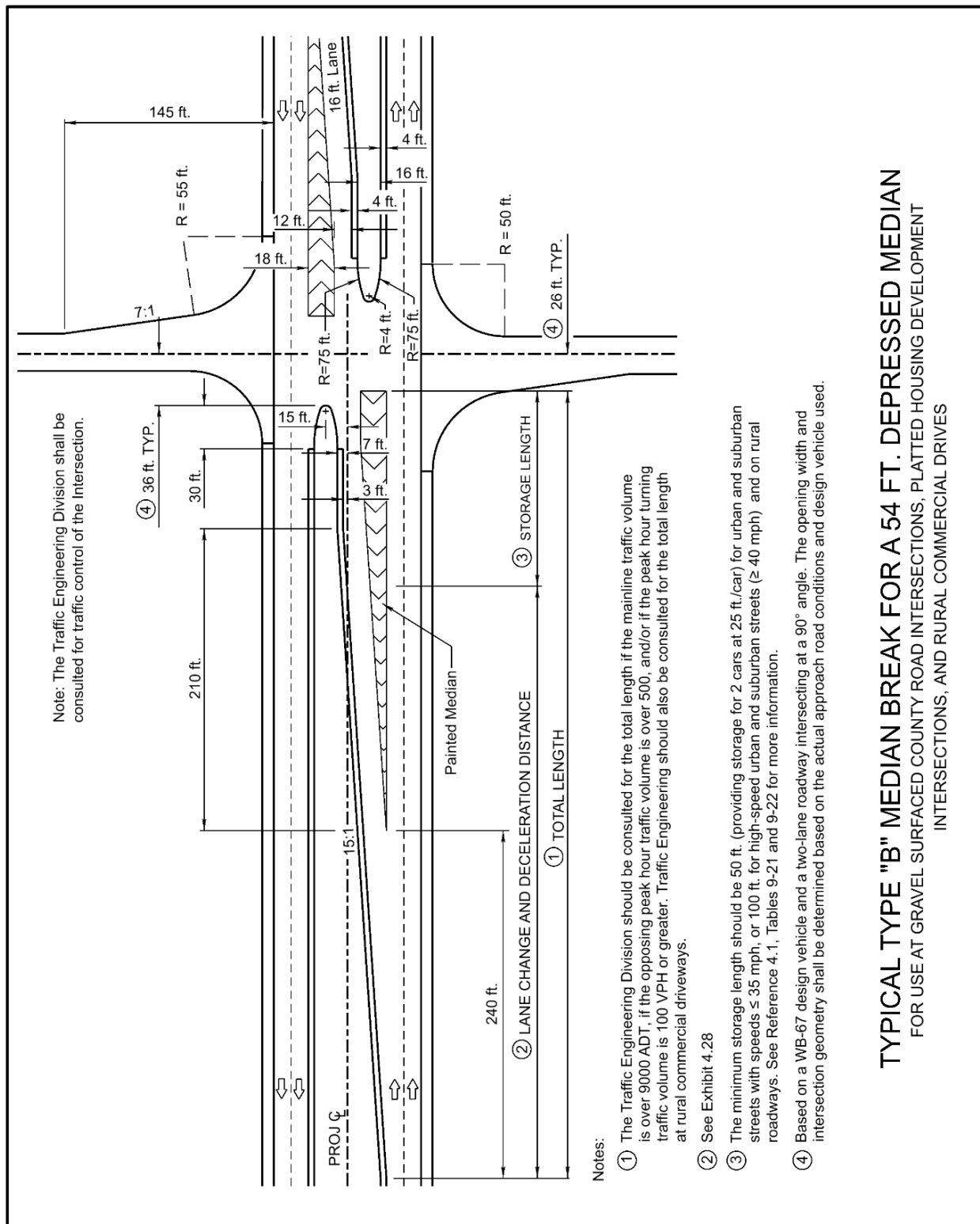


Exhibit 4.40 Typical Type A Median Break (54 Foot Depressed Median)



**TYPICAL TYPE "B" MEDIAN BREAK FOR A 54 FT. DEPRESSED MEDIAN**  
 FOR USE AT GRAVEL SURFACED COUNTY ROAD INTERSECTIONS, PLATTED HOUSING DEVELOPMENT  
 INTERSECTIONS, AND RURAL COMMERCIAL DRIVES

Exhibit 4.41 Typical Type B Median Break (54 Foot Depressed Median)

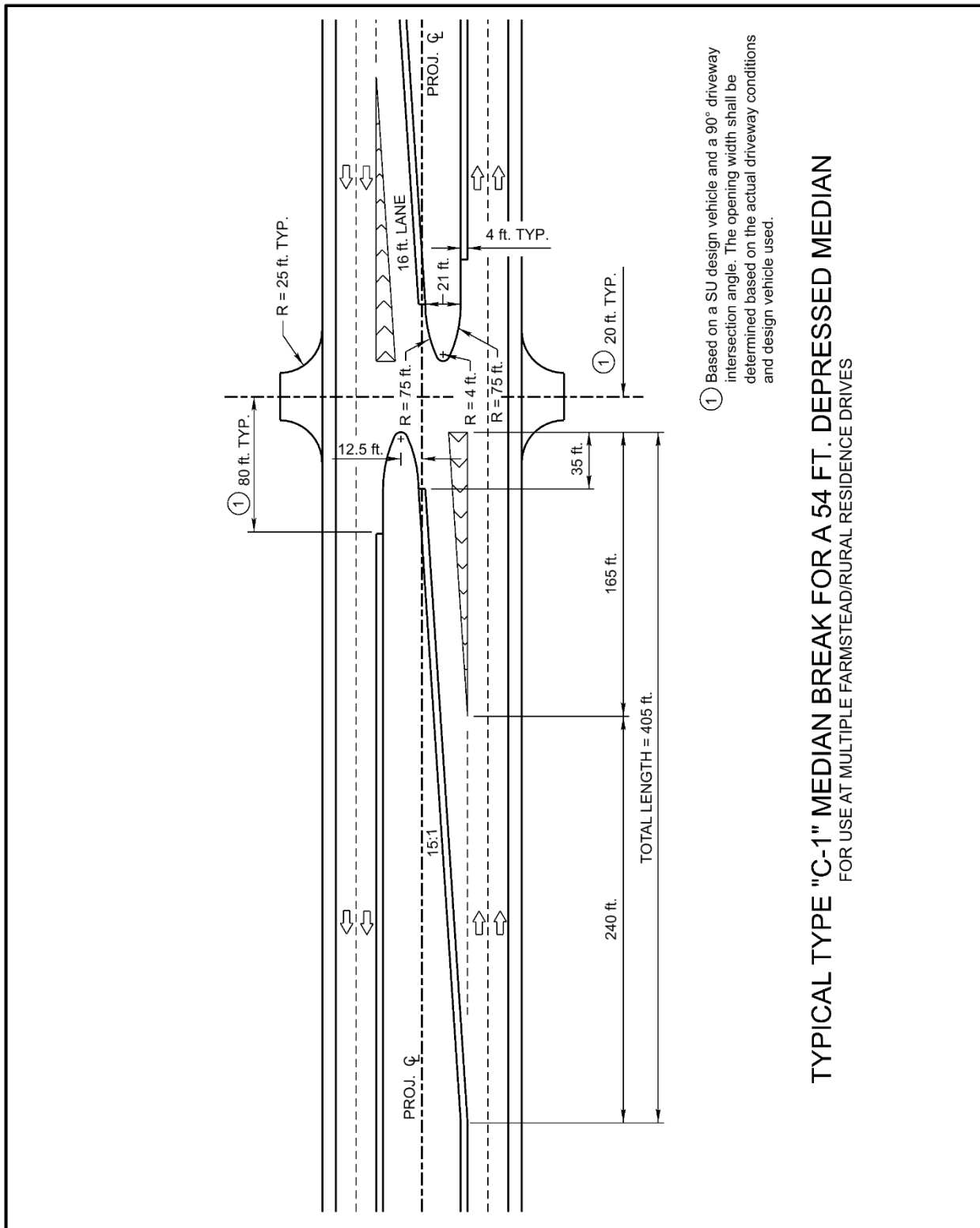


Exhibit 4.42 Typical Type C-1 Median Break (54 Foot Depressed Median)

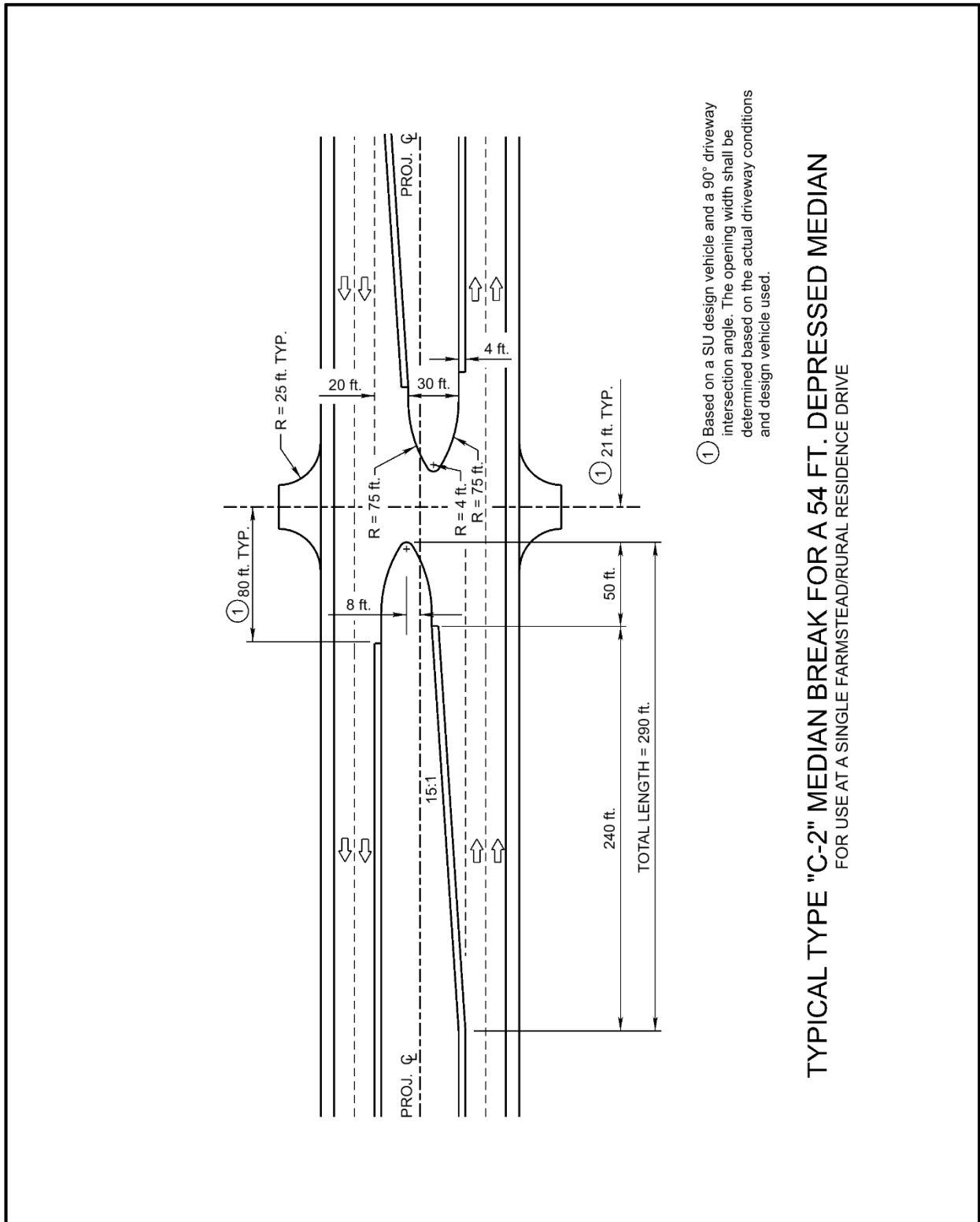


Exhibit 4.43 Typical Type C-2 Median Break (54 Foot Depressed Median)

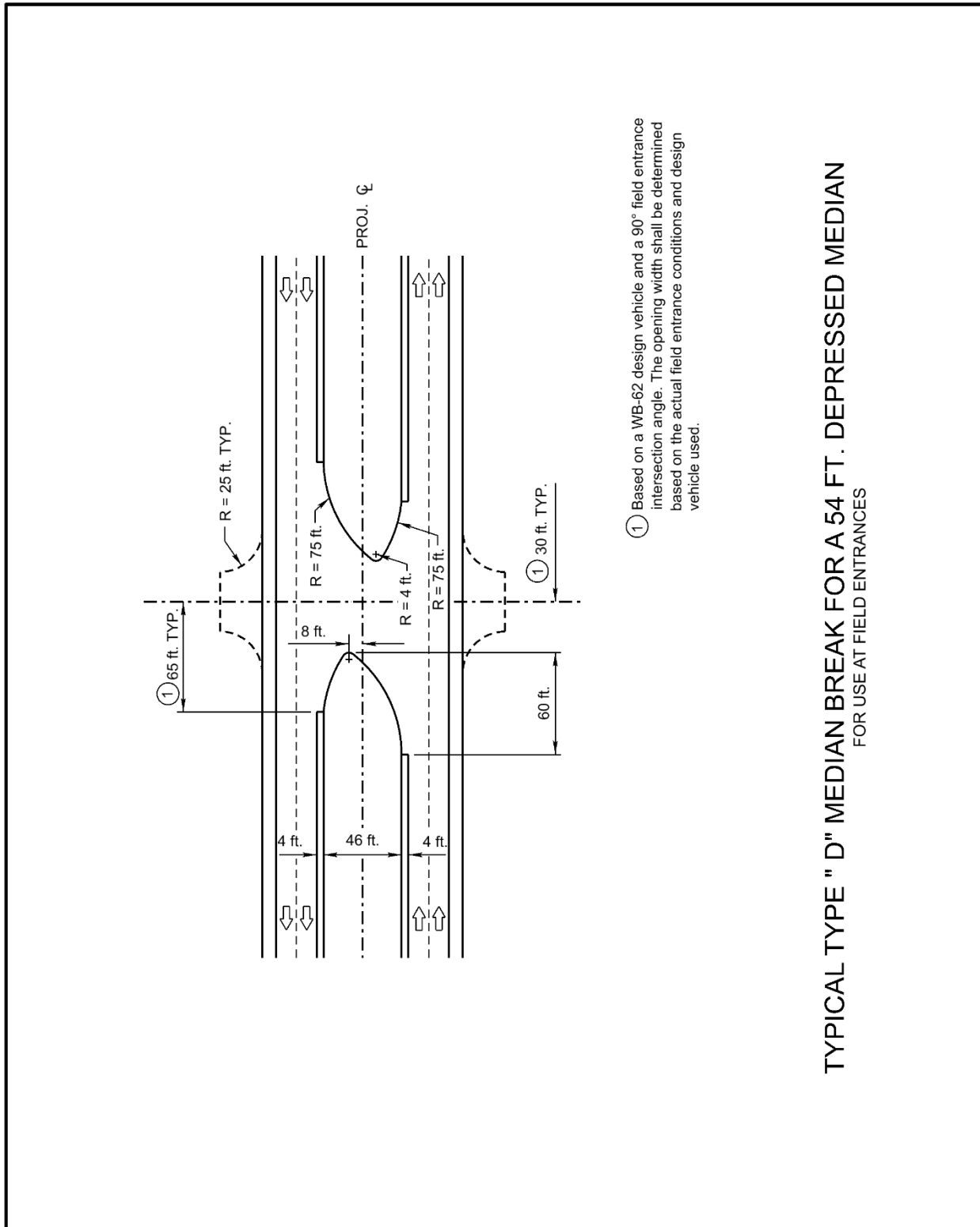


Exhibit 4.44 Typical Type D Median Break (54 Foot Depressed Median)



## 6. REFERENCES

- 4.1 American Association of State Highway and Transportation Officials, A Policy on Geometric Design of Highways and Streets (the *Green Book*), Washington, DC, 2018.
- 4.2 U.S. Department of Transportation, Federal Highway Administration, Manual on Uniform Traffic Control Devices for Streets and Highways (*MUTCD*), Washington, DC, 2009. (<https://dot.nebraska.gov/business-center/contractor/mutcd/>)
- 4.3 State of Nebraska, Supplement to the Manual on Uniform Traffic Control Devices (*NE-MUTCD*), 2011 (<https://dot.nebraska.gov/business-center/contractor/mutcd/>)
- 4.4 Schurr, Karen, et al, "Appropriate Design Speed for Horizontal Curves Approaching a Stop", NDOT Research Project Number SPR-PL-1(038) P534, University of Nebraska-Lincoln, September 2004 ([Appropriate Design Speed for Horizontal Curves Approaching a Stop : Final Report \(2004\) \(nebraska.gov\)](#))
- 4.5 Transportation Research Board, "Impacts of Access Management Techniques", NCHRP Report 420, Washington, DC, 1999
- 4.6 Transportation Research Board, National Research Council, Highway Capacity Manual, Special Report 209, Washington, DC, Current Edition.
- 4.7 Board of Public Roads Classifications and Standards, Nebraska Minimum Design Standards (*MDS*), Current Edition. (<https://dot.nebraska.gov/media/1z1n5kmb/nac-428-rules-regs-nbcs.pdf>)
- 4.8 McCoy, Patrick, Eric Tripi and James Bonneson, "Guidelines for Realignment of Skewed Intersections," NDOT Research Project Number RES1 (0099) P471 Transportation Research Studies, University of Nebraska - Lincoln, June 1994.
- 4.9 Architectural and Transportation Compliance Board, Accessibility Guidelines for Pedestrian Facilities in the Public Right-of-Way (*Accessibility Guidelines*), Washington, D.C., 2023 (<https://www.federalregister.gov/documents/2023/08/08/2023-16149/accessibility-guidelines-for-pedestrian-facilities-in-the-public-right-of-way>)
- 4.10 American Association of State Highway and Transportation Officials, Guide for Development of Bicycle Facilities, Washington, DC, 1999. ([Guide for the Development of Bicycle Facilities \(dot.gov\)](#))
- 4.11 McCoy, Patrick, et. al., "Guidelines for Free Right-Turn Lane at Unsignalized Intersections on Rural Two-Lane Highways," TRP-02-32, NDOT Research Project Number RES 1(0099) P603, University of Nebraska - Lincoln, March 1995.
- 4.12 Nebraska Department of Transportation, Access Control Policy to the State Highway System, June 1993. (<https://dot.nebraska.gov/media/v45nhanu/access-control-policy.pdf>)

- 4.13 U.S. Department of Transportation, Federal Highway Administration, Alternative Intersections/Interchanges: Informational Report (AIIR), Washington, DC, 2009. (<https://www.fhwa.dot.gov/publications/research/safety/09060/09060.pdf>)
- 4.14 Nebraska Department of Transportation, Standard/Special Plan Book (Standard Plans), Current Edition (<https://dot.nebraska.gov/business-center/design-consultant/stand-spec-manual/>)
- 4.15 Nebraska Department of Transportation, Drainage Design and Erosion Control Manual (Drainage Manual), Current Edition. (<https://dot.nebraska.gov/business-center/design-consultant/rd-manuals/>)
- 4.16 Nebraska Department of Transportation, Standard Specifications for Highway Construction (Spec Book), 2017. (<https://dot.nebraska.gov/media/g4qp4y0d/2017-specbook.pdf>)
- 4.17 Nebraska Department of Transportation, So You Want Access to the Highway?, Current Edition. (<https://dot.nebraska.gov/media/jeseiwu0/access-hwy.pdf>)
- 4.18 Transportation Research Board, “Roundabouts: An Informational Guide – Second Edition”, NCHRP Report 672, Washington, DC, 2010 (<https://www.trb.org/Main/Blurbs/164470.aspx>)
- 4.19 Schurr, Karen, Foss, Timothy Jr., “Offset Right-Turn Lanes for Improved Intersection Sight Distance”, NDOT Research Project Number SPR-P1(06) P592, ([Offset Right-Turn Lanes for Improved Intersection Sight Distance Final Report \(unl.edu\)](#)), University of Nebraska-Lincoln, June 2010
- 4.20 Khattak Aemal Phd, Kang, Yashu, “Offset Right-Turn Lanes on State Highway Systems”, NDOT Research Report No. 26-1121-0030-001, (<m060-offset-right-turn-lanes.pdf> ([nebraska.gov](https://dot.nebraska.gov))), University of Nebraska-Lincoln, December 2018

Chapter Five presents guidance for the design of New and Reconstructed projects; design guidance for 3R projects is provided in Chapter Seventeen.

## Chapter Five

# Interstates, Grade Separations, and Interchanges

Primary sources for design guidance for Interstates are the **American Association of State Highway and Transportation Officials (AASHTO)** publications A Policy on Design Standards – Interstate System (Ref. 5.1) and A Policy on Geometric Design of Highways and Streets (the *Green Book*) (Ref. 5.2). Design details specific to the design of Interstates by the **Nebraska Department of Transportation (NDOT)** are presented in this chapter. Refer to the design details and information presented in the remaining chapters of this manual for **NDOT** guidance not presented here.

The primary guide for grade separation and interchange design for **NDOT** is the *Green Book* (Ref. 5.2). This chapter presents a general overview of and **NDOT** variations on the *Green Book* guidance.

Additional resources used by **NDOT** include the **Transportation Research Board's (TRB's) Highway Capacity Manual** (Ref. 5.3) and the **Federal Highway Administration's (FHWA's) Manual on Uniform Traffic Control Devices (MUTCD)**, Ref. 5.4 (<https://dot.nebraska.gov/business-center/contractor/mutcd/>).

1. **INTERSTATE SYSTEM**  
(<https://www.fhwa.dot.gov/programadmin/interstate.cfm>)

The Dwight D. Eisenhower National System of Interstate and Defense Highways (Interstate System) is a national defense system of highways consisting of routes built to uniform geometric and construction standards. This system connects the principal metropolitan areas, cities, and industrial centers of the United States and, to the greatest extent possible, connects the border routes of continental importance with Canada and Mexico. A map showing the Interstate routes in Nebraska is available on the internet at [Interstate And Defense Highway System \(nebraska.gov\)](http://nebraska.gov).

1.A. **Interstate Design Values**

The **NDOT** minimum design values for use on the Interstate System are in Chapter 2 of the Nebraska Administrative Code, Title 428 (MDS) (Ref. 5.5) (<https://dot.nebraska.gov/media/1z1n5kmb/nac-428-rules-regs-nbcs.pdf>). *Green Book* (Ref. 5.2) minimum design values are in Appendix H, “AASHTO Minimum Design Guidance”, of this manual.

1.B **Design Controls**

1.B.1 **Design Year**

The design year for New and Reconstructed projects and for 3R projects is the year of initial construction plus 20 years.

1.B.2 **Design Speed**

The desirable design speed is five mph greater than the anticipated posted speed limit for the roadway. For 3R projects the design speed to be used is the speed limit determined by the **Traffic Engineering Division (Traffic Engineering)** to be posted at the completion of construction.

1.B.3 **Design Vehicle**

The design vehicle for Interstate and ramp terminals is the WB-67. See Chapter Four: Intersections, Driveways, and Channelization, Section 1.C.5, “Design Vehicle”, of this manual for additional information.

1.C **Alignment**

For design guidance regarding horizontal and vertical alignment, see Chapter Three: Roadway Alignment, of this manual.

#### **1.D      The Typical Interstate Cross-Section**

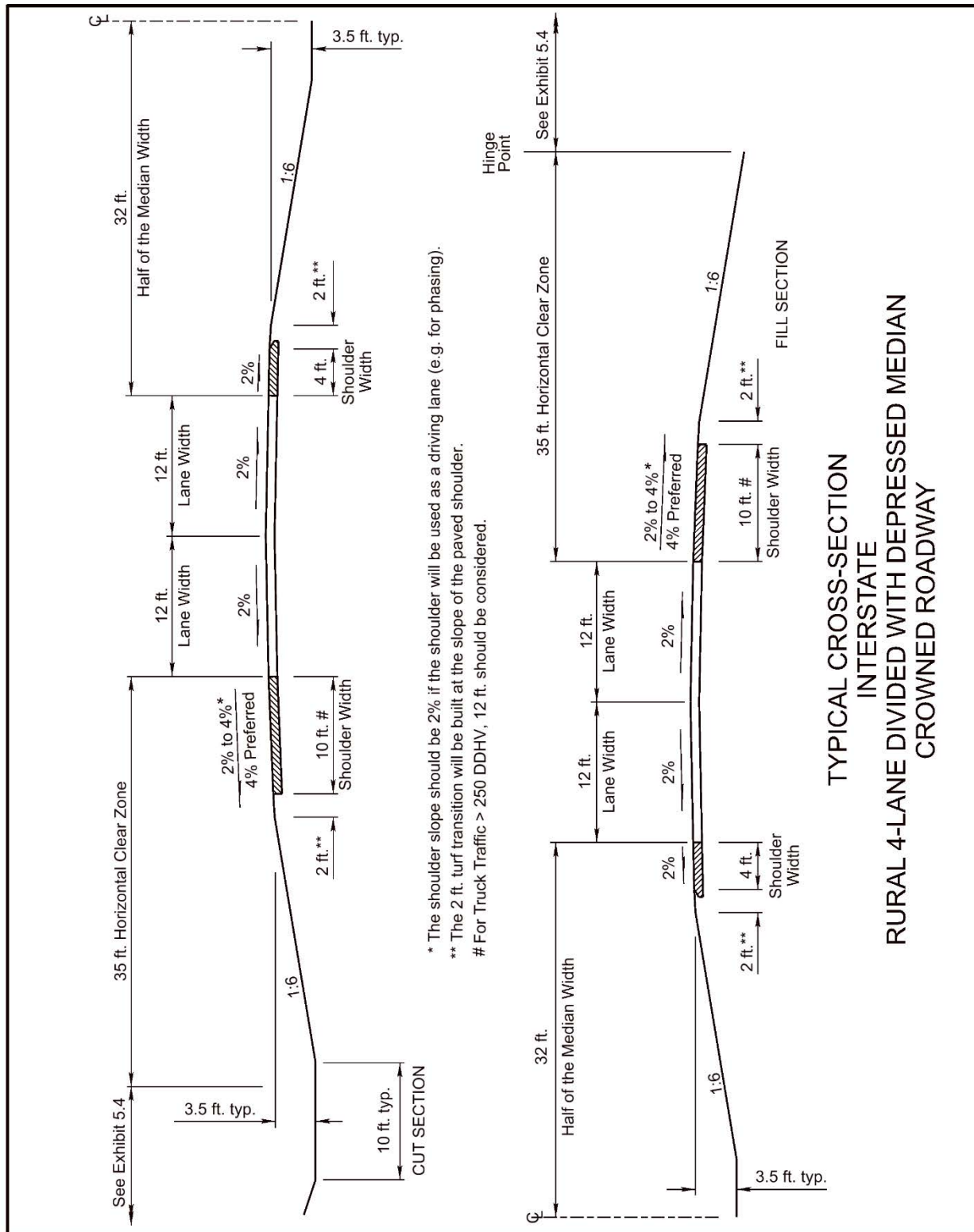
Typical Rural Interstate cross-sections are shown in EXHIBITS 5.1 THROUGH 5.3. The desirable depressed median width for an Interstate is 64 feet (See Chapter Four: Intersections, Driveways, and Channelization, Section 5.B.3, “Median Width” of this manual for additional information). A beveled edge will be installed on the inside (median) shoulders which are less than six feet in width (See Chapter Six: The Typical Roadway Cross-Section, Section 2.C, “Beveled Edge” of this manual for additional information). There are no typical cross-sections for Suburban, Urban, and Urban Core Interstates due to the greater variety in the number of lanes. For additional information, see Chapter Six: The Typical Roadway Cross-Section of this manual.

#### **1.E      Earthwork**

Earthwork for Interstates, freeways, and expressways should be calculated based on the phased construction of the directional lanes; see Chapter Seven: Earthwork, Section 2, “Staged Construction/Phasing”, of this manual for guidance.

#### **1.F      Interstate Surfacing**

The minimum pavement thickness of Portland Cement Concrete Pavement on the Interstate System is 12 inches. Shoulders will be built at full depth. Rumble strips will be constructed on the shoulders, including the median shoulders, for all Rural Interstate projects, either New, Reconstructed, or 3R. See Chapter Eight: Surfacing of this manual for additional information.



\* The shoulder slope should be 2% if the shoulder will be used as a driving lane (e.g. for phasing).  
 \*\* The 2 ft. turf transition will be built at the slope of the paved shoulder.  
 # For Truck Traffic > 250 DDHV, 12 ft. should be considered.

**Exhibit 5.1 Typical Section – Rural Four-Lane Divided Interstate with Depressed Median (Crowned Roadway)**

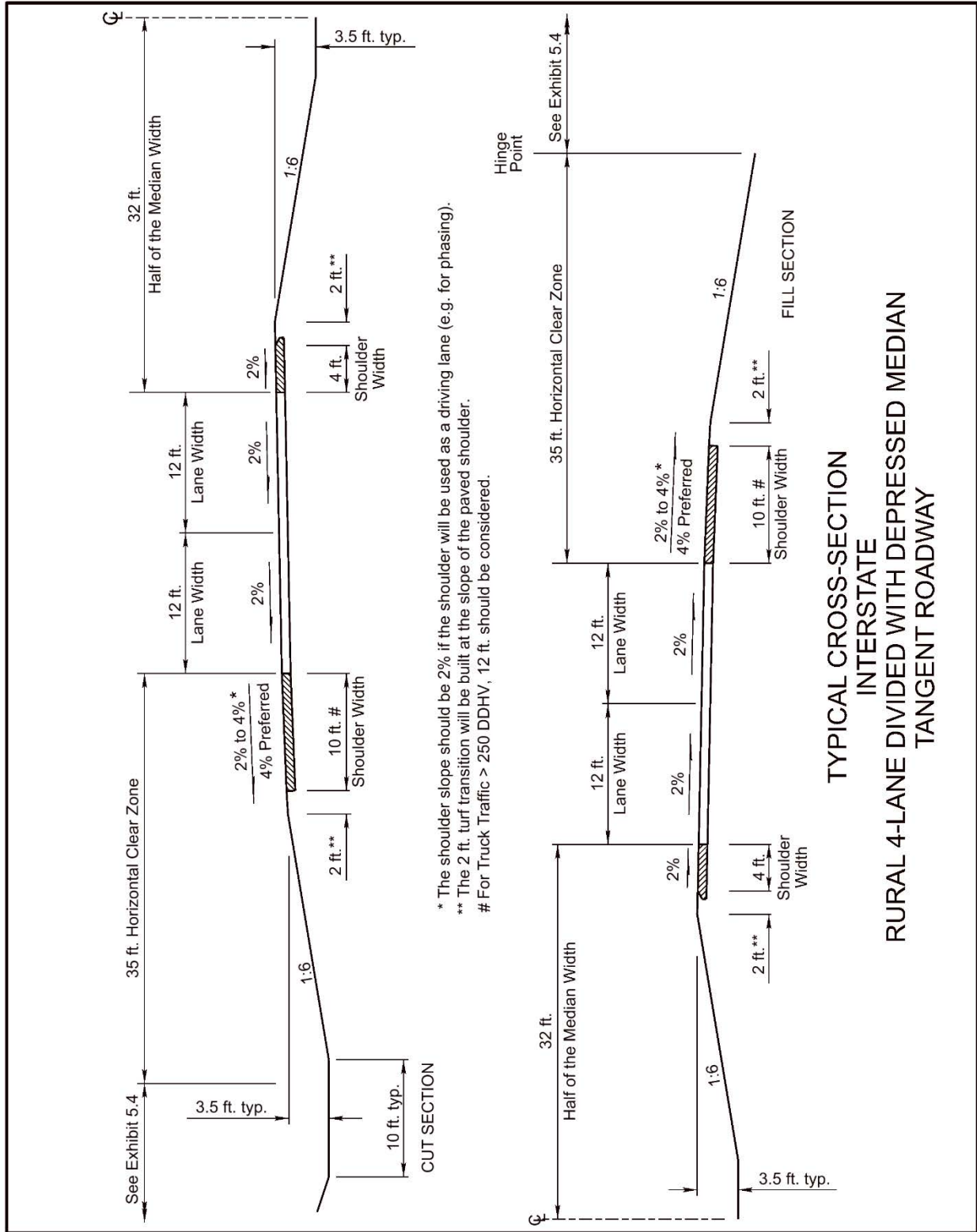
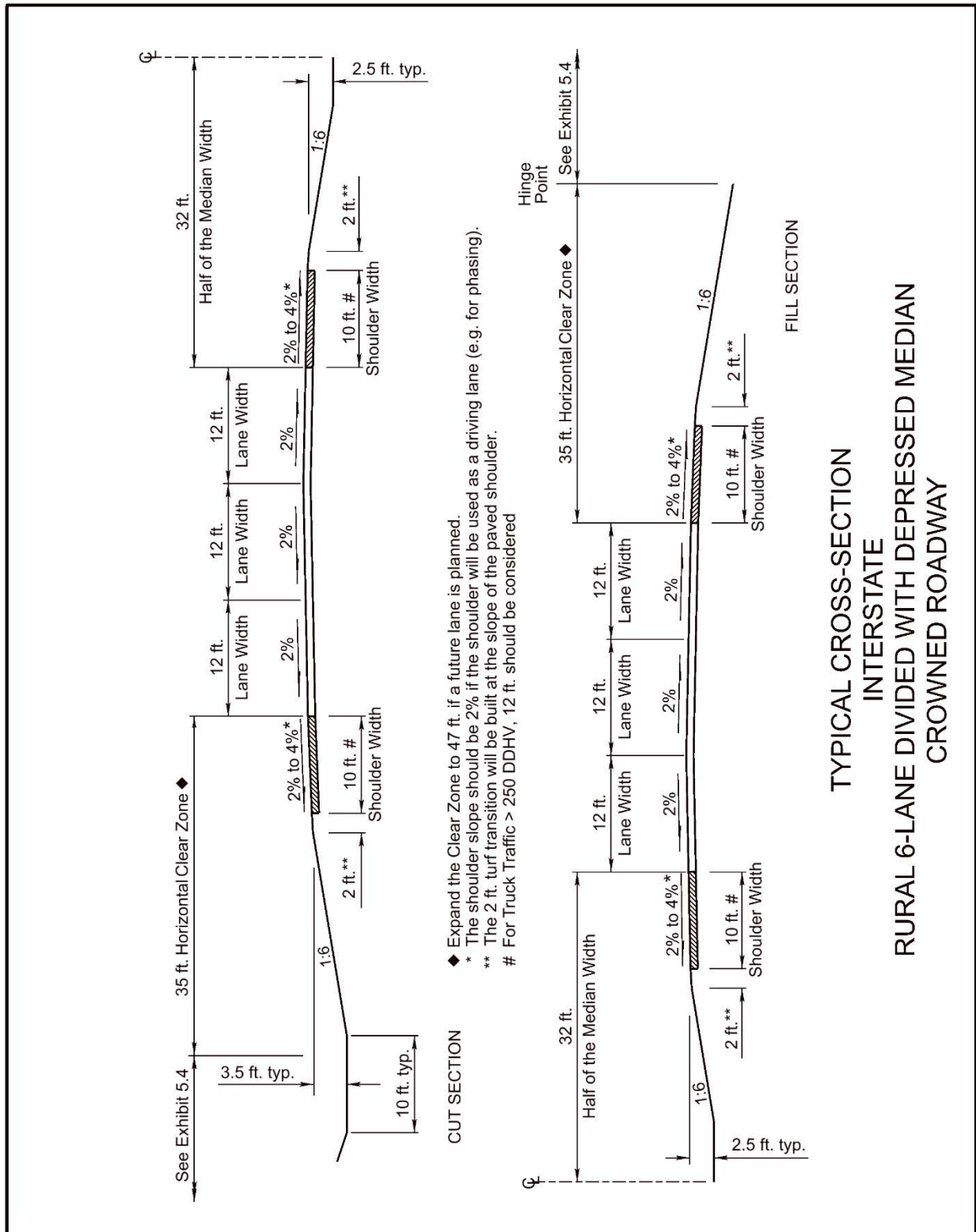


Exhibit 5.2 Typical Section – Rural Four-Lane Divided Interstate with Depressed Median (Tangent Roadway)



**Exhibit 5.3 Typical Section – Rural Six-Lane Divided Interstate with Depressed Median (Crowned Roadway)**



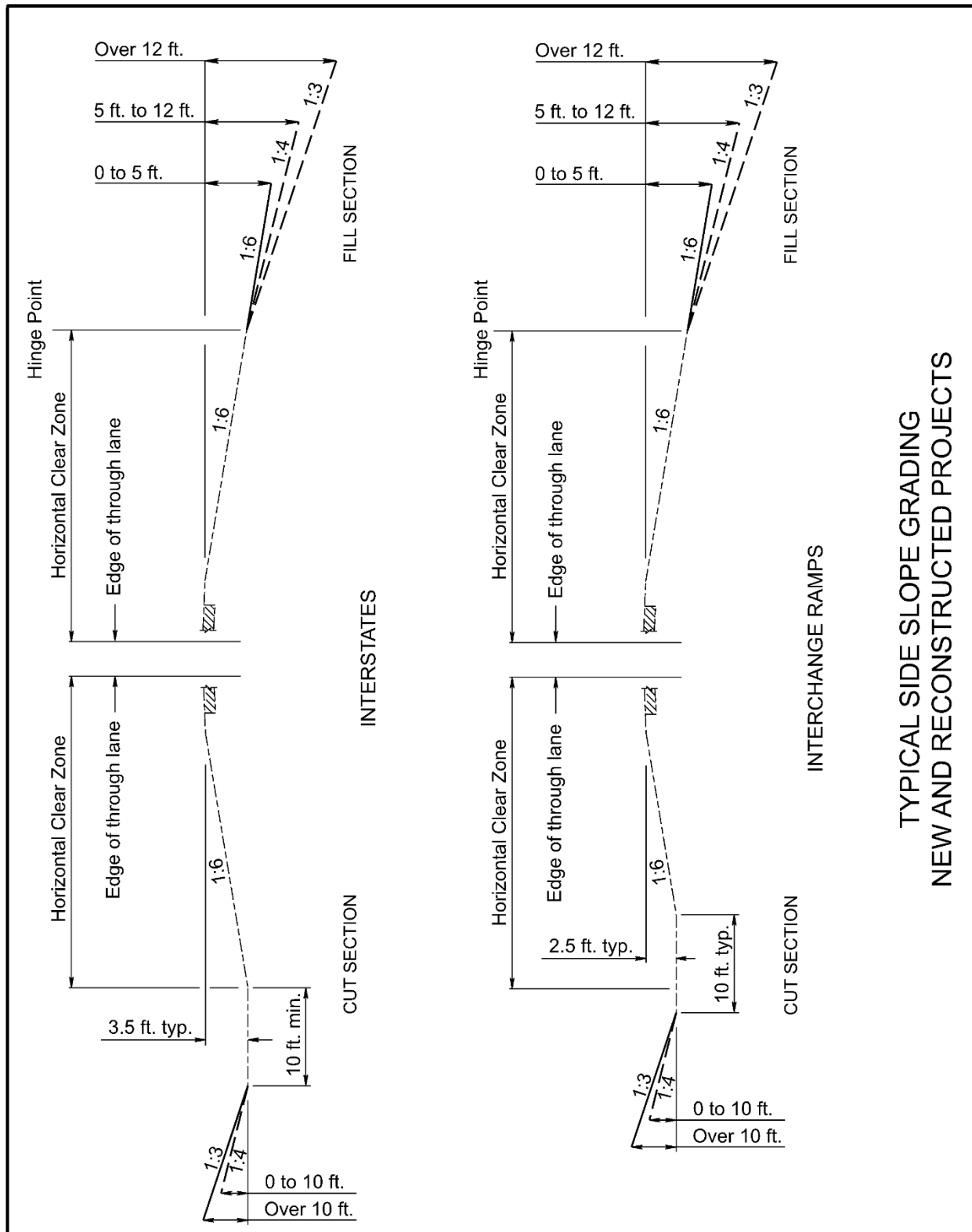


Exhibit 5.4 Typical Side Slopes for New and Reconstructed Interstates and Interchange Ramps

## 1.G Guardrail and Roadside Barriers

A Guardrail End Treatment, Type I is Test Level 3 approved and shall be used on Interstate projects. See Chapter Nine: Guardrail and Roadside Barriers of this manual for additional information.

## 1.H Miscellaneous Interstate Design Issues

### 1.H.1 Fencing

Interstates shall be fenced. The fencing is run along the right-of-way line according to the Standard Specifications for Highway Construction (Spec Book), Section 9.10 (Ref. 5.6) (<https://dot.nebraska.gov/media/g4qp4y0d/2017-specbook.pdf>). At rural interchanges, fencing should extend 500 feet along the crossroad from the ramp terminal. Interstate fencing shall be included in the construction items; the roadway designer shall include this fencing in the **Roadway Design** PS&E Estimate (See the Design Process Outline, Phase 7, “Plan Package”, Cost Estimate 50, <https://dot.nebraska.gov/business-center/design-consultant/>). See Chapter Ten: Miscellaneous Design Issues, Section 6, “Fencing” and Chapter Twelve: Cost Estimating & Funding, EXHIBIT 12.1 and Section 7.G, “Construction Items”, of this manual for additional information.

### 1.H.2 Utilities

Longitudinal utility occupancy inside the fenced right-of-way of an Interstate is considered only as a “last resort” when no other feasible route can be followed by the utility facility or when such utility facility exclusively serves a highway facility. Specific details for each installation will be determined at the time the utility occupancy is authorized. See Chapter Ten: Miscellaneous Design Issues, Section 12.D, “Utility Accommodation on State Highway Right-of-Way”, of this manual for additional information.

### 1.H.3 Water Quality

NDOT is responsible for maintaining the Stormwater Treatment Facilities (STFs) on Interstate and freeway projects (See Chapter Three: Stormwater Treatment of the Drainage Design and Erosion Control Manual, Ref. 5.8) (<https://dot.nebraska.gov/media/mecfz1tv/f-chapter-3-stormwater-treatment.pdf>).

### 1.H.4 Left-in-Place Median Crossovers

Selected Interstate median crossovers will be retained following an improvement. These crossovers will be available for traffic phasing on future projects, first responder access, detouring traffic around closed lanes (e.g. accidents, flooded lanes), etc. The median crossovers to be left-in-place will be determined on a case-by-case basis, taking into consideration such items as scope of work, traffic control, and traffic volumes.

Design guidance for a left-in-place median crossover includes:

- A desirable design speed of 65 mph
- A paved width of 14 feet per lane
- A concrete pavement depth of 10 inches
- Drainage patterns and structures designed for the retention of the crossover

### 1.H.5 Rest Areas and Weigh Stations

**Roadway Design** is not responsible for the design of rest areas or weigh stations, but a designer may be called upon for assistance in the design of the ramps, parking areas, and scale platform. The designer will coordinate the design with the **Capital Facilities Section** of the **Operations Division, Traffic Engineering**, and other **Divisions/Sections** or consultants as required by the project.

### 1.I Interstate Plans

Large Scale Plan (J) Sheets are normally used for Interstate projects. See Chapter Eleven: Highway Plans Assembly, Section 4.J, of this manual for additional information.

### 1.J Right-Of-Way/Access Control

Access control is a restriction of the number and location of access points along a highway. The Interstate, freeway and expressway (access only at interchanges) systems are multi-lane highways for through traffic with full control of access and no at-grade intersections. Access to the facility is allowed only at interchange locations. Access control along intercepting roads should be acquired a minimum of 660 feet beyond the interchange ramp terminal (See EXHIBIT 5.5). See Chapter Fifteen: Right-of-Way, Section 3, "Access Control" of this manual for additional information.

### 1.K Interstate Pedestrian and Bicycle Facilities

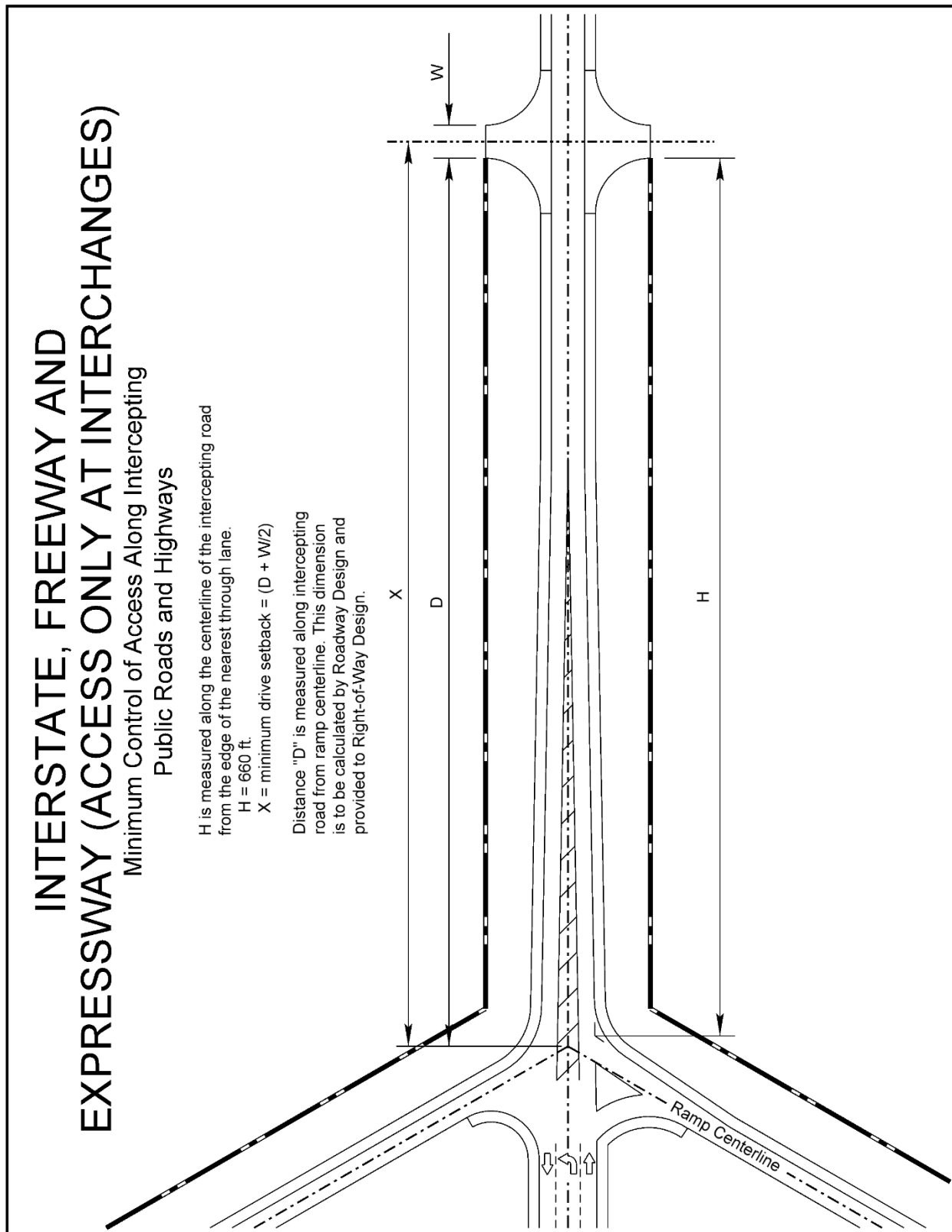
By statute, the **State of Nebraska** does not allow bicycles and pedestrians on the Interstate System or on freeways. For additional information, see the Reissue Revised Statutes of Nebraska 60-6,142 (<https://nebraskalegislature.gov/laws/statutes.php?statute=60-6,142>) and 60-6,144 (<https://nebraskalegislature.gov/laws/statutes.php?statute=60-6,144>). Section 2.G of this chapter addresses pedestrian access at interchanges.

### 1.L Drainage Design

Interstate drainage structures (culverts, storm sewers, and median drainage structures) will be designed to a 50-year Design Storm Frequency except for Intercepting Dike/Backslope Drop Pipes (25 year) and Temporary Structures (duration ≤ two years, two-year design storm). For additional information, see Chapter One: Drainage of the **NDOT Drainage Design and Erosion Control Manual** (Ref. 5.8).

### 1.M 3R Interstate Projects

See Chapter Seventeen: Resurfacing, Restoration and Rehabilitation (3R) Projects, Section 1.D, of this manual.



**Exhibit 5.5 Control of Access Along Intercepting Public Roads and Highways Interstate, Freeway and Expressway (Access only at Interchanges)**

## 2. GRADE SEPARATIONS AND INTERCHANGES

A grade separation is by definition a crossing of two highways (or a highway and a railroad line) at different levels, separating the through traffic movements of intersecting roadways while not providing access for turning traffic. To facilitate design and construction of possible future interchanges, the designer of a grade separation should consider including the interchange criteria for grade, alignment, and sight distance into the design of the grade separation.

An interchange is a system of interconnected roadways, consisting of one or more grade separations with connecting ramps, designed to increase highway capacity and to reduce or eliminate traffic conflicts. Interchanges separate through traffic movements and provide for turning traffic movements. An interchange may be a “System Interchange”, used to connect two or more freeways, or a “Service Interchange”, used to connect a freeway to a lower classification roadway. Interchanges are built on roadways with complete control of access (See Section 1.J, “Right-of-Way/Access Control”, of this chapter).

The **Traffic Engineering Division (Traffic Engineering)** assists in the development of interchange type and design. The types and design of grade separations and interchanges is a function of many factors including, but not limited to:

- Highway classification
- Location (Suburban, urban, urban core, rural, or rural town)
- Design year forecast traffic volumes (for the initial year of construction of the project plus 20 years)
- Traffic composition
- Design vehicle
- Design speed
- The number of intersection legs
- Driver expectancy
- Pedestrian/bicycle access
- Right-of-way
- Access control
- Terrain
- Environmental concerns
- Economics

The **Project Development Division (PDD)** submits recommendations for the construction of a grade separation or an interchange. **Traffic Engineering**, the **District Engineer (DE)**, the **Roadway Design Engineer** and/or the **Assistant Design Engineer (ADE)** may also make a recommendation. When a new interchange for an Interstate is recommended, an Interchange Justification Report (IJR) may be required and **Federal Highway Administration (FHWA)** approval is necessary. An Interchange Modification Report (IMR) may be required, with **FHWA** approval, when changes are proposed to an existing access to the Interstate. These reports will focus on the technical and operational feasibility of the proposed access; the social, economic, and environmental impacts will be addressed in the NEPA review (reconstruction or major modifications to existing interchanges that do not involve adding roadway capacity may be eligible for classification as a CE). Guidance for **FHWA** procedures/requirements for Interstate access are in the **FHWA Policy on Access to the Interstate** (May 22, 2017) (<https://www.fhwa.dot.gov/design/interstate/170522.cfm>).

## **2.A FHWA Design Discipline Support Tool for Interchanges**

The FHWA Design Discipline Support Tool contains additional discussion on and a convenient prompt-list for the elements of interchange design for New and Reconstructed projects. This document may be found at (<https://www.fhwa.dot.gov/modiv/programs/intersta/idp.cfm>).

## **2.B General Interchange Design Considerations**

Detailed discussion of the following general considerations for the design of interchanges are in Chapter 10, Section 10.9.5, of the *Green Book* (Ref. 5.2).

- Determination of Interchange Configuration
- Approaches to the Structure
- Sight Distance
- Interchange Spacing
- Uniformity of Interchange Patterns
- Route Continuity
- Overlapping Routes
- Signing and Marking
- Basic Number of Lanes
- Coordination of Lane Balance and Basic Number of Lanes
- Auxiliary Lanes
- Lane Reductions
- Weaving Sections
- Collector-Distributor Roads
- Two-Exit versus Single Exit Interchange Design
- Wrong-Way Entry

Additional considerations to be aware of include:

- Cost: Interchanges are the most expensive type of roadway intersection.
- Constructability: Phasing and traffic accommodation during construction must be addressed. Closing an entrance to the Interstate during construction is allowable but exits from the Interstate should be kept open. The design speed for phasing is 10 mph below the posted speed limit.
- Drainage: Considerations include bridge deck drainage, erosion control of slopes, drainage of the low point of the roadway under an overpass, and erosion control during construction.
- Crossroad Intersection Sight Distance: Sight distance requirements for at-grade intersections apply at the ramp/crossroad intersections of interchanges. An added sight distance element at interchange intersections involves the bridge structure supporting the secondary facility over or under the major highway.
- ROW constraints
- Environmental impacts

## 2.C Interchange Warrants

An interchange is an effective, but expensive, means of reducing intersection capacity problems. Warrants for interchange use at individual locations will vary due to such factors as site condition, design year traffic volume, highway classification, and interchange layout. Six warrants in particular should be considered when determining the applicability of a grade separation or an interchange for a given location:

1. Design designation: full access control will necessitate the use of grade separations and/or interchanges. All Interstate access points will be interchanges.
2. Reduction of bottlenecks or spot congestion: the inability to provide intersection capacity may make the construction of an interchange a viable option.
3. Reduction of crash frequency and severity: intersections with high accident rates may warrant interchanges.
4. Site topography: topographic conditions may preclude cost effective provision of at-grade intersections.
5. Road-user benefits: an interchange may be advisable due to the attendant costs of traffic delays (e.g. user delay, fuel consumption, engine wear).
6. Traffic volumes: volumes too great for an at-grade intersection to handle efficiently may warrant an interchange.

These warrants are expanded on in Chapter 10, Section 10.2, of the *Green Book* (Ref. 5.2).

## 2.D Adaptability of Highway Grade Separations and Interchanges

The three basic types of intersections are at-grade intersections, grade separations without ramps, and interchanges. Each type is a feasible solution for a range of situations but there is no demarcation line denoting when one type becomes preferable over another. Some overlapping exists between these ranges, the ultimate design may be a compromise based on consideration of the following factors:

- Traffic and operation (See Chapter 10, Section 10.3.1, of the *Green Book*, Ref. 5.2)
- Site conditions (See Chapter 10, Section 10.3.2, of the *Green Book*, Ref. 5.2)
- Type of highway and intersecting facility (See Chapter 10, Section 10.3.3, of the *Green Book*, Ref. 5.2)
- Access separations and control on the crossroad at interchanges (See Chapter 10, Section 10.4, of the *Green Book*, Ref. 5.2)
- Safety (See Chapter 10, Section 10.5, of the *Green Book*, Ref. 5.2)
- Stage Development (See Chapter 10, Section 10.6, of the *Green Book*, Ref. 5.2)
- Economic factors (See Chapter 10, Section 10.7, of the *Green Book*, Ref. 5.2)

## **2.E      Grade Separation Structures**

See Chapter 10, Section 10.8 of the *Green Book* (Ref. 5.2) for a detailed discussion.

The **Bridge Division (Bridge)** is responsible for the design of grade separation structures; the designer will coordinate with **Bridge** on grade separation/interchange design and on railroad overpass designs. For projects involving the construction of an overpass or of a viaduct over a railroad line, the **Highway Liaison Manager** in the **Rail Unit** in the **Local Assistance Division** and the railroad company will need to be involved in discussions early in the design process. Minimum bridge widths are given in the *MDS* (Ref. 5.5). See Chapter Ten: Miscellaneous Design Issues, Section 1, “Railroads”, and Section 2, “Bridge Structures”, of this manual for additional information.

### **2.E.1      Underpass Roadways**

See Chapter 10, Section 10.8.4, of the *Green Book* (Ref. 5.2).

#### **2.E.1.a      Roadway Cross-Section**

The cross-section through an underpass should be the same as the approach roadway cross-section, including the clear zone or roadside barriers. Future widening of the roadway should be considered if significant traffic volume increases are anticipated in the near future (provide sufficient additional width for an additional lane in each direction to be added later).

#### **2.E.1.b      Underpass Sight Distance**

The designer should verify that when sag vertical curves are used on underpasses the overhead structure does not obstruct driver visibility. Equations 3-53 and 3-54 of the *Green Book* (Ref. 5.2) should be used to calculate the appropriate overhead clearance to provide stopping sight distance. See Chapter Three: Roadway Alignment, Section 3.D, “Sag Vertical Curves”, of this manual for additional information.

#### **2.E.1.c      Vertical Clearance**

The allowable vertical clearances for overhead structures are in the *MDS* (Ref. 5.5). See Chapter Ten: Miscellaneous Design Issues, Section 2.E, “Vertical Clearances”, of this manual for additional information. An additional six-inch allowance should be included in the minimum vertical clearance for future resurfacing of the underpass.

### **2.E.2      Overpass Roadways**

See Chapter 10, Section 10.8.5, of the *Green Book* (Ref. 5.2).

#### **2.E.2.a      Roadway Cross-Section**

It is desirable to carry the full width of the approach roadway across the overpass.



### 2.E.3 Local Roads Crossing Freeways and Expressways

When **NDOT** is constructing or upgrading an off-system crossroad over or under a freeway or expressway as part of a New or Reconstructed project, **NDOT** will fund the crossroad construction to match the existing section. Maintenance of the structure and road over the mainline is the responsibility of the **State**. The designer will coordinate all necessary agreements with the **Agreements and Consultant Services Section** of **PDD** as early in the project as possible. For additional information, see *NDOT Operating Instructions 45-5, "Agreements"* and *60-12, "Cost Sharing for Local Roads Crossing Freeways and Expressways"* in Appendix B, "Selected *NDOT Operating Instructions*" of this manual.

## 2.F Interchange Configurations

Interchange configurations generally take one of three types: three-leg designs, four-leg designs, and special interchange designs involving two or more structures. The type and configuration of an interchange is site dependent, based on such factors as the number of legs, design year forecast traffic, traffic composition (through volumes and turning movements), truck traffic, topography, right-of-way, environmental concerns, etc. Chapter 10, Section 10.9, of the *Green Book* (Ref. 5.2) discusses interchange types and configuration in detail. EXHIBIT 5.6 shows some commonly used interchange configurations.

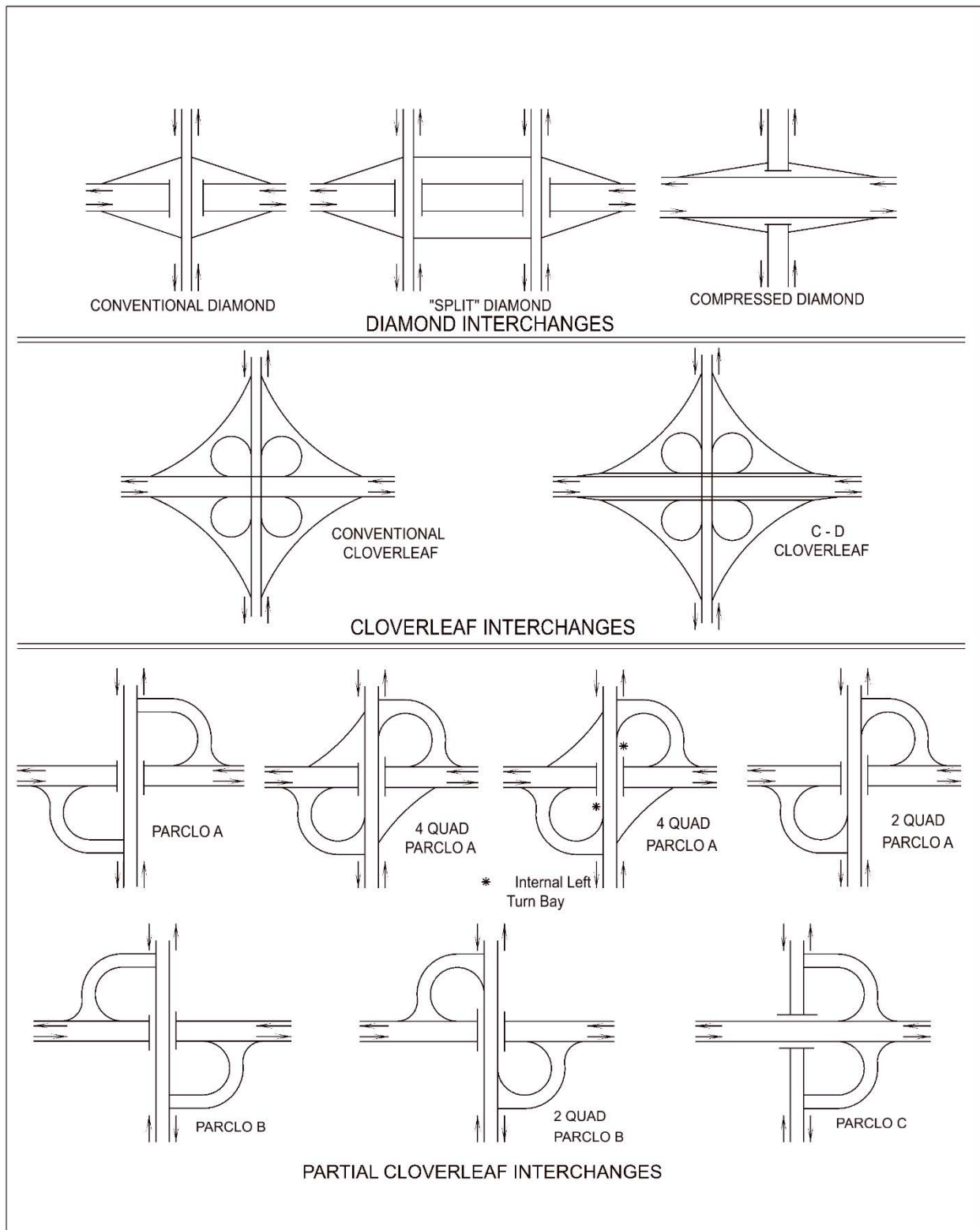
Interchange types are many, varied, and evolving. One helpful reference, in addition to the *Green Book* (Ref. 5.2), is the **FHWA** publication Alternative Intersections/Interchanges: Informational Report (AIR) (<https://www.fhwa.dot.gov/publications/research/safety/09060/>).

### 2.F.1 Single Point Urban Interchange

The Single Point Urban Interchange (SPUI) (EXHIBIT 5.7) is a variation of the Compressed Diamond Interchange (See EXHIBIT 5.6), requiring less right-of-way than the Diamond Interchange. The turning movements of the major road ramps and the movements of the minor road occur in the central area of the interchange, at one signalized intersection. SPUIs increase highway capacity and accommodate more vehicles than conventional diamond interchanges.

### 2.F.2 Diverging Diamond Interchange

The Diverging Diamond Interchange (DDI) (EXHIBIT 5.8) shifts the left-turning traffic to the opposite side of the roadway at two signalized intersections. This reduces the conflict between left-turning vehicles and on-coming traffic common to conventional interchanges, enhancing the safety and operational capacity of the interchange. For additional information see NCHRP Research Report 959 "Diverging Diamond Interchange, Informational Guide, Second Edition" (2021) (<https://www.trb.org/Main/Blurbs/181562.aspx>).



**Exhibit 5.6 Common Interchange Configurations**

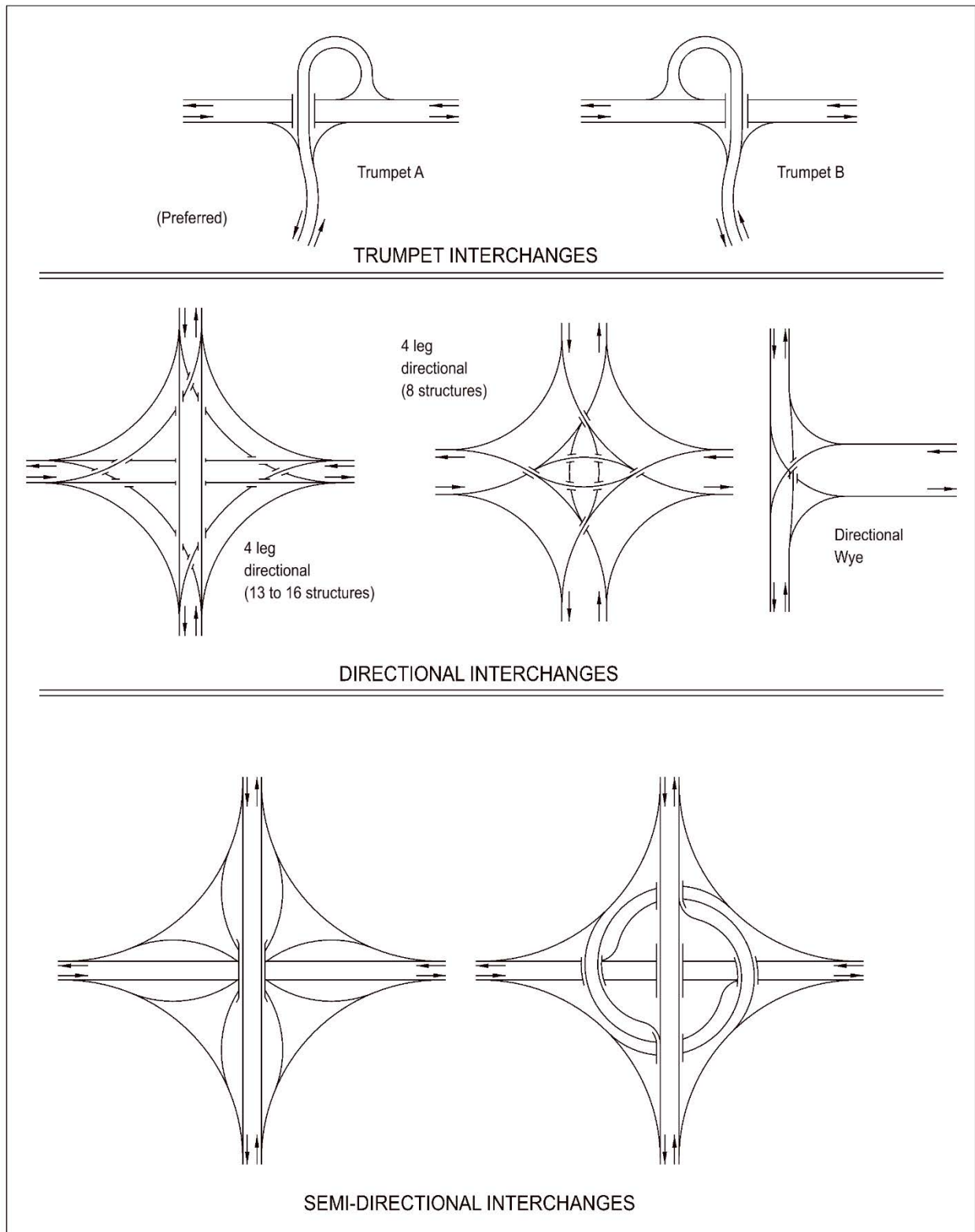
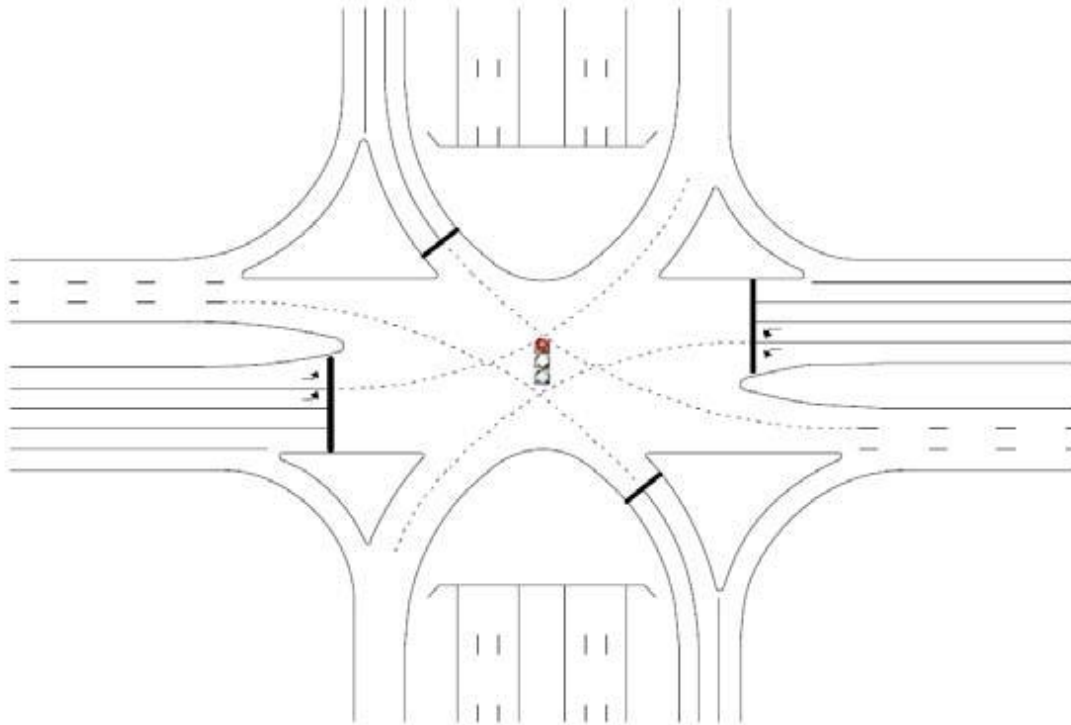
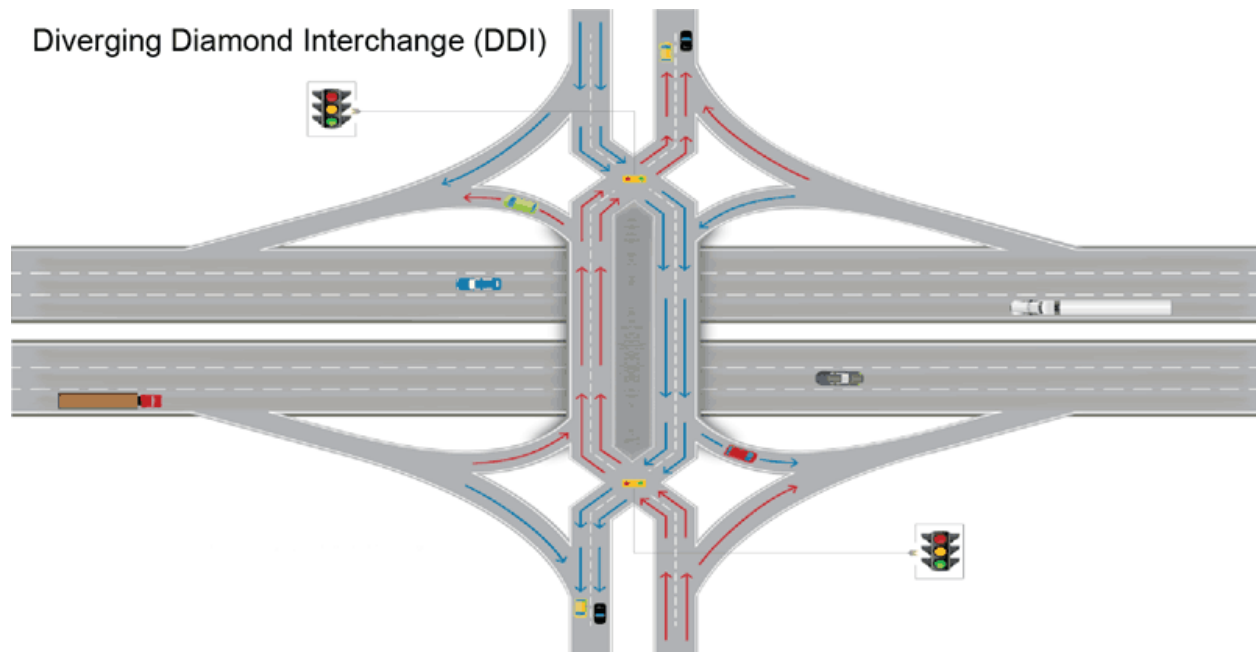


Exhibit 5.6 Common Interchange Configurations



**Exhibit 5.7 Single Point Urban Interchange (SPUI)**  
Source: Transportation Research Board



**Exhibit 5.8 Diverging Diamond Interchange (DDI)**  
Source: Wisconsin DOT

## **2.G Pedestrian and Bicycle Accommodation at Interchanges**

While the **State of Nebraska** does not allow pedestrians and bicycles on the Interstate or freeways (See Section 1.K of this chapter), the accommodation of pedestrians and bicyclists should be considered in the selection of an interchange. Pedestrian/bicycle routes should be as direct as possible, and if practicable should be separate from the roadway. Crosswalk locations should be visible to the drivers and the crosswalks should be as short as possible with pedestrian refuge islands provided as necessary. For additional information, see Chapter 10, Section 10.9.7.2, of the *Green Book* (Ref. 5.2) and NDOT Operating Instruction 60-10, “ADA Accessibility Requirements in Transportation Projects” in Appendix B, “Selected NDOT Operating Instructions”, of this manual.

## **2.H Interchange Spacing**

Interchange spacing is influenced by such variables as roadway type, roadway location, interchange design, ramp design, etc. A Policy on Design Standards – Interstate System, May 2016 (Ref. 5.1) states that the minimum interchange spacing for the Interstate should be one mile in urban areas and three miles in rural areas. Spacing of less than one mile may be developed in urban areas by grade-separated ramps or by collector-distributor roads (a design exception from **FHWA** is required). For **NDOT** spacing guidelines on other access controlled highways, see Chapter Fifteen: Right-of-Way, EXHIBIT 15.3, of this manual. For additional information on interchange spacing, see Chapter 10, Section 10.9.5.3, of the *Green Book* (Ref. 5.2).

## **2.I Interchange Lighting**

Warrants for interchange lighting on Interstates will be as outlined in the **AASHTO** publication Roadway Lighting Design Guide (Ref. 5.7). The operational and maintenance costs of interchange lighting that falls within the corporate limits of a **City/Village** will be the sole responsibility of the **City** or **Village**. See Chapter Ten: Miscellaneous Design Issues, Section 13, “Roadway Lighting” and NDOT Operating Instruction 60-11, “Municipal Cost Sharing” in Appendix B, “Selected NDOT Operating Instructions”, of this manual for additional information.

## **3. RAMPS**

See Chapter 10, Section 10.9.6 of the *Green Book* (Ref. 5.2) for a detailed discussion of ramp design.

Additional guidance for ramp design, beyond that found in the *Green Book* (Ref. 5.2), is available in the following **National Cooperative Highway Research Program (NCHRP)** publications:

- NCHRP Report 687 “Guidelines for Ramp and Interchange Spacing” (April 2011) (<https://www.trb.org/main/blurbs/165126.aspx>).
- NCHRP Report 730 “Design Guidance for Freeway Mainline Ramp Terminals” (October 2012) (<https://www.trb.org/main/blurbs/167516.aspx>).
- NCHRP Web-Only Document 227 “Design of Interchange Loop Ramps and Pavement/Shoulder Cross-Slope Breaks” (February 2017) (<https://www.trb.org/Publications/Blurbs/175608.aspx>).

### 3.A Ramp Types

Ramps are turning roadways connecting the legs at an interchange and are also used at rest areas and weigh stations. Figure 10-60 of Chapter 10 of the *Green Book* (Ref. 5.2) illustrates the general types of ramps.

### 3.B General Ramp Design Considerations

As expanded upon in Section 10.9.6.2 of the *Green Book* (Ref. 5.2), the general considerations in ramp design include the following:

1. Design Speed. Table 10-1 of the *Green Book* (Ref. 5.2) presents guide values for ramp design speed related to highway design speed.
2. Portion of ramp to which design speed is applicable. Design speeds for ramps may be divided into three segments: speeds at each terminal and speed through the connecting roadway between the terminals.
3. Ramps for right turns.
4. Loop ramps. The **NDOT** desirable loop radius is 250 feet; the minimum loop radius is 100 feet
5. Two-Lane Ramps. See [EXHIBIT 5.10](#).
6. Semi-Direct Connections (a ramp where a left-turning vehicle first exits to the right).
7. Direct Connections (a ramp that does not deviate from the intended direction of travel).
8. Different Design Speeds on Intersecting Highways.
9. At-Grade Terminals.
10. Ramp Curvature. **NDOT** uses spiral transitions on ramp curves, See Section 3.C of this chapter.
11. Sight Distance.
12. Grade and Profile Design. Also discussed in Chapter Three: [Roadway Alignment](#), Section 3.A, “Grades”, of this manual.
13. Vertical Curves. Also discussed in Chapter Three: [Roadway Alignment](#), Section 3.B, “Vertical Curves”, of this manual.
14. Superelevation and Cross-Slope. Superelevation is discussed in Chapter Three: [Roadway Alignment](#), Section 2.C, “Superelevation”, of this manual. [EXHIBITS 5.9 & 5.10](#) shows the typical cross-sections for one-lane and two-lane interchange ramps. Superelevation and cross-slope are also discussed in Chapter 3, Section 3.3, of the *Green Book* (Ref. 5.2). The **NDOT** maximum allowable rollover rate (difference in cross-slope) is 7% between the ramp travel lane and the shoulder and 5% between lanes.
15. Gores. Gore generally refers to the area between a through roadway and an exit ramp (See the *Green Book* (Ref. 5.2), Figures 10-63 and 10-64). The maximum rollover rate in the gore area is 5%.
16. Ramp Traveled-Way Widths. See [EXHIBITS 5.9 & 5.10](#).
17. Ramp Shoulder Widths and Lateral Offset. See [EXHIBITS 5.9 & 5.10](#).
18. Shoulders and Curbs.
19. Ramp Terminals.
20. Drainage.

The following items are operational in nature and will be designed taking recommendations from **Traffic Engineering** into consideration.

1. Left-Side Entrances and Exits. Left-hand entrances and exits should only be used at weigh stations on expressways.
2. Ramp Terminal Location and Sight Distance.
3. Ramp Terminal Design.
4. Traffic Control. Traffic control will be designed by **Traffic Engineering**, see Chapter Fourteen: Traffic, of this manual.
5. Distance Between a Free-Flow Ramp Terminal and a Structure.
6. Distance Between Successive Ramp Terminals. Figure 10-71 of the *Green Book* (Ref. 5.2) presents the minimum recommended ramp terminal spacing.
7. Speed-Change Lanes. Auxiliary lanes are discussed in Chapter 10, Section 10.9.5.10 of the *Green Book* (Ref. 5.2).
8. Single-Lane Free-Flow Ramp Terminals.
  - Taper-Type Entrances. See Figure 10-72 of the *Green Book* (Ref. 5.2).
  - Parallel-Type Entrances. See Figure 10-72 of the *Green Book* (Ref. 5.2).
  - Taper-Type Exits. See Figure 10-73 of the *Green Book* (Ref. 5.2).
  - Parallel-Type Exits. See Figure 10-73 of the *Green Book* (Ref. 5.2).
  - Free-Flow Ramp Terminals on Curves. See Figures 10-74 and 10-75 of the *Green Book* (Ref. 5.2).
9. Multi-Lane Free-Flow Ramp Terminals.
  - Two-Lane Entrances. See Figure 10-76 of the *Green Book* (Ref. 5.2).
  - Two-Lane Exits. See Figure 10-77 of the *Green Book* (Ref. 5.2).
  - Two-Lane Terminals on Curved Alignments.
  - Major Forks and Branch Connections. See Figures 10-78 and 10-79 of the *Green Book* (Ref. 5.2).

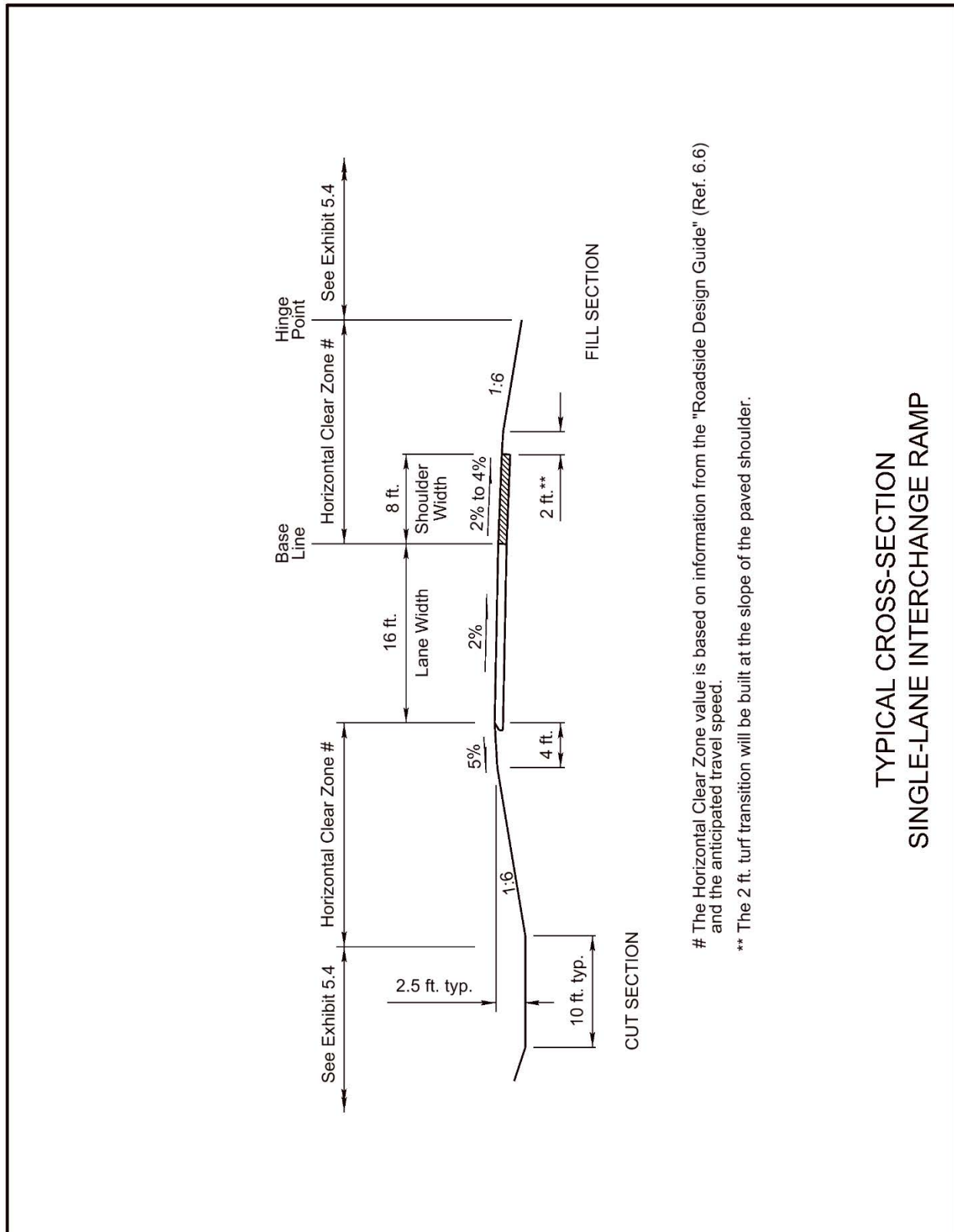
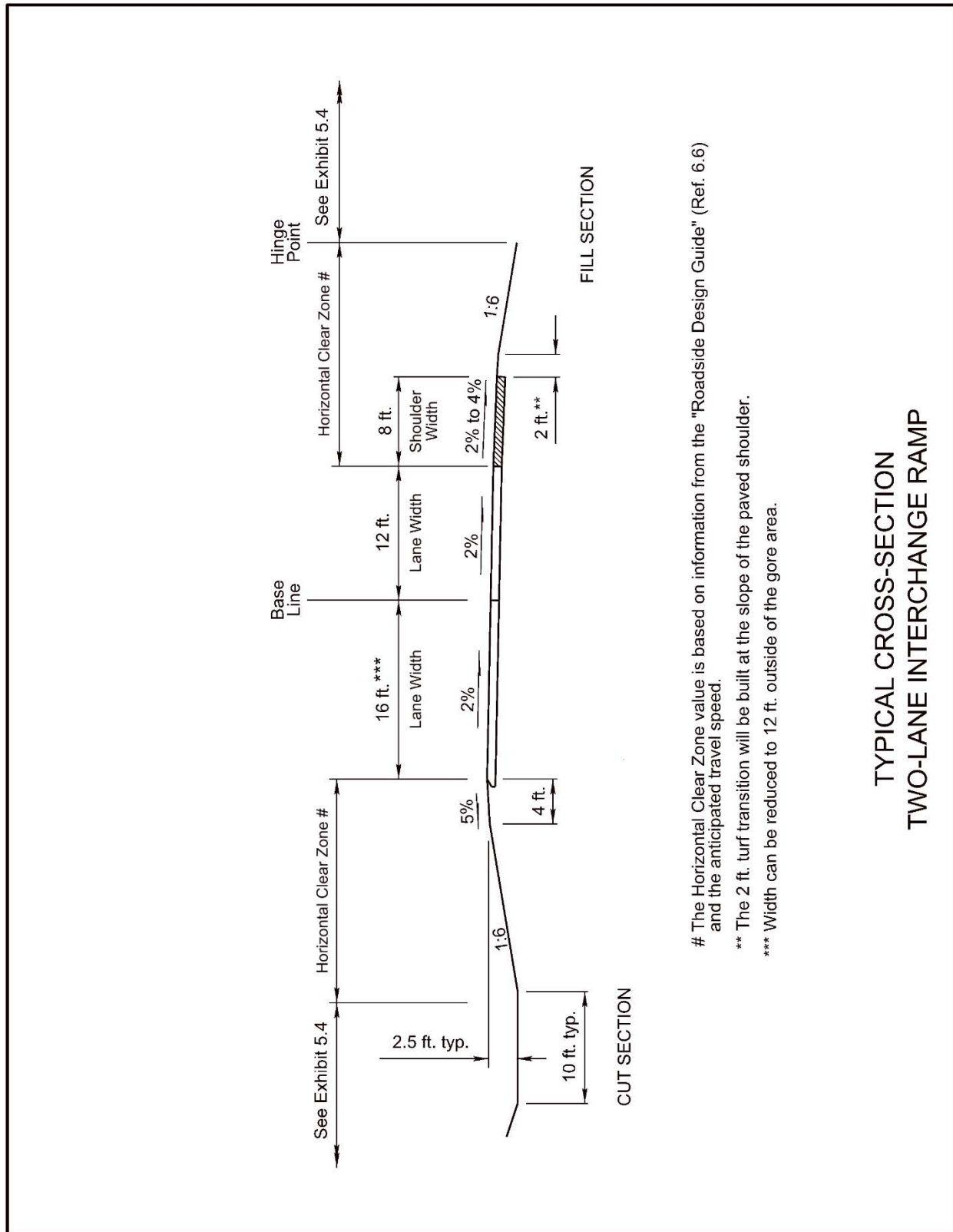


Exhibit 5.9 Typical Section of an Interchange Ramp  
 One-Lane





# The Horizontal Clear Zone value is based on information from the "Roadside Design Guide" (Ref. 6.6) and the anticipated travel speed.

\*\* The 2 ft. turf transition will be built at the slope of the paved shoulder.

\*\*\* Width can be reduced to 12 ft. outside of the gore area.

**Exhibit 5.10 Typical Section of an Interchange Ramp Two-Lane**

### 3.C Spiral Transition Curves

Spiral transitions are provided on ramps to ease the change from a straight section of roadway to a curved section, gradually changing from an infinite radius at the tangent end to the curve radius at the circular curve end. Spiral transitions gradually increase and decrease centrifugal force as vehicles enter and exit circular curves, providing the driver with a natural path to follow and a more comfortable ride.

While **NDOT** sees only marginal benefits in the design of spiraled transition curves for new roadway alignments, spiral transition curves are preferred on Interstate ramps due to the higher percentage of truck traffic.

EXHIBITS 5.11 & 5.12 shows spiral curve information for the spiral in, spiral out of equal length condition. For additional information, see "Spiral Curve Transitions" in Chapter 3, Section 3.3.8.3, of the *Green Book* (Ref.5.2).

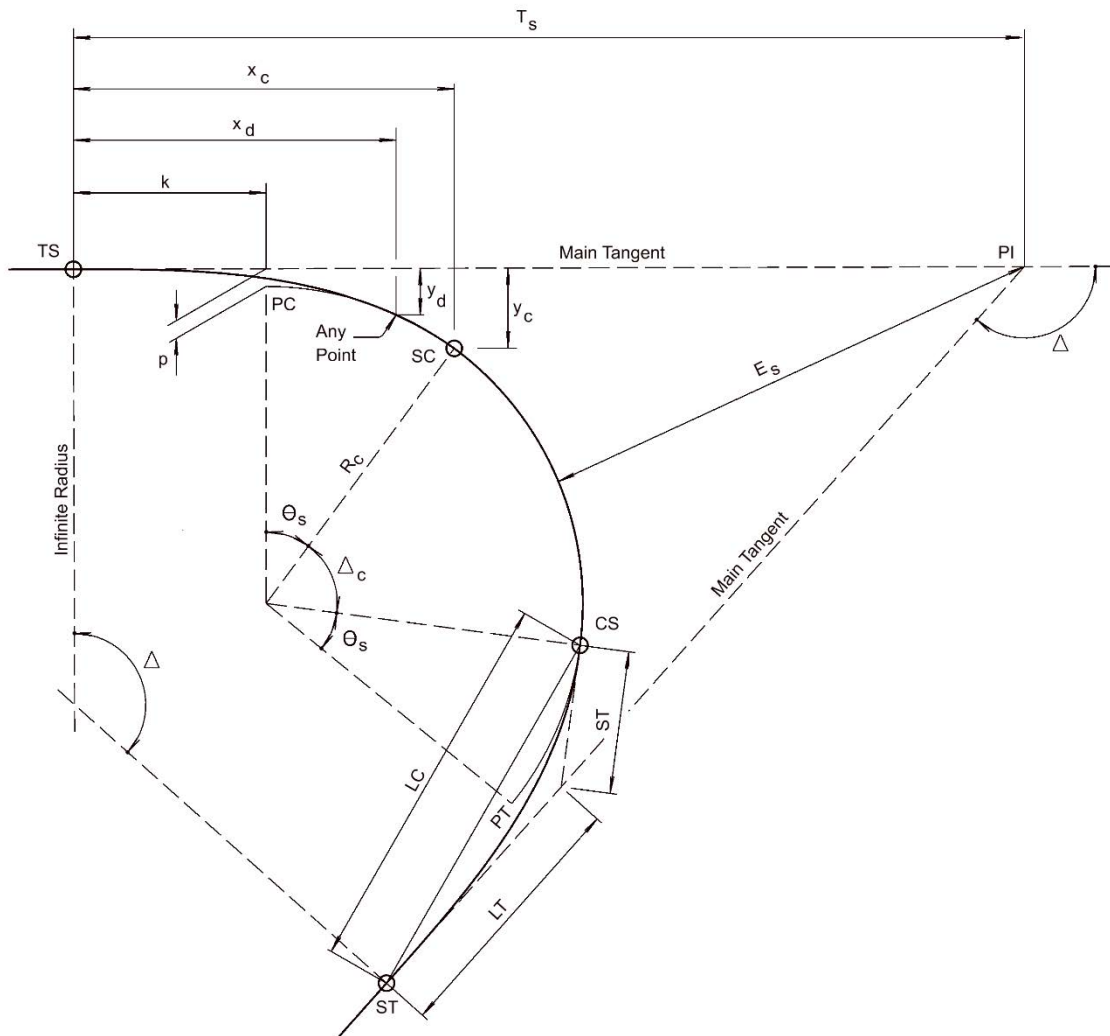


Exhibit 5.11 Components of a Spiral Curve, Spiral In, Spiral Out of Equal Length

**Stations:**

PI Sta. = point of intersection  
 TS Sta. = tangent to spiral  
 SC Sta. = spiral to circular curve  
 CS Sta. = circular curve to spiral  
 ST Sta. = spiral to tangent

**Station Formulas:**

TS Sta. = PI Sta. - T  
 SC Sta. = TS Sta. +  $L_s$   
 CS Sta. = SC Sta. =  $L_c$   
 ST Sta. = CS Sta. +  $L_s$

**Terminology:**

$\Delta$  = total deflection angle  
 $\theta_s$  = spiral deflection angle  
 $\Delta_c$  = circular curve deflection angle  
 $D_c$  = degree of circular curve  
 $L_s$  = length of spiral curve  
 $L_c$  = length of circular curve  
 $R_c$  = radius of circular curve  
 $T_s$  = total tangent length  
 LT = long tangent of spiral curve  
 ST = short tangent of spiral curve  
 LC = straight chord line distance TS to SC/CS to ST  
 $x_c, y_c$  = coordinates of SC point referred to the main tangent as the X-axis and the TS as origin  
 $x_d, y_d$  = coordinates of any point on spiral referred to the main tangent as the X-axis and the TS as origin at a distance (d) from the TS  
 p = offset distance from the main tangent to the PC of the circular curve  
 k = distance from the TS to a point on the main tangent opposite the PC of the circular curve  
 $E_s$  = external distance from circular curve to point of intersection for total curve  
 d = distance along spiral from TS

**Formulas ( $\theta_s$  in radians):**

$\theta_s$  =  $L_s/(2R_c)$   
 $y_c$  =  $L_s(\theta_s/3 - \theta_s^3/42)$   
 $x_c$  =  $L_s(1 - \theta_s^2/10)$   
 $p$  =  $y_c - R_c(1 - \cos \theta_s)$   
 $k$  =  $x_c - (R_c \sin \theta_s)$   
 $x_d$  =  $d - (d\theta_d^2)/10$   
 $y_d$  =  $(d\theta_d)/3$

**Formulas ( $\theta_s, \Delta, \Delta_c$  in degrees):**

(See Appendix G: "Degree of Curvature")

$T_s$  =  $(R_c + P) (\tan \Delta/2) + k$   
 $E_s$  =  $(R_c + P) (\sec \Delta/2 - 1) + p$   
 $\theta_s$  =  $(L_s D_c)/200$   
 $\Delta_c$  =  $\Delta - 2\theta_s$   
 $L_c$  =  $100(\Delta_c/D_c)$   
 $R_c$  =  $5729.578/D_c$   
 LT =  $x_c - (y_c \cot \theta_s)$   
 ST =  $y_c \csc \theta_s$

**Exhibit 5.12 Spiral Curve Information, Spiral In, Spiral Out of Equal Length**

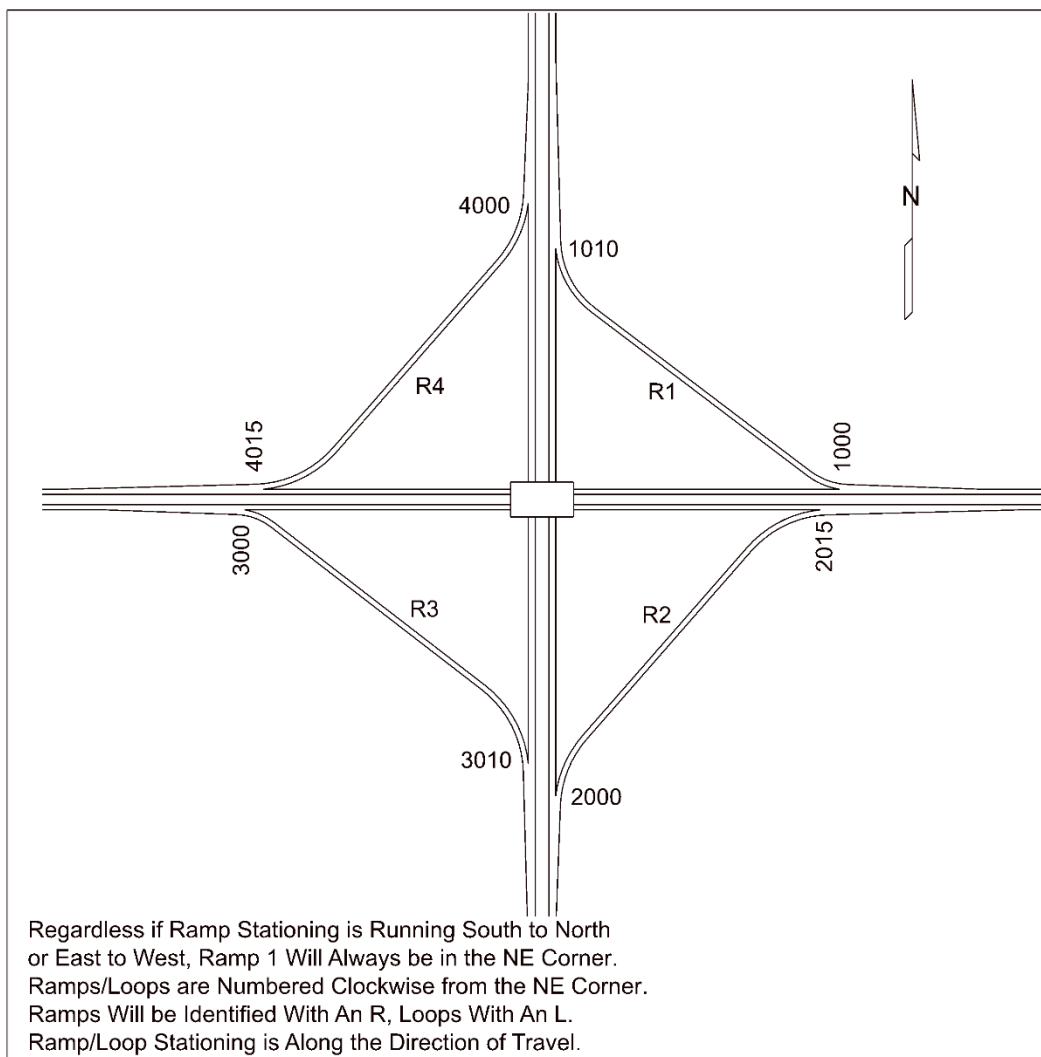
### 3.D Additional NDOT Ramp Considerations

**Baseline:** The baseline on ramps and loops is usually located at the right edge of the 16 foot travel lane (See [EXHIBIT 5.9](#)).

**Earthwork:** When earthwork is calculated, ramps should have separate roadways and shear lines (See Chapter Seven: [Earthwork](#), Section 3.E, “Shear Lines”).

**Identification:** A ramp is identified on the plans with an R and a loop is identified with an L. They are numbered clockwise from the NE quadrant. Unique letter and roadway stationing shall be used for each element (See [EXHIBIT 5.13](#)).

**Stationing:** Stationing is along the direction of travel (See [EXHIBIT 5.13](#)).



**Exhibit 5.13 Stationing for Ramps and Loops**

#### 4. REFERENCES

- 5.1 American Association of State Highway and Transportation Officials, A Policy on Design Standards – Interstate System, Washington, DC, May 5.5 2016.
- 5.2 American Association of State Highway and Transportation Officials, A Policy on the Geometric Design of Highways and Streets (the *Green Book*), Washington, DC, 2018.
- 5.3 Transportation Research Board, National Research Council, Highway Capacity Manual, Sixth Edition, Washington, DC, 2017.
- 5.4 U.S. Department of Transportation, Federal Highway Administration, Manual on Uniform Traffic Control Devices for Streets and Highways (MUTCD), Washington, DC, 2009. (<https://dot.nebraska.gov/business-center/contractor/mutcd/>)
- 5.5 Board of Public Roads Classifications and Standards, Nebraska Administrative Code, Title 428, Chapter Two (MDS), Current Edition. (<https://dot.nebraska.gov/media/1z1n5kmb/nac-428-rules-regs-nbcs.pdf>)
- 5.6 Nebraska Department of Transportation, Standard Specifications for Highway Construction (*Spec Book*), 2017. (<https://dot.nebraska.gov/media/g4qp4y0d/2017-specbook.pdf>)
- 5.7 American Association of State Highway and Transportation Officials, Roadway Lighting Design Guide, Washington, D.C., 2018.
- 5.8 Nebraska Department of Transportation, Drainage Design and Erosion Control Manual, Current Edition. (<https://dot.nebraska.gov/business-center/design-consultant/rd-manuals/>)



The information contained in Chapter Six: The Typical Roadway Cross-Section, dated May 2022, has been updated to reflect the January 2023 Errata. The errata addresses errors, changes in procedure, changes in NDOT department titles, changes in other Roadway Design Manual chapters and other reference material citations occurring since the latest publication of this chapter.

Chapter Six presents guidance for the design of New and Reconstructed projects; design guidance for 3R projects is provided in Chapter Seventeen.

## Chapter Six

# The Typical Roadway Cross-Section

The **Nebraska Department of Transportation (NDOT)** typical roadway cross-sections are presented in EXHIBITS 6.1 THROUGH 6.6 and EXHIBITS 6.8 THROUGH 6.10. Typical cross-sections for Interstates and interchange ramps are presented in Chapter Five: Interstates, Grade Separations, and Interchanges of this manual. Variations from these typical sections must be documented by the designer and submitted to the **Assistant Design Engineer (ADE)** for approval and to the **Traffic Engineering Division (Traffic Engineering)** for concurrence.

For additional information regarding roadway cross-section elements, see Chapter 4 of A Policy on Geometric Design of Highways and Streets (the *Green Book*) (Ref. 6.1).

## 1. THE TRAVELED WAY

### 1.A Travel Lane Widths

Lane width is determined by the roadway functional classification, traffic volumes, and design speed. The minimum lane widths are provided in the Nebraska Minimum Design Standards (MDS) (Ref. 6.2) (<https://dot.nebraska.gov/media/1z1n5kmb/nac-428-rules-regs-nbcs.pdf>) and in Appendix H, “AASHTO Minimum Design Guidance”, of this manual. The typical through lane width is 12 feet for rural and high-speed municipal roadways; low-speed municipal roadways are typically 11 feet in width.

### 1.B Travel Lane Cross Slopes

A crowned roadway cross-section “breaks” at the high point of the roadway, sloping to both shoulders, typically at a 2% cross slope (See EXHIBITS 6.1, 6.3 THROUGH 6.6, 6.8 AND 6.9). The high point of a non-superelevated crowned cross-section is usually located at the centerline of the roadway (for two-lane roadways) and at the centerline of the directional travel lanes (for multi-lane highways). Crowned cross-sections are preferred for two-lane roadways and for multi-lane divided roadways with depressed medians. The crowned cross-section allows for drainage to both sides of the roadway surface.

The tangent typical cross-section usually has the high point of the pavement on the inside (median) edge of the inner travel lane and slopes continuously across the travel lanes, typically at a 2% cross slope (See EXHIBIT 6.10). Tangent cross-sections are typically used for multi-lane divided roadways where there is a raised or flush median or where future lanes are to be added to the median (See EXHIBIT 6.7).

## 2. SHOULDERS

### 2.A Shoulder Width and Type

Shoulder width and type is based upon the roadway functional classification, traffic volumes, and design speed. Minimum shoulder widths are provided in the *MDS* (Ref. 6.2) and in Appendix H, “AASHTO Minimum Design Guidance”, of this manual.

**NDOT** prefers that an additional two feet of turf transition be provided beyond the minimum shoulder width (See EXHIBITS 6.1 THROUGH 6.6). This will maintain the minimum shoulder width after a future overlay surfacing grade raise. If this transition cannot be provided, **ADE** approval and a decision document in the project file is required. (See Chapter One: Roadway Design Standards, Section 10.C, of this manual).



### 2.A.1 Priority Commercial System Shoulder Width

The Priority Commercial System consists of the non-Interstate National Highway System routes ([https://dot.nebraska.gov/media/msgjimmqg/nat\\_hwy\\_sys.pdf](https://dot.nebraska.gov/media/msgjimmqg/nat_hwy_sys.pdf)) and the Expressway System (<https://dot.nebraska.gov/media/edshoshk/expressway-system-nebraska.pdf>). The Expressway System is also shown on the State and National Functional Classification Maps ([State & National Functional Classification Maps by County - NDOT \(nebraska.gov\)](#)), ([State & National Functional Classification Maps by City - NDOT \(nebraska.gov\)](#)).

For New and Reconstructed projects on the Priority Commercial System with an ADT of between 400 VPD and 3,999 VPD inclusive, the minimum design standard for shoulder width is six feet paved, with an additional two feet turf transition. If this policy is not followed, a decision document shall be prepared for **Assistant Design Engineer (ADE)** approval. Factors to consider are:

- System continuity
- Crash history attributable to shoulder width or to vehicles parked on the shoulders
- High heavy-truck volumes (250 Heavy Trucks per day)
- Consultation with the **District** office, including anecdotal history of problems caused by parking on shoulders
- Alternative route for Interstate traffic
- Environmental impacts
- Cost

For 3R projects on the Priority Commercial System, the minimum shoulder width shall follow the *MDS* (Ref. 6.2).

## 2.A.2 Installation of Two-Foot Surface Shoulders on Lower Volume Roads

NDOT has determined that the installation of two-foot surface shoulders with edgeline rumble stripes is an effective countermeasure for reducing roadway departure crashes on two-lane roadways. After reviewing the crash data and research literature, NDOT has determined the following to be guiding principles for the installation of two-foot shoulders and edgeline rumble stripes on the state highway system:

1. Roadway Type – Rural two-lane undivided with two-way traffic.
2. Lane Width –  $\geq 12$  feet.
3. ADT -  $\geq 1,000$  VPD (segments with ADTs from 1,000 ADT to 1,999 ADT are eligible for HSIP funding, see Chapter Twelve: Cost Estimating and Funding, Section 2.A.3).
4. Minimum Length of Segment – Three miles (historic highway segments may be added for continuity when the gap between highway segments with two-foot surface shoulders with edgeline rumble stripes is less five miles in length).
5. Other segments may be included when the segments exhibit 0.25 or greater roadway departure crashes per year per mile.
6. Connecting links on the Alternate Route System connecting the Interstate to the Parallel Alternate Route System (US-6, US-30, or US-34), regardless of the ADT. The following links are included despite having an ADT  $< 1,000$  VPD:
  - L10B – Odessa
  - L10C – Gibbon
  - L10D – Shelton
  - L40C – Alda
  - S41B – Giltner
  - S93A - Henderson

After two-foot surface shoulders and edgeline rumble stripes are installed, they will be perpetuated on subsequent projects unless their function is replaced by a similarly effective mitigation measure for roadway departure crashes. Since the installation of two-foot surface shoulders and edgeline rumble stripes may substantially modify the roadway departure crash history, the above warrants would be inaccurate.

## 2.B Shoulder Cross Slopes

The cross slope of the shoulder is based upon the functional classification of the roadway and the type of shoulder construction (paved or turf). Typically, shoulder cross slopes for rural roadways are 4% for surfaced shoulders and 6% for turf shoulders.

Surfaced median shoulders which are four feet wide and are of the same surfacing material as the traffic lanes should be at the same cross slope as the adjacent traffic lane. Wider shoulders and shoulders of a different surfacing material than the traffic lanes should slope away from the traffic lanes for drainage, typically at a 4% cross slope.

See EXHIBITS 6.1 THROUGH 6.6 for typical shoulder cross slopes.

## 2.C Beveled Edge

A beveled edge is a sloping finish to the edge of the pavement (both asphaltic concrete and Portland Cement Concrete) allowing errant vehicles to more easily re-enter the travelled way. The beveled edge will be installed on rural high-speed ( $V \geq 50$  mph) highways when:

1. The project includes two inches or greater of surfacing placement.
2. Surfaced shoulders are less than six feet in width, not including segments of erosion control curbed shoulders.
3. On the inside (median) shoulders which are less than six feet in width of Interstates, freeways, and expressways with depressed medians.
4. The roadway is not curbed.
5. At other locations identified by **Traffic Engineering** as a mitigation measure for a crash history.

The type of beveled edge to be used is based upon the project type and surfacing recommendation. For additional information, see Appendix I, "Installation of the Beveled Edge", of this manual and the **FHWA** publication Safety Edge<sub>SM</sub> Design and Construction Guide (January 5, 2012) ([https://www.fhwa.dot.gov/innovation/everydaycounts/edc-1/pdf/se\\_des\\_gde.pdf](https://www.fhwa.dot.gov/innovation/everydaycounts/edc-1/pdf/se_des_gde.pdf)).

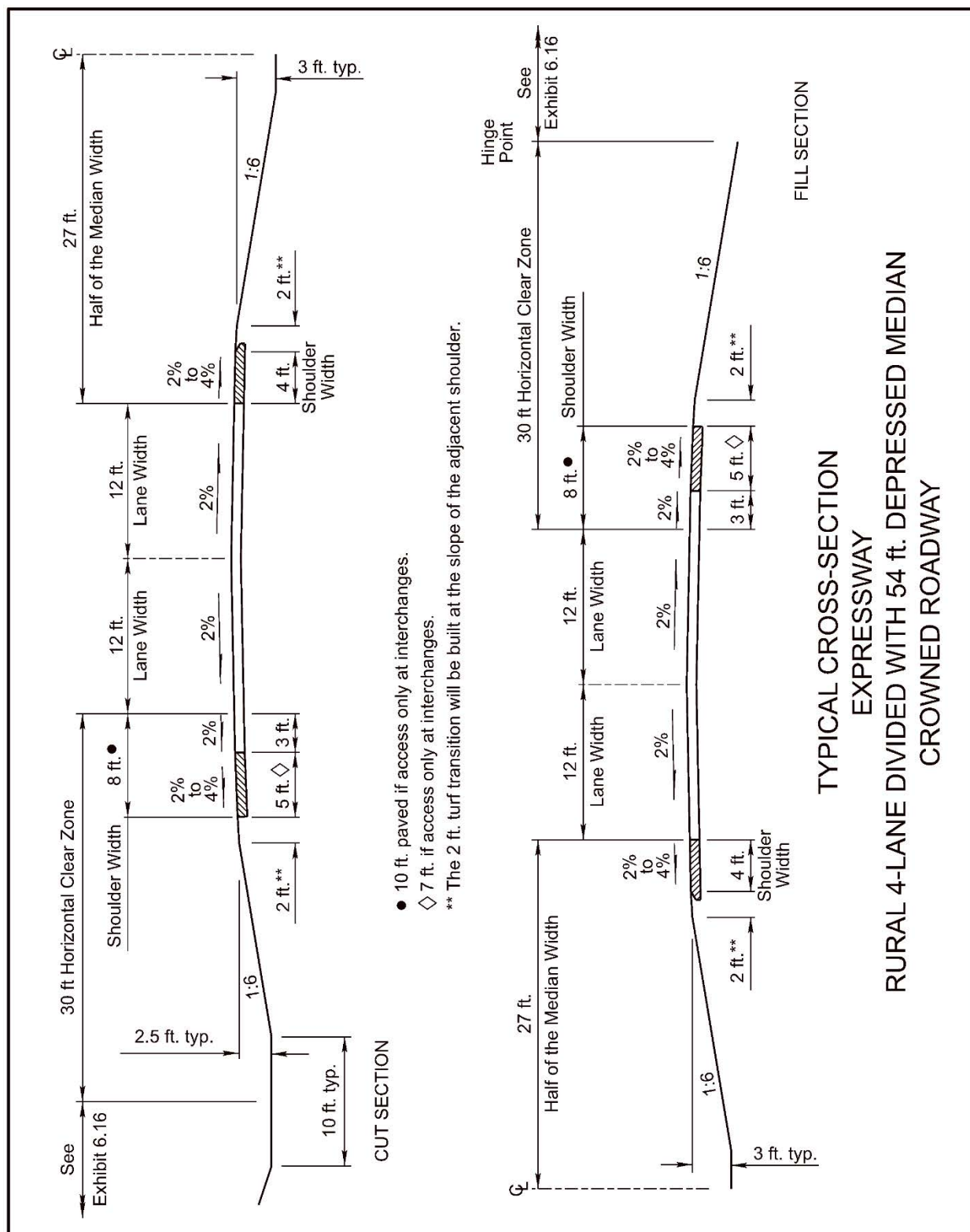


Exhibit 6.1 Typical Section - Rural Four-Lane Divided Expressway with 54 ft. Depressed Median (Crowned Roadway)

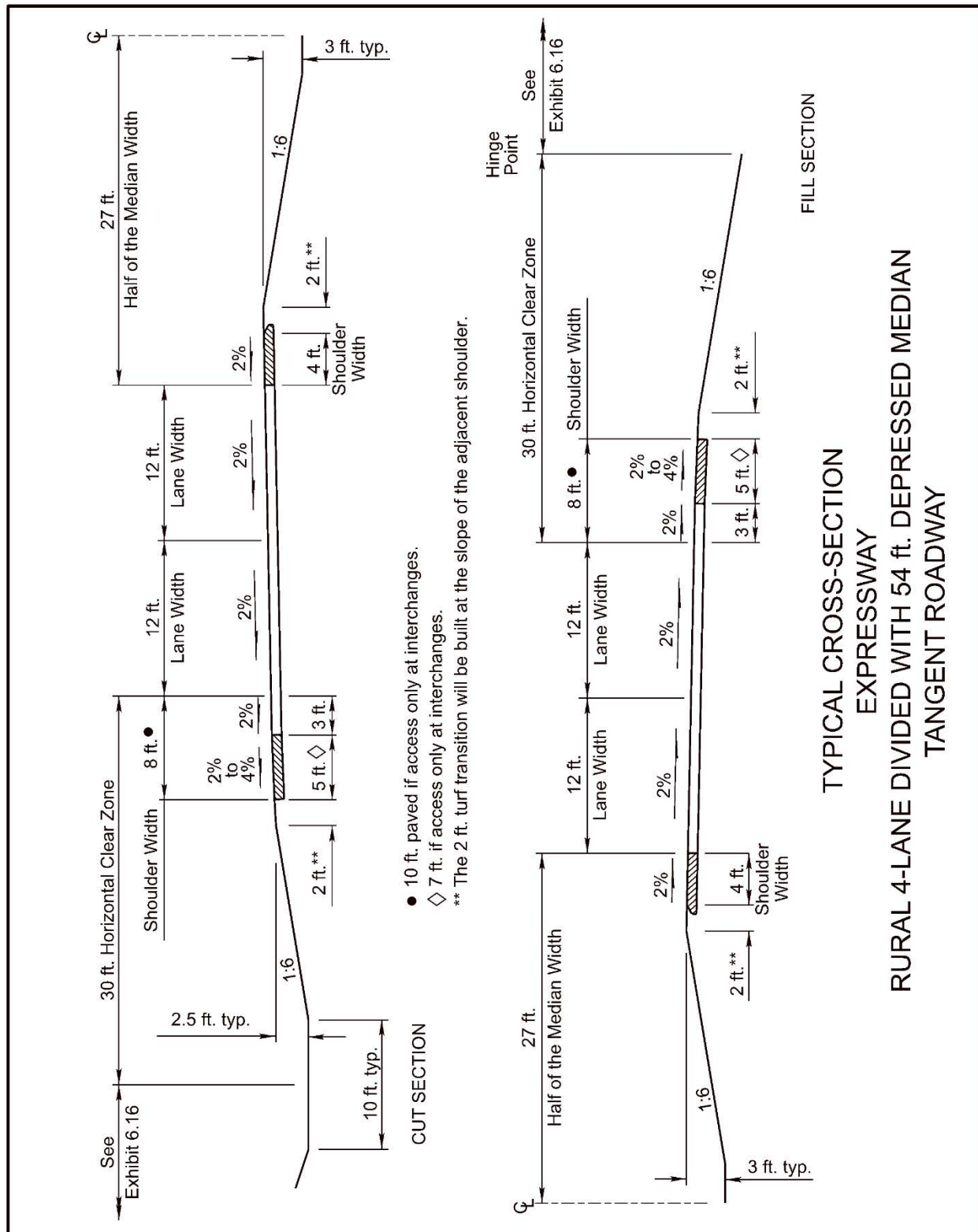


Exhibit 6.2 Typical Section - Rural Four-Lane Divided Expressway with 54 ft. Depressed Median (Tangent Roadway)

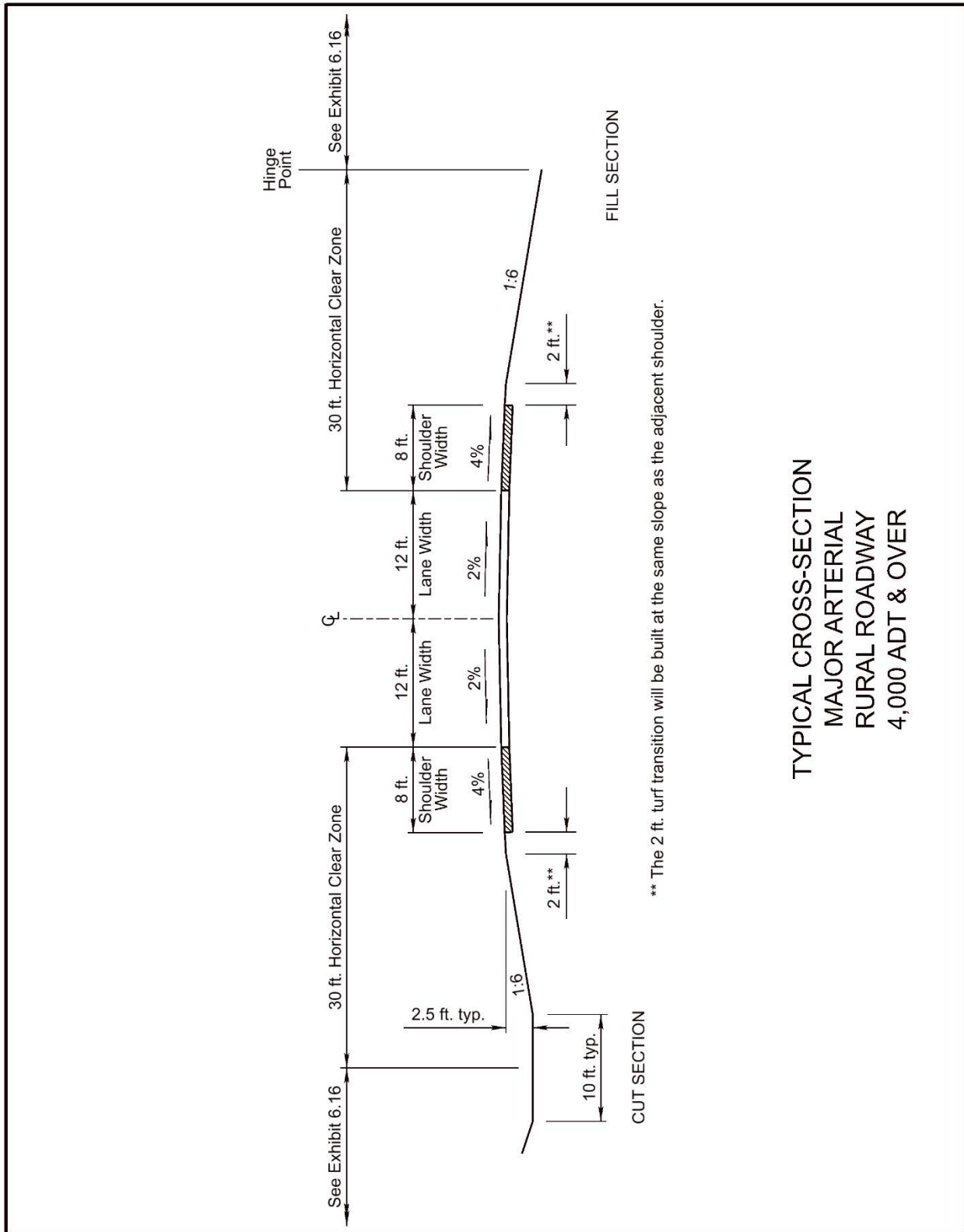


Exhibit 6.3 Typical Section - Rural Major Arterial 4,000 ADT and Over

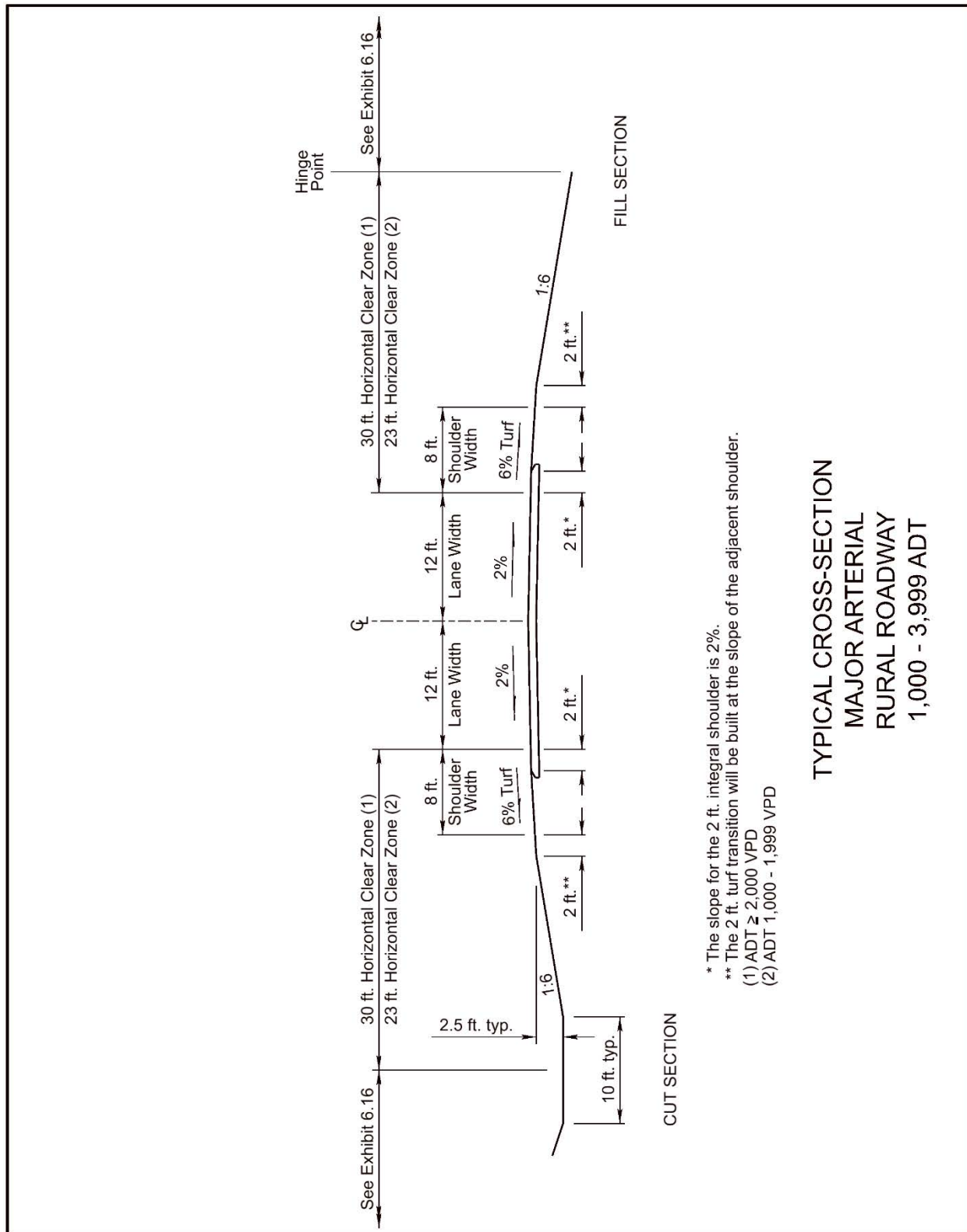


Exhibit 6.4 Typical Section - Rural Major Arterial 1,000 to 3,999 ADT

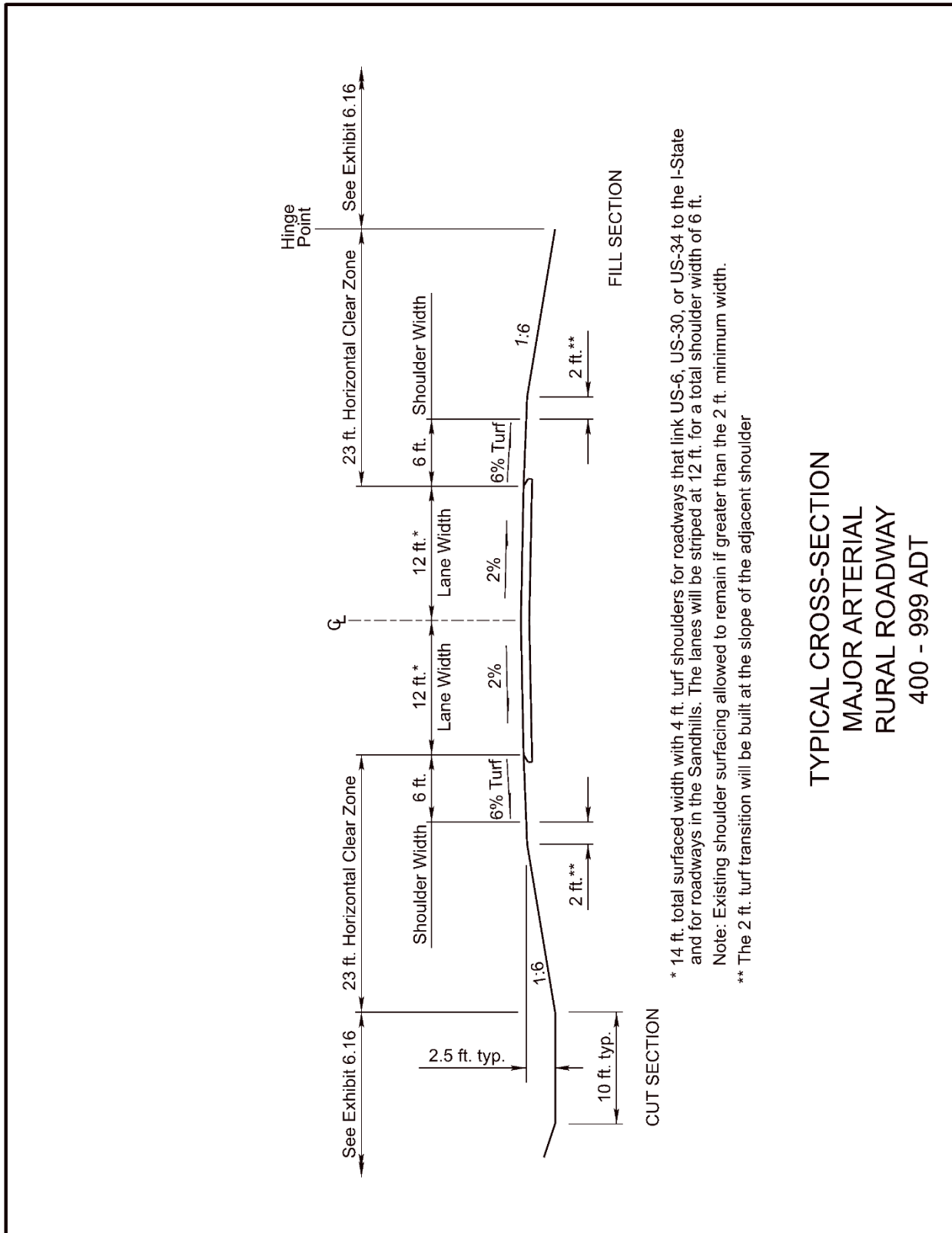
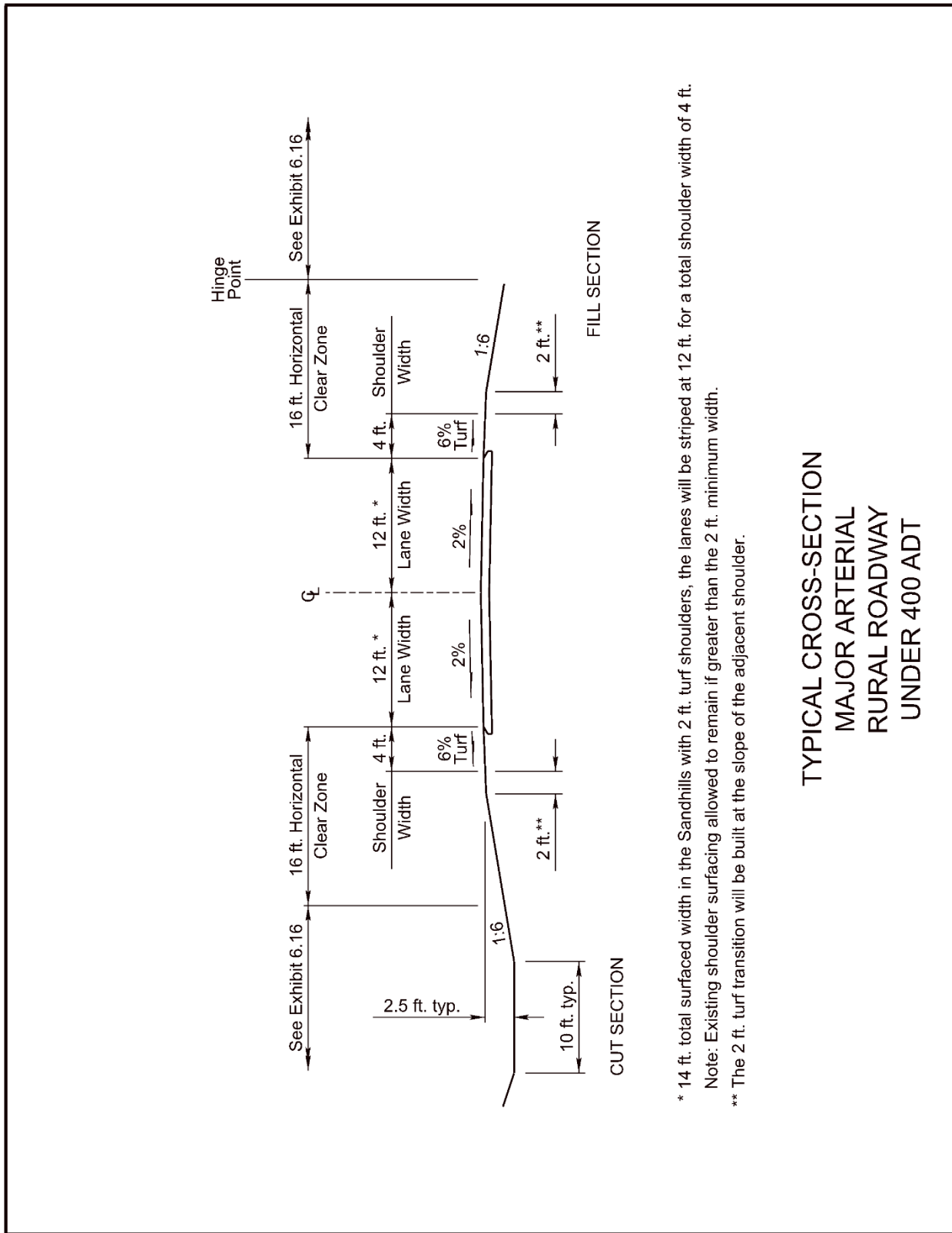


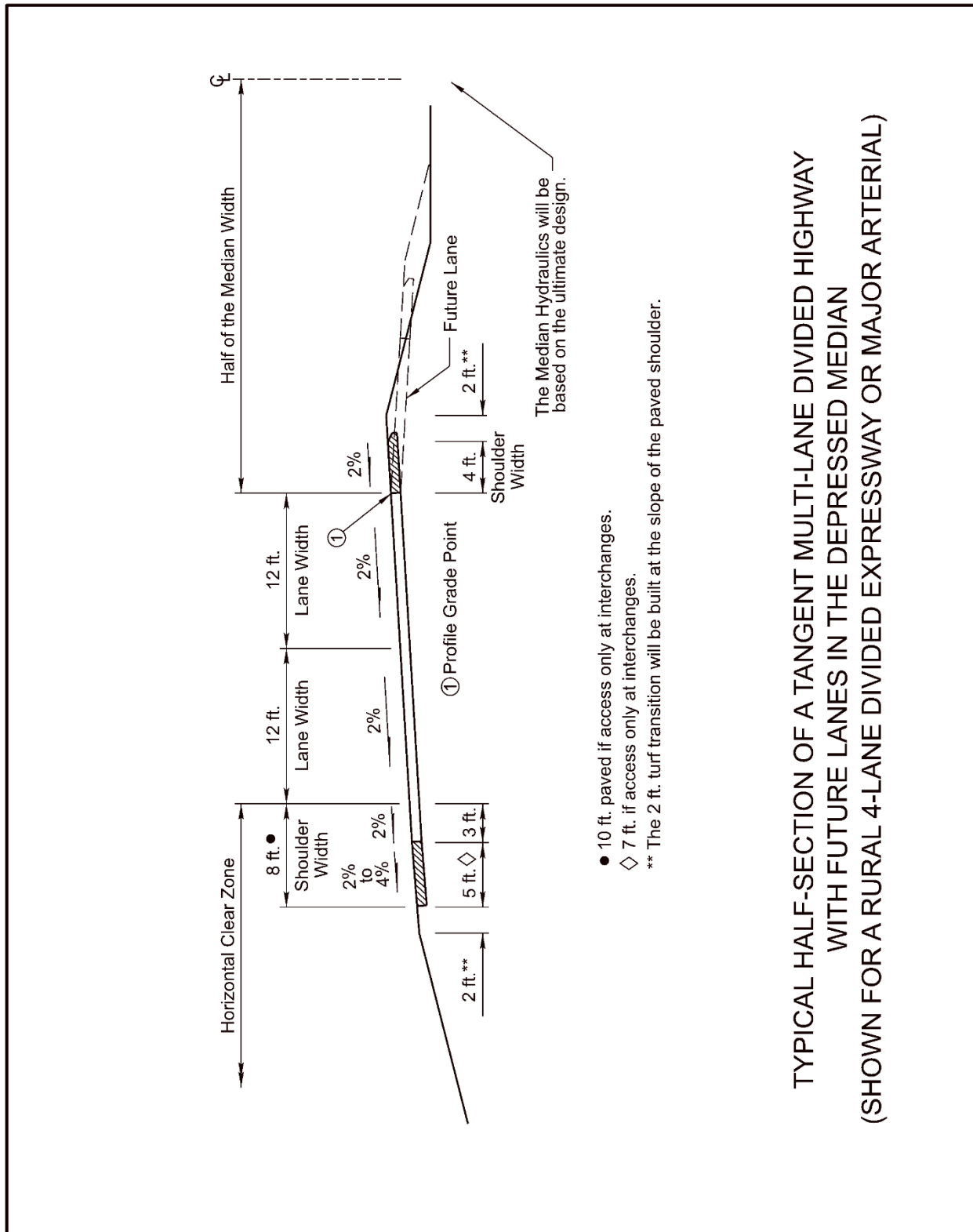
Exhibit 6.5 Typical Section - Rural Major Arterial 400 to 999 ADT





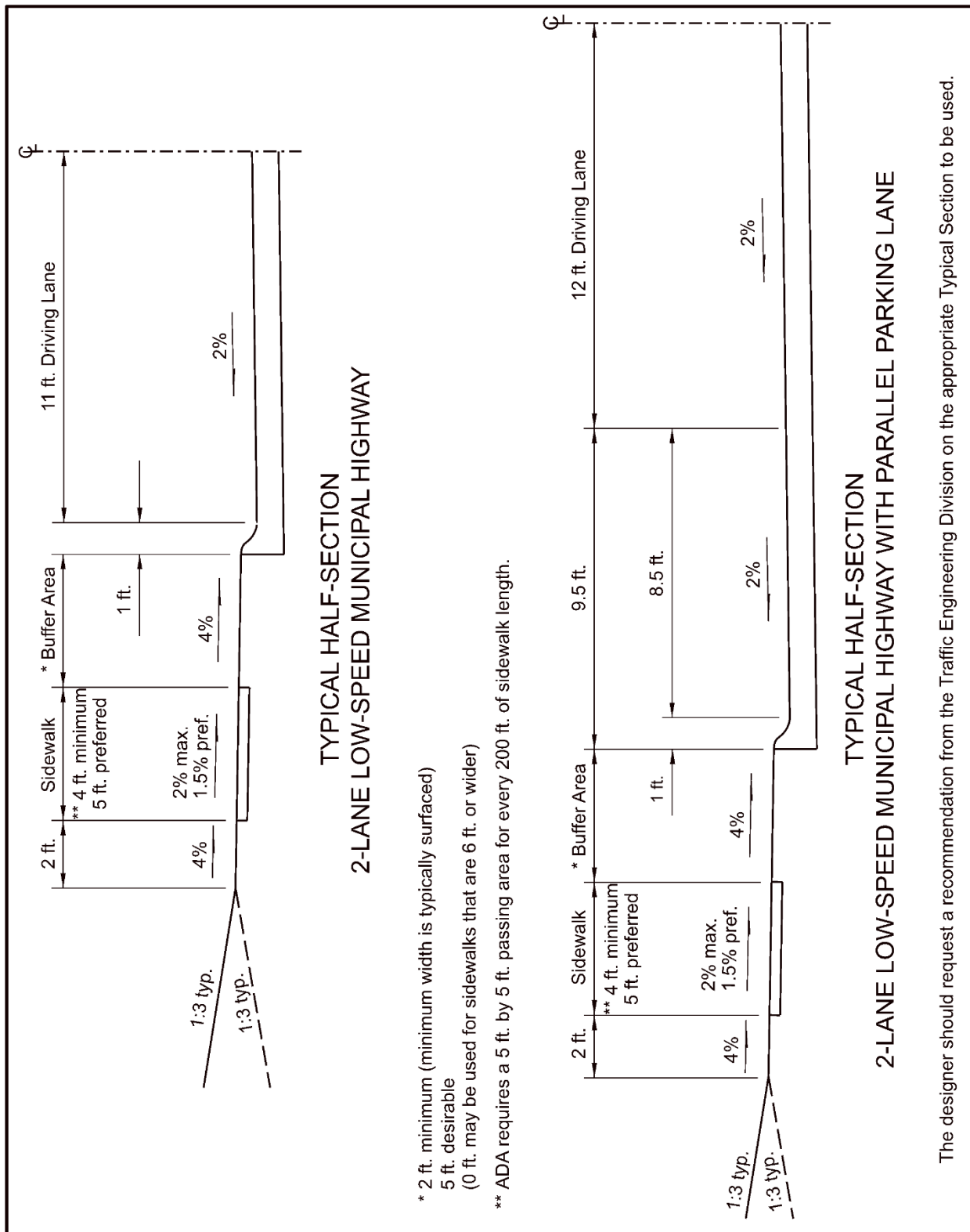
TYPICAL CROSS-SECTION  
 MAJOR ARTERIAL  
 RURAL ROADWAY  
 UNDER 400 ADT

Exhibit 6.6 Typical Section - Rural Major Arterial Under 400 ADT



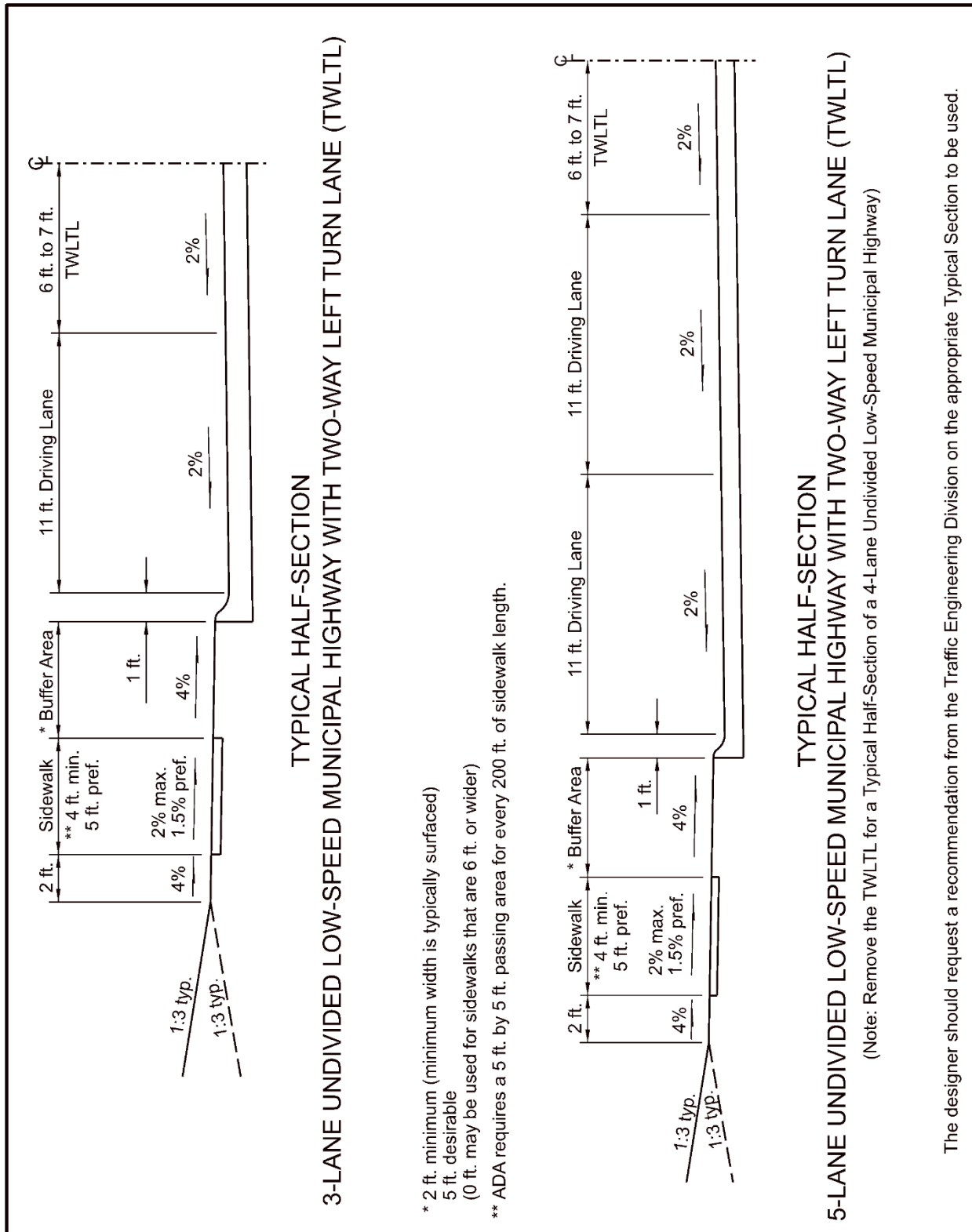
TYPICAL HALF-SECTION OF A TANGENT MULTI-LANE DIVIDED HIGHWAY  
 WITH FUTURE LANES IN THE DEPRESSED MEDIAN  
 (SHOWN FOR A RURAL 4-LANE DIVIDED EXPRESSWAY OR MAJOR ARTERIAL)

Exhibit 6.7 Typical Half-Section of a Tangent Multi-Lane Divided Highway with Future Lanes in the Depressed Median



The designer should request a recommendation from the Traffic Engineering Division on the appropriate Typical Section to be used.

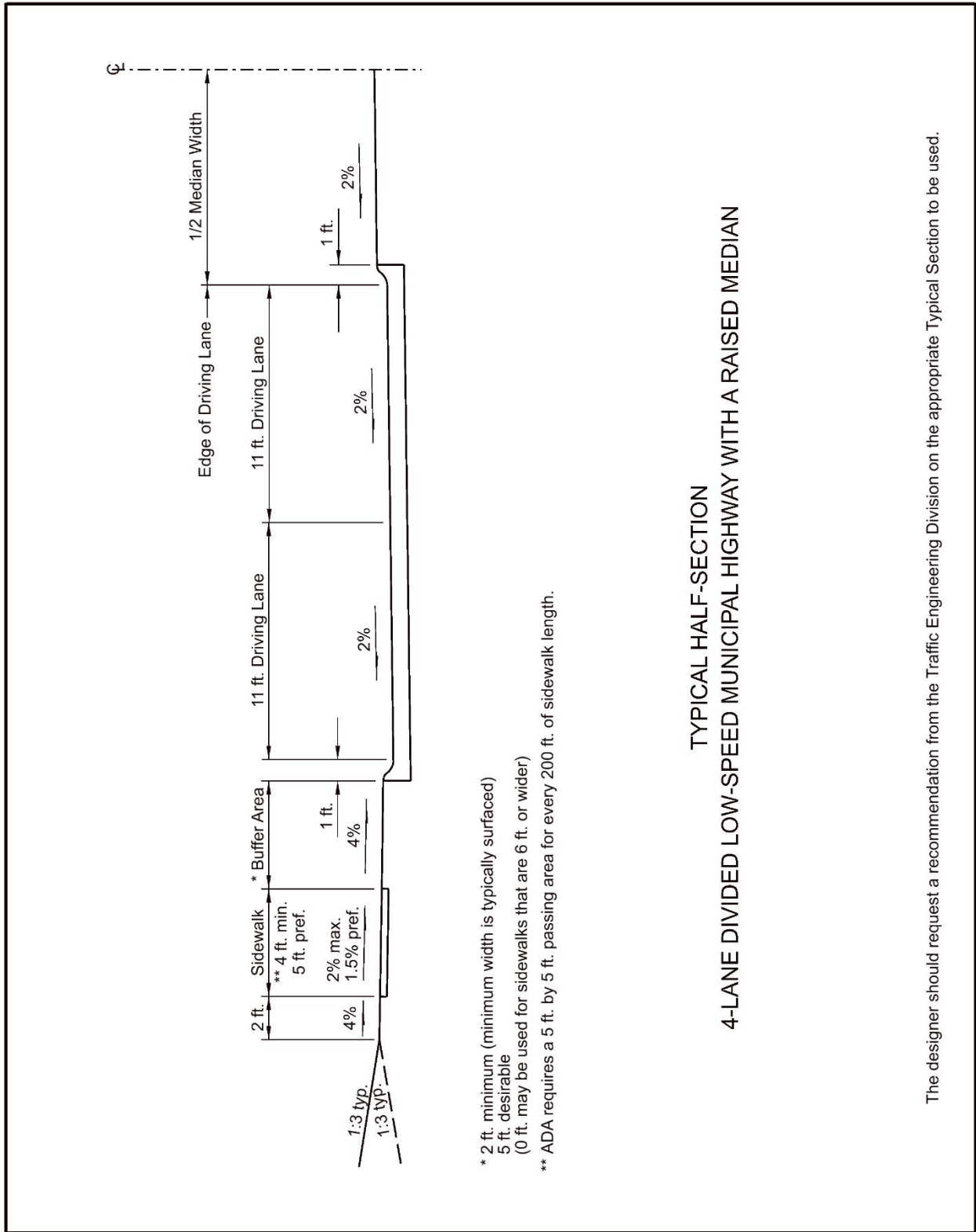
Exhibit 6.8 Typical Half-Sections of Two-Lane Low-Speed Municipal Highways



**Exhibit 6.9 Typical Half-Sections of Three-Lane and Five-Lane Undivided Low-Speed Municipal Highways with Two-Way Left Turn Lanes**

\* 2 ft. minimum (minimum width is typically surfaced)  
 5 ft. desirable  
 (0 ft. may be used for sidewalks that are 6 ft. or wider)

\*\* ADA requires a 5 ft. by 5 ft. passing area for every 200 ft. of sidewalk length.



**Exhibit 6.10 Typical Half-Section of a Four-Lane Divided Low-Speed Municipal Highway with a Twenty Foot Raised Median**

### 3. CURBS

The type and location of curbs affect driver behavior and the utility of a highway. Most commonly found in urban areas, curbs may facilitate:

- Drainage
- Pavement edge delineation
- Delineation of pedestrian walkways
- Traffic channelization
- Access management

#### 3.A Curb Warrants

The selection of a curbed roadway section depends on many factors including, but not limited to:

- Traffic management
- Design speed
- Urban/rural location
- Drainage
- Future or ultimate development
- Construction costs
- At a roundabout

**Urban Locations** - Curbed sections are typically used in urban locations due to:

- Traffic management
- Drainage requirements
- Right-of-way constraints
- Access management

**Rural Locations** - Curbs on rural highways may be warranted for the following conditions, as well as others:

- Traffic management
- Where a raised median is constructed
- Erosion control
- Right-of-way constraints

The need for and location of curbed sections should be discussed during the preliminary design.

### 3.B Curb Types

The three general types of curb are:

1. Barrier: Barrier curbs are relatively steep-faced and are intended to keep the vehicle from leaving the roadway.
2. Mountable: Mountable curbs (e.g. the integral concrete curb) are designed so that errant vehicles can cross them easily.
3. Slope: Sloping curbs are usually three or four inches in height with a simple angular rise. They are also designed to be easily crossed and are preferred over mountable curbs due to ease of hand construction.

Curbs are constructed of either Portland Cement Concrete or asphaltic concrete. Examples of various curb types are shown in [EXHIBIT 6.12](#) and in Standard Plan 301 in the [Standard/Special Plans Book \(Standard Plans\)](#) (Ref. 6.3) (<https://dot.nebraska.gov/business-center/design-consultant/stand-spec-manual/>).

The following guidelines should be used to determine the appropriate curb height:

- High-speed roadways (design speed  $\geq$  50 mph): three-inch asphaltic concrete curb, three-inch concrete slope curb, or four-inch concrete slope curb (See [EXHIBIT 6.13](#)).
- Low-speed roadways (design speed  $\leq$  45 mph): six inch curbs.
- Teardrop islands on side roads intersecting high-speed roadways: inside of the Horizontal Clear Zone of the mainline the curb will be three-inch asphaltic concrete curb, three-inch concrete slope curb, or four-inch concrete slope curb (See [EXHIBIT 6.11](#)).
- Roundabouts: the splitter islands will be six-inch integral concrete curb. A three-inch truck apron curb will be used for the truck apron and a four inch sloping curb will be used for the inner circle of the center island (See [EXHIBITS 6.12 AND 4.2](#)).

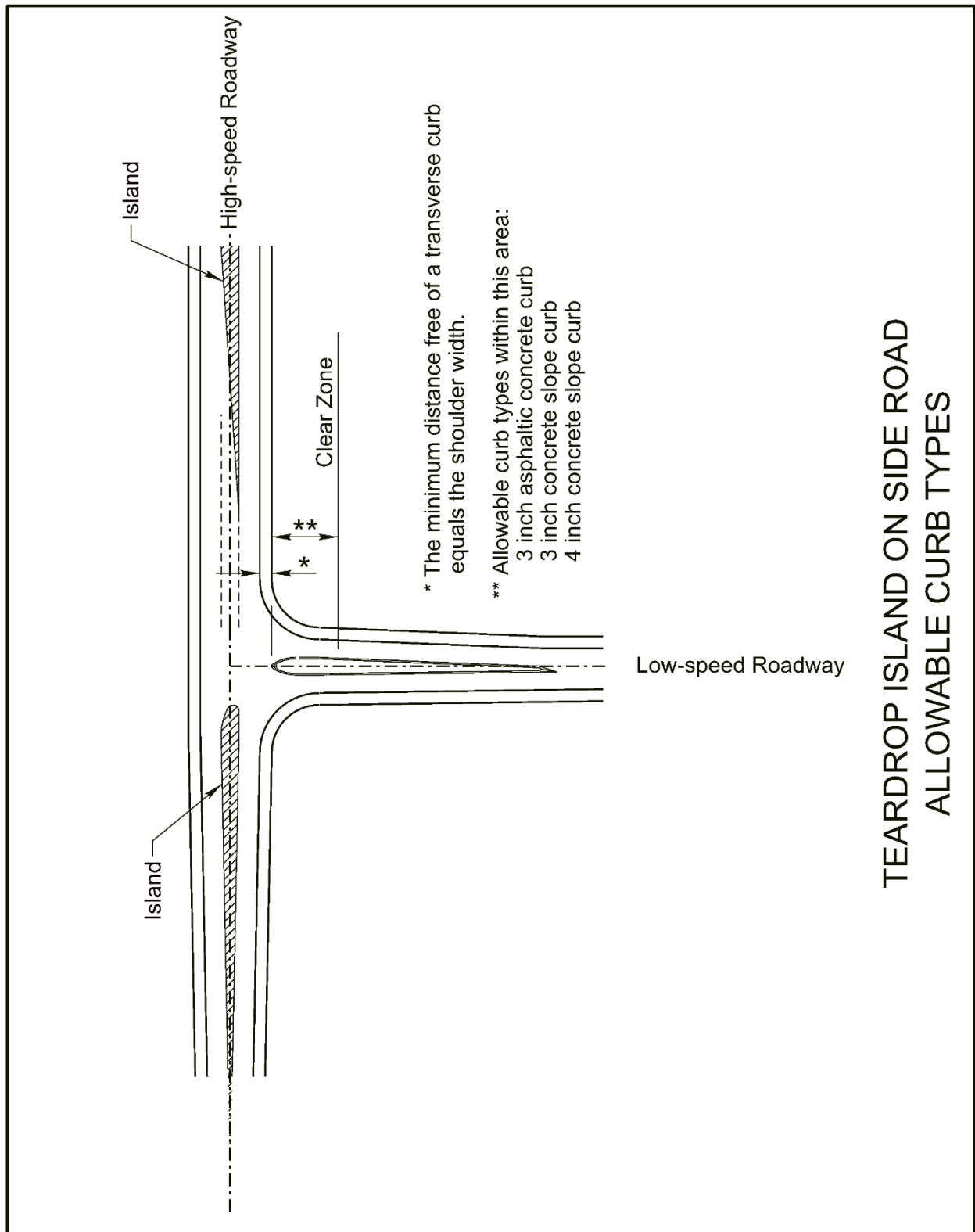


Exhibit 6.11 Teardrop Island on Side Road  
Allowable Curb Types



### 3.C Curb Design Considerations

Drainage - Curb height influences hydraulic design and analysis (See the Drainage Design and Erosion Control Manual (*Drainage Manual*) (Ref. 6.4), Chapter One: Drainage, Section 10) (<https://dot.nebraska.gov/media/qhubv1ji/d-chap-one-drainage.pdf>).

Roadside Geometry - Side slope configuration is based on whether a curbed or uncurbed section is used.

Transitions - EXHIBIT 6.14 illustrates the standard procedure for curbed to uncurbed transition.

Erosive Soils - Curb and concrete flumes may be installed on a project to protect earth shoulders and side slopes from stormwater runoff in regions where native soils are commonly susceptible to soil erosion (such as the Sandhills Region and loess soil areas) (See the *Drainage Manual* (Ref. 6.4), Chapter Two: Erosion and Sediment Control, Section 7.E).

Design Guidelines - The following guidelines have been developed for the design of curbed roadway sections:

1. When curbs are constructed, the top of the abutting turf or sidewalk should be at the same elevation as the top of the curb (See EXHIBITS 6.8, 6.9 AND 6.10).
2. When a curb is used in high-speed conditions (design speed  $\geq$  50 mph), the gutterline of the curb should be located six feet from the edge of the lane or at the edge of the surfaced shoulder width given in the *MDS* (Ref. 6.2), whichever is greater (See EXHIBIT 6.13). The curb may also be located flush with or behind a bridge railing or guardrail.
3. When curb and flume is constructed at the edge of the shoulder, the edge of the through traffic lane will be at the same elevation or higher than the top of the curb to prevent the spread of water onto the high-speed travel lane. The drainage will be designed to conform to the design spread criteria (See the *Drainage Manual* (Ref. 6.4), Chapter One: Drainage Design, EXHIBIT 1.37).
4. When erosion control or sloping curbs are constructed in rural areas the typical section will show the turf transition behind the curb to be a minimum of two feet in width and finished to the top of the curb. Four foot wide turf transitions are preferred if there is an erosion problem or if the project is in the Sandhills region (See EXHIBIT 6.13). A wider turf transition may be necessary if guardrail is installed at curbed sections.
5. Installing an erosion control curb does not change the clear zone requirements presented in the *MDS* (Ref. 6.2).
6. Curb cuts will be provided as required for existing and future access drives (See Chapter Four: Intersections, Driveways and Channelization, Section 2.B, of this manual).

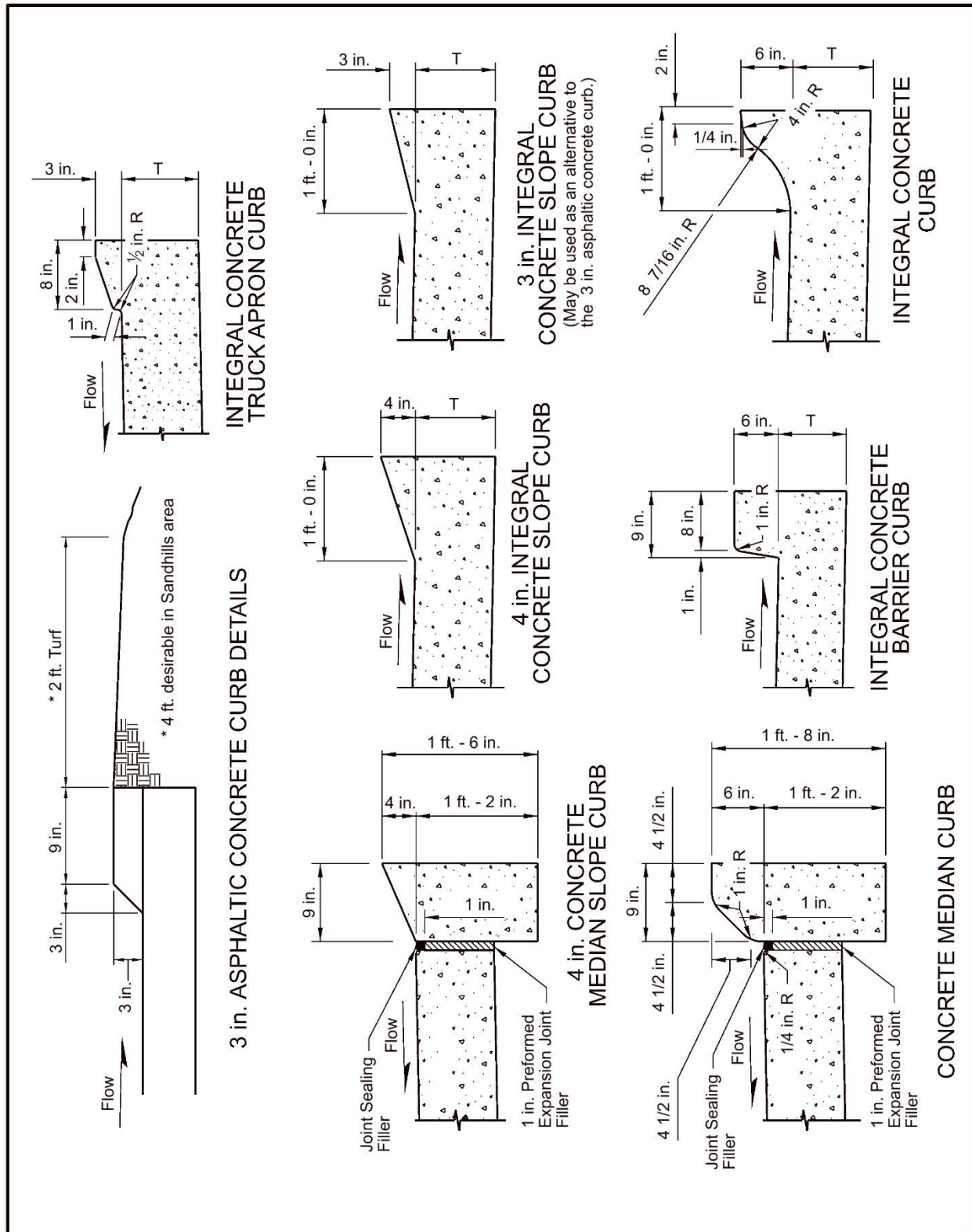
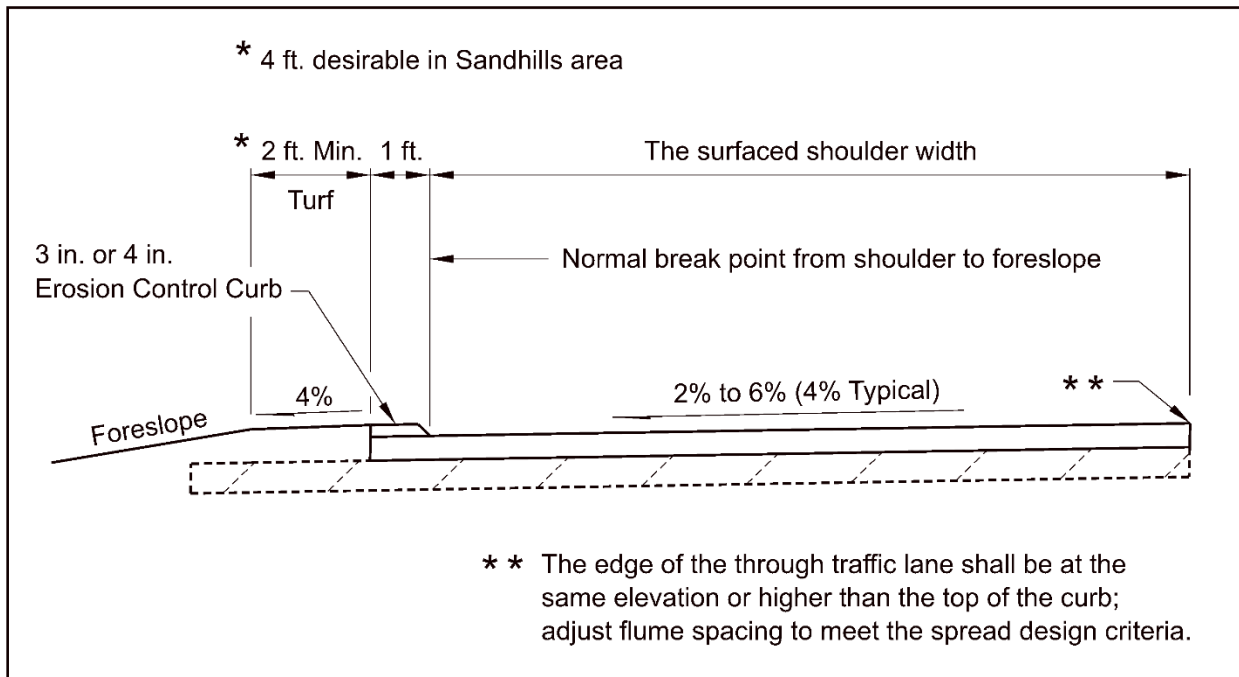
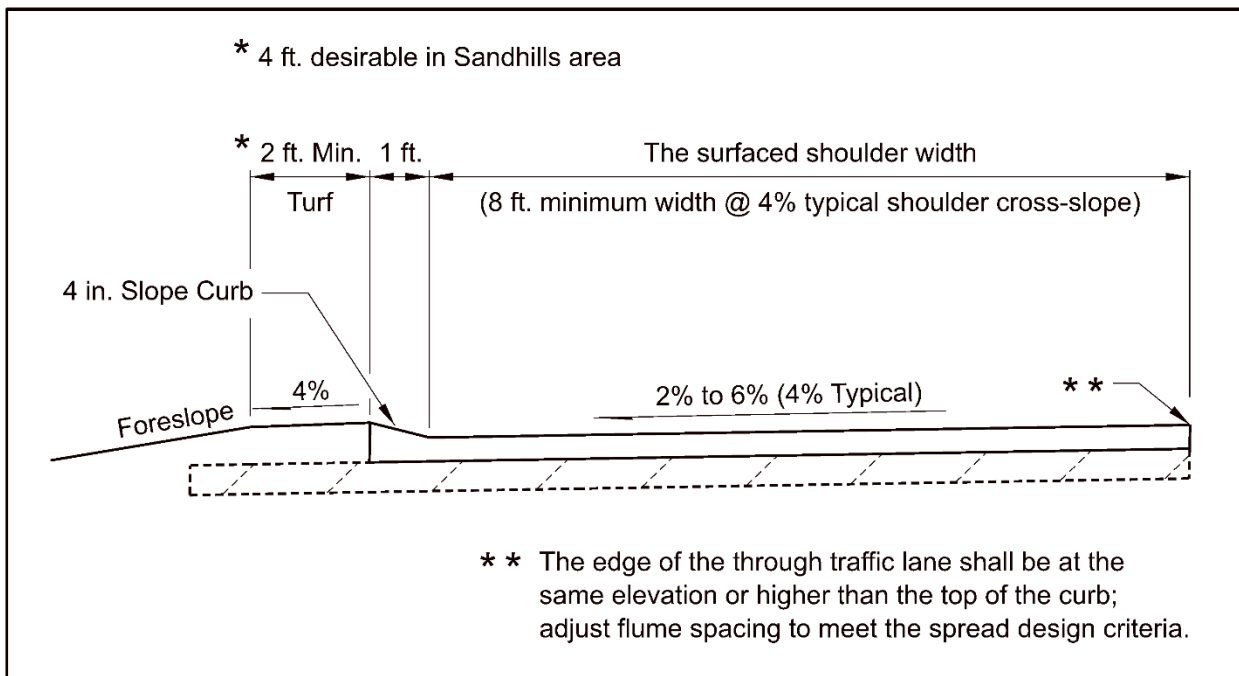


Exhibit 6.12 Typical Curb Details



**3-inch or 4-inch Erosion Control Curb**



**4-inch Slope Curb**

**Exhibit 6.13 Erosion Control Curb Location**

#### 4. ROLLOVER RATES

The rollover rate is defined as the algebraic difference in rate of cross slope between adjacent roadway surfaces. The maximum rollover rates used by **NDOT** are:

- 5% between adjacent lanes for facilities with a design speed  $\geq$  50 mph
- 7% between the lane and shoulder
- 5% for gore areas

The treatment of rollover through superelevated sections is shown in Chapter Three: Roadway Alignment, EXHIBITS 3.3a, 3.4a, & 3.5a.

For additional information see the *Green Book* (Ref. 6.1), Chapter 4, Section 4.9.2, “Superelevated Sections”, and Chapter 9, Section 9.6.4, “Superelevation for Turning Roadways at Intersections”.

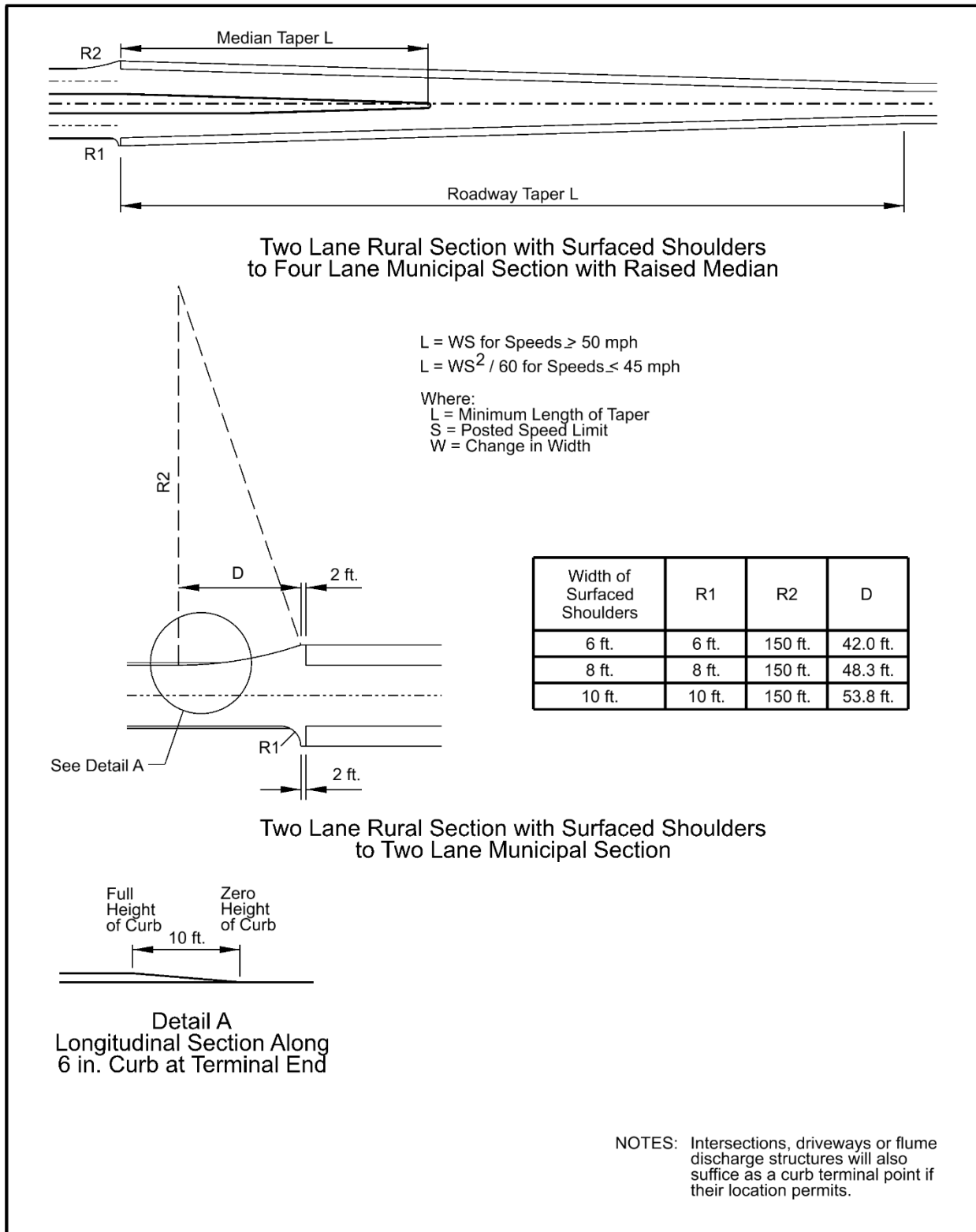
#### 5. TRANSITION

Transition sections are required when one roadway cross-section changes to another roadway cross-section. Locations where transition sections are required include, but are not limited to:

- The change from standard roadway sections to roadway sections with auxiliary lanes
- The change from multilane facilities to two-lane facilities
- At narrow existing bridge structures
- At ramps and turning roadways
- The change from rural to urban sections

EXHIBIT 6.14 illustrates common lane transition configurations.

Transitions for auxiliary lanes, especially turning lanes, often depend on the space available for the transition. Specific criteria for auxiliary lane transition sections and taper rates are discussed in the *Green Book* (Ref. 6.1), Chapter 9, Section 9.7, “Auxiliary Lanes” and Chapter 10, Section 10.9.5.10, “Auxiliary Lanes”.



**Exhibit 6.14 Examples of Rural to Urban Roadway Transitions**

## 6. AUXILIARY LANES

Auxiliary lanes may be added to a roadway for various reasons, including:

- Turn lanes at intersections
- Two-way left-turn lanes
- Truck climbing/passing lanes
- Acceleration/deceleration lanes
- Continuous auxiliary lanes between two closely spaced interchanges

For further information, see Chapter Three: Roadway Alignment, Section 3.A.4 and Chapter Four: Intersections, Driveways and Channelization, Section 1.D of this manual and Chapter 9, Section 9.7, “Auxiliary Lanes”, and Chapter 10, Section 10.9.5.10, “Auxiliary Lanes”, of the *Green Book* (Ref. 6.1).

## 7. ROADWAY CHANNELIZATION

See Chapter Four: Intersections, Driveways and Channelization, Section 5, of this manual and the *Green Book* (Ref. 1.1), Sections 4.11, “Medians”, and 9.6.3, “Islands”.

## 8. NEW FOUR-LANE DIVIDED HIGHWAY USING EXISTING TWO-LANE HIGHWAY (2 + 2 PROJECTS)

The following guidance should be followed when designing a four-lane divided highway which utilizes the existing two-lane roadway:

1. The new lanes and median will be designed to expressway or major arterial crowned standards (See EXHIBIT 6.1).
2. For existing crowned sections with eight foot wide surfaced shoulders which are in relatively good condition, the inside (median) eight foot wide surfaced shoulder should be removed or reduced to four feet in width if required to provide sufficient median width for proper drainage.
3. The location of the axis of rotation and the profile grade point through superelevated sections of the new lanes is illustrated in Chapter Three: Roadway Alignment, EXHIBITS 3.3, 3.4, 3.5, & 3.6.
4. A depressed median should have sufficient width (edge of the driving lane to edge of the driving lane) to provide for proper drainage. The desirable depressed median width for an Interstate is 64 feet and the desirable depressed median width for a four-lane freeway or expressway is 54 feet. For additional information, see Chapter Four: Intersections, Driveways and Channelization, Section 5, of this manual.

For additional guidance, see Chapter Seventeen: Resurfacing, Restoration and Rehabilitation (3R) Projects, Section 1.F, of this manual.

## 9. ROADSIDE DESIGN

### 9.A The Clear Zone

In the late 1960's the forgiving roadside concept was introduced, recognizing that motorists do run off of the roadway and that the number of serious accidents and injuries might be lessened if a traversable recovery area were provided. Ideally this recovery area, the clear zone, should be free of obstacles such as unyielding sign and luminaire supports, trees, non-traversable drainage structures, utility poles, steep slopes, etc. Design options for the treatment of these features have generally been considered in the following order:

- Remove the obstacle or redesign it so it can be traversed
- Relocate the obstacle to outside of the clear zone or to where it is less likely to be struck
- Reduce impact severity by using an appropriate breakaway device
- Redirect a vehicle by shielding the obstacle with a longitudinal traffic barrier and/or impact attenuator
- Delineate the obstacle if other alternatives are not practicable

Clear zone width varies with the roadway functional classification, project type, traffic volume, design speed, roadway location, and the grading section of the roadway. The *MDS* (Ref. 6.2) provides **NDOT** minimum clear zone requirements for various roadway types. For additional information, see Appendix H, "AASHTO Minimum Design Guidance" of this manual and Chapter 3 of the Roadside Design Guide (Ref. 6.6).

#### 9.A.1 Horizontal Clear Zone

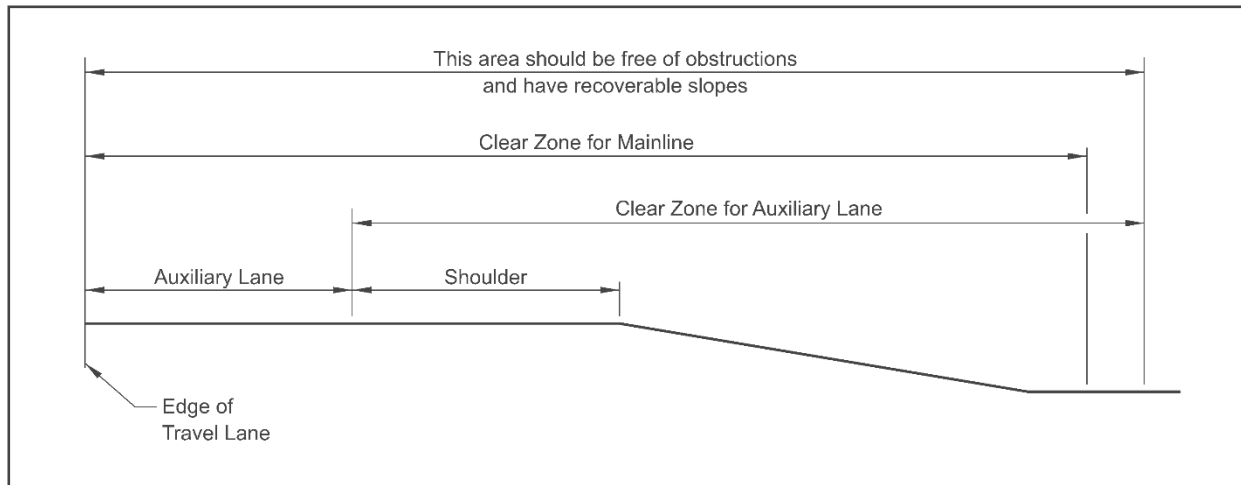
For New and Reconstructed projects, the Horizontal Clear Zone is the roadside area, starting at the edge of the travel lane, which is available for the recovery of errant vehicles. It consists of the shoulder, a recoverable slope, a non-recoverable but traversable slope, and/or a clear runout area. The required Horizontal Clear Zone will vary depending upon the roadway classification (See the *MDS*, Ref. 6.2). Prior to 2016, the *MDS* (Ref. 6.2) referred to the Horizontal Clear Zone as the Lateral Obstacle Clearance.

#### 9.A.2 Fixed Obstacle Clearance

For 3R projects the Fixed Obstacle Clearance, as given in the *MDS* (Ref. 6.2), provides an obstacle free zone in the roadside environment. For additional information see Chapter Seventeen: Resurfacing, Restoration and Rehabilitation (3R) Projects, Section 6.D, of this manual.

#### 9.A.3 Clear Zone Requirements for Auxiliary Lanes

In some instances, it will be necessary to calculate clear zone requirements for both the mainline driving lane and for an auxiliary lane. The clear zone must be calculated for each lane independently, based on the projected traffic volumes and design speeds of the individual lanes (See **TABLE 3.1** of the Roadside Design Guide, Ref. 6.6). The clear zone will be set at the greater of the two distances from the edge of travel way, as shown in EXHIBIT 6.15.



Note: Use the larger clear zone as measured from the edge of the travel lane or from the edge of the auxiliary lane.

### Exhibit 6.15 Clear Zone Application for Auxiliary Lanes Adjacent to Mainline

## 9.B Roadside Geometry (Side Slopes)

The roadside geometry (foreslopes and backslopes) depends on many factors, including:

- The functional classification of the roadway
- Topography
- Urban/rural location
- The presence of curbs
- Snow Control

Criteria for roadside geometry for municipal highways are illustrated in [EXHIBITS 6.8, 6.9 AND 6.10](#). The grading typical sections for rural projects are illustrated in [EXHIBIT 6.16](#). Variations from the typical grading section will require the approval of the **ADE** and the reasons for the variation will be documented in the project file. For additional information regarding roadside geometry, see Section 3.2 of the [Roadside Design Guide](#) (Ref. 6.6).

### 9.B.1 Fill Slopes (Parallel)

Fill slopes within the clear zone should be recoverable slopes (1:4 or flatter) with no protruding fixed objects. Motorists on recoverable slopes generally can either stop their vehicles or slow them sufficiently to enable a return to the roadway. For New and Reconstructed projects, **NDOT** requires 1:6 or flatter slopes to the outside edge of the Horizontal Clear Zone (which is also known as the hinge point).

A non-recoverable traversable slope is defined as a slope which is steeper than 1:4 but equal to or flatter than 1:3. Motorists on non-recoverable traversable slopes generally will not be able to stop their vehicles or return to the roadway but should be able to reach the bottom of the slope without overturning. A section of non-recoverable traversable slope may be contained within the clear zone as long as an unobstructed runout area (which is 1:4 or flatter) is provided beyond the non-recoverable slope (this runout width will be included in the total recovery area).



A side slope which is steeper than 1:3 is considered to be a critical slope (non-recoverable and non-traversable, one on which a vehicle is more likely to overturn). A critical slope should not be included within the clear zone. If a critical slope cannot be eliminated from the clear zone an analysis of the slope will be performed using an applicable computer program (such as RSAP) to determine the economic benefit of installing a roadside barrier system (See Chapter Nine: Guardrail and Roadside Barriers, Section 1.D, of this manual).

For additional information, see Appendix H, "AASHTO Minimum Design Guidance", **Figure 3.2**, of this manual.

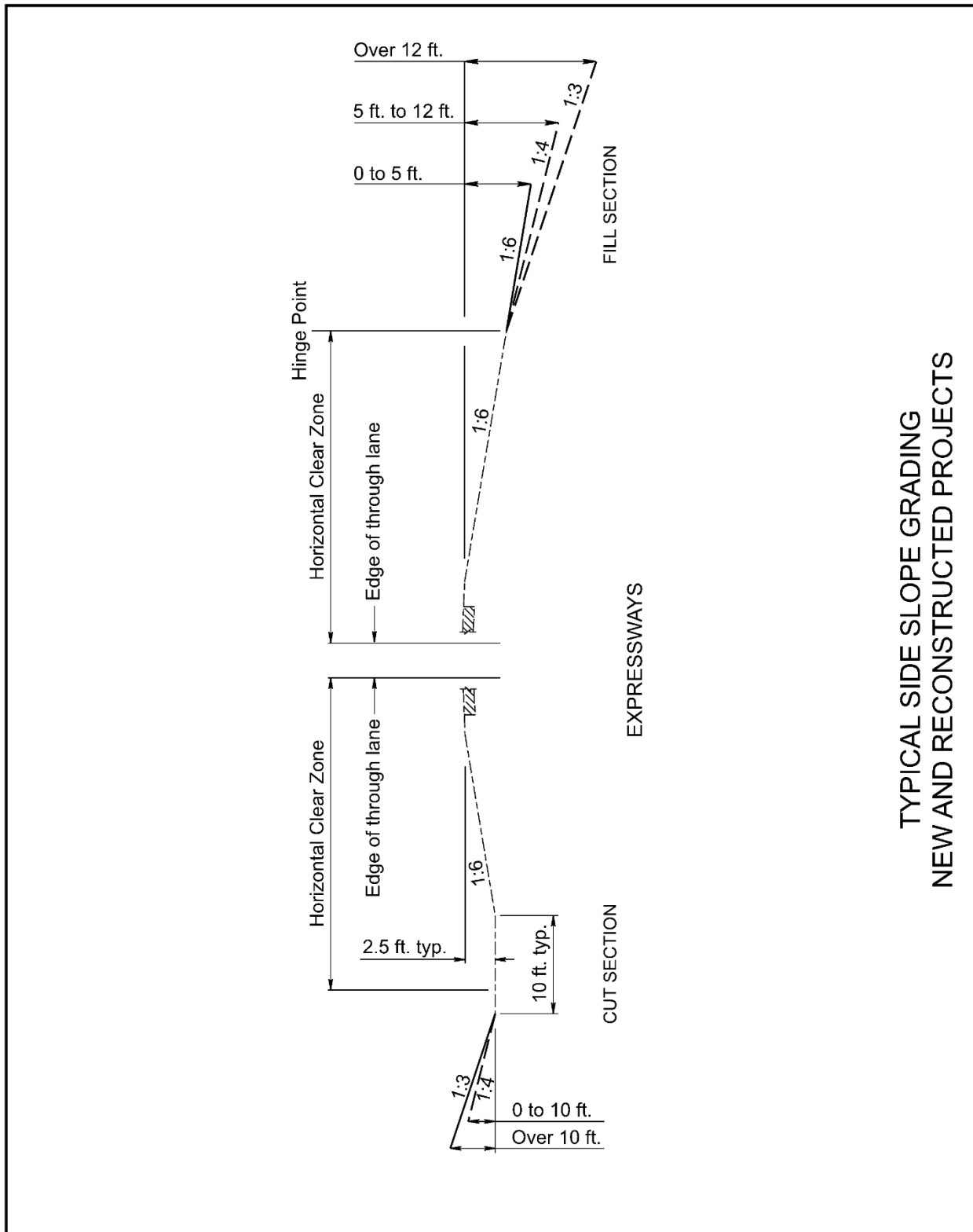
### **9.B.2 Fill Slopes (Transverse)**

Transverse fill slopes caused by the grading at crossroads, driveways/field entrances, median crossings, dikes, etc. are generally more critical to vehicles traveling on the mainline than parallel slopes since the transverse slope is head on to an errant vehicle. Transverse fill slopes of 1:6 or flatter are required within the clear zone on high-speed roadways ( $\geq 50$  mph). The transverse fill slope will be carried to the outside edge of the clear zone and may then be warped to a 1:3 foreslope in a minimum distance of 15 feet (See EXHIBITS 4.14, 4.15 & 4.18). Dikes and median turnarounds in depressed medians will have fill slopes of 1:10.

### **9.B.3 Cut Slopes**

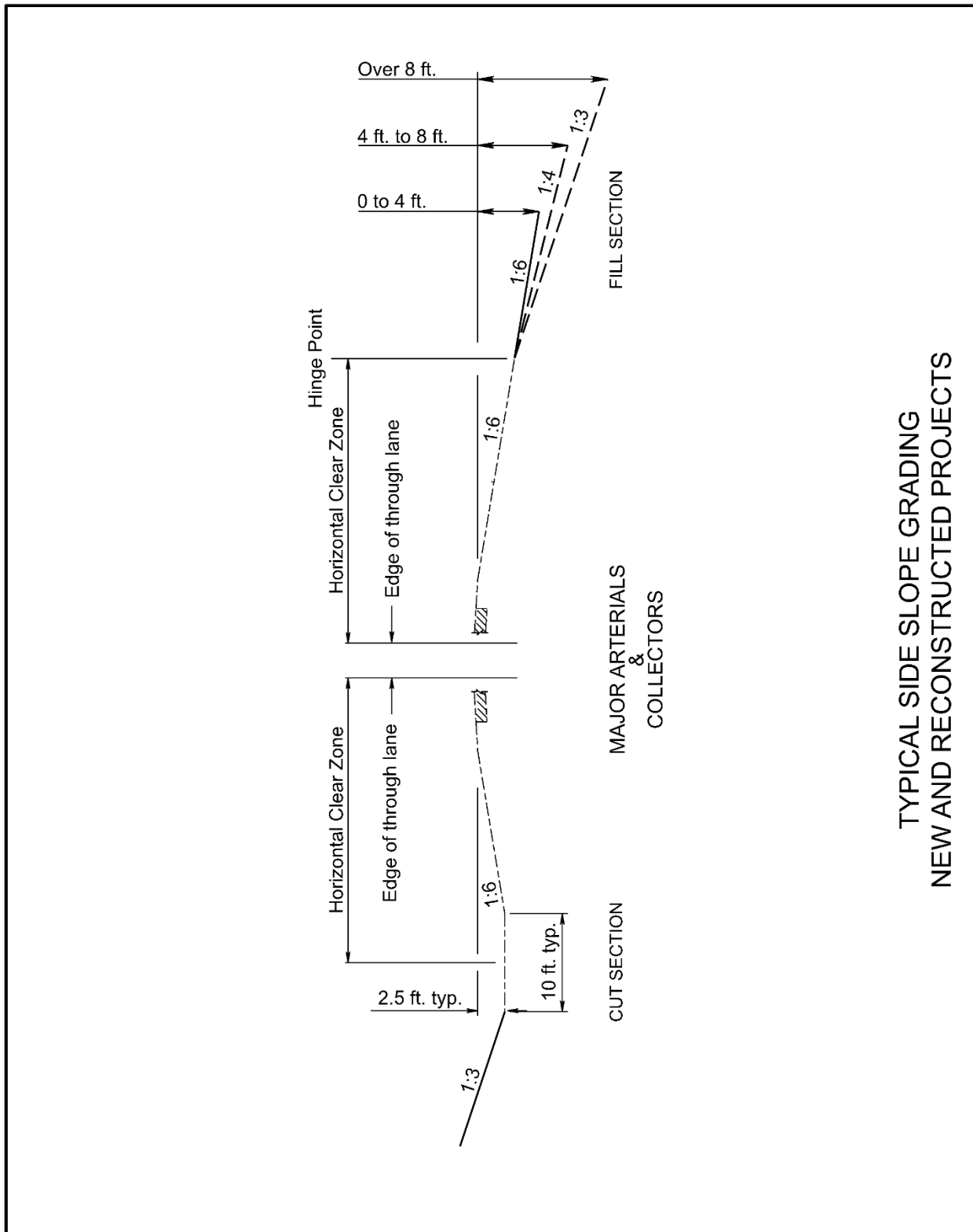
Typical cross-sections of cut slopes can be found in EXHIBIT 6.16. The 10-foot ditch bottom should be considered as the desirable ditch width. This width may be reduced when encountering front yards, mature shelterbelts or trees, center pivots and at other locations where there would be major damages to the property if right-of-way would be acquired based on the 10 foot ditch width. The designer may consider installing curb and/or culvert pipe, when practicable, to reduce right-of-way damages; however, right-of-way should be acquired to or beyond the limits of the clear zone.

The foreslope of a cut section with a special ditch (See Section 10.B of this chapter) should meet the same slope and height criteria as the fill slope requirements presented in EXHIBIT 6.16. Ditches with steep backslopes, such as bench cuts through rock, should be designed so that the backslope is outside of the clear zone.



TYPICAL SIDE SLOPE GRADING  
 NEW AND RECONSTRUCTED PROJECTS

Exhibit 6.16a Typical Side Slopes for New and Reconstructed Projects



TYPICAL SIDE SLOPE GRADING  
 NEW AND RECONSTRUCTED PROJECTS

Exhibit 6.16b Typical Side Slopes for New and Reconstructed Projects

## 10. OTHER ELEMENTS AFFECTING THE ROADWAY CROSS-SECTION

### 10.A Right-of Way

Right-of-way requirements for street and highway design are discussed in Section 2 of the Right-of-Way Design Manual (<https://dot.nebraska.gov/media/0sopjmah/row-manual.pdf>). Right-of-way considerations which may impact the design of the roadway cross-section include, but are not limited to:

- Restricted Right-of-Way - Areas where right-of-way is restricted (e.g. environmental considerations, buildings) may require the use of steeper side slopes, retaining walls, adjustments to the vertical grade to reduce fill heights, and/or the provision of roadside barriers.
- Sight Distance - The purchase of additional right-of-way may be warranted at horizontal curves and intersections to provide and/or maintain the required horizontal sight distances.
- Constructability – Construction easements may be required for construction of bridge structures, for construction equipment access and storage, for materials storage and for other activities required for the construction of the project.

### 10.B Drainage

A roadside ditch will be of sufficient depth to meet the maximum allowable headwater (D + 1) policy (See the *Drainage Manual* (Ref. 6.4), Chapter One: Drainage, Section 8.G).

Ditches which are greater than the normal depths shown in EXHIBITS 6.1 THROUGH 6.6 AND 6.16 are referred to as special ditches. When placing a special ditch, the designer should use a 1:6, 1:4, or a 1:3 foreslope as specified in EXHIBIT 6.16; the grading may go directly to a 1:3 foreslope from the hinge point with **Unit Head** approval and a decision letter to the project file. The minimum special ditch length that will be shown on the Plan and Profile Sheet is 150 feet (See Chapter Eleven: Highway Plans Assembly, Section 4.L, of this manual); the grading contractor will build shorter special ditches based on the project slope stake data. The roadway designer will inform the **Roadside Development Unit** in the **Project Development Division (PDD)** of the location and slope of all ditches for their use in the design of the erosion control.

For curbed facilities, the type of facility limits the maximum width or spread of stormwater from the curb onto the roadway (See EXHIBIT 1.37 of the *Drainage Manual*, Ref. 6.4). Curb height, superelevation, and longitudinal slope all impact drainage design for curbed facilities.

Drainage design is discussed in Chapter One: Drainage of the *Drainage Manual* (Ref. 6.4).

### 10.C Environmental Considerations

It may be necessary to adjust the project side slopes to avoid impacting environmentally sensitive areas. The **Environmental Section** of **PDD** should be consulted about specific problem areas associated with the roadside landscape. Typical environmental considerations that may impact cross-section design include:

- Rare and/or endangered plant species (e.g. Prairie Fringed Orchid)
- Saving established vegetation on existing slopes, where practicable, in the Sandhills Region
- Saving existing trees which are outside of the clear zone but are within the project construction limits, where desired
- Avoiding excavation inside the dripline of a tree, which will damage its roots, if the tree is to be saved (the dripline is the perimeter of the area directly under the crown of the tree)

See Chapter Ten: Miscellaneous Design Issues, Section 4, of this manual for further information.

Changes to the roadway cross-section as it is described in the approved environmental (NEPA) document shall be submitted to the **Environmental Section** in **PDD** for review. For additional information, see Chapter Thirteen: Planning and Project Development of this manual.

### 10.D Erosion Control

Erosion control considerations which may impact the design of the roadway cross-section include, but are not limited to, the following:

- Building curb and flume (See Section 3.C of this chapter)
- Providing flatter side slopes, where practicable, in the Sandhills Region and other areas where roadway side slopes are susceptible to erosion
- MS4 grass swales

See Chapter Two: Erosion and Sediment Control and Chapter Three: Stormwater Treatment of the *Drainage Manual* (Ref. 6.4) for additional information.

### 10.E Geotechnical Features

Geotechnical features within a project may impact cross-section design. The designer should review the soil, subgrade, and materials surveys from the **Materials and Research Division (M&R)** (See Chapter Seven: Earthwork, Section 8, of this manual). Some features which may require special consideration include:

1. Cut or fill sections where the maximum height of cut or fill exceeds 20 feet or where embankment is to be constructed on a weak and compressible foundation material. These concerns are generally discussed in the foundation report and will affect construction phasing.
2. Soil and rock instability in cut/fill sections or natural slopes which are presently or potentially unstable, slide areas, slip plains, and unusual groundwater conditions. Mitigations for unstable conditions, such as geotextile soil reinforcement, permanent ground anchors, wick drains, stone columns, etc. may warrant special consideration.
3. Retaining walls where the maximum height along the length of a geotechnical feature exceeds four feet. Retaining wall design is discussed in Chapter Ten: Miscellaneous Design Issues, Section 8).

### 10.F Snow Control

Ditches may be widened and the backslope laid back from its normal 1:3 slope to provide more area for snow accumulation. See Chapter Ten: Miscellaneous Design Issues, Section 5, of this manual for a discussion of snowdrift abatement techniques.

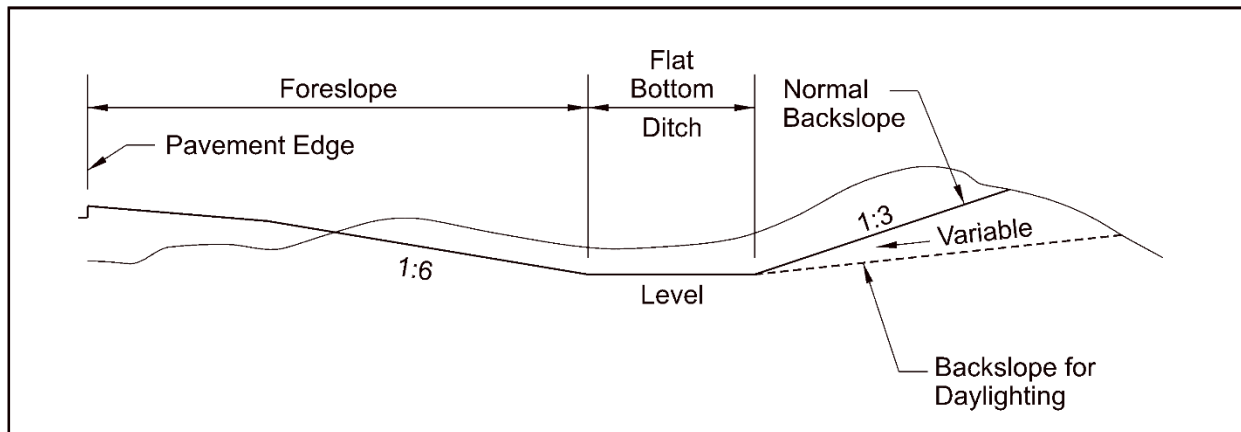
### 10.G Earthwork Balances

Ditches or shoulders may be widened to provide for additional excavation or fill in order to balance the project earthwork (See Chapter Seven: Earthwork, Section 1, of this manual).

### 10.H Daylighting

Daylighting occurs when the roadway backslope is flattened to intersect with the natural ground at a lower elevation than the typical backslope (See EXHIBIT 6.17). Daylighting may be used in order to gain excavation, to improve sight distance, or to eliminate snow drifting. When daylighting is used the following considerations should be taken into account:

- The consequences of removing the earth barrier related to impacts to environmentally sensitive areas, noise pollution, off-roadway glare, driver distraction, view from the roadway and from off of the roadway, and other aesthetic considerations
- Additional right-of-way may be required
- Current drainage patterns will be maintained



**Exhibit 6.17 Daylighting**

### **10.I Utilities**

Highway and street improvements, whether within the existing right-of-way or on new right-of-way, generally entail adjustments of utility facilities. See Chapter Ten: Miscellaneous Design Issues, Section 12, of this manual for further information.

### **10.J Guardrail**

Grading for guardrail may affect the roadway cross-section. See Chapter Nine: Guardrail and Roadside Barriers, Section 3.F, of this manual and the *Standard Plans* (Ref. 6.3) for further information.

### **10.K Bridges**

The **Bridge Division (Bridge)** is responsible for the design of bridges and bridge-sized structures; the designer will coordinate with **Bridge** on projects involving bridges and bridge-sized structures (See Chapter Ten: Miscellaneous Design Issues, Section 2, of this manual). Minimum bridge widths may be found in the *MDS* (Ref. 6.2).

#### **10.K.1 Underpasses**

The cross-section through an underpass should be the same as the approach roadway cross-section, including the clear zone or roadside barriers. Future widening of the roadway should be considered if significant traffic volume increases are anticipated in the foreseeable future (provide sufficient additional width for an additional lane in each direction to be added at a later date).

## 11. REFERENCES

- 6.1 American Association of State Highway and Transportation Officials, A Policy on Geometric Design of Highways and Streets (*Green Book*), Washington D.C., 2018.
- 6.2 Board of Public Roads Classifications and Standards, Nebraska Minimum Design Standards (*MDS*), Current Edition.  
(<https://dot.nebraska.gov/media/1z1n5kmb/nac-428-rules-regs-nbcs.pdf>)
- 6.3 Nebraska Department of Transportation, Standard/Special Plans Book (*Standard Plans*), Current Edition. (<https://dot.nebraska.gov/business-center/design-consultant/stand-spec-manual/>)
- 6.4 Nebraska Department of Transportation, Drainage Design and Erosion Control Manual (*Drainage Manual*), Current Edition.  
(<https://dot.nebraska.gov/business-center/design-consultant/rd-manuals/>)
- 6.5 Federal Highway Administration, Manual on Uniform Traffic Control Devices, (*MUTCD*) 2009. (<https://dot.nebraska.gov/business-center/contractor/mutcd/>)
- 6.6 American Association of State Highway and Transportation Officials, Roadside Design Guide, Washington D.C., 2011.



Chapter Seven presents guidance for the design of New and Reconstructed projects; design guidance for 3R projects is provided in Chapter Seventeen.

## Chapter Seven Earthwork

The following items **are not** earthwork items; **do not** include these items in your grading quantities:

- Shoulder Construction (Surfacing pay item, see Chapter Eight: Surfacing, Section 4.C, of this manual)
- Median Construction (Surfacing pay item, see EXHIBIT 4.27 and the Standard Specifications for Highway Construction (*Spec Book*), Ref. 7.1, Section 308) (<https://dot.nebraska.gov/media/g4qp4y0d/2017-specbook.pdf>)
- Excavation for Box Culverts (Culverts pay item, see Section 702 of the *Spec Book*, Ref. 7.1, and Chapter One: Drainage, Section 8.R, of the Drainage Design and Erosion Control Manual (*Drainage Manual*), Ref. 7.2, <https://dot.nebraska.gov/media/qhubv1ji/d-chap-one-drainage.pdf>)
- Excavation for Culvert Pipes and Headwalls (Culverts pay item, see Section 702 of the *Spec Book*, Ref. 7.1, and Chapter One: Drainage, Section 8.R, of the *Drainage Manual*, Ref. 7.2)
- Excavation for Structures (e.g. abutments, piers, bents; see Section 702 of the *Spec Book*, Ref. 7.1)

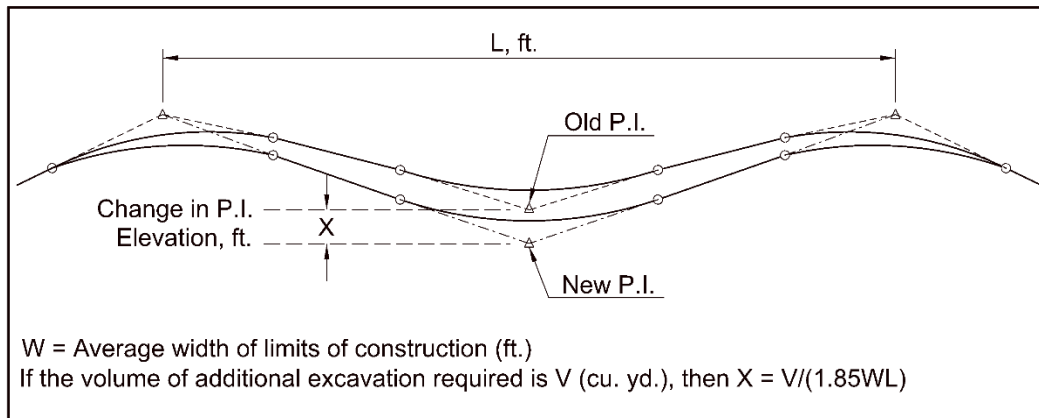
### 1. EARTHWORK

Earthwork is composed of two main components, excavation and embankment. Excavation is the amount of material that must be "cut" to construct the proposed roadway, ditches, channels, entrances, and other associated components. Embankment is the amount of material that must be "filled" to construct the proposed roadway and its associated components.

Projects in rural areas should be designed to produce balanced earthwork; the excavation should equal the embankment as adjusted by the balance factor (See Section 1.A.1 of this chapter). Grade adjustments are the generally preferred method used to balance the earthwork. The approximate change in the elevation of a vertical PI required to produce a given volume of material can be computed using the formula found in EXHIBIT 7.1. When it is not possible, or practicable, to balance the earthwork, provisions must be made to borrow or waste material as necessary (See Section 1.B of this chapter).

Adjustments to the project grading must be weighed against impacts to environmentally sensitive areas, safety criteria, possible aesthetic damage, and maintenance problems in these areas. Changes to the horizontal and/or vertical alignments as described in the approved environmental (NEPA) document shall be submitted to the **Environmental Section** in the **Project Development Division (PDD)** for review.

In urban areas, other considerations (e.g. limiting right-of-way impacts and matching elevations of existing development) may have a higher priority than balancing the earthwork.



**Exhibit 7.1 Earthwork Computation Formula**

### 1.A Computations

Earthwork computations are used to determine pay quantities and to verify final calculations in the field. There are a variety of computer programs available for earthwork computations. Although the methods may vary, the basic approach is the same; the following data is entered into the program:

- Cross-sections of the existing terrain
- The horizontal and vertical alignments
- The design cross-sections
- Surface of the existing terrain

Utilizing this data, the computer program will:

- Compute cross-section end areas of cut and fill
- Compute volumes of excavation and embankment
- Establish balance points and perform an earthwork distribution analysis
- The computer software can also do surface to surface calculations of excavation and embankment (e.g. for roundabout intersections, interchanges, wetlands)

Earthwork does not begin or end at the projects' beginning and end stations, the roadway designer should transition the earthwork from a no grading section to the full grading section. The transition will establish L.O.C.s to determine if right-of-way or construction easements are required, if there are any environmental and/or utility impacts and will improve the earthwork totals. This transition length may be as little as 0.01 foot but should not exceed 200 feet.

### 1.A.1 Balance Factors

Earthwork is balanced when the amount of available excavation equals the amount of embankment required after compaction. When soil is excavated, hauled, and compacted into an embankment the final volume of the compacted soil is usually less than when it is in its natural state. This difference in volume is defined as shrinkage. When rock is excavated, broken, and placed into an embankment it will occupy more space than rock in solid form due to the increase in void spaces. This increase in volume is known as swell. Balance factors are multipliers applied to the embankment volumes to adjust for the shrinkage or swell of the fill material. The balance factor also accounts for loss of material during haul and for ancillary construction items such as driveway construction. In most cases one balance factor is used for an entire project; an average balance factor must therefore be determined for the various materials encountered over the length of the project. Balance factors should be discussed with the **District Engineer (DE)** on the plan-in-hand field inspection, based on previous similar projects and individual design experience. The **Materials and Research Division (M&R)** may also be consulted for recommendations.

### 1.A.2 Distribution Analysis

Distribution analysis calculates the accumulation of excavation obtained and embankment required, Station by Station, over the length of a project. Distribution analysis helps the designer to determine if the earthwork is going to be balanced, borrowed, or wasted.

When the adjusted embankment required exceeds the amount of excavation available, borrow is required from borrow pits.

Waste occurs when the amount of available excavation exceeds the amount of needed embankment. The leftover material must be disposed of at approved waste sites or it may be used for shoulder construction (shoulder construction **is not** a part of the earthwork, it is a surfacing item and is paid for by the station, see Chapter Eight: Surfacing, Section 4.C, of this manual).

It should be determined at the plan-in-hand field inspection whether a project will be balanced with material from the right-of-way, using borrow, or if it will be necessary to waste excess material.

Considerations in determining if balanced earthwork is practicable for a given project include:

- Right-of-way limitations
- Impacts to environmentally sensitive areas and other environmental considerations
- Archaeological and historical considerations
- Matching existing elevations at cross roads, bridges, railroad crossings, etc.
- The availability and quality of borrow sites within the vicinity of the project
- The availability of waste sites within the vicinity of the project
- Would balancing the earthwork require crossing bridges or going through towns with earth hauling equipment

Information regarding the distribution of earthwork is required for the project; the following information must be provided in the distribution analysis for each station:

- End areas in sq. ft. of excavation and embankment
- Accumulated volume of excavation
- Accumulated volume of embankment
- Added quantities for intersections, large driveways, etc.
- Balance factor(s)
- Mass ordinate

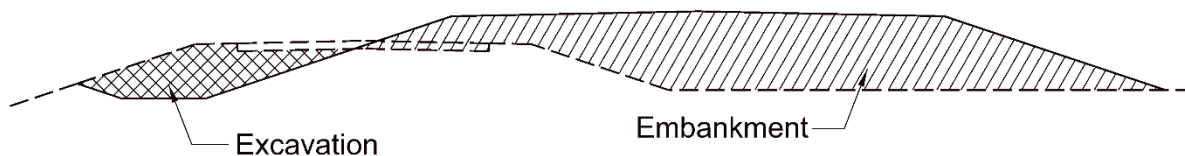
The above information, together with the identification of approximate balance points, is considered adequate. Mass diagrams are not generally plotted for the project plans. The computer program provides a summary of the earthwork distribution analysis.

The following guidelines should be used when performing the earthwork distribution analysis:

1. Desirable balance lengths should be between one half mile and one mile in length, the preferred length is one mile.
2. Short balances of 300 feet or less should not be shown on the plans but should be shown as part of a combined larger balance.
3. For rural projects constructed under traffic, earthwork distribution analysis for the left and right sides of the roadway will be computed separately, for information only, so the contractor knows how much material must be hauled across traffic.
4. The earthwork should balance at bridges, railroad crossings, major highway intersections, both sides of towns, rivers or major streams, or other natural breaks.
5. When a project includes phasing, an earthwork analysis should be developed and quantities shown on plans, for information only, for each phase of construction (See Section 2 of this chapter).
6. The volume of existing pavement to be wasted or salvaged will be eliminated from the excavation and filling the void caused by the removal of the pavement will be included in the embankment in the earthwork run (See [EXHIBIT 7.2](#) and Section 1.C of this chapter).

Note:

In calculating the earthwork quantities, a nine inch depth void representing the existing pavement removal has been accounted for in both excavation and embankment.



**Exhibit 7.2 Existing Pavement Removal in Earthwork**

7. Earthwork in urban areas should be paid for as either "Excavation Established Quantity" or "Earthwork Measured in Embankment" (See Section 5.E of this chapter). Earthwork will not usually be balanced for urban projects.
8. Earthwork quantities for temporary roads may be determined using established quantities where the temporary road material is put in as embankment and removed as excavation specified for the temporary road. Earthwork quantities for temporary roads may also be incorporated in the roadway earthwork if the designer includes the temporary road structure in the computer input.

#### **1.A.2.a Haul Considerations**

Haul is the distance excavated material is moved from the location where the material is obtained to the location where the material is to be deposited; haul distances should be kept to a minimum. When a distribution analysis is performed, the following questions should be considered:

1. Is waste available from the other side of the road?
2. Is waste available from adjacent balances?
3. Is borrow available?
4. Can the balance points be adjusted?

#### **1.A.3 Moisture Content**

The moisture content of the soil placed in the embankment at the time of compaction must be within the moisture range designated in the Soils and Situation Report (See Section 7.A.3 of this chapter). When the moisture content of the soil is not within the acceptable range, either water must be added to the soil or the soil must be aerated. When calculating grading item quantities, EXHIBIT 7.3 should be used to estimate the amount of water which must be applied to obtain the optimum moisture content. EXHIBIT 7.3 is based on excavation quantities; adjustments are required when paying for the quantity "Earthwork Measured in Embankment" (See Section 5.A of this chapter).

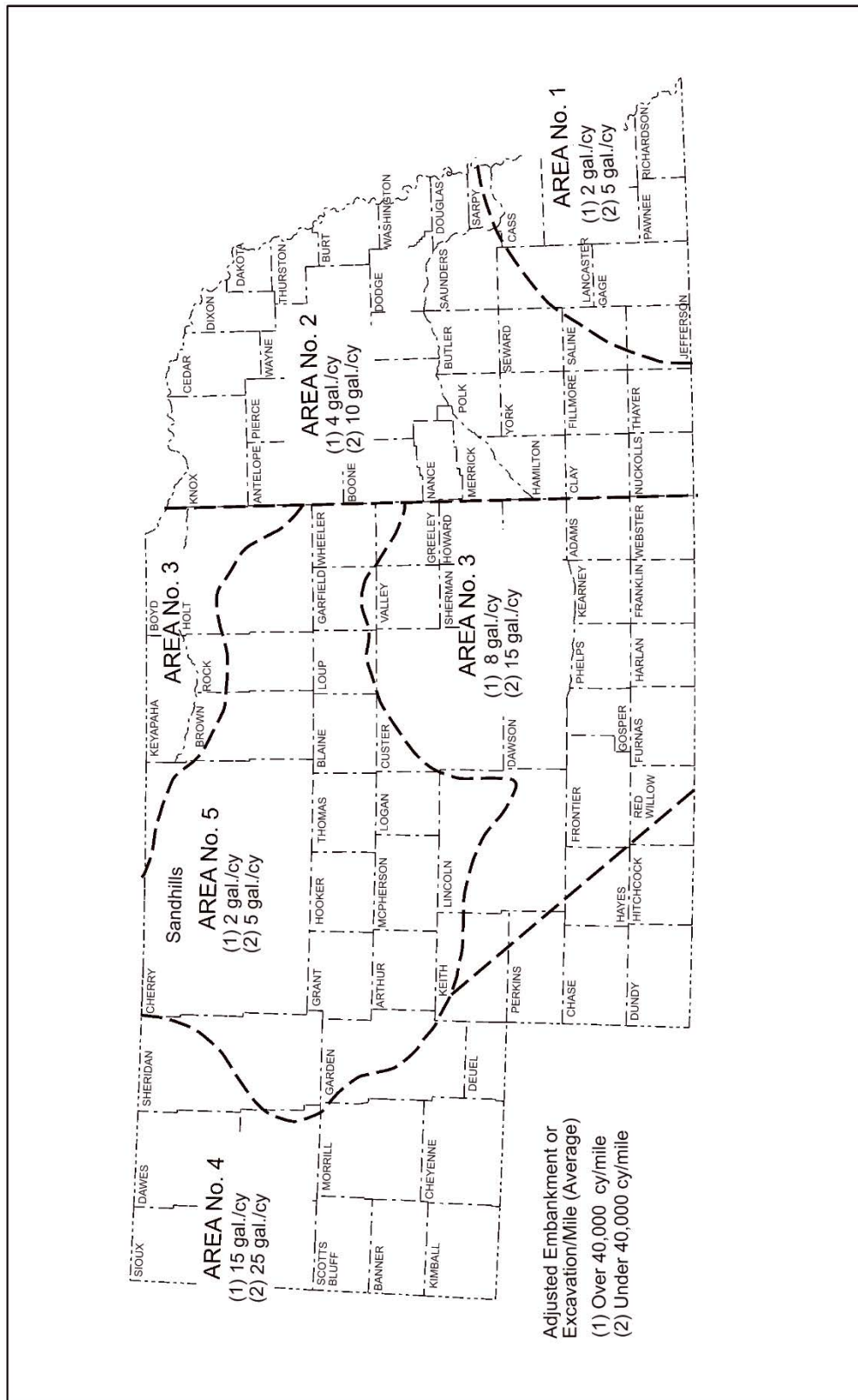


Exhibit 7.3 Map for Estimating Water Needed for Compaction

## 1.B Borrow Pits and Waste Sites

Borrow pits are sources of approved material required for the construction of embankments or other earthwork requirements on the project (e.g. earth dikes).

Waste sites are areas established for the disposal of excess excavation.

The following items should be considered for borrow pits and waste sites on New and Reconstructed projects:

1. The options available to balance the project or reduce borrow and/or waste.
2. When the use of borrow pits and/or waste sites is required, locations should be discussed on the plan-in-hand field inspection.
3. Costs may be held to a minimum by obtaining borrow from wetland mitigation sites to be built with the project, existing borrow pits, snow control areas, etc.
4. Locations for borrow and waste sites should be finalized before Roadway Design Details plans (Clarity Task 5508) are transmitted to **Right-of-Way Design (ROW)**.
5. Borrow pits and waste sites require clearance for historical and environmental impacts. If there are changes to these sites after the R.O.W. Appraisal Plans have been designed, the roadway designer will notify the **State Historical Preservation Officer** and the **Environmental Section Manager** in **PDD** (See Chapter Thirteen: Planning and Project Development, Section 5, of this manual).
6. If state-owned land is used for a borrow pit, restoration of the site is required. See Section 208 of the *Spec Book* (Ref. 7.1).

### 1.B.1 **Alternatives to Providing Borrow or Waste Sites**

#### 1.B.1.a **Borrow Alternatives**

1. Daylighting: Daylighting is the flattening of the roadway backslope so that it intersects the natural ground at a lower elevation than the normal backslope (See Chapter Six: The Typical Roadway Cross-Section, Section 10.H, of this manual).
2. Ditch Widening: If adequate right-of-way is available, ditches may be widened to provide additional excavation. When ditch widening is used it should be uniform in cross-section and consistent in application, with gradual transitions between ditch widths.
3. Flattening Backslopes: If adequate right-of-way is available, backslopes on ditches may be flattened from 1:3 up to 1:4 to gain additional excavation. As with ditch widening, backslope flattening should be uniform in cross-section and consistent in application, with gradual transitions between slope changes.
4. Special Ditches: A special ditch is a ditch that varies in slope or depth from the standard ditch shown on the typical cross-section (See Chapter Six: The Typical Roadway Cross-Section, Section 10.B, of this manual). If adequate right-of-way is available, special ditches may be designed to increase the available excavation as well as to provide better drainage.
5. Modify Alignments: The horizontal and vertical alignments may be adjusted to eliminate or reduce the need for borrow. Changes to the alignments as described in the approved environmental (NEPA) document shall be submitted to the **Environmental Section** in the **PDD** for review.

### 1.B.1.b Waste Alternatives

1. Flattening Foreslopes: If adequate right-of-way is available, foreslopes may be flattened from 1:6 up to 1:10 to eliminate or reduce the need to waste material. Flattened foreslopes should be uniform in cross-section and consistent in application, with gradual transitions between changes in slopes. The designer should keep additional right-of-way to a minimum.
2. Fill Low Areas: Additional excavation may be placed in low areas outside of the construction limits and within the right-of-way, provided that the fill does not adversely affect environmentally sensitive areas, drainage, or aesthetic conditions.
3. Modify Alignments: The horizontal and vertical alignments may be adjusted to eliminate or reduce the amount of waste. Changes to the alignments as described in the approved environmental (NEPA) document shall be submitted to the **Environmental Section** in **PDD** for review.

### 1.C Removal of Existing Surfacing

“Removal” is generally a pay item when surfacing material is to be salvaged (See Chapter Eight: Surfacing, Section 5.B, of this manual for further information).

#### 1.C.1 Rural Projects

On full grading projects the existing asphaltic concrete (asphalt) surface will normally be salvaged; existing Portland Cement Concrete (concrete) surfacing may be salvaged. The roadway designer should check with **M&R** during “Roadway Design” (Clarity Task 5350) to determine the location, depth, width, and length of the material that is to be salvaged. The preliminary cross-sections should reflect the void left by the existing surface that is to be removed. The removal of this material will be paid for directly as a separate pay item.

If the existing surfacing is asphalt and will not be salvaged, this surfacing may be disposed of in the outer slopes of the embankment, one foot below the finished shoulders and foreslope, after review by the **Location Studies Unit** in **PDD** (See Chapter Thirteen: Planning and Project Development, Section 5.H.1, of this manual). No deductions to the earthwork quantities are required for the volume occupied by this surfacing and no direct payment will be made for the removal. For additional information see the *Spec Book* (Ref. 7.1).

If the existing concrete surfacing is to be removed, the roadway designer should deduct the volume occupied by this surfacing in computing the earthwork balance and the removal should be paid for directly (See EXHIBIT 7.2). If the concrete is to be removed, crushed, and replaced as foundation course, the removal is subsidiary to the “Crushed Concrete Foundation Course” pay item as long as the crushed concrete is only used for the foundation course.

When less than three feet of embankment is to be placed over an existing concrete pavement or base course, the existing surfacing will be removed and paid for directly. If there is to be over three feet of embankment placed on top of existing concrete surfacing, the concrete will be broken into approximately four foot by four foot square pieces and left in place. The pay item “Breaking Pavement” will be defined by a special provision and is paid for by the sq. yd.



### 1.C.2 Urban Projects

Normally there is no place to bury existing surface material on urban projects, therefore removal is usually specified. In this case the roadway designer should deduct the volume occupied by this surfacing in computing the earthwork and the removal should be paid for directly.

Alternatively, asphalt may be milled and salvaged. In this case, it is paid for as milling and the quantity is deducted from the earthwork.

If the project covers both rural and urban areas, the plans will show the limits of asphalt removal to be paid for (urban areas) and the limits of asphalt removal which is subsidiary to excavation (rural areas).

## 2. STAGED CONSTRUCTION/PHASING

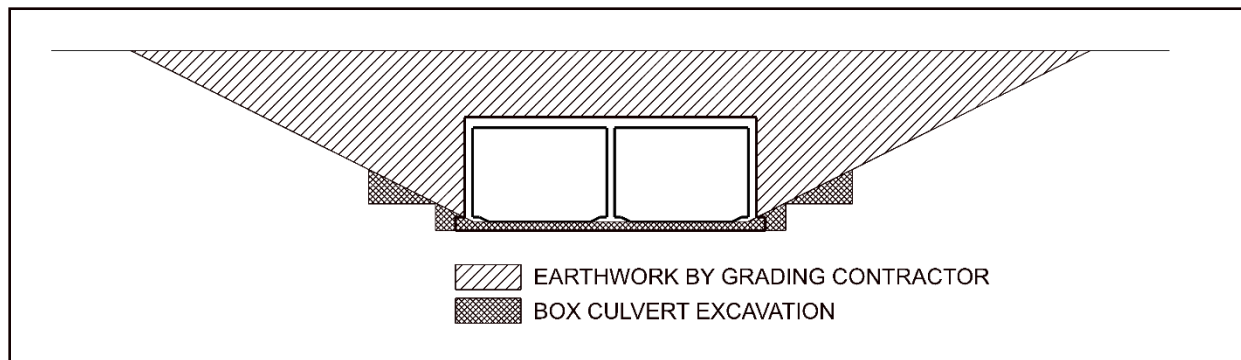
For projects with phased construction (e.g. Interstate, freeway, and expressway projects), a distribution analysis shall be done for each separate phase of construction (See Section 1.A.2 of this chapter). Cross-section cut and fill areas should reflect the staged construction and should correspond with the distribution analysis performed. The cross-sections will show earthwork quantities for each phase of construction and the General Information Sheet (See Chapter Eleven: Highway Plans Assembly, Section 4.G, of this manual) should show the earthwork quantities in tabular form for each phase of construction. A phased project may include both borrow, as new lanes are constructed, and waste earthwork at the finish of the project (See Section 1.B of this chapter). The distribution analysis for the phased construction is for information only, unless the quantities are “Established Quantities” (See Section 4.B of this chapter). Although it is the roadway designer's responsibility to provide reasonable phasing, demonstrating that construction is possible, the actual construction phasing is left to the discretion of the contractor with the approval of the **Project Engineer**. For additional information see Chapter Fourteen: Traffic, Section 6, of this manual.

When a project requires more than one construction season, cover crop seeding will be calculated for each phase of construction. The General Information Sheet will show the quantity of cover crop seeding required for each phase (See the *Drainage Manual* (Ref. 7.2), Chapter Two: Erosion and Sediment Control, Section 5.B).

### 3. MISCELLANEOUS EARTHWORK CONSIDERATIONS

#### 3.A Bridge Replaced with a Box Culvert

The excavation for the box culvert is the responsibility of the culvert contractor and will not be included in the roadway grading. The roadway grading *will* include the earthwork required to bridge the channel and bring the roadway to finish grade, minus the box volume and the backfill required to bring the box excavation to the existing channel section (See [EXHIBIT 7.4](#)). For additional information on box culvert excavation, see the *Drainage Manual* (Ref. 7.2), Chapter One: Drainage, Section 8R.



**Exhibit 7.4 Earthwork at a Bridge Replaced with a Box Culvert**

#### 3.B Unsuitable Materials

Unsuitable materials are inappropriate for use in the embankment. They include rock, organic muck, or foreign objects such as garbage, car bodies, etc. The Soil and Situation Report will list the location, type of material, and treatments for the unsuitable material identified on the project. If unsuitable material is unexpectedly encountered by the contractor, a change order (a written order to the contractor covering changes in the contract) will be required to treat the unsuitable material (See Chapter Thirteen: Planning and Project Development: Section 5.H, of this manual for additional information).

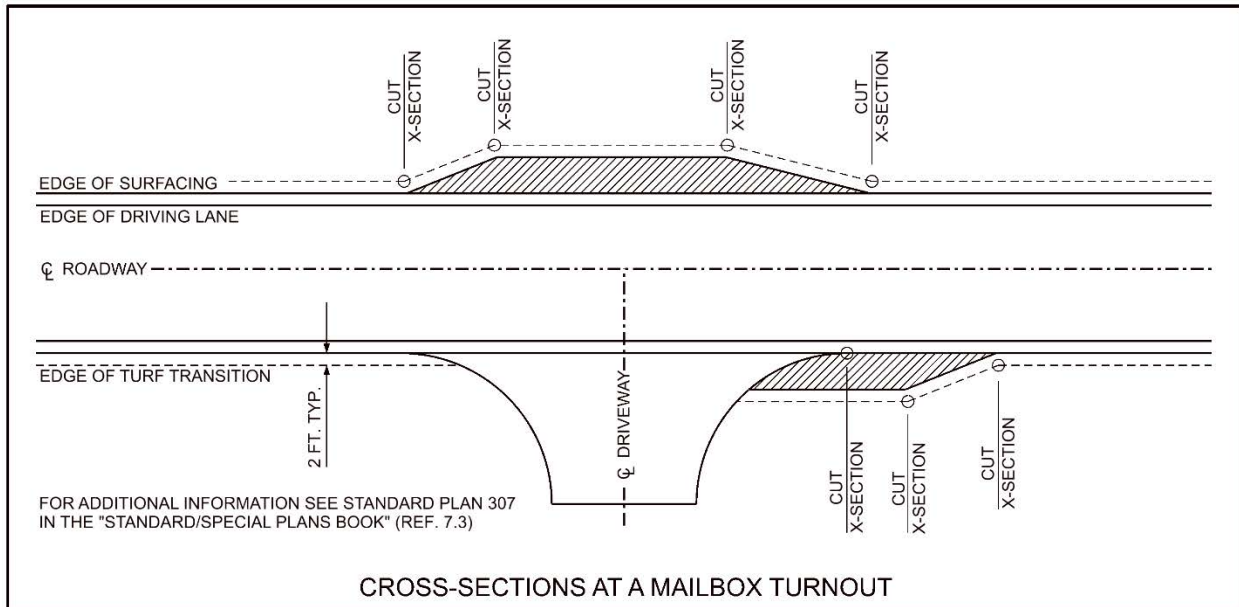
#### 3.C Contaminated Soils

See Chapter Thirteen: Planning and Project Development, Section 5.H.3, of this manual.

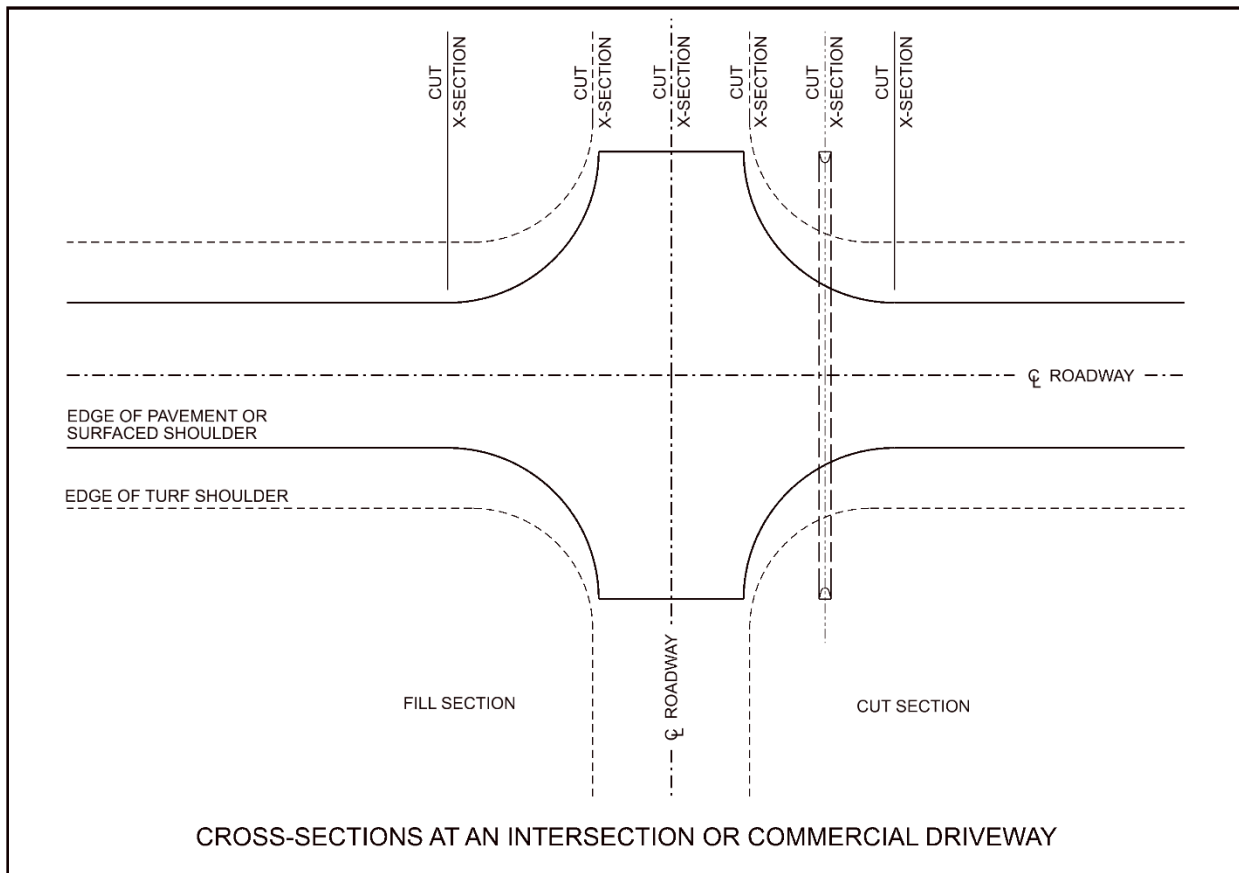
### 3.D Need for Additional Cross-Sections

Additional embankment and grading may be required at such locations as at the installation of guardrail or at mailbox turnouts. This earthwork will be calculated and included in the roadway earthwork quantities. There are also locations where the embankment and grading will not be included in the roadway quantities, such as railroad crossings and bridge exceptions. Additional cross-sections at these locations not only improve the earthwork calculations but further define the project L.O.C.s. Locations where additional cross-sections may be warranted include, but are not limited to:

- **Guardrail Grading:** At the break sections of the grading; for additional information see the guardrail grading details shown on plans 1700, 1710, and 1711 in the “Design Guides” section of the Standard/Special Plans Book (*Standard Plans*) (Ref. 7.3) (<https://dot.nebraska.gov/business-center/design-consultant/stand-spec-manual/>)
- **Mailbox Turnouts:** At the break sections of the grading (See EXHIBIT 7.5)
- **Intersections and Commercial Driveways:** At the edge of the earth shoulders for the side streets, the centerline of the intersection, and at the intersection returns on the mainline (See EXHIBIT 7.6)
- **Culverts and Culvert Extensions:** Down the flow line of the culvert
- **Special Ditches:** At the beginning and end stations and at any changes in ditch grade
- **Bridge Exceptions:** At the centerline of the bridge abutments (mainline earthwork will not be computed between the abutments)
- **Railroad Crossing Exceptions:** At the railroad crossing surfacing (earthwork will not be computed at the railroad crossing, see Chapter Ten: Miscellaneous Design Issues, Section 1.A, of this manual)
- **Survey Transitions:** At a break in the survey or the juncture of two surveys
- **Changes in terrain:** Where the grading transitions from cut to fill or visa-versa
- **Curves:** The PC and PT of non-superelevated curves and at the normal crown, adverse crown removed, reverse crown, and full superelevation sections of superelevated curves



**Exhibit 7.5 Additional Cross-Sections at a Mailbox Turnout**



**Exhibit 7.6 Additional Cross-Sections at an Intersection or Commercial Driveway**

### 3.E Shear Lines

Shear lines are used for calculating earthwork volumes at intersections where side road alignments connect with the mainline alignment and at interchanges with ramps. Earthwork volumes are calculated along the mainline to a set distance from the centerline, assuming that the earthwork has a vertical line at that location (See EXHIBIT 7.7). Earthwork is then computed for the area outside of the shear line along the side road or ramp alignment. Shear lines may also be used at other locations where irregular excavations or embankments may be caused by channel changes, access roads, etc.

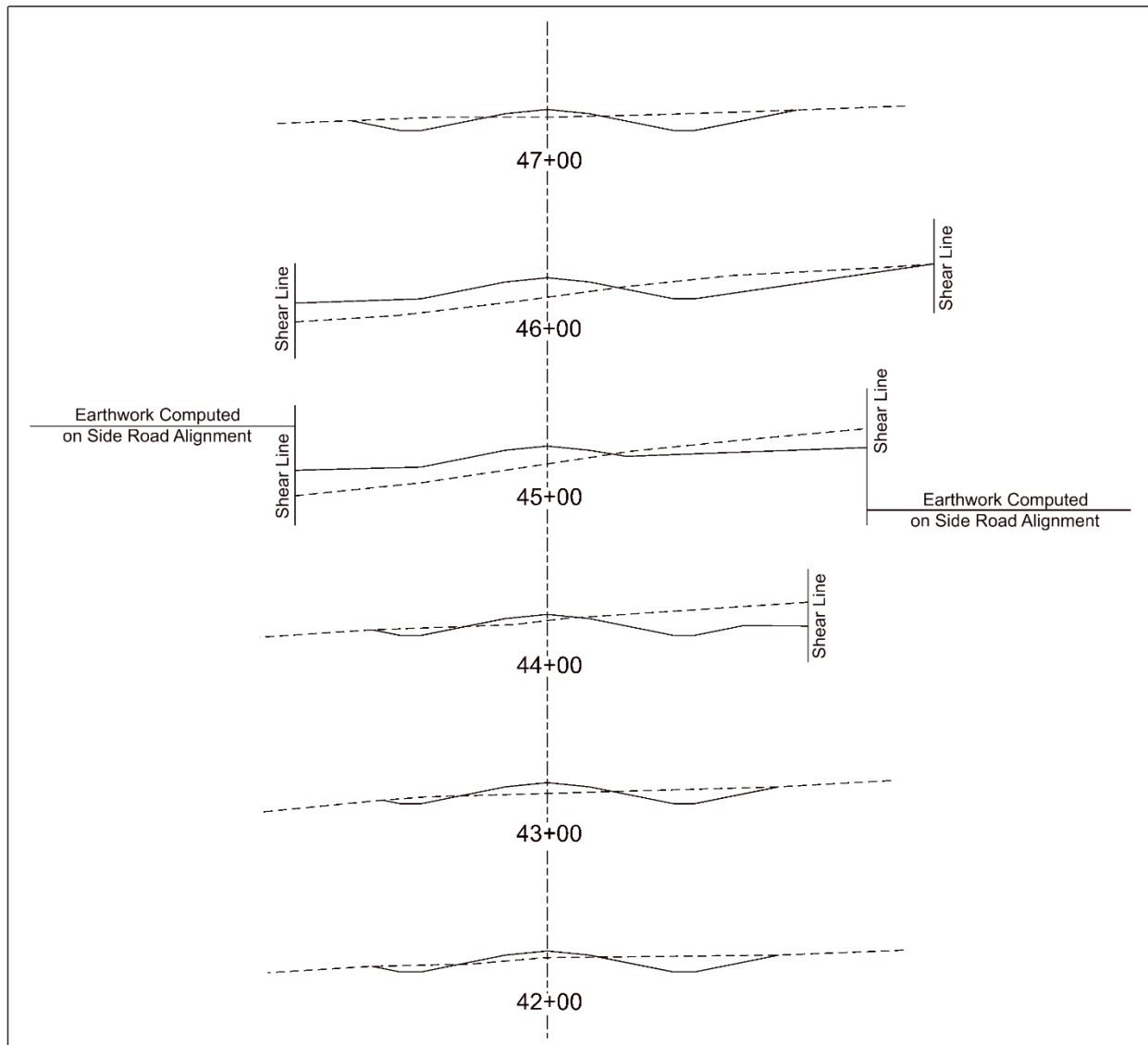


Exhibit 7.7a Shear Lines (Cross-Section)

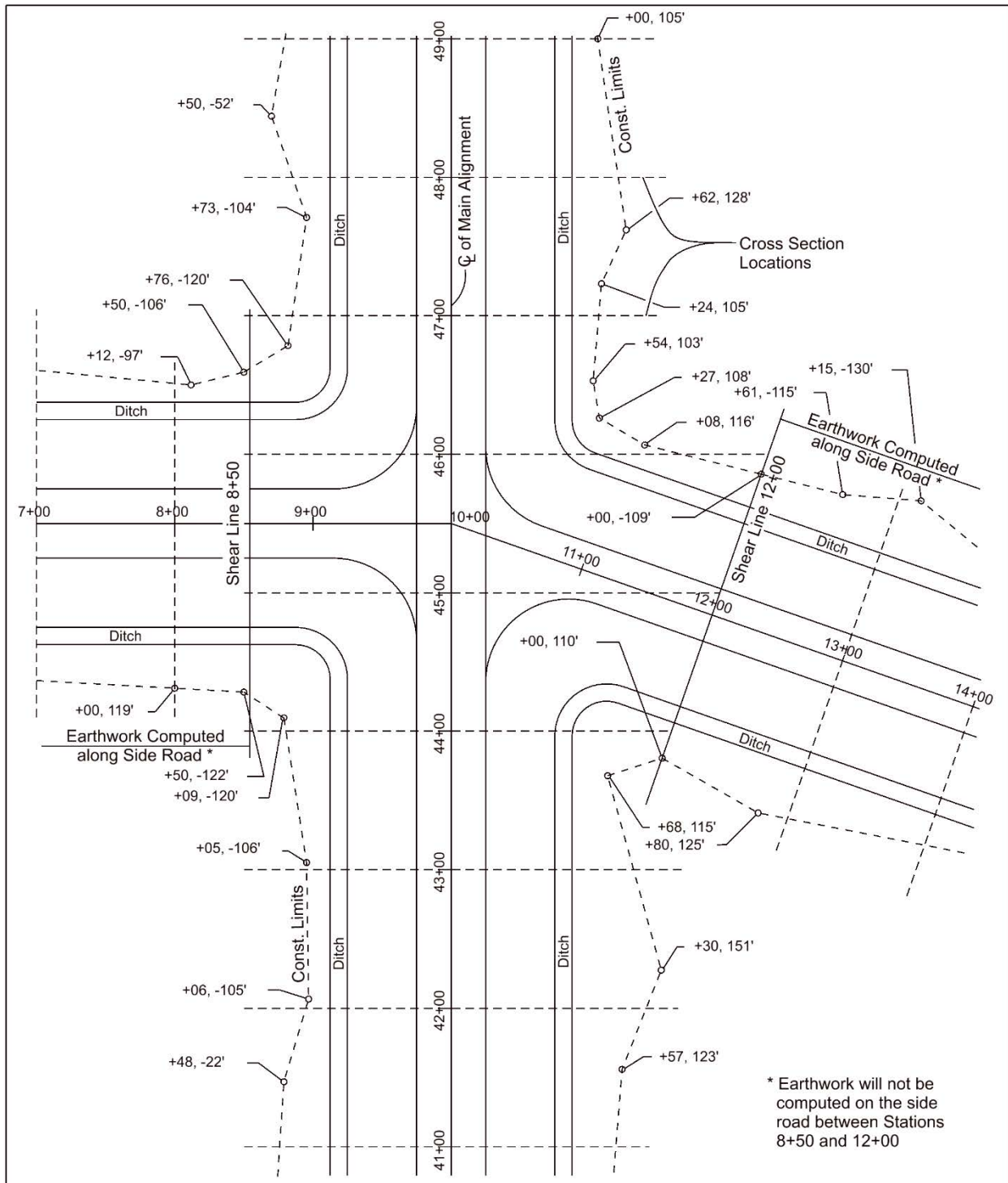
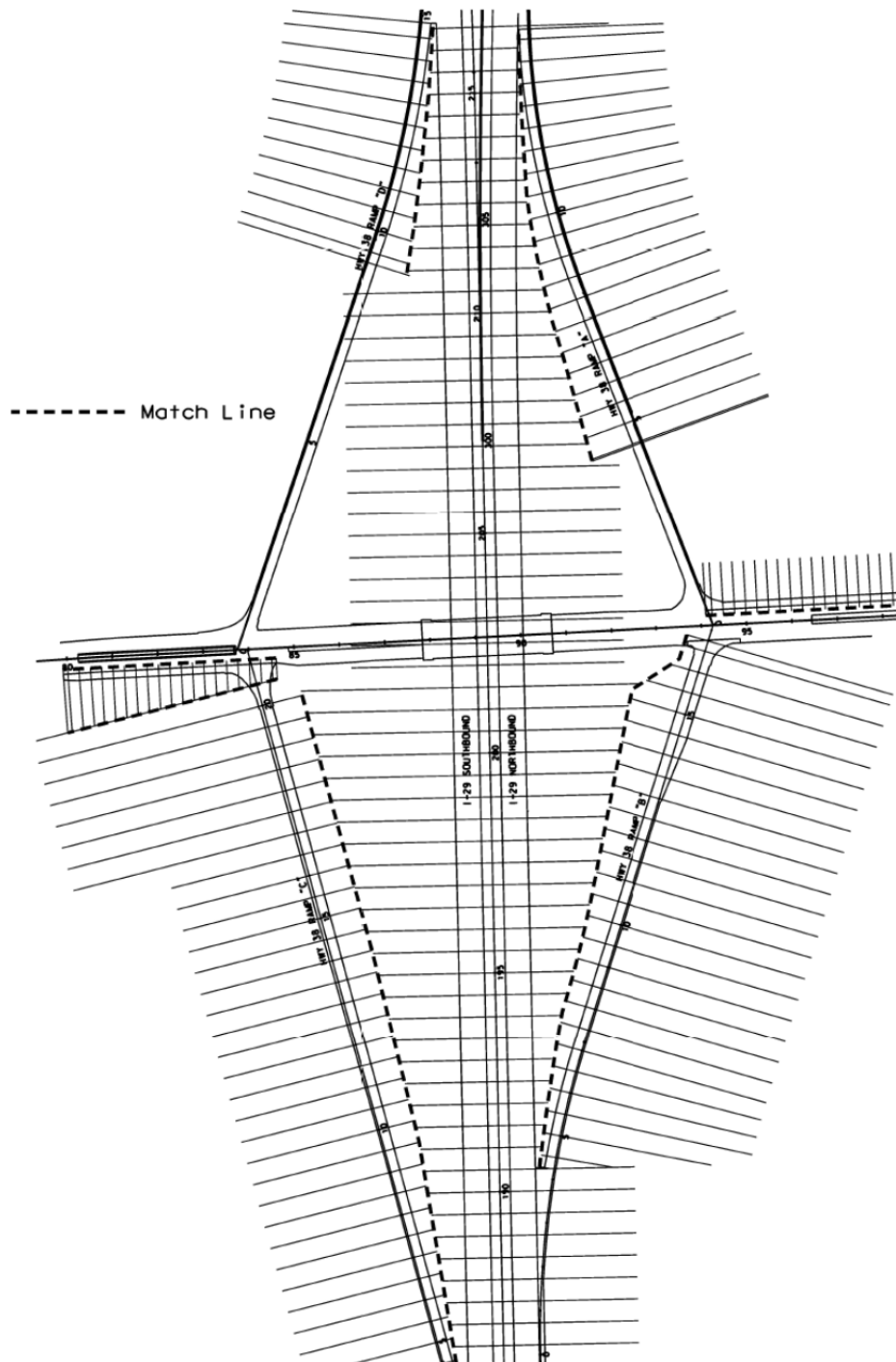


Exhibit 7.7b Shear Lines at an Intersection (Plan)



**Exhibit 7.7c Shear Lines at an Interchange (Plan)**  
**(Source: South Dakota Road Design Manual)**

#### 4. METHODS OF PAYMENT

For additional information, see the *Spec Book* (Ref. 7.1).

##### 4.A “Excavation” and “Excavation-Borrow”

“Excavation” and “Excavation-Borrow” are the preferred methods of earthwork payment on projects with large quantities, generally grading projects which average *more than* 5,000 cu. yds. per mile. On major grading projects where the earthwork is paid for as “Excavation” and where borrow must be furnished, the excavation quantity within the right-of-way and the easements will be calculated separately from the borrow. A separate pay item, “Excavation-Borrow”, will be used for the borrow. The quantities for these pay items will be measured in the field and then calculated for payment.

##### 4.B “Established Quantities”

Sometimes it is difficult to determine in the field the quantity of earthwork performed. In these situations, the earthwork should be paid for as an “Established Quantity”, which is determined by **Roadway Design** from the cross-sections. “Established Quantity” may be used for either excavation or embankment. This method of payment is most often used for urban roadway projects, for rural projects with low volumes of earthwork, and for temporary roadways. Point projects and projects with *less than* 5,000 cu. yd. of excavation or embankment per mile should be paid for as “Established Quantity”. In the Omaha area and on urban projects where the contractor will be required to furnish borrow the earthwork pay item will be an “Established Quantity”, with no separate pay item for contractor furnished borrow.

##### 4.B.1 **“Earthwork Measured in Embankment” and “Excavation (Established Quantity)”**

“Earthwork Measured in Embankment” is typically used on projects that have embankment only or on projects that are mostly embankment with very little excavation (more fill than cut) or on minor or miscellaneous projects. “Earthwork Measured in Embankment” is paid for according to the embankment measured from the cross-sections. It does not include excavation nor is it adjusted by a balance factor. When earthwork is measured in embankment and there is a substantial anticipated settlement, consideration should be given to furnishing soil information or allowing additional quantities for the settlement. On projects involving embankments constructed with granular material obtained from river borrow pits, dewatered borrow areas, etc. the earthwork should be paid for as “Earthwork Measured in Embankment”, with no separate pay item for contractor-furnished borrow.

“Excavation (Established Quantity)” (more cut than fill) is paid for according to the measured excavation from the cross-sections. A balance factor is included if there is calculated embankment.



#### 4.C Roadway Grading

For roadways constructed with only a typical section and without survey, the appropriate pay item is "Roadway Grading". "Roadway Grading" consists of the furnishing, excavating, loading, hauling, placing, compacting, and finishing of the materials necessary for the completion of the roadway, including its embankments, intersections, driveways, and approaches as shown on the plans. For further information, see the *Spec Book* (Ref. 7.1), Section 206.

#### 4.D Driveways and Field Entrances

Earthwork required for driveway and field entrance construction will be handled according to the pay item, as shown below:

1. **"Excavation" or "Excavation-Borrow"**: The designer *will not* calculate the earthwork required to build small driveways (i.e. a driveway that does not require the creation of a profile and/or is not commercial-size) and field entrances; the contractor will be paid for additional excavation as it is measured on the project.
2. **"Earthwork Measured in Embankment" or "Excavation (Established Quantity)"**: The earthwork required to build small driveways and field entrances will be included in the earthwork quantities.

#### 4.E Subsidiary Earthwork

Subsidiary earthwork is earthwork that is not paid for directly but is included in other earthwork or other construction items, such as:

- On small urban projects (e.g. curb ramps, rebuild curb, build sidewalk/multi-use trail) with small amounts of earthwork, earthwork is made subsidiary. A special provision may be required.
- The construction of small earth dikes is subsidiary to the pay item "Excavation".
- Earthwork for the construction of larger earth dikes should be calculated as "Earthwork Measured in Embankment" where no balance factor is considered, or they may be built as roadway embankment from a borrow pit, which will be paid for as "Excavation Borrow".

**5. EXAMPLE CALCULATIONS**

In this section different situations are described related to computing embankment and excavation quantities for highway projects. [EXHIBIT 7.8](#) summarizes the grading items for the examples.

Types of Quantities	Case 1 Embankment (Fill Only)	Case 2 Unbalanced - Mostly Embankment	Case 3 Balanced - Considerable Borrow	Case 4 Balanced - No Borrow	Case 5A Urban - More Excavation than Embank.	Case 5B Rural - More Excavation than Embank.
Excavation			31,830 cy	176,415 cy		
Excavation- Borrow			144,585 cy			
Excavation (Established Quantity)					10,000 cy	3,889 cy
Earthwork Measured in Embankment	38,110 cy	11,915 cy				
Water Applied, Mgal.	743	161	4,410	4,410	44	8

**Exhibit 7.8 Example Grading Pay Items**

<b>ADDITIONAL REQUIREMENTS FOR EARTHWORK CALCULATIONS</b>
ITEM 1: If an informational sheet is supplied with the plans showing a borrow pit where the contractor can obtain the embankment (optional or required pit), cross-sections should be provided showing the desired drainage and the computations made to reflect the available quantity.
ITEM 2: When earthwork is measured in embankment and there is a substantial anticipated subsidence, consideration should be given to furnishing soil information or allowing additional quantities for settlement such as surcharge on top of the fill.
ITEM 3: On projects involving embankments constructed with granular material obtained from river borrow pits, dewatered borrow areas, etc., whether borrow is state- or contractor- furnished, the earthwork should also be paid as "Earthwork Measured in Embankment." No separate pay item is required for contractor-furnished borrow.
ITEM 4: Post construction cross-sections will be taken and the excavation to be paid for will be the material actually removed, measured by volume in its original position.
ITEM 5: Pre- and post-construction cross-sections will be taken on borrow pits to determine the actual quantity of borrow.
ITEM 6: Balance points should be shown on the Plan and Profile Sheets or the General Information Sheets.
ITEM 7: Post-construction cross-sections will not be taken; the contractor will only be paid for the quantity that is shown in the plans. No balance factor will ever be applied for "Earthwork Measured in Embankment" but will be applied for "Excavation (Established Quantity)".
ITEM 8: The volume of existing concrete/asphalt pavement removal will be considered in all earthwork computations. See Section 1.C of this chapter for discussion of removal of existing surfacing.
ITEM 9: On a project where the earthwork is measured in embankment, the earthwork for the construction of driveways and field entrances must be included in the earthwork totals.

**Exhibit 7.9 Additional Requirements for Earthwork Calculations**

**5.A Case 1: Embankment (Fill) Only**

Many bridge and shoulder widening projects have only a fill quantity. No excavation is required for the roadway. Borrow will be required.

Given: An existing rural two-lane highway with six foot shoulders on level terrain in Buffalo County is to be improved to a two-lane highway with 10 foot shoulders for five miles. The highway is in fill for the full length of the project with 38,110 cu. yds. of embankment calculated. At the plan-in-hand review it was determined that the balance factor should be 1.30. Determine the earthwork quantity for payment and the amount of water needed.

Station to Station		Excavation Available (cy)	Earthwork Measured in Embankment (cy)
0 + 00	75 + 00	0	10,975
75 + 00	150 + 00	0	11,310
150 + 00	225 + 00	0	11,780
225 + 00	264 + 00	0	4,045
<b>Total</b>		0	38,110

**Exhibit 7.10 Earthwork Quantities - Case 1**

The pay items will be:

- Earthwork Measured in Embankment
- Water Applied

Solution: The earthwork quantity and pay item will be 38,110 cu. yds. of "Earthwork Measured in Embankment." It is the measured volume of embankment on the cross-sections and **is not** multiplied by the balance factor to obtain the pay item quantity, (Earthwork analysis is run at a 1.00 balance factor when paying for "Earthwork Measured in Embankment"). It is an established quantity and is not verified by field personnel after construction.

Water may be required in the compaction process to attain the proper density in the new embankment. To determine the quantity of water that needs to be applied for compaction, the measured volume of embankment must be adjusted for shrinkage by multiplying it by the balance factor since [EXHIBIT 7.3](#) is based on excavation quantities (for "Embankment", the balance factor established at the PIH will be used when calculating "Water Applied").

$$38,110 \text{ cu. yds.} \times 1.30 = 49,543 \text{ cu. yds.}$$

The quantity of water that needs to be applied is determined by multiplying the adjusted volume of embankment by the number of gallons of water per cu. yd. as indicated in [EXHIBIT 7.3](#) for the area in which the project is located. For this example, Buffalo County is in Area 3 and the project averages less than 40,000 cu. yds. of excavation per mile. The rate at which water should be applied for compaction is 15 gal. of water per cu. yd. of embankment:

$$49,543 \text{ cu. yds.} \times 15 \text{ gal./cu. yd.} = 743,145 \text{ gal. (call 743 Mgal.) (1 Mgal. equal 1000 gallons).}$$

According to the specifications, the contractor is paid for the quantity of “Earthwork Measured in Embankment” as shown on the plans (38,110 cu. yds.) and the quantity of “Water Applied” in Mgal. (743 Mgal.).

The following standard note should be shown on the plans:

STANDARD NOTE 12  
 THE CONTRACTOR WILL BE REQUIRED TO FURNISH BORROW.

EXHIBIT 7.10 shows a typical earthwork table that should be included on the plans. See items 2, 3, 7 and 8 in EXHIBIT 7.9 for additional information pertaining to this example.

**5.B Case 2: Unbalanced - Mostly Embankment**

Some major projects have the majority of the earthwork in fill and just a small cut quantity. This may occur on projects that involve adding a lane to an existing road.

Given: An existing rural two-lane highway on mostly level terrain in Madison County is to be improved to a four-lane highway with a median. The project begins at Sta. 1+00 and ends at Sta. 72+89. There is a major crossroad at Sta. 27+32, a stream crossing at Sta. 57+15, and the city limits at Sta. 68+40. At the plan-in-hand review it was determined that the balance factor should be 1.35.

Given the earthwork quantities in EXHIBIT 7.11, determine balance points for distribution analysis, the earthwork quantities for payment and the amount of water needed.

The pay items will be:

- Earthwork Measured in Embankment
- Water Applied

Solution: For this example, balance points should be at the following locations:

- Sta. 27+32 - cross road
- Sta. 57+15 - stream crossing
- Sta. 68+40 - city limits.

Since these balance points occur at intervals of approximately 0.5 mile, no intermediate balance points are needed.

Station to Station	Excavation Available (cy)	Earthwork Measured in Embankment (cy)
1+00      27+32	1,050	3,520
27+32    57+15	500	5,340
57+15    68+40	0	2,640
68+40    72+89	0	415
<b>Total</b>	1,550	11,915

**Exhibit 7.11 Earthwork Quantities - Case 2**

The pay item will be 11,915 cu. yds. of "Earthwork Measured in Embankment" of which 1,550 cu. yds. will be excavated as shown on cross-sections (See Case 1, which explains "Earthwork Measured in Embankment" in greater detail).

For the amount of water that needs to be applied for compaction, the embankment quantity needs to be adjusted for shrinkage by multiplying it by the balance factor:

$$11,915 \text{ cu. yds.} \times 1.35 = 16,085 \text{ cu. yds.}$$

The quantity of water that needs to be applied is determined by multiplying the adjusted volume of embankment by the number of gallons of water per cu. yd. as indicated in [EXHIBIT 7.3](#) for the area in which the project is located. For this example, Madison County is in Area 2 and the project averages less than 40,000 cu. yds. per mile of excavation. The rate at which water should be applied for compaction is 10 gallons of water per cu. yd. of embankment:

$$16,085 \text{ cu. yds.} \times 10 \text{ gal./cu. yd.} = 160,850 \text{ gal. (call 161 Mgal.)}$$

In this case, the following standard note should be shown on the plans:

STANDARD NOTE 12  
THE CONTRACTOR WILL BE REQUIRED TO FURNISH BORROW.

[EXHIBIT 7.11](#) shows an example of an earthwork table that should be included on the plans. See items 2, 3, 7 and 8 in [EXHIBIT 7.9](#) for additional information pertaining to this example.

### **5.B.1 Case 2A: More Embankment than Excavation in Urban Areas**

Use the procedures outlined in Section 5.B above.

### **5.C Case 3: Considerable Borrow**

Often on major grading projects, such as adding lanes to an existing highway, the earthwork is paid as excavation even though a considerable amount of borrow is required to complete the project.

Given: An existing two-lane highway in Cheyenne County is to be widened to a four-lane highway. The project begins at Sta. 100+00 and ends at Sta. 497+00. There is a side road at Sta. 363+00 and improvements along the side road run from Sta. 3001+00 to Sta. 3077+00. There are no other side road crossings or major stream crossings. At the plan-in-hand inspection it was determined that the balance factor should be 1.45. Given the earthwork quantities in [EXHIBIT 7.12](#) (Excavation = 31,830 cu. yd., Embankment = 121,665 cu. yd.), determine the balance points for the distribution analysis, the earthwork quantities for payment, and the amount of water needed.

The pay items will be:

- Excavation
- Excavation Borrow
- Water Applied

Solution: For this example, balance points should be at the location of the side road and approximately every mile between the start and the side road and between the side road and the end:

- Sta. 152+00
- Sta. 204+00
- Sta. 257+00
- Sta. 310+00
- Sta. 363+00 - side road
- Sta. 416+00
- Sta. 467+00

1. The measured excavation is 31,830 cu. yds. and will be paid for as "Excavation".
2. Since there is more embankment than excavation available, borrow is necessary and is calculated by subtracting the excavation from the adjusted embankment. For the adjusted embankment volume, multiply the measured embankment by the balance factor:

$121,665 \text{ cu. yds.} \times 1.45 = 176,415 \text{ cu. yds.}$

Then subtract the measured excavation from the adjusted embankment:

$176,415 \text{ cu. yds.} - 31,830 \text{ cu. yds.} = 144,585 \text{ cu. yds.}$

The quantity and pay item will be 144,585 cu. yds. of "Excavation-Borrow."

The quantity of water that needs to be applied is determined by multiplying the adjusted volume of embankment by the number of gallons of water per cu. yd. as indicated by [EXHIBIT 7.3](#) for the area the project is located. For this example, Cheyenne County is in Area 4 and the project averages less than 40,000 cu. yds. of excavation per mile. The rate at which water should be applied for compaction is 25 gal./cu. yd. of embankment:

$176,415 \text{ cu. yds.} \times 25 \text{ gal./cu. yd.} = 4,410,375 \text{ gal. (call 4,410 Mgal.)}$

In this situation post-construction roadway cross-sections will be taken and the excavation to be paid for will be the material actually removed, measured by the cu. yd., in its original position. Also pre- and post-construction cross-sections will be taken on the borrow pit to determine the actual quantity of borrow used. Pay items in Case 3 will be "Excavation" and "Excavation Borrow."

The standard note that should appear on the plans for this situation is:

STANDARD NOTE 12  
THE CONTRACTOR WILL BE REQUIRED TO FURNISH BORROW.

[EXHIBIT 7.12](#) shows an example of an earthwork table that should be included on the plans. See items 1, 4, 5, 6 and 8 in [EXHIBIT 7.9](#) for additional information pertaining to this example situation.

Earthwork					
Station to Station		Excavation (cy)	Excavation - Borrow (cy)	Embankment (cy)	Balance Factor
100+00	152+00	745	11,405	8,380	1.45
152+00	204+00	1,635	20,775	15,455	1.45
204+00	257+00	495	16,870	11,975	1.45
257+00	310+00	2,275	14,420	11,515	1.45
310+00	363+00	8,345	24,085	22,365	1.45
363+00	416+00	3,710	22,940	18,380	1.45
416+00	467+00	13,155	17,750	21,315	1.45
467+00	497+00	1,455	12,670	9,740	1.45
3001+00	3077+00	15	3,670	2,540	1.45
<b>Total</b>		31,830	144,585	121,665	

**Exhibit 7.12 Earthwork Quantities - Case 3**

**5.D Case 4: Balanced - No Borrow**

A balanced project with no borrow occurs when the material excavated from within the limits of the section is sufficient to construct embankments to the designed grade.

Given: The same existing highway, improvements and conditions as in Case 3 except that the earthwork quantities are those shown in EXHIBIT 7.13, determine the earthwork quantities and pay items.

Earthwork					
Station to Station		Excavation (cy)	Embankment (cy)	Balance Factor	
100+00	152+00	12,150	8,380	1.45	
152+00	204+00	22,410	15,455	1.45	
204+00	257+00	17,365	11,975	1.45	
257+00	310+00	16,695	11,515	1.45	
310+00	363+00	32,430	22,365	1.45	
363+00	416+00	26,650	18,380	1.45	
416+00	467+00	30,905	21,315	1.45	
467+00	497+00	14,125	9,740	1.45	
3001+00	3077+00	3,685	2,540	1.45	
<b>Total</b>		176,415	121,665		

**Exhibit 7.13 Earthwork Quantities - Case 4**

The pay items will be:

- Excavation
- Water Applied

Solution: Adjust the embankment volume for shrinkage by multiplying it by the balance factor:

$$121,665 \text{ cu. yds.} \times 1.45 = 176,415 \text{ cu. yds.}$$

Since the adjusted embankment volume is equal to the measured excavation quantity, the earthwork is balanced, additional excavation is not needed and no borrow is required; therefore, the only earthwork quantity and pay item will be 176,415 cu. yds. of "Excavation." The quantity of "Water Applied" in this example is 4,410 Mgal., similar to the quantities calculated in case 3.

The standard note that should appear on the plans for this situation is:

STANDARD NOTE 13  
 THE CONTRACTOR WILL NOT BE REQUIRED TO FURNISH BORROW.

EXHIBIT 7.13 shows an example of an earthwork table that should be included on the plans. See items 4, 6, and 8 in EXHIBIT 7.9 for additional information pertaining to this example.

It should be noted that balance points for this example were shown at one-mile stations for simplicity. For actual projects, the designer should refer to the mass ordinate in the distribution analysis to determine locations of natural balances (See Section 1.A.2 of this chapter).

**5.E Case 5: Excavation or Embankment in Urban Areas and on Rural Projects with Low Volumes of Earthwork**

**5.E.1 Case 5A: More Excavation than Embankment in Urban Areas**

In urban areas, where it is often difficult to determine the quantity of earthwork performed because of curb/gutter and driveways, the earthwork will be paid for as "Excavation (Established Quantity)" or "Earthwork Measured in Embankment." For additional information see Section 4.B of this chapter.

Given: An existing four-lane urban highway is being widened to six lanes in Douglas County. The project begins at Sta. 1+00 and ends at Sta. 55+00. At the plan-in-hand inspection it was determined that the balance factor should be 1.45. Given the information in EXHIBIT 7.14, determine earthwork quantities, pay items and the water that should be applied.

Station to Station	Balance Factor	Excavation (Established Quantity) (cy)	Embankment (cy)	Waste (cy)
1+00 55+00	1.45	10,000	3,000	5,650
<b>Total</b>		10,000	3,000	5,650

**Exhibit 7.14 Earthwork Quantities - Case 5A**

The pay items will be:

- Excavation (Established Quantity)
- Water Applied



Solution: For the adjusted embankment, multiply the measured embankment by the balance factor:

$$3,000 \text{ cu. yds.} \times 1.45 = 4,350 \text{ cu. yds.}$$

Since the adjusted embankment is less than the measured excavation, the quantity and pay item will be 10,000 cu. yds. of "Excavation (Established Quantity)." There will be no cross-sections taken in the field to verify this quantity. There will be waste, the amount of which will be determined by subtracting the adjusted embankment from the excavation:

$$10,000 \text{ cu. yds.} - 4,350 \text{ cu. yds.} = 5,650 \text{ cu. yds. of waste.}$$

The quantity of water that needs to be applied is determined by multiplying the adjusted volume of embankment by the number of gallons of water per cu. yd. as indicated in [EXHIBIT 7.3](#) for the area in which the project is located. For this example, Douglas County is in Area 2 and the project averages less than 40,000 cu. yds. of excavation per mile. The rate at which water should be applied for compaction is 10 gallons of water per cu. yd. of embankment:

$$4,350 \text{ cu. yds.} \times 10 \text{ gal./cu. yd.} = 43,500 \text{ gal. (call 44 Mgal.)}$$

The following notes should be shown on the plans:

STANDARD NOTE 13  
THE CONTRACTOR WILL NOT BE REQUIRED TO FURNISH BORROW.

STANDARD NOTE 14  
THE CONTRACTOR WILL BE REQUIRED TO FURNISH WASTE AREAS FOR EXCESS.

See item 8 in [EXHIBIT 7.9](#) for additional information pertaining to this example.

### **5.E.2 Case 5B: More Excavation than Embankment on a Rural Project with Low Volumes of Earthwork**

On some rural projects with low volumes of earthwork it is desirable to use an established quantity pay item, either "Earthwork Measured in Embankment", or "Excavation Established Quantity". For additional information see Section 4.B of this chapter.

Given: An existing bridge on a two-lane rural roadway in Pawnee county is being removed and replaced. The new bridge will be approximately one-foot lower than the old bridge and the roadway profile will be lowered to match the new bridge. The project begins at Sta. 102+00 and ends at Sta. 110+40. At the plan-in-hand inspection it was determined that the balance factor should be 1.40. Given the information in [EXHIBIT 7.15](#), determine earthwork quantities, pay items and the water that should be applied.

Station To Station	Balance Factor	Excavation (Established Quantity) (cy)	Embankment (cy)	Waste (cy)
102+00 110+40	1.4	3,889	1,159	2,266
<b>Total</b>	1.4	3,889	1,159	2,266

**Exhibit 7.15 Earthwork Quantities – Case 5B**

The pay items will be:

- Excavation (Established Quantity)
- Water Applied

Solution: For the adjusted embankment, multiply the measured embankment by the balance factor:

$$1,159 \text{ cu. yds.} \times 1.40 = 1,623 \text{ cu. yds.}$$

Since the adjusted embankment is less than the measured excavation, the quantity and pay item will be 3,889 cu. yds. of "Excavation (Established Quantity)." There will be no cross sections taken in the field to verify this quantity. There will be waste, the amount of which will be determined by subtracting the adjusted embankment from the excavation:

$$3,889 \text{ cu. yds.} - 1,623 \text{ cu. yds.} = 2,266 \text{ cu. yds. of waste.}$$

The quantity of water that needs to be applied is determined by multiplying the adjusted volume of embankment by the number of gallons of water per cu. yd. as indicated in [EXHIBIT 7.3](#) for the area in which the project is located. For this example, Pawnee Country is in Area 1 and the project averages less than 40,000 cu. yds. of excavation per mile. The rate at which water should be applied for compaction is 5 gallons of water per cu. yd. of embankment.

$$1,623 \text{ cu. yds.} \times 5 \text{ gal./cu. yd.} = 8,115 \text{ gal (call 8 Mgal)}$$

The following notes should be shown on the plans:

STANDARD NOTE 13  
 THE CONTRACTOR WILL NOT BE REQUIRED TO FURNISH BORROW.

STANDARD NOTE 14  
 THE CONTRACTOR WILL BE REQUIRED TO FURNISH WASTE AREAS FOR EXCESS.

See item 8 in [EXHIBIT 7.9](#) for additional information pertaining to this example.

## 6. REVIEWING EARTHWORK COMPUTATIONS AND CROSS-SECTIONS

The following checks should be made on the earthwork computations and roadway cross-sections:

- **Design Phase (Activity 5300):** The **Roadway Design Unit Head (Unit Head)** should review the earthwork checklist with the roadway designer
- **Environmental Approval Phase (Activity 5400):** The **Unit Head** and designer should review the earthwork checklist and note changes from the plan-in-hand plans
- **Plan Details Phase (Activity 5500):** The **Unit Head** and designer should check the earthwork and cross-sections before transmitting plans to **ROW**
- **Plan Package Phase (Activity 5700):** The **Unit Head** and the designer should check:
  1. The computer generated earthwork output.
  2. The earthwork data sheets.
  3. The final cross-sections.
- **Begin Construction Phase (Activity 5900):** the designer should check the field books

See [EXHIBIT 7.16](#) for the Earthwork Checklist.

## 7. FINALIZING ROADWAY EARTHWORK FOR PAYMENT

After the project is completed, the **District** will perform a final surface shots survey. The final surface shots are sent to the **Final Review Section in Construction**, who will request that the survey be loaded into GeoPak, along with the preliminary project survey. Once this has been accomplished, the **Final Review Section** will inform the **Roadway Design Support Units ADE** that the GeoPak file is available. The **Support Units ADE** will assign a designer to calculate the roadway earthwork quantities based on whether the project was in-house or a consultant project and designer availability (the cross-sections for final earthwork computations should be cut at the same locations as the project design). When the final earthwork computations are finished, the designer will send them to the **Final Review Section in Construction**. These computations should be accomplished in a timely manner, they are necessary to close out the project and to make final payment to the contractor.

**Existing Surfacing** - Will it be removed, salvaged, or incorporated in the fill? Check with **M&R** and the **DCE** about payment for stockpiling and salvaging.

**Undercut (Determination of Subgrade Elevation)** - Account for surfacing, foundation course or soil aggregate base course. Compensate for shoulder material if necessary.

**Balance Factor** - Verify with **DE** or **PIH** report. Try to balance every mile.

**Subgrade Slope on Shoulders** - Same slope as driving lanes on full grading projects.

**Subgrade on Superelevated Section** - Verify against appropriate standard plan. Does the shoulder have a maximum 7% rollover?

**Transitions to Superelevation** - Does the roadway and shoulder superelevate properly - check transition distances.

**Design Exceptions at Bridges** - Does earthwork taper from abutment to flow line as designed by the bridge designer?

**Roadway Cross-Sections** - Are the slope break points at the appropriate locations?

**Special Ditches** – Shown on P&P sheets? When the ditch bottom is lower than the normal hinge point, verify that the 1:6 foreslope continues to the hinge point, and then breaks to a 1:4 or 1:3 at the required distance from centerline.

**Intersections & Driveways** - 1:6 transverse slopes within the clear zone? Do the foreslopes correspond to the criteria shown in the Typical X-Sections (*Standard Plans*, Ref. 7.3) “Rural Intersections and Driveways”). Pipe lengths match driveway slopes?

**Guardrail Locations** - Shoulder slope continued to two feet behind the surfacing and five feet beyond the last post. Transition the earthwork behind the guardrail from foreslope to bridge design.

**Dikes** - Are intercepting dikes shown on the cross-sections and sloped at 1:6 facing traffic within the clear zone, 1:10 within a median? (Normally, embankment required for a dike is not multiplied by the balance factor).

**Phasing** – Show on cross-sections and earthwork for each phase.

**Temporary Drainage** – Check drainage for each phase.

**Detours, Temporary Roads** - Will grading for temporary roads or detours be required?

**Borrow/Waste Areas** - Are these areas to be delineated or is it the contractor’s responsibility if borrow is along the project.

**Channel Changes** - Determine if excavation should be included with the total excavation or split out as “channel excavation”; this is determined on a case-by-case basis.

**Surcharges/Settlement** - Check with **M&R Geotechnical Engineer**.

**Shoulder Construction/Urban Areas** - Do the cross-sections show the shoulder construction according to policy?

**Exhibit 7.16 Earthwork Checklist**

## 8. SOIL, SUBGRADE, AND SITUATION REPORTS

The soil, subgrade, and materials surveys prepared by **M&R** provide pertinent information to be used in the following aspects of highway design:

- Location of the grade line, both vertically and horizontally
- Location and selection of borrow material for fills and subgrade treatment
- Design and location of ditches and underdrains
- Design of the roadway section
- Need for subgrade treatment and type of treatment required
- Location of local sources of construction material
- Selection of the surfacing type and its design (See Chapter Eight: Surfacing, Section 1, of this manual)

### 8.A Soil Survey/Soil and Situation Report

#### 8.A.1 Soil Survey

A soil survey is usually performed with the Roadway Design plans (Clarity Task 5350). The survey usually consists of the research of soils maps, aerial photographs, geology reports and condition reports, preliminary field reconnaissance of the project, previous project reports, soil borings in areas of excavation and embankment, and recordings of water table locations. Laboratory soil tests are made on the samples taken and results are tabulated.

The soil survey will research the soil profile, soil horizons and the uniformity of the profile throughout the project, soil compaction and other soils characteristics by station, the water table condition, and other concerns such as underground wet zones. **M&R** uses the following criteria to determine the minimum finished grade elevation above the expected high water table:

- Four feet above the expected high water table if the entire profile is sand
- Seven feet above the expected high water table if there is to be silt-clay within four feet of the finished grade elevation

#### 8.A.2 Preliminary Soil and Situation Report

If the soil survey reveals a condition that may present problems for the design or construction of a project, a Preliminary Soils and Situation Report is submitted to the **Roadway Design Division**. The preliminary report usually addresses water table concerns. It may include locations of usable quantities of sand in a silt-clay region or locations of borrow pits. Settlement and unsuitable material issues may also be addressed. Unless there is a big cut or fill, a preliminary report is not normally sent to **Roadway Design**.

### 8.A.3 Soil and Situation Report

The Soil and Situation Report presents the results of the soil survey in a standardized format. It includes the following:

- The location and length of the project
- The topography and drainage situation
- The water table
- The geology of the project area
- Soil horizons and formations
- Soil descriptions, including engineering characteristics
- Recommendations for subgrade treatments
- Compaction requirements

If selective handling of excavated materials is planned for the project, recommendations for the handling are also included. Selective handling is generally restricted to five cases:

1. To produce embankment sections of uniform material (e.g. all silt-clay soils or all sandy materials in the upper embankment)
2. To place materials suitable for use in a bituminous sand base course in the upper subgrade
3. To place highly undesirable materials at depth or in the outer slopes of the embankment
4. To place select materials over heavy clay materials to reduce moisture problems
5. To use select granular materials in lieu of a foundation course on Portland cement concrete pavement projects

The Soil and Situation Report will divide the project, if necessary, into sections of one or more balances according to soil type or other factors. A detailed discussion of soil materials to be excavated is then developed for each section. The selective soil placement notes reflect the surfacing plans for the project. The soil survey may also identify locations for possible sources of shoulder material, topsoil to support subsequent vegetation or soil binder material. It is the responsibility of the designer to verify that the recommendations of the Soil and Situation Report, and the resulting design, are detailed on the project plan sheets.

## 8.B Subgrade Survey/Subgrade and Situation Report

### 8.B.1 Subgrade Survey

The subgrade survey is conducted on previously graded roads for which rigid or flexible pavement is being designed. Its principal objectives are:

- To sectionalize the project according to the type of soil in the upper subgrade
- To locate and explore portions of the project where the subgrade may be of questionable stability due to springs, seepage or wet zones
- To evaluate gravel windrow or crust which may have been placed or developed under traffic with temporary gravel surfacing or clay surfacing
- To obtain a check on the conditions resulting from the selective placement required by the grading plans

### 8.B.2 Subgrade and Situation Report

The Subgrade and Situation Report is prepared for those projects where there is substantial time between grading and the preparation of paving plans (e.g. grading for future turn lanes). Whenever grading and paving are let in the same contract, the design of the base and surface courses is based on information obtained from the soil survey.

The Subgrade and Situation Report usually contains the following:

- A description of the existing surface conditions
- The proposed construction
- The foundation course requirements
- The existing topography and pedology
- A description of and recommendations for the surface and subsurface drainage
- Compaction requirements
- Subgrade distress
- Embankment and/or slope stability problems

The compaction requirements list will be added to the plans.

### 8.C Embankment Foundation Report

In known areas of poor foundation soils, a field investigation of foundation soils is made by the **Soils Mechanics Unit** of **M&R** to develop recommendations to minimize settlement and slope stability problems. An Embankment Foundation Report is submitted to the **Roadway Design Division** to advise of possible adverse conditions and to recommend possible remedies. The two most common solutions to correct settlement problems are:

- Construct surcharges to speed up settlement (See Section 8.C.1 of this chapter)
- Delay paving until settlement has reached a satisfactory level

Other possible corrective measures include:

- Use of temporary bituminous paving until settlement has reached a satisfactory level, when permanent paving may be placed
- Excavation of unsuitable material
- Use of vertical sand drains to speed settlement
- Lower the height of the fill
- Realign the road to avoid the unsuitable area
- Bridging over the unsuitable area

To correct embankment stability problems during and after grading construction, several possible solutions are available (See the Earthwork Engineering Guide, Ref. 7.5):

- Require special compaction of the embankment material (e.g. higher minimum density and lower maximum moisture content)
- Flatten side slopes of the embankment from 1:3 to 1:5
- Build berms
- Staged construction, the process of bringing fill up to maximum height in several stages over a period of time (usually two or more years)
- Excavate unsuitable material
- Lower the height of the fill
- Realign the road
- Bridging
- A combination of the above (e.g. special compaction and stage construction)

The recommendations contained in the Embankment Foundation Report, and the resulting design, will be detailed on the project plan sheets.

#### **8.C.1 Settlement Surcharge**

When embankment is placed on existing ground the weight of the embankment may cause the existing ground to settle and thus the embankment will also settle. An excess of embankment may be placed to overcome the effects of settlement. The Embankment Foundation Report will usually indicate when additional embankment is necessary. The designer will coordinate the design of the project in areas of embankment settlement with the **Soils Engineer** in **M&R**.



**9. REFERENCES**

- 7.1 Nebraska Department of Transportation, Standard Specifications for Highway Construction (*Spec Book*), 2017.  
(<https://dot.nebraska.gov/media/g4gp4y0d/2017-specbook.pdf>)
- 7.2 Nebraska Department of Transportation, Drainage Design and Erosion Control Manual (*Drainage Manual*), Current Edition.  
(<https://dot.nebraska.gov/business-center/design-consultant/rd-manuals/>)
- 7.3 Nebraska Department of Transportation, Standard/Special Plan Book (*Standard Plans*), Current Edition.  
(<https://dot.nebraska.gov/business-center/design-consultant/stand-spec-manual/>)
- 7.4 Nebraska Department of Transportation, Design Process Outline (*DPO*), Current Edition. (<https://dot.nebraska.gov/business-center/design-consultant/>)
- 7.5 Nebraska Department of Transportation, Earthwork Engineering Guide, 1990.



The information contained in Chapter Eight: Surfacing, dated May 2022, has been updated to reflect the October 2023 Errata. The errata incorporates DES 22-04: “Policy for the Installation of Centerline Rumble Stripes” (approved by the Nebraska Division of the FHWA on January 19, 2023), incorporates DES 23-03: “Policy for the Installation of Edgeline Rumble Stripes” (approved by the Nebraska Division of the FHWA on October 2, 2023), incorporates the Material and Research Policy MR 23-02: “Policy for Longitudinal Joints – Limit Concrete Panel Width” (approved by the NDOT Deputy Director for Operations on March 14, 2023), addresses errors, changes in procedure, changes in NDOT department titles, changes in other Roadway Design Manual chapters and other reference material citations occurring since the latest publication of this chapter.

Chapter Eight presents guidance for the design of New, Reconstructed, and 3R projects; additional design guidance for 3R projects is provided in Chapter Seventeen.

# Chapter Eight

## Surfacing

### 1. PAVEMENT DESIGN DETERMINATION

The **Materials and Research Division (M&R)** will provide pavement determinations to the **Roadway Design Division (Roadway Design)**. Pavement determinations may include:

- The type and thickness
- Whether a foundation course is required
- Type of subgrade treatment
- Type of subgrade drainage
- The shoulder treatment to be used

#### 1.A Pavement Design Input

**M&R** uses design-year traffic projections, existing pavement structure, condition of pavement, performance period, reliability, maintenance history, project type, subgrade soil types, and environmental factors (e.g. roadbed swelling and frost heave), the number of lanes, the design speed, and the shoulder treatment as input into the pavement design determination. An additional important consideration is input of problem areas from the **District Engineer (DE)**.

**M&R** uses traffic data from the **Nebraska Department of Transportation (NDOT)** “Pavement Optimization Program” for projects utilizing the existing roadway cross-section on the existing alignment. Other projects use traffic data available from the **Strategic Planning Division**.

#### 1.B Pavement Determination Development

The surfacing recommendation is developed as part of the “Project Process Initiation” (NDOT Form 73), which is routed to stakeholders, which includes the **Division Heads**, for review and comment. Once any changes to the document indicated by the routing have been approved by the **Program Management Engineer**, the **DE**, and the **Deputy Director-Engineering** an electronic copy of NDOT Form 73 will be placed in OnBase.

Changes may be made to the pavement determination throughout the life of the project as circumstances dictate (e.g. new information regarding surface condition, additional lanes). The opportunity to address these changes is included in “Planning Pavement Determination” (Clarity Task 5258), “Approved Pavement Determination” (Clarity Task 5364), and “Final Pavement Determination” (Clarity Task 5406). The documentation for any changes will be filed in OnBase by **M&R** and transmitted to **Roadway Design** for review and comment.

The “Final Pavement Determination” requires the signature of the **Pavement Design Engineer**, the **M&R Engineer**, and the **DE** prior to distribution to **Roadway Design**.

## 2. PAVEMENT TYPES

There are three types of pavement, rigid, flexible, and a composite of rigid and flexible. **M&R** recommends the pavement type and thickness.

### 2.A Rigid (Concrete) Pavement

Rigid pavement is constructed with Portland Cement Concrete (PCC). Due to the potential for water infiltration at the joints, a foundation course and a means of draining the foundation course may be included in the design of a rigid pavement.

#### 2.A.1 Portland Cement Concrete Pavement Design Policy

1. Rigid pavements will be plain jointed PCC. Epoxy coated dowel bars will be included at transverse joints.
2. The minimum pavement thickness of PCC pavement on the State Highway System will be as follows:
  - Interstate System ..... 12 inches
  - Expressway System ..... 10 inches
  - Other Highways ..... 9 inches
  - Low Volume Highways ..... 8 inches

The concrete thickness should be shown in the plan build note and on the typical roadway cross-section(s).

3. The maximum spacing for transverse joints is 16 feet - 6 inches, placed perpendicular to the centerline of the roadway (See Standard Plan 329 in the Standard/Special Plans Book (Standard Plans), Ref. 8.1) (<https://dot.nebraska.gov/business-center/design-consultant/stand-spec-manual/>).
4. See Section 2.A.2.a of this chapter for longitudinal joint spacing.
5. If PCC shoulders are built with the mainline, they will be tied to the travel lanes and the tie bars will be subsidiary to the concrete pavement. If concrete shoulders are built adjacent to an existing concrete mainline the tie bars will be a separate pay item. For additional information see the *Standard Plans*, Ref. 8.1, Standard Plan 329.

**2.A.2 Pavement Joints**

Diagrams showing the joint locations will be included in the plan set for PCC pavement; typical joint diagrams for concrete pavement are available in the *Standard Plans* (Ref. 8.1), Standard Plan 329. A joint diagram plan must be developed, however, for complicated intersections and/or lane drops. When plans call for the widening of existing surfacing and the new joints are to match the existing joints, a note to that effect on the plans will be sufficient. Ideally, joints should correspond to the pavement markings. The designer will submit the joint diagrams to the **M&R Pavement Design Engineer** and to the **Traffic Engineering Division (Traffic Engineering)** for review.

PCC pavement requires the following types of joints to control cracking from the stresses induced by volume changes in concrete:

1. Contraction joints are located in the pavement to relieve stresses caused by shrinkage, thermal contraction, and moisture or thermal gradients. Joint spacing generally divides the pavement into sections of approximately the same length and width (the length to width ratio will not exceed 1.5). Longitudinal contraction joints are normally located between traffic lanes (see Section 2.A.2.a of this chapter). Transverse contraction joints are perpendicular to the centerline and will include load transfer devices across the joint.
2. Expansion or Isolation joints are used primarily to provide separation between the pavement and other structures such as bridges and inlets or at other pavement sections such as pavement slabs at intersections.
3. Construction joints shall be placed at the end of each day's work or whenever the paving operation ceases for over 30 minutes. Construction joint location will be determined in the field.

Load transfer devices (smooth steel dowel bars) are used at transverse joints to transfer the load across the joints; these devices offer little resistance to longitudinal movement at the joint. Tie bars (deformed reinforcing steel) are used to hold the faces of adjacent slabs in firm contact with one another and are not designed to act as load transfer devices.

The following joints will have the specified connections:

**Transverse Joints**

Joint Type	Connection Type
Contraction	Dowel bar
Expansion	Dowel bar
Construction	Dowel bar

**Longitudinal Joints**

Joint Type	Connection Type
Between Lanes	Tie bar
Construction	Tie bar

See the *Standard Plans* (Ref. 8.1), Standard Plan 329 for details of bars at joints and joint spacing.

### 2.A.2.a Policy for Longitudinal Joints

NDOT has determined that PCC pavement that is wider than 12 feet shall be designed with the following guidelines:

- 28-foot-wide roadways with 14 feet wide panels will not have a longitudinal joint regardless of pavement thickness
- Outside lanes as part of an expressway or Interstate will have a longitudinal joint between the 12-foot-wide driving lane and outside shoulder, regardless of pavement thickness
- Inside lanes as part of the Interstate system will not have a longitudinal joint between the inside lane and the inside shoulder when the inside shoulder width is four foot or less
- Inside lanes as part of an expressway system that have a 10-inch thickness or less will have a longitudinal joint between the inside lane and the inside shoulder.
- Lane width dimensions to the back of curb greater than 14 feet will have a longitudinal joint at the width of 12 feet
- Roundabout transverse and longitudinal joint widths will not exceed 14 feet

### 2.A.3 Joining Existing Pavement

When a project includes new concrete pavement to be placed adjacent to existing concrete pavement it will be necessary to install tie bars on the longitudinal joints. Tie bars are pay items when joining to existing pavement, the designer is responsible for calculating the tie bar quantities. Build notes for these tie bars are not required, the information shown on the summary of quantities sheet is considered to be sufficient.

Dowel bars are required when joining new pavement to existing pavement at a transverse joint. Dowel bars are not paid for directly but are subsidiary to doweled concrete pavement.

### 2.A.4 Tining

PCC pavement will be tined when the posted speed limit of a roadway is 40 mph or greater. When a mainline is tined, intersections, acceleration lanes, deceleration lanes, left turn lanes, and ramps will also be tined; tining details are included in the *Standard Plans* (Ref. 8.1), Standard Plan 329. If only part of a project is to be tined a note will be placed on the Typical Cross-Section sheet itemizing the areas which will not be tined (See Chapter Eleven: Highway Plans Assembly, Section 4.B, of this manual).

## 2.B Flexible Pavement

Flexible pavement is characterized by an asphaltic structure which depends on aggregate durability and gradation, air voids, binder content, and angularity for strength, cohesion and stability.

## 2.C Surfacing Aggregates

Crushed rock or gravel may be used to surface county roads, driveways, at the end of driveway or intersection returns, for temporary roads, for temporary access to properties during project construction, etc. When crushed rock or gravel surface course is specified for a temporary road the designer will also specify crushed rock or gravel embedment.

### 3. PAVEMENT SUBDRAINS

Because drainage is an important factor in pavement performance, subgrade drainage is an important consideration in pavement design. **M&R** determines the need for and type of subgrade drainage during the pavement determination process. **M&R** also prepares the special provisions for subgrade drainage.

Granular subdrains are built by digging a trench that is sloped to convey water away from the roadway which is then backfilled with granular material. When the granular subdrain runs parallel to the roadway it is referred to as a “Longitudinal Subdrain” and the pay item is in units of linear feet; all other material and labor is subsidiary. When granular material is used as an outlet to convey water to the roadside ditch it is referred to as a “Granular Subdrain” and the pay item is each, all other material and labor is subsidiary.

When additional water conveyance is needed a slotted pipe is placed at the bottom of the trench, which has been lined with a filter fabric, and is then backfilled with granular material. The pay item for this installation is “Pipe Underdrain”, paid for by the linear foot, all other material and labor being subsidiary.

The measurement of the spacing between granular subdrain or pipe underdrain outlets should begin at the outlets located in sag locations. Outlets should be constructed at intervals of 200 feet where the grade is 1% or greater and at intervals of 100 feet on grades of less than 1%.

For additional information, see the “Information” section of the *Standard Plans* (Ref. 8.1), plans 430 and 431.

## 4. SHOULDERS

The minimum shoulder width is established by the functional highway classification as described in the Nebraska Minimum Design Standards (MDS) (Ref. 8.2) (<https://dot.nebraska.gov/media/1z1n5kmb/nac-428-rules-regs-nbcs.pdf>).

### 4.A Concrete Shoulders

Concrete shoulders will be paid for as “\*\* inch Concrete Pavement”. “Earth Shoulder Construction” (See Section 4.D of this chapter) must be paid for and will be shown on the Typical Cross-Section sheet (See Chapter Eleven: Highway Plans Assembly, Section 4.B, of this manual). “Shoulder Subgrade Preparation” may be used when shoulders are added to an existing highway; the excavated soil is used for shouldering and there is no pay item for earth shoulder construction in this case. The shoulder dimensions will be shown on the Typical Cross-Section sheet; a note will be included on the typical section referring to the material to be removed by the surfacing contractor.

### 4.B Asphalt Shoulders

The pay items for asphalt shoulders include “Asphaltic Concrete” (in tons), “PG Binder” (in tons), “Tack Coat” (in gallons), “Hydrated Lime/Warm Mix Asphalt” (each), and “RAP Incentive” (each).

### 4.C Earth Shoulder Construction

Where new pavement is being built the subgrade will be designed an additional 0.2 feet high for trimming. This excess material is available for incorporation into the earth shoulder, as shown in EXHIBITS 8.1a & 8.1b. Soil materials used for earth shoulder construction must have the capability to support vegetation. Trimming of the subgrade for shouldering material will be completed prior to the Stabilized Subgrade operation. Sources of shoulder materials include:

- Excess excavation
- Located sites within state right-of-way (station-to-station)
- Locations outside the state right-of-way (borrow pits, contractor’s responsibility)

Areas designated as sources of shoulder material should not be disturbed. Disturbed areas will be protected from erosion through cover crop seeding, sodding, etc. See Chapter Two: Erosion and Sediment Control, Section 6, of the Drainage Design and Erosion Control Manual (Drainage Manual) (Ref. 8.3) for additional information (<https://dot.nebraska.gov/media/ajjpyh3d/e-chap-2-erosion-control.pdf>).



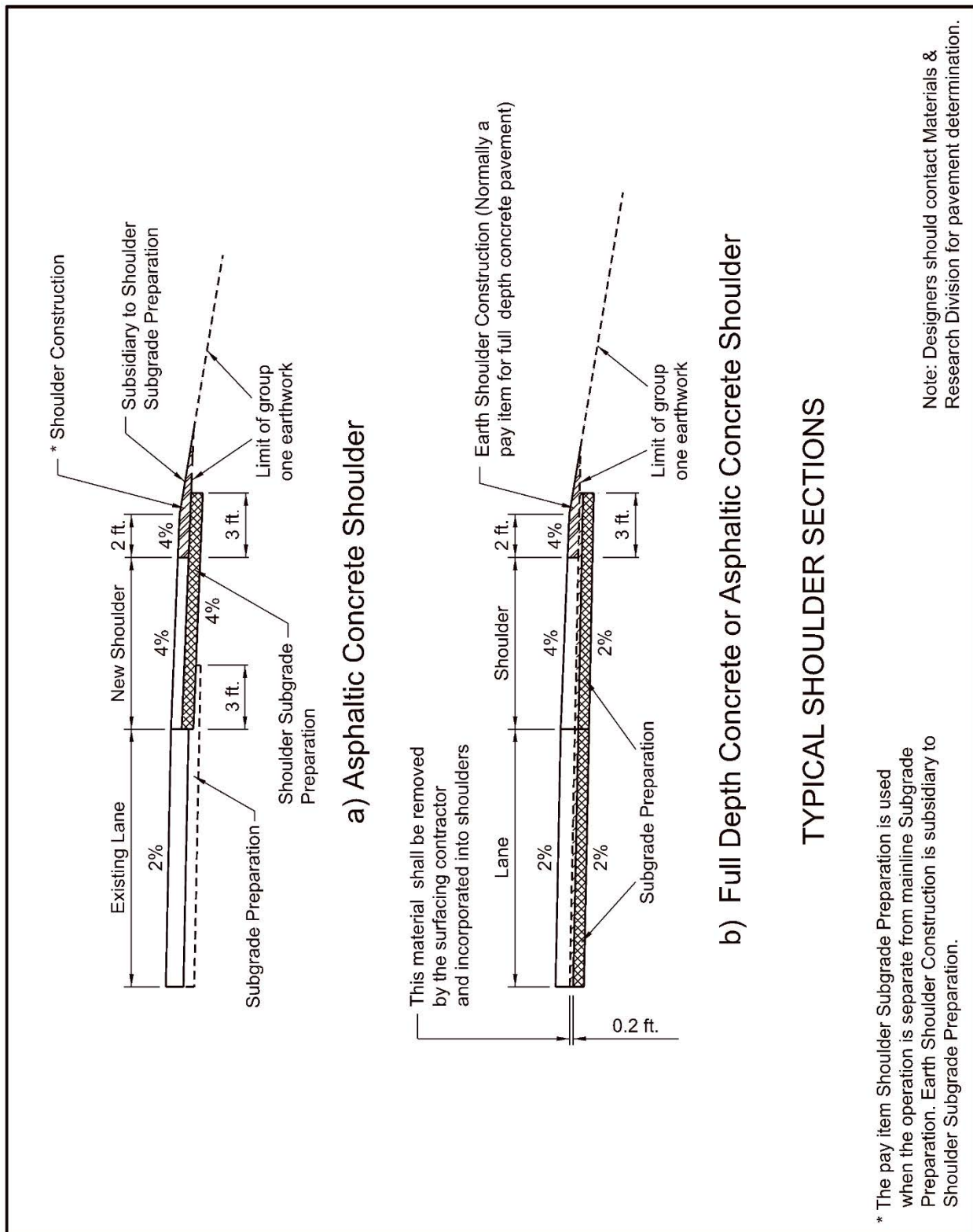


Exhibit 8.1a Typical Shoulder Construction (Uncurbed Section)

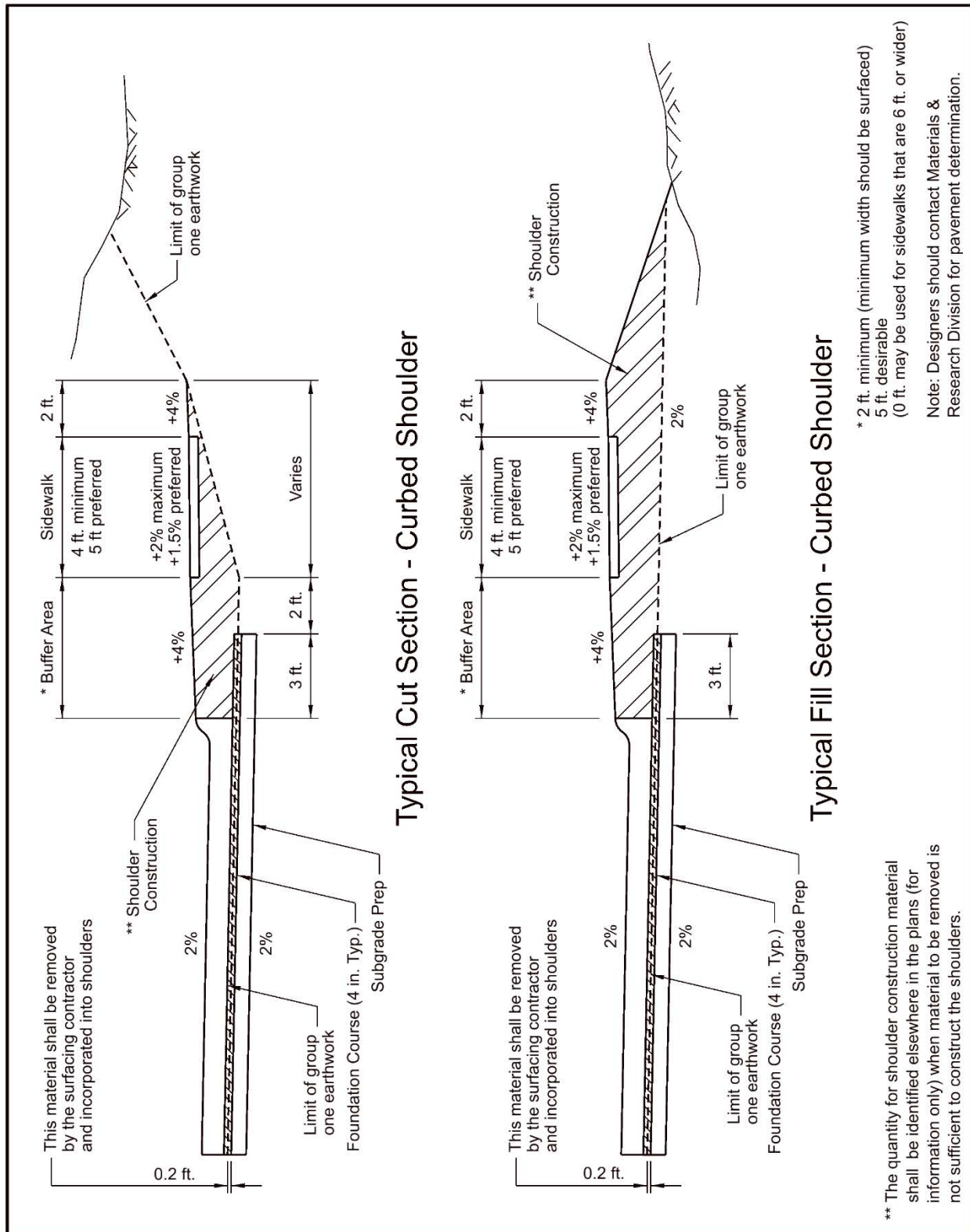


Exhibit 8.1b Typical Shoulder Construction (Curbed Section)

## 5. PAVEMENT REHABILITATION

Pavement rehabilitation techniques have been developed to extend or enhance the service life of a roadway. Pavement rehabilitation analysis is performed to:

- Determine the cause(s) of pavement distress
- Develop a list of possible solutions to cure and prevent recurrence of the problem(s)
- Select the preferred rehabilitation method, accounting for economic and other project constraints

Data used to determine the cause(s) of the problem(s) include those items described in Section 1.A as well as the pavement condition-distress severity and extent.

### 5.A Types of Rehabilitation

See Chapter One: Roadway Design Standards, Sections 6.B & 6.C, and Chapter Seventeen: Resurfacing, Restoration and Rehabilitation (3R) Projects, Section 1, of this manual.

### 5.B Removal of Existing Surfacing

The pay items “Remove Asphalt Surface” and “Remove Pavement” refer to the removal of the surfacing down to the roadway base. Existing surfacing may be removed when it is no longer cost effective to repair and to accommodate surfacing thickness requirements at railroad crossings, bridge ends or other locations shown on the plans. When the final thickness of surfacing is reduced by milling, **M&R** should be consulted to confirm that the reduced thickness will provide adequate structure. For additional information, see Chapter Seven: Earthwork, Section 1.C, of this manual.

#### 5.B.1 Cold Milling

Cold milling is the removal of existing asphaltic concrete by a milling machine. Cold milling may be one of several different types, depending on the depth of milling and slope requirements outlined in the pavement determination from **M&R**. The different types vary from milling to remove surface irregularities to milling to remove the entire depth of existing asphalt. Milling is paid for at the contract unit price per Sta. or per SY as detailed in the *Spec Book* (Ref. 8.4), Section 510 (<https://dot.nebraska.gov/media/g4qp4y0d/2017-specbook.pdf>).

#### 5.B.2 Brick Removal

A special provision is required whenever brick surfacing is removed and salvaged. The roadway designer will note the need for this provision in the final plans package for **PS&E**. For additional information see Chapter Twelve: Cost Estimating and Funding of this manual.

#### 5.B.3 Concrete Surface Milling

Concrete Surface Milling is the removal of concrete by a milling machine and is described by the typical cross-sections and special provision. Concrete Surface Milling is paid for at the contract unit price per Sta. or per SY as detailed in the *Spec Book* (Ref. 8.4), Section 510.

### 5.C Concrete Repair and Bituminous Pavement Patching

Concrete Pavement - Repair of concrete pavement consists of the removal and replacement of irregular areas of existing concrete pavement including overlaying bituminous surfacing and/or unstable base course. See the *Spec Book* (Ref. 8.4), Section 605, for additional information.

Asphaltic Concrete - Patching of asphaltic concrete consists of the removal and disposal of unstable or deteriorated materials (including base course, if necessary) and the placing and compacting of the appropriate type of asphaltic concrete. Quantities for pavement patching will be included in the project cost estimate; the designer will include the pay items for the rental of loader, motor grader, and dump truck with asphalt patching. See Section 516 of the *Spec Book* (Ref. 8.4) for additional information.

### 5.D Overlays and Transitions

Asphaltic concrete overlays are used in a variety of situations. A specified depth or grade line of existing bituminous material is removed by cold milling and then the asphalt is laid down. At locations where differences in elevation occur as the result of an overlay, a transition detail or inlay detail is required on the Typical Cross-Section Sheet (See Chapter Eleven: Highway Plans Assembly, Section 4.B, of this manual). A minimum taper rate of 33 feet to one-inch change in grade should be used on high-speed ( $V \geq 50$  mph) roadways; the preferred taper rate of an overlay on a high-speed roadway is 50 feet to each inch change in grade (e.g. for a two-inch mill with a four-inch overlay:  $2 \times 50 = 100$  feet). The taper rate for a low-speed ( $V \leq 45$  mph) roadway is 25 feet to each inch change in grade.

#### 5.D.1 Template Correction

Template correction is used when the existing cross slopes are different from the design cross slopes (e.g. 3% existing cross-slope vs 2% design cross slope). **Roadway Design** will provide an estimate of the additional tons of asphalt needed for the cross slope correction to **M&R** when the project is being prepared for **PS&E** turn-in.

#### 5.D.2 Superelevation Improvement

Superelevation improvement is considered when the existing superelevation does not meet the *MDS* (Ref. 8.2) guidance. **Roadway Design** will provide an estimate of the additional tons of asphalt needed for the superelevation improvement to **M&R** when the project is being prepared for **PS&E** turn-in. For additional information see Chapter Seventeen: Resurfacing, Restoration and Rehabilitation (3R) Projects, Section 3.B.1, of this manual.

### 5.E Pavement Dropoffs During Construction

It is the responsibility of the roadway designer to inform **Traffic Engineering** of projects being built under traffic where grading operations are adjacent to the existing roadway.

## 6. SURFACING QUANTITY COMPUTATIONS

The procedure for computing quantities of surfacing material depends on the type of pavement to be placed. Cost estimates will be made based on the computed quantities. For additional information see Chapter Twelve: Cost Estimating & Funding of this manual.

### 6.A Rigid Pavement

The roadway designer is responsible for computing PCC pavement pay quantities, including the following items:

- Concrete pavement, including intersections and driveways, for each design pavement thickness (See Chapter Four: Intersections, Driveways and Channelization, Sections 3.A and 3B, of this manual)
- Concrete curb
- Left-in-Place Median Crossovers (See Chapter Five: Interstates, Grade Separations, and Interchanges, Section 1.H.4, of this manual).

The designer will compute separate total areas for each pavement thickness, including the mainline, intersections, driveways, approaches, turnouts, etc. This area, in sq. yds., is the estimated pay item quantity for each depth of concrete pavement.

Concrete pavement quantities should be itemized and shown on the computation sheets in such a manner that the segments of pavement represented can be easily recognized. In cases where the design is very complex sketches should be included with the computation sheets. The designer should refer to Chapter Twelve: Cost Estimating & Funding, EXHIBITS 12.8 & 12.9, for a list of surfacing pay items. The designer will submit the typical sections, plan and profile or large scale sheets, intersection and driveway sheets and locations, and the concrete pavement pay item quantities to **M&R**; **M&R** requires this information to compute the quantities for Subgrade Preparation and Foundation Course.

## 6.B Flexible Pavement

The designer will submit the essential project information, including typical sections, complete plan and profile or large-scale sheets, driveway sketches and locations, surfacing under guardrail details, etc. and the summary of asphaltic concrete quantities to **M&R**, which is responsible for computing the final pay quantities for asphaltic concrete surfacing.

The roadway designer will verify that the flexible pavement quantities include asphaltic concrete surfacing used for:

- Driveways and intersections (See Chapter Four: Intersections, Driveways and Channelization, Section 3, of this manual)
- Mailbox turnouts (See Chapter Ten: Miscellaneous Design Issues, Section 10, of this manual)
- Surfacing under guardrails (See Chapter Nine: Guardrail and Roadside Barriers, Section 3.G, of this manual)
- Surfacing for detours, temporary roads, crossovers, and temporary pavement (See Chapter Fourteen: Traffic, Section 6, of this manual)
- Asphaltic concrete curb

For a list of surfacing pay items, see Chapter Twelve: Cost Estimating & Funding, EXHIBITS 12.8 & 12.9.

## 6.C Surfacing Aggregates

Quantities for aggregates used for surfacing are computed either by the ton or cu. yd., depending on the **District**. In **Districts 1, 2 and 3** surfacing aggregate estimates will be calculated in tons; when surfacing aggregates are needed in **Districts 4 through 8** the designer should consult with the **DE** during the plan-in-hand to determine the unit of measurement and the type of aggregate to be used. The following weight to volume factors should be used in estimating:

Crushed rock for surfacing:	1.25 tons/cu. yd.
Gravel for surfacing:	1.35 tons/cu. yd.

On projects where grading disrupts property access, the designer should consult with the **DE** on the plan-in-hand field inspection regarding the use of gravel, crushed rock, or millings to provide temporary access to the impacted properties. The designer should include a lump sum for these quantities in the preliminary project estimates; the quantities should vary between 100 to 200 tons per mile, depending on the size of the access and the type of roadway (e.g. two-lane vs. four-lane, municipal vs. rural). Quantities will be shown to the nearest ton. The designer will submit plans, cross-sections, and preliminary quantity estimates of locations using surfacing aggregates to **M&R** for the computation of the final quantities.

For a list of surfacing pay items see Chapter Twelve: Cost Estimating & Funding, EXHIBITS 12.8 & 12.9.

## 6.D Foundation, Base, and Surface Courses

Pay item quantity units and methods of measurement for roadway foundation, base, and surface courses are found in the *Spec Book* (Ref. 8.4), Division 300.

## 6.E Sawing Pavement

The pay item "Sawing Pavement" will be included when removing pavement, sidewalk, driveway, integral curb, or similar flatwork when the removal does not extend to an existing joint. The pay item includes both full depth and partial depth cuts. "Sawing Pavement" is required when removing concrete overlaid with asphalt.

The designer should calculate the length of the transverse cut and longitudinal integral cuts required to remove a curb, portion of a lane, or similar cuts. The quantity should be rounded to the nearest 10 feet. "Sawing Pavement" is not calculated when the removal occurs at existing joints. Sawing notes should not be shown in the plans.

## 7. RUMBLE STRIPS AND RUMBLE STRIPES

Reducing the occurrence of vehicles deviating from their assigned lane by either leaving the roadway or encroaching on or crossing into opposing lanes is one of the critical emphasis areas for the Nebraska Strategic Highway Safety Plan (<https://dot.nebraska.gov/safety/shsp/>). Installation of rumble strips and rumble stripes is a cost-effective measure, recognized by federal and state transportation agencies, for alerting errant drivers of lane departure and providing the driver with an opportunity to correct back into their lane, potentially mitigating lane departure crashes.

Rumble strips are grooved patterns in the pavement, typically spanning 6 inches and either 12 inches or 16 inches wide on 12-inch spacing. When a vehicle crosses a rumble strip the vehicle shakes and the vibration causes a noise, alerting the driver that the vehicle is leaving the travel lane. Shoulder rumble strips are milled into the shoulder surfacing.

Rumble stripes are relatively narrow, 8 inches wide on 12-inch spacing. Edge line rumble stripes are placed in the location of the white edgeline and are generally used where the surfaced shoulders are less than 6 feet in width. Centerline rumble stripes are milled on each side of the joint separating opposing lanes of traffic. Rumble stripes are placed in the paint stripe of the centerline and/or at the edge line of the lane but will not be on a joint. Rumble stripes will be paid for as rumble strips.

Rumble strips will not be placed on bridge decks or bridge approach slabs.

Rumble strip installation should follow Special Plan 320 (See the *Standard Plans*, Ref. 8.1).

Each shoulder receiving rumble strips shall be measured separately, in stations of 100 feet. Centerline rumble strips shall be measured in stations of 100 ft. Stations are measured horizontally along the project centerline between the project beginning and ending points. Deductions will be made by the **District** for all areas where rumble strips are not required, the roadway designer is not responsible for the deductions.

Rumble strips are paid for by the Station (Sta). The appropriate pay items are "Rumble Strips, Asphalt", "Rumble Strips, Concrete", and/or "Centerline Rumble Strips".

When rumble strips, edge line rumble stripes or centerline rumble stripes are placed they will be perpetuated on subsequent projects and will not be obliterated without their function being replaced with a similarly effective mitigation measure for road departures (e.g. lighting). Since the installation of rumble strips/stripes will substantially modify the run-off road crash history, use of the warrants to justify continued use of the rumble strips/stripes would be inaccurate. If **NDOT** maintenance operations or activities obliterate the rumble strips/stripes, they are not required to be reinstalled until the next resurfacing project. Rumble strips/stripes may be restored earlier if directed by the **DE**. Rural areas which become urban may eliminate the rumble strip/stripe.

Additional information may be found at:

- NCHRP Report 641, Guidance for the Design and Application of Shoulder and Centerline Rumble Strips, 2009.
- Low-Cost Treatments for Horizontal Curve Safety, FHWA, 2006.
- Shoulder and Edge Line Rumble Strips, FHWA Technical Advisory T 5040.39, November 7, 2011
- NCHRP Synthesis 339, Centerline Rumble Strips, 2005

For additional rumble strip/stripe guidance on 3R projects, see Chapter Seventeen: Resurfacing, Restoration and Rehabilitation (3R) Projects, Section 8.B, of this manual.

## 7.A Shoulder Rumble Strips

After reviewing the crash data and research literature, **NDOT** has determined the following to be guiding principles for the installation of shoulder rumble strips on the state highway system.

- Shoulder rumble strips will be constructed on the shoulders, including the median shoulders, for all rural Interstate and rural expressway projects (new construction, reconstruction, and 3R).
- Shoulder rumble strips should be constructed on 6-foot-wide or wider surfaced shoulders for all new construction and reconstruction projects on rural high-speed ( $V \geq 50$  mph) two-way two-lane highways.
- Shoulder rumble strips should be constructed on 3R projects over one-half mile in length on rural high-speed ( $V \geq 50$  mph) highways with continuous surfaced shoulder widths of 6 foot or greater.
- Existing rumble strips will be perpetuated on 3R projects over one-half mile in length. When project lengths are less than one-half mile, the rumble strips may be added to another project in the area to reduce mobilization fees.
- Projects with surfaced shoulders with curb and flume will be reviewed for inclusion of milled in rumble strips by **Roadway Design**.

Shoulder rumble strips may be placed at the direction of the **Traffic Engineer** or designee to address other traffic operations issues beyond those presented here.



## 7.B Edgeline Rumble Stripes

**NDOT** has determined through demonstration projects, national studies, and Nebraska crash history analysis that the installation of edgeline rumble stripes is an effective countermeasure for roadway departure crashes on two-lane two-way roadways. **NDOT** also recognizes that installing edgeline rumble stripes utilizes transportation funds that could be available for other transportation needs on the state highway system. A systematic or systemic approach to the implementation of safety mitigation strategies is important regardless of the mitigation strategy to be used. Due to the random occurrence of roadway departure crashes, it is important to recognize that any roadway departure crash could be a fatality based upon the random presence of another vehicle, the roadside configuration, and the health of the individuals involved in the crash. Consequently, this policy for implementation is based upon the total number of roadway departure crashes.

After reviewing the crash data and research literature, **NDOT** has determined the following to be guiding principles for the installation of edgeline rumble stripes on the state highway system new pavement projects. Edgeline rumble stripes may be placed on existing state highway pavement at the direction of the **M&R Engineer** or designee.

- Roadway type – Rural two-lane undivided with two-way traffic
- Lane width – 12 feet with two-foot integral shoulders for a 28-foot minimum total top width
- Pavement section with a recommended minimum overlay thickness of two inches of pavement and the surface in good condition
- Posted speed limit of 50 mph or greater

After edgeline rumble stripes are installed, they will be perpetuated on subsequent projects unless their function is replaced by a similarly effective mitigation measure for roadway departure crashes, speed limit of the segment is reduced to 45 mph or lower, or the new pavement overlay thickness is less than two inches. Edgeline rumble stripes may be placed on new pavement overlays with a thickness of less than two inches at the direction of the **M&R Engineer** or designee.

### 7.C Centerline Rumble Stripes

**NDOT** has determined through demonstration projects, national studies, and Nebraska crash history analysis that the installation of centerline rumble stripes is an effective countermeasure for lane departure crashes on two-lane two-way roadways. **NDOT** also recognizes that installing centerline rumble stripes utilizes transportation funds that could be available for other transportation needs on the state highway system. A systematic or systemic approach to the implementation of safety mitigation strategies is important regardless of the mitigation strategy to be used. Due to the random occurrence of lane departure crashes, it is important to recognize that any lane departure crash could be a fatality based upon the random presence of another vehicle, the roadside configuration, and the health of the individuals involved in the crash. Consequently, this policy for implementation is based upon the total number of lane departure crashes.

After reviewing the crash data and research literature, **NDOT** has determined the following to be guiding principles for the installation of centerline rumble stripes on the state highway system new pavement projects. Centerline rumble stripes may be placed on existing state highway pavement at the direction of the **M&R Engineer** or designee.

- Roadway type – Rural two-lane undivided with two-way traffic
- Lane width – No less than 11 feet; the lane width will be 12 feet minimum where edgeline rumble stripes are present
- Pavement section with a recommended minimum overlay thickness of two inches of pavement and the surface in good condition
- Posted speed limit of 50 mph or greater

After centerline rumble stripes are installed, they will be perpetuated on subsequent projects unless their function is replaced by a similarly effective mitigation measure for lane departure crashes or if the new pavement overlay thickness is less than two inches. Centerline rumble stripes may be placed on new pavement overlays with a thickness of less than two inches at the direction of the **M&R Engineer** or designee.

### 8. **BEVELED EDGE**

See Chapter Six: The Typical Roadway Cross-Section, Section 2.C, of this manual.

### 9. **SURFACING ELEVATIONS**

See Chapter Eleven: Highway Plans Assembly, Section 4.J.1, of this manual.

## 10. REFERENCES

- 8.1 Nebraska Department of Transportation, Standard/Special Plans Book (*Standard Plans*), Current Edition. (<https://dot.nebraska.gov/media/g4qp4y0d/2017-specbook.pdf>)
- 8.2 Board of Public Roads Classifications and Standards, Nebraska Minimum Design Standards (*MDS*), Current Edition. (<https://dot.nebraska.gov/media/1z1n5kmb/nac-428-rules-regs-nbcs.pdf>)
- 8.3 Nebraska Department of Transportation, Drainage Design and Erosion Control Manual (*Drainage Manual*), Current Edition. (<https://dot.nebraska.gov/business-center/design-consultant/rd-manuals/>)
- 8.4 Nebraska Department of Transportation, Standard Specifications for Highway Construction (*Spec Book*), 2017. (<https://dot.nebraska.gov/media/g4qp4y0d/2017-specbook.pdf>)
- 8.5 Nebraska Department of Transportation, Design Process Outline (*DPO*), Current Edition. (<https://dot.nebraska.gov/business-center/design-consultant/>)



The information contained in Chapter Nine: Guardrail and Roadside Barriers, dated May 2022, has been updated to reflect the January 2023 Errata. The errata addresses errors, changes in procedure, changes in NDOT department titles, changes in other Roadway Design Manual chapters and other reference material citations occurring since the latest publication of this chapter.

Chapter Nine presents guidance for the design of New and Reconstructed projects; design guidance for 3R projects is provided in Chapter Seventeen.

Except as otherwise noted, existing roadside barriers must be reviewed for compliance with the National Cooperative Highway Research Program (NCHRP) Report 350 or the Manual for Assessing Safety Hardware (MASH). Short radius W-Beam guardrail installations (See Section 7.A of this chapter) shall be in compliance with NCHRP Report 230.

## Chapter Nine

# Guardrail and Roadside Barriers

The **Nebraska Department of Transportation (NDOT)** will use the guidance found in the Roadside Design Guide (Ref. 9.1) for the evaluation and design of the roadside geometry, guardrail, and roadside barriers. This chapter includes additional **NDOT** guidance for New and Reconstructed projects (See Chapter Seventeen: Resurfacing, Restoration and Rehabilitation (3R) Projects, Section 9, of this manual for barrier guidance on 3R projects).

A roadside barrier may be used to shield traffic from critical slopes, cross-median traffic, and other obstacles along the roadside. The barrier is an obstacle itself and should not be used when it presents a greater crash potential than the object or condition being shielded.

Barrier installations at intersections will be reviewed for intersection sight distance (See Chapter Four: Intersections, Section 1.C.2, of this manual). Barrier selection and placement should also take snow drifting into consideration since the barrier may act as snow fence. The designer should check with the **District Engineer (DE)** prior to and on the plan-in-hand field inspection for potential snow drifting areas.

Whenever significant pedestrian and/or bicycle traffic is anticipated special attention must be paid to the deflection characteristics of the barrier (See Section 3.D.1 of this chapter).

## 1. BARRIER JUSTIFICATION

A study to determine whether a barrier is desirable should include:

1. Determination of the clear-zone distance
2. Identification of the obstacle(s)
3. Consideration of your options
4. Performance of a cost effectiveness analysis for viable options

### 1.A Determination of the Clear-Zone Distance

For New and Reconstructed projects the clear-zone distance is the roadside area, starting at the edge of the through lane, which is available for the recovery of vehicles leaving the roadway. The clear-zone distance provides an area free of fixed obstacles and should consist of the shoulder and either a recoverable slope or a traversable slope with a clear runout area.

The minimum required clear-zone width is given in the Nebraska Minimum Design Standards (MDS) (Ref. 9.2) (<https://dot.nebraska.gov/media/1z1n5kmb/nac-428-rules-regs-nbcs.pdf>) as determined by the roadway classification, ADT, and design speed.

For additional information see Chapter Six: The Typical Roadway Cross-Section, Section 9, of this manual.

### 1.B Identification of the Roadside Condition

The designer should use the survey and/or photo imagery to identify roadside obstacles.

### 1.C Consideration of Your Options

The designer should consider the following options when determining the appropriate treatment for an obstacle:

1. Remove the obstacle.
2. Redesign the obstacle so it can be traversed.
3. Relocate the obstacle to a location where it is less likely to be hit, preferably beyond the clear-zone distance.
4. If the obstacle is a sign support, traffic signal support, or utility pole that cannot be relocated, use breakaway devices where feasible.
5. Shield the obstacle if feasible and cost effective to do so.
6. If no other option is practicable, delineate the obstacle to reduce impacts.

EXHIBIT 9.1 is a partial listing of potential roadside conditions and considerations.

Roadside Condition	Decision Considerations
Foreslopes and Backslopes	The slope and the clear-zone distance.
Bridge piers, abutments and end of bridge rail	The location and the clear-zone distance. The end of the bridge rail is typically shielded with guardrail.
Cross-Median Traffic	The median width, traffic speed, traffic volumes, and percentage of heavy trucks.
Boulders	The nature and size of the obstacle and the likelihood of impact.
Culverts, pipes, headwalls	Crossroad culverts 36 inches or less in diameter with flared end sections, round-equivalent culverts 36 inches or less in width with flared end sections, and multiple-pipe installations of culverts 30 inches or less in diameter with flared end sections may be included within the clear-zone distance, typically without protection. Larger culverts may require either a traversable end section, extension outside of the clear-zone distance, or a cost effectiveness analysis to determine if barrier protection is economically warranted. Driveway culvert pipes parallel to the highway are typically placed at the back of the ditch, outside of the clear-zone distance. Headwalls are typically located beyond the clear zone distance.
Ditches (parallel)	The foreslope, backslope, depth, and the clear-zone distance. (See FIGURES 3-6 & 3-7 of the <u>Roadside Design Guide</u> , Ref. 9.1).
Ditches (transverse)	The approach transverse side slope (should be 1:6 or flatter inside of the horizontal clear zone) and the likelihood of impact (See Chapter Six: <u>The Typical Roadway Cross-Section</u> , Section 9.B.2, of this manual and Section 3.2.3 of the <u>Roadside Design Guide</u> , Ref. 9.1).
Embankment/Steep Slopes	The fill height, length of slope, slope geometry, and clear-zone distance. When fixed obstacles exist on the embankment slope the slope may not be the controlling factor: a cost effectiveness analysis should be based on the severity of the fixed obstacle (e.g. large culverts).
Retaining walls	The relative smoothness of the wall, anticipated maximum angle of impact, structural integrity of the wall when impacted, and the cost of repairs.
Sign/luminaire supports	Locate outside of the clear-zone distance whenever feasible. Shielding is generally required for non-breakaway supports when located within the clear zone.
Trees	Trees within the clear zone are typically removed.
Utility poles	Utility poles are typically relocated outside of the clear-zone distance whenever practicable. When utility poles cannot be relocated, the utility poles may be shielded. See Chapter Ten: <u>Miscellaneous Design Issues</u> , Section 12, of this manual for information regarding coordination with utilities.
Permanent bodies of water	The location and depth of the water and the likelihood of impact.

**Exhibit 9.1 Barrier Considerations for Roadside Conditions**

### 1.D Performance of a Cost Effectiveness Analysis

Barrier installation is sometimes based on a cost effectiveness analysis and the premise that a barrier should only be installed if it will reduce the severity of crashes. The cost effectiveness analysis program used by **NDOT** is the “Roadside Safety Analysis Program” (RSAP). RSAP is an encroachment-based computer software tool for cost-effectiveness evaluation of roadside safety improvements. **FHWA** has identified RSAP as a resource in roadside design. RSAP calculates the benefit to cost ratio, comparing the potential costs of impacting roadside obstacles to the expected benefit of shielding them and the lesser costs of impacting the barrier. The analysis can include, but is not limited to, consideration of the costs of:

- Removing or minimizing the obstacle
- The type and length of barrier
- The cost of barrier maintenance
- Crashes involving the barrier
- Crashes involving the roadside obstacle

## 2. **BARRIER TYPES USED IN NEBRASKA**

Details of the barrier types used in Nebraska are shown in the Standard/Special Plans Book (Standard Plans) (Ref. 9.3) (<https://dot.nebraska.gov/business-center/design-consultant/stand-spec-manual/>). EXHIBIT 9.2 summarizes the guidance for barrier use.



Barrier	Location	Comments
Semi-rigid Guardrail (Midwest Guardrail System (MGS), W-beam, and Thrie-beam)	Used to shield motorists from fixed objects such as bridge piers. Should not be placed on slopes steeper than 1:10. It is preferred that the posts be installed with the shoulder slope continuing for a minimum of two feet behind the system.	Semi-rigid guardrail relies on energy absorption of posts rotating in soil. For additional information, see Section 7, "Special Installations", of this chapter.
Cable Guardrail (Low-Tension)	Typically placed at four feet from the slope break point when the slope is 1:2 or flatter. Should not be placed within four feet of a slope between 1:1.5 and 1:2 or within 12 feet of a fixed object. Preferred over semi-rigid guardrail where snow drifting is likely.	This system relies on tensile forces in cables and the ability of impacting vehicles to ride down weak posts. Should not be placed on the inside of curves with radii less than 1910 feet unless additional space at a 1:10 or flatter slope is provided. Not typically placed on the inside of a curve with a Radius less than 716 feet.
Cable Guardrail (High-Tension)	Used for narrow medians (e.g. Interstate and expressway medians) to guard against cross-over crashes.	May have less deflection than Low-Tension Cable Guardrail and, typically, the installation will still be standing after a hit. <b>Roadway Design Engineer</b> approval is required for this installation.
32 inch Concrete Protection Barrier	Used in areas where barrier deflections are intolerable, truck capacity is required, or barrier repair is difficult. Should only be placed adjacent to surfaced shoulders or medians.	The New Jersey or F shape barrier is typically used in Nebraska.
42 inch or higher Concrete Protection Barrier	Used when the ability to contain large trucks is of primary concern. Locations with high volumes and narrow medians or where widening into a median is planned are the most common applications.	Height helps to reduce headlight glare somewhat and may redirect a semi-trailer to keep it from tipping over.
Vertical Concrete Barrier	Used where barrier deflections are intolerable, truck capacity is required, or barrier repair is difficult. May be higher than 32 inches.	Barrier provides high strength and low repair costs without high rollover rates. When initially taller than 32 inches, overlays may be placed next to it.
Bridge Approach Section/Special Bridge Approach Section	Typically used when semi-rigid guardrail is transitioned to a bridge rail on approach to a bridge.	Transitions from a semi-rigid guardrail section (W-Beam) to a rigid barrier section (concrete bridge rail).
Bullnose Median Barrier	Used in medians to shield motorists from sign bases, bridge ends, bridge piers, etc.	Requires 66 feet minimum clearance from the tip of the bullnose to the fixed object. The approaching terrain should be graded 1:10 or flatter for 60 feet prior to the bullnose.

Note: For additional information, see TABLE 5-3 of the Roadside Design Guide (Ref. 9.1).

### Exhibit 9.2 Nebraska Barrier Summary

### 3. GUARDRAIL DESIGN PROCEDURES

Once it has been determined that guardrail is the appropriate solution for a given location, its placement, length, type, etc. must be determined. The required length of a guardrail installation is a function of several variables, including:

- Design speed
- Design year ADT
- Runout length
- Lateral extent of the obstacle
- The tangent length of guardrail upstream from the obstacle
- The guardrail's lateral distance from the edge of the traveled way
- The flare rate for the specific type of guardrail installation

The following steps should be followed in guardrail design:

1. Determine the runout length and the lateral extent of the obstacle (See Section 3.A of this chapter).
2. Plot the runout path (See Section 3.B of this chapter).
3. Determine the appropriate guardrail flare rate (See Section 3.C of this chapter).
4. Select the guardrail components (See Section 3.D of this chapter).
5. Graphically locate the guardrail components on the plan (See Section 3.E of this chapter).
6. Design the earthwork around the guardrail (See Section 3.F of this chapter).
7. Determine the details of surfacing under guardrail (See Section 3.G of this chapter).
8. Determine the pay item quantities (See Section 9 of this chapter).

These steps are expanded upon in the following sections.

**3.A Determine Runout Length & Lateral Extent of the Obstacle**

Runout Length: The distance used to graphically determine the required length of a barrier. The runout length is measured along the edge of the lane from where a vehicle leaves the roadway to the obstacle being shielded as measured along the outside edge of the through travel lane. The runout length may be determined based on the design speed and traffic volume using EXHIBIT 9.3.

Design Speed (mph)	Runout Length (L <sub>R</sub> ) for Given Traffic Volume (ADT)			
	Over 10,000 veh/day	5000 to 10,000 veh/day	1000 to 5000 veh/day	Under 1000 veh/day
80	470 feet	430 feet	380 feet	330 feet
70	360 feet	330 feet	290 feet	250 feet
60	300 feet	250 feet	210 feet	200 feet
50	230 feet	190 feet	160 feet	150 feet
40	160 feet	130 feet	110 feet	100 feet
30	110 feet	90 feet	80 feet	70 feet

**Exhibit 9.3 Runout Length Values**  
 (Source: Roadside Design Guide, Ref. 9.1)

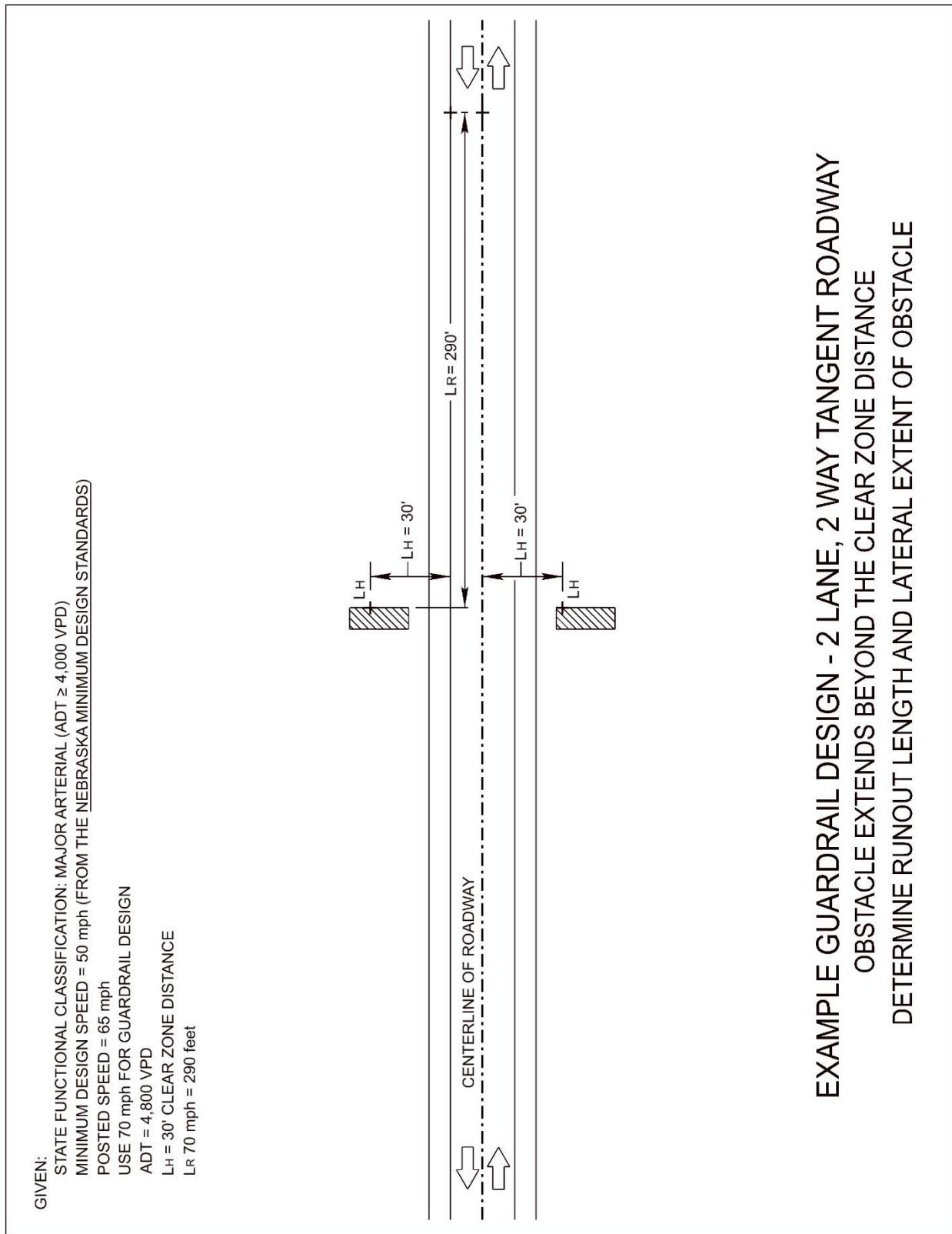
Lateral Extent of the Obstacle: The distance from the edge of the traveled way to the far side of a fixed obstacle. If the obstacle extends beyond the clear-zone distance the lateral extent of the obstacle is measured to the clear-zone distance.

The clear-zone distance listed in the *MDS* (Ref. 9.2) also applies to curved roadway segments in the following cases:

- When the obstacle is located outside a curve with a radius greater than 2,950 feet and there is no crash history
- When the obstacle is located inside the curve

When the obstacle is located on the outside of a curve with a radius of 2,950 feet or less, the clear-zone distance for the tangent roadway may be multiplied by the appropriate curve correction factor to arrive at an adjusted clear-zone distance to be used in plotting the runout path. For additional information see Section 3.B of this chapter and **TABLE 3-2** of the Roadside Design Guide (Ref. 9.1).

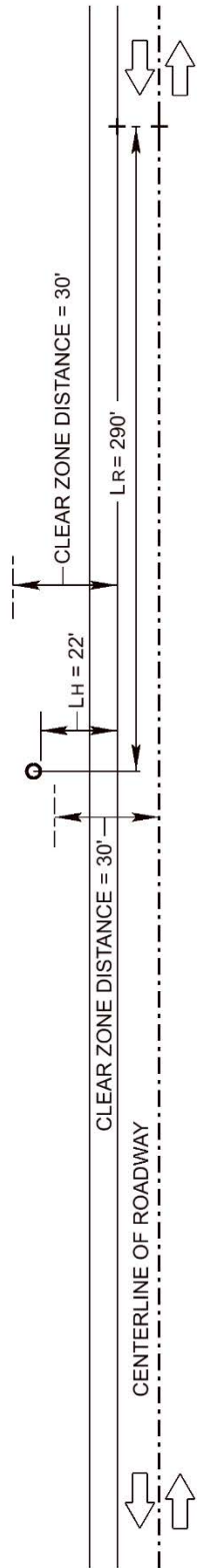
On two-way two-lane roadways guardrail is typically used to shield opposing traffic at bridge rails. The same guardrail design procedures are used for the opposing traffic, but the lateral extent of the obstacle and the runout length will be measured from the centerline of the two-way roadway (See EXHIBIT 9.4).



**Exhibit 9.4a Determine the Runout Length & Lateral Extent of Obstacle  
 (Obstacle Extends Beyond the Clear Zone Distance)**

GIVEN:

- STATE FUNCTIONAL CLASSIFICATION: MAJOR ARTERIAL (ADT  $\geq$  4,000 VPD)
- MINIMUM DESIGN SPEED = 50 mph (FROM THE NEBRASKA MINIMUM DESIGN STANDARDS)
- POSTED SPEED = 65 mph
- USE 70 mph FOR GUARDRAIL DESIGN
- ADT = 4,800 VPD
- LH RIGHT LANE = 30' CLEAR ZONE DISTANCE (OBSTACLE BEYOND CLEAR ZONE)
- LH LEFT LANE = 22'
- LR 70 mph = 290 feet



**EXAMPLE GUARDRAIL DESIGN - 2 LANE, 2 WAY TANGENT ROADWAY**  
 OBSTACLE INSIDE CLEAR ZONE DISTANCE  
 DETERMINE RUNOUT LENGTH AND LATERAL EXTENT OF OBSTACLE

**Exhibit 9.4b Determine the Runout Length & Lateral Extent of Obstacle (Obstacle Inside Clear Zone Distance)**

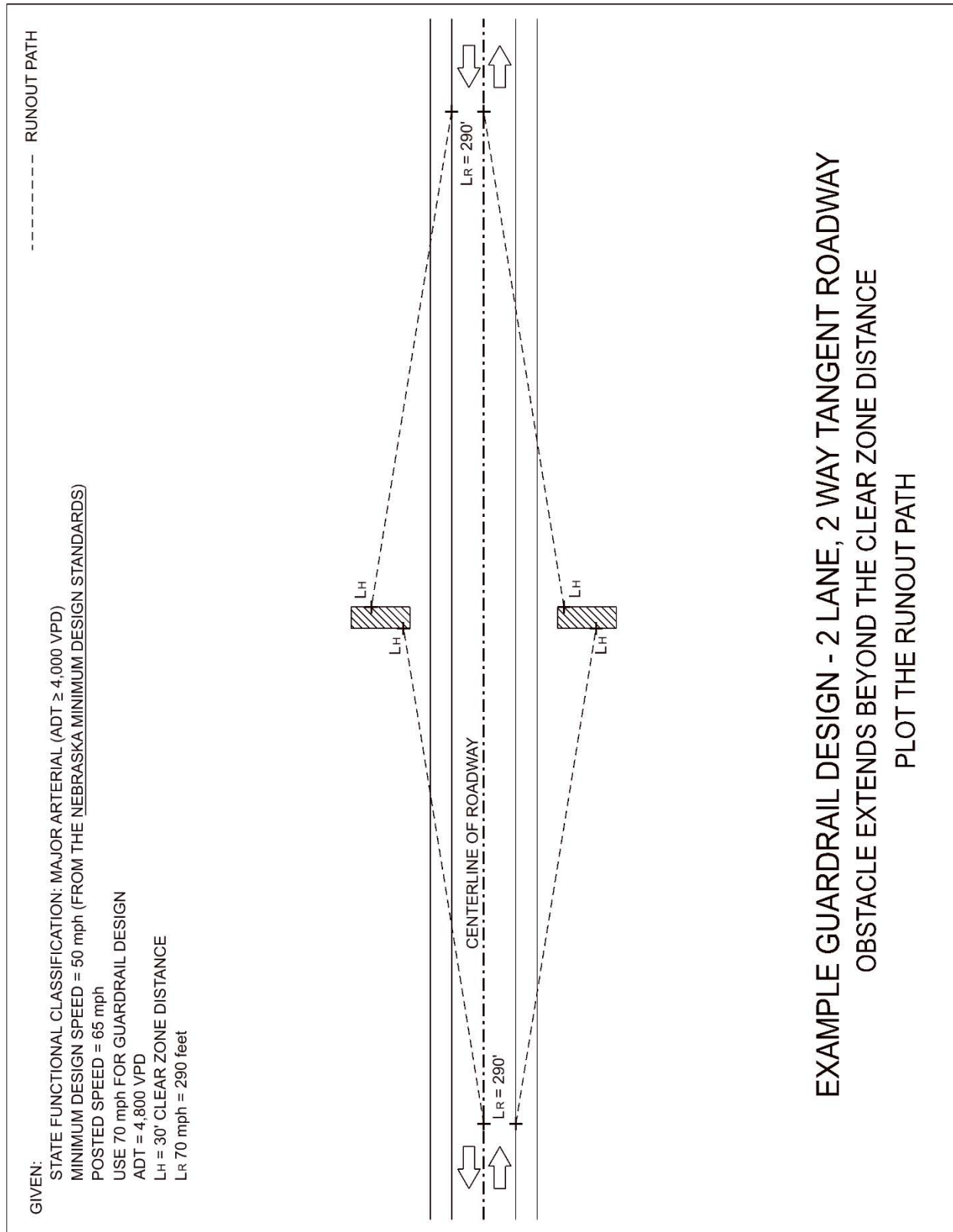
### **3.B Plot the Runout Path**

On tangent roadway segments, the runout path runs from the lateral extent of the obstacle to a point on the outside edge of the nearest driving lane which is at the runout length distance from the obstacle as measured along the edge of the lane (See [EXHIBIT 9.5](#)). The same procedure should be used on curved roadway segments where the curve radius is greater than 2,950 feet and for obstacles on the inside of the curve (See [EXHIBIT 9.7](#)).

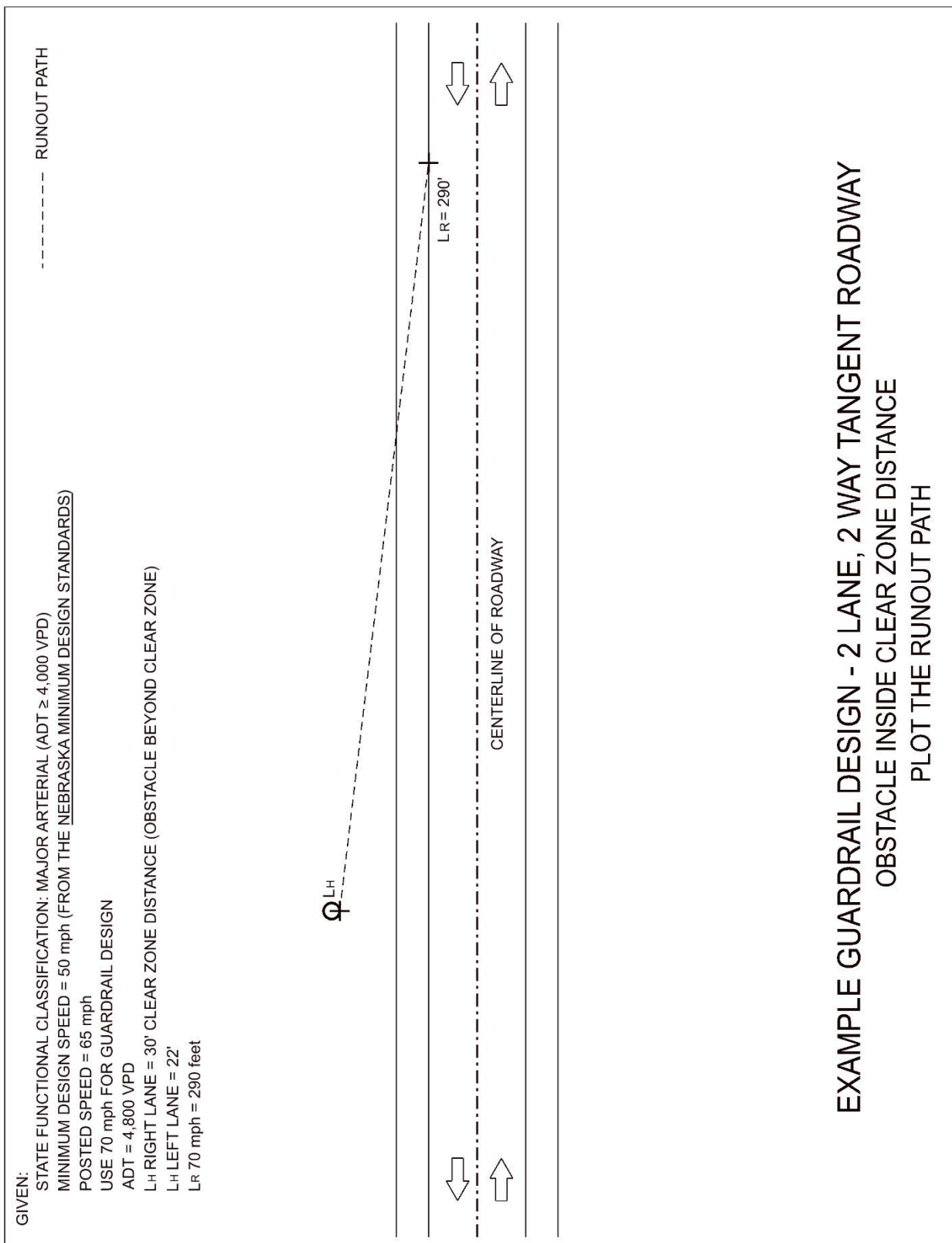
On curves with a radius of 2,950 feet or less, the runout path is plotted tangent to the outside edge of the driving lane so that it intersects the obstacle at the adjusted lateral extent of the obstacle (See Section 3.A of this chapter and [EXHIBIT 9.8](#)).

For MGS, W-beam, and Thrie-beam guardrail installations, a portion of the guardrail end treatment will not be included in the length of need. The runout path must intersect these end treatments at the beginning of length of need point as specified by the end treatment's manufacturer (See [EXHIBIT 9.6](#)).

For a low-tension cable guardrail installation, the runout path must intersect the guardrail at a distance of 15 feet or more from the end post of the in-line terminal anchorage system when used to shield a fixed object (See [EXHIBIT 9.9](#)).



**Exhibit 9.5a Plot the Runout Path  
 (Obstacle Extends Beyond the Clear Zone Distance)**



**Exhibit 9.5b Plot the Runout Path  
 (Obstacle Inside Clear Zone Distance)**



### 3.C Determine the Appropriate Flare Rate(s)

Typically, flare is used in guardrail installations to place the terminal section at a greater distance from the roadway and to shorten the required length of the barrier. Flare rate is a function of design speed and barrier type.

- A 25:1 flare rate is generally used for a Guardrail End Treatment, Type I (primarily installed with Midwest Guardrail System (MGS) and W-beam guardrail on multi-lane divided roadways)
- A 15:1 flare is used for a Guardrail End Treatment, Type II (generally used on MGS and W-beam guardrail on two-lane, two-way roadways).

Parallel installations or flatter flare rates are often used on projects with right-of-way constraints, to reduce environmental impacts, to reduce impacts to utilities, and/or where a limited amount of earthwork is desired. A parallel installation or a flatter flare rate increases the required length of the barrier.

The *Standard Plans* (Ref. 9.3), Standard Plan 743, includes guardrail post locations for the various flare rates.

### 3.D Select the Guardrail Components

Factors influencing guardrail selection include but are not limited to:

- Design speed
- Design year ADT
- Length and lateral offset of the obstacle
- Roadway geometry
- Median width (consider back-side impacts)
- Allowable deflection distance
- Cost
- The guardrail's lateral distance from the edge of the traveled way
- The flare rate for the specific type of guardrail installation

The following guidelines should be followed:

- Guardrail, when justified, should be connected to concrete bridge rail with an appropriate transition section (See Section 5 of this chapter). MGS or W-beam guardrail may be used on the off-end of one-way bridges when an obstacle is required to be shielded.
- MGS, W-beam, and Thrie-beam guardrail may be designed in multiples of 6.25 feet due to site restrictions, if that satisfies the required runout length.
- Use the appropriate terminal sections based on:
  1. Flare rate,
  2. The guardrail system,
  3. The roadway classification,
  4. The design speed, and
  5. **District** preference.

### 3.D.1 Deflection Distance

Selection and placement of guardrail is a function of the distance it will deflect upon impact. If the guardrail is shielding a rigid object, the distance between the guardrail and the object must be sufficient to avoid a vehicle contacting the object. Guardrail may not function properly in protecting traffic from a rigid object if the guardrail post(s) come in contact with the obstacle. See **TABLE 5-6** of the Roadside Design Guide (Ref. 9.1) for the required guardrail clearances and deflections.

- Low-tension cable guardrail deflects the greatest distance, by as much as 11.5 feet in crash testing. Low-tension cable guardrail should be designed with a 12 feet minimum deflection.
- High-tension cable guardrail systems have lower deflection distances, seven feet to nine feet in crash testing.
- Deflection characteristics of semi-rigid systems (MGS, W-beam, or Thrie-beam guardrail) vary.
- Concrete (rigid) barriers are designed for virtually no deflection and may be used where space is limited between the obstacle and the travel lanes.

See the Roadside Design Guide (Ref. 9.1), Section 5.5.2, “Barrier Deflection Characteristics” for further information.

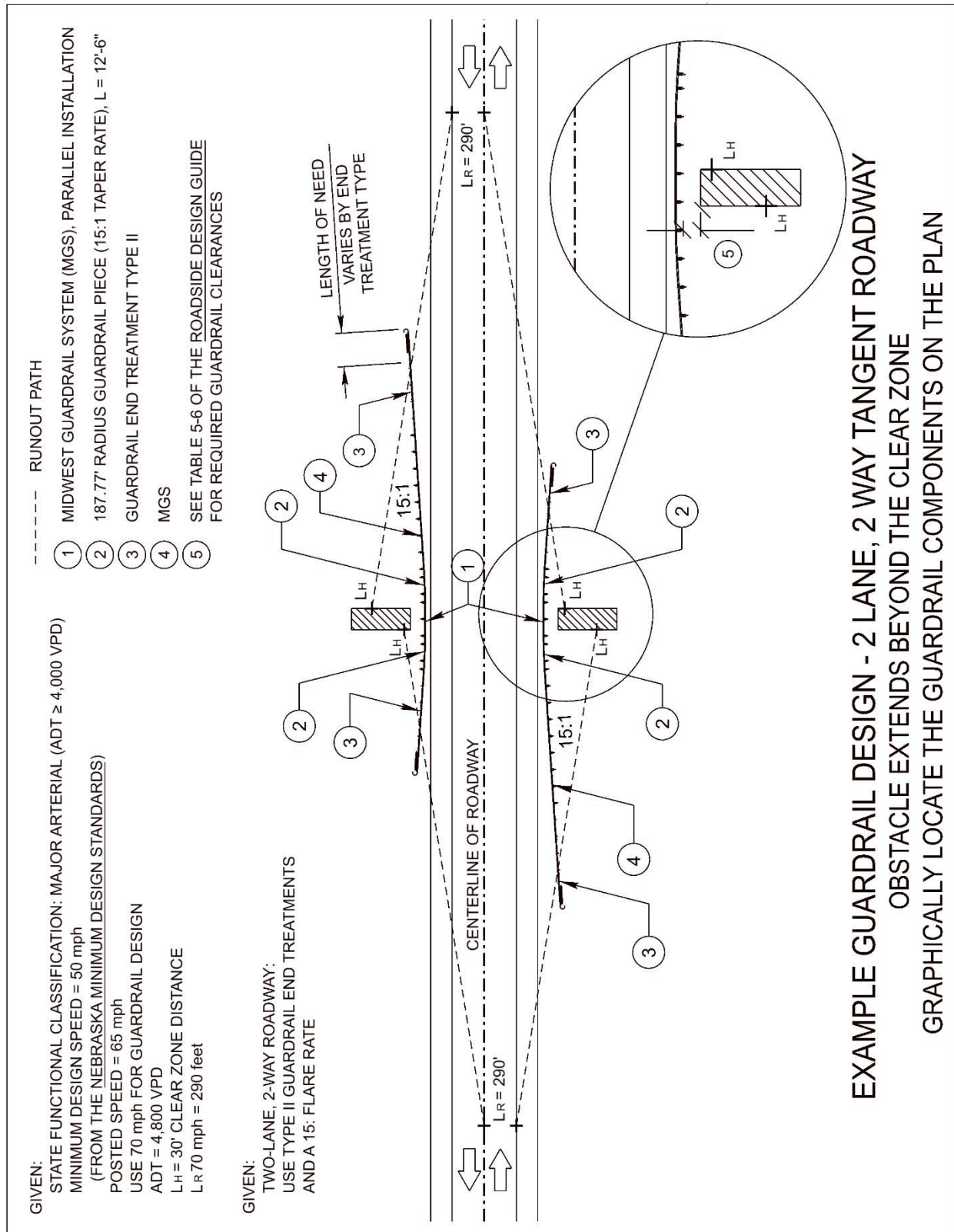
### 3.E Graphically Locate the Guardrail on the Plan

The designer should lay out the guardrail components on the plan (See EXHIBIT 9.6). For MGS, W-beam, and Thrie-beam installations, the components typically include the bridge approach section, the appropriate guardrail radius section for the design flare rate, the tangent guardrail section, and the applicable guardrail end treatment(s) (See Section 4 of this chapter). The runout path will intersect the guardrail, at a minimum, at the beginning of length of need point as specified by the end treatment’s manufacturer.

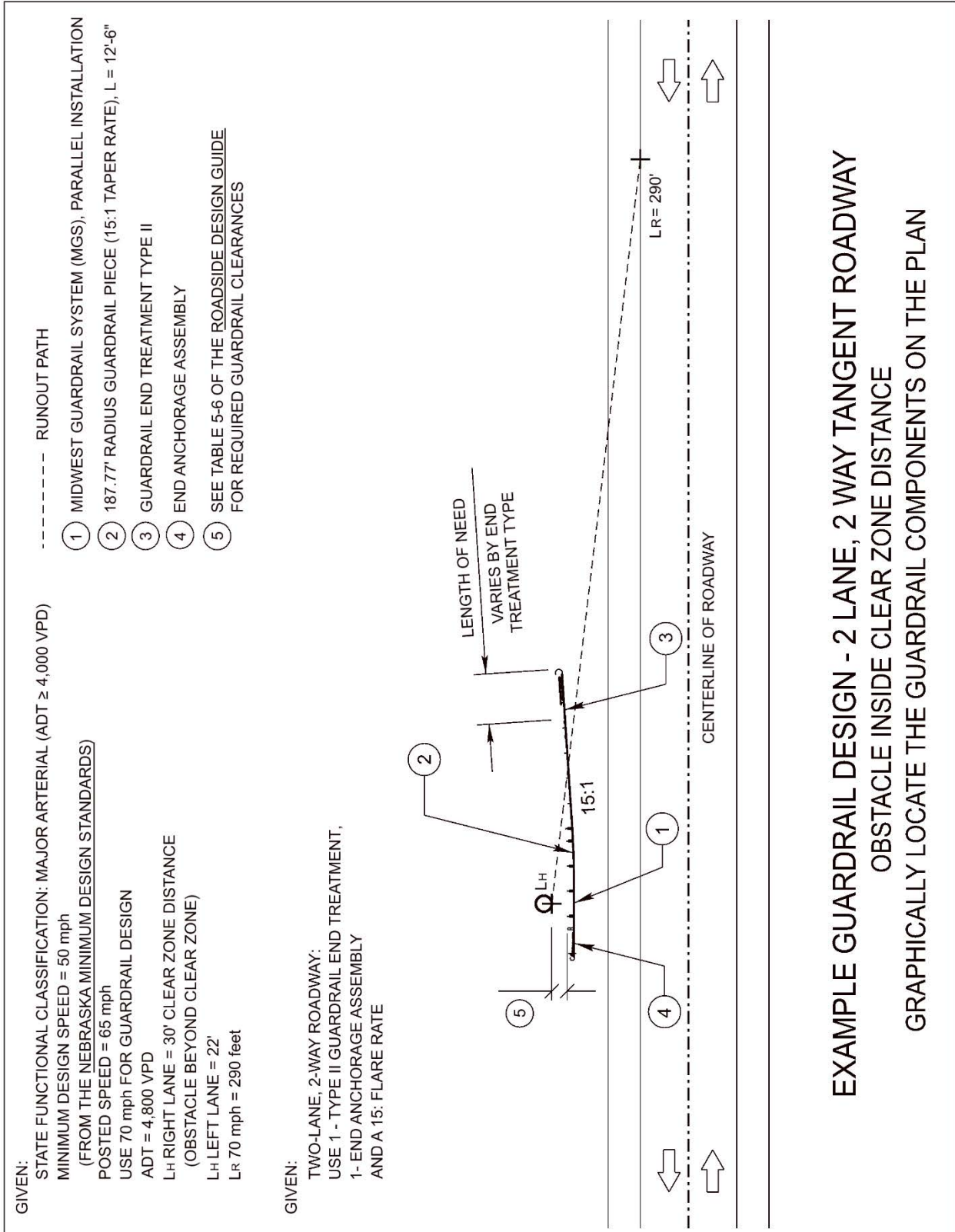
Cable guardrail installation components are the cable guardrail and the terminal anchorage sections. The runout path will intersect the low-tension cable guardrail at a distance of 15 feet or greater from the end of the in-line terminal anchorage section (See EXHIBIT 9.9).

For unique installations (e.g. on a curved roadway where the guardrail is curved in the opposite direction) the designer should provide the station and offset at the ends of the guardrail and at intermediate points as appropriate.

See the *Standard Plans* (Ref. 9.3) for details of the guardrail components.



**Exhibit 9.6a Graphically Locate the Guardrail Components on the Plan  
 (Obstacle Extends Beyond the Clear Zone Distance)**



**Exhibit 9.6b Graphically Locate the Guardrail Components on the Plan (Obstacle Inside Clear Zone Distance)**

### 3.F Design the Earthwork Around the Guardrail

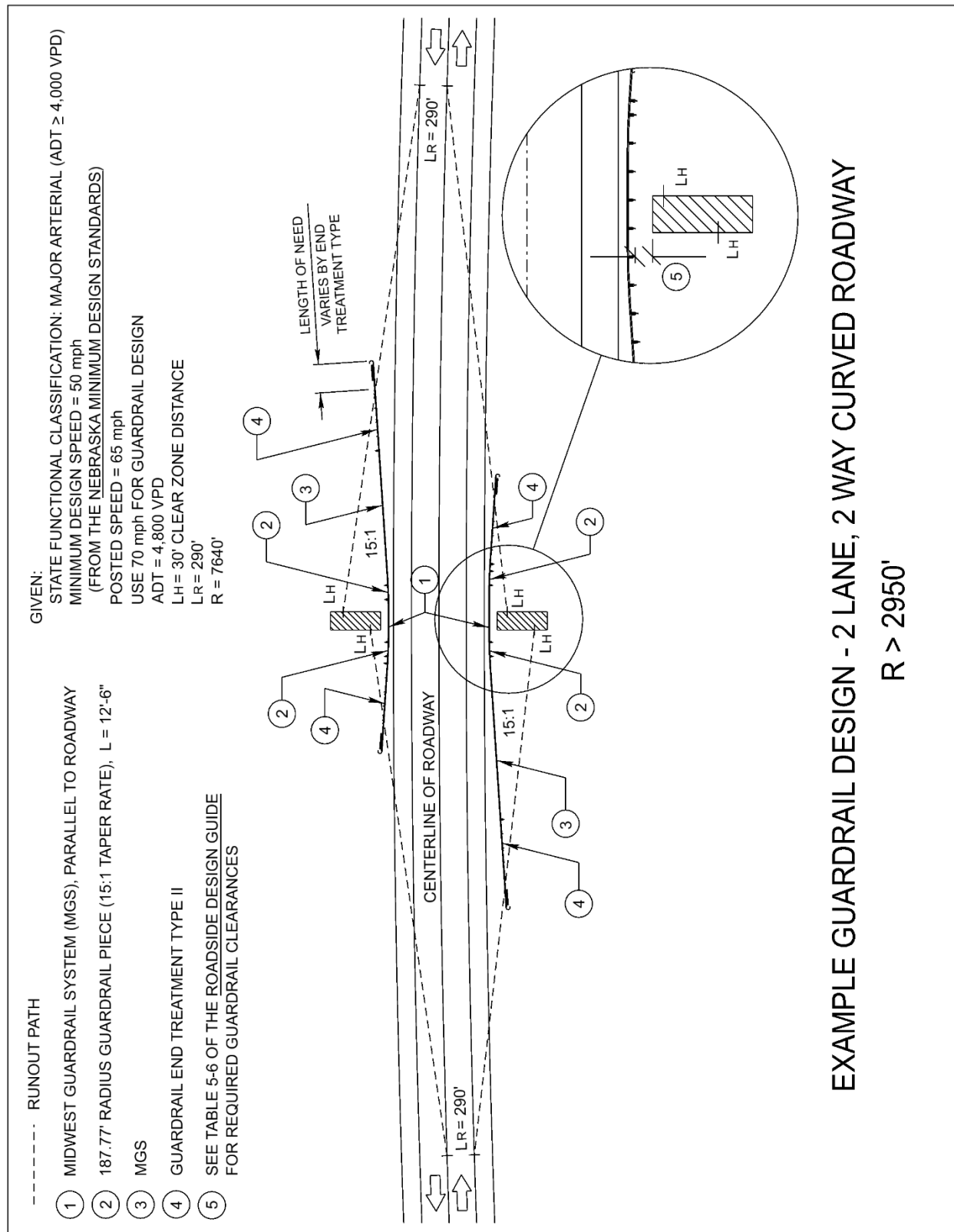
The designer should refer to the “Design Guides” section of the *Standard Plans* (Ref. 9.3) for guidance in designing earthwork for guardrail. Details of earthwork around the guardrail should be provided on guardrail plan sheets and on the project cross-sections for the benefit of the contractor and inspector (see Chapter Eleven: Highway Plans Assembly, of this manual). This earthwork will be included in the earthwork quantities.

### 3.G Determine the Details of Surfacing Under the Guardrail

Surfacing is placed under guardrail as a method to control weeds. The designer should consult with the **DE** or the **District Construction Engineer (DCE)** during the plan-in-hand field inspection to determine if surfacing under guardrail is desired, the choice of material to be used will be determined by the contractor. Surfacing may be concrete, asphaltic concrete, or millings. When concrete or asphaltic concrete surfacing is used the posts will be blocked out and backfilled with suitable materials (See the *Standard Plans* (Ref. 9.3), Standard Plan 743, and the Standard Specifications for Highway Construction (Spec Book) (Ref. 9.4) (<https://dot.nebraska.gov/media/g4qp4y0d/2017-specbook.pdf>).

Typical sections of asphalt surfacing under guardrail for non-curbed and curbed conditions are shown in Plan 1731 in the “Standard Details” section of the *Standard Plans* (Ref. 9.3). Designers will submit detailed plans, typical sections, and estimates for all asphalt surfacing under guardrail locations to the **Materials and Research Division (M&R)** for inclusion in the asphalt quantities; the designer is responsible for calculating concrete surfacing quantities.

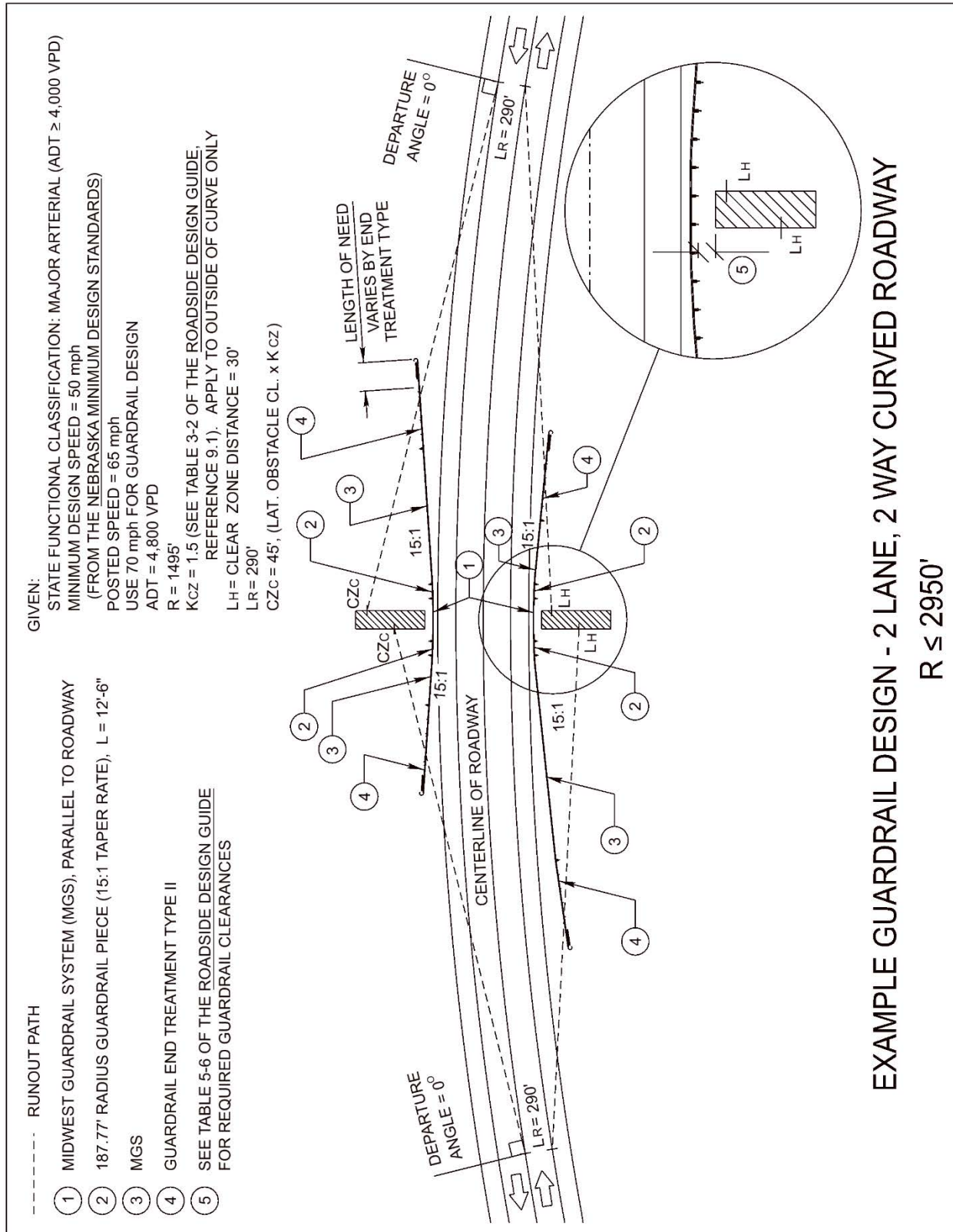
Further examples of typical guardrail installations may be found in EXHIBITS 9.7 THROUGH 9.9.



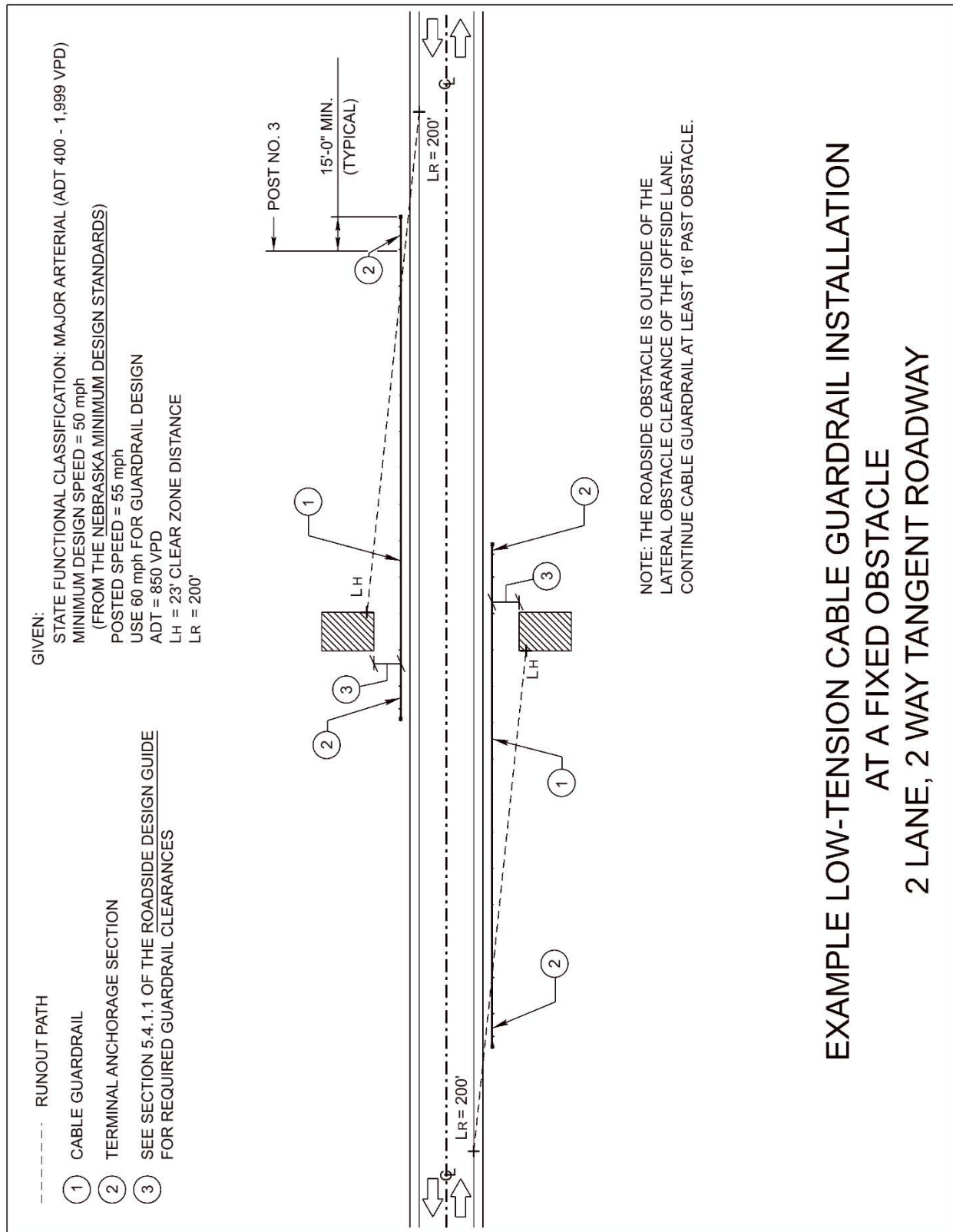
EXAMPLE GUARDRAIL DESIGN - 2 LANE, 2 WAY CURVED ROADWAY

$R > 2950'$

Exhibit 9.7 Example W-Beam or Thrie-Beam Guardrail Design:  
 2-Lane, 2-Way Curved Roadway:  $R > 2950'$



**Exhibit 9.8 Example W-Beam or Thrie-Beam Guardrail Design: 2-Lane, 2-Way Curved Roadway; R ≤ 2950'**



**Exhibit 9.9 Example Low-Tension Cable Guardrail Design:  
 2-Lane, 2-Way Tangent Roadway**



#### 4. END TREATMENTS

Guardrail end treatments used in Nebraska may be found in the Design Guides section of the *Standard Plans* (Ref. 9.3).

##### 4.A Guardrail End Treatment, Type I

A Guardrail End Treatment, Type I is Test Level 3 approved and is typically used for parallel guardrail installations or for installations with a 25:1 taper. This end treatment is used primarily for the Interstate System, freeways, and expressways.

##### 4.B Guardrail End Treatment, Type II

A Guardrail End Treatment, Type II is Test Level 3 approved and is primarily installed on high-speed ( $\geq 50$  mph) two-lane, two-way roadways with a guardrail installation with a 15:1 taper.

##### 4.C Guardrail End Treatment, Type TL2 (for Low-Speed Roadways)

The Guardrail End Treatment, Type TL2 is Test Level 2 approved and is installed on low-speed ( $\leq 45$  mph) two-lane, two-way roadways with guardrail installations, typically with a 25:1 taper. The minimum guardrail installation at a low-speed bridge connection consists of the Guardrail End Treatment, Type TL2 connected directly to a Bridge Approach Section, Type TL2. See the *Standard Plans* (Ref. 9.3) for details.

##### 4.D End Anchorage Assembly

The end anchorage assembly is permitted on the trailing ends of guardrail installations that are not exposed to oncoming traffic and on curved beam guardrail installations (with control releasing terminal posts) terminating on driveways to provide tension to the guardrail system. See the *Standard Plans* (Ref. 9.3), Standard Plan 745, for details.

##### 4.E Bullnose

See Section 6.B of this chapter.

#### 5. BRIDGE APPROACH SECTIONS

The bridge approach section is a transition section used where semi-rigid guardrail joins to a rigid bridge rail. Transition sections are designed to produce a gradual transition between the deflection capabilities of the two types of rail, reducing the potential of a vehicle pocketing, snagging, or penetrating the rail in the transition area. The bridge approach sections for both high-speed installations ( $\geq 50$  mph, 25 feet in length) and low-speed installations ( $\leq 45$  mph, 9 feet - 4.5 inches in length) in Nebraska may be found in the *Standard Plans* (Ref. 9.3). For examples of typical guardrail installations at a bridge, see EXHIBITS 9.10 THROUGH 9.12 AND EXHIBITS 9.15 & 9.16.

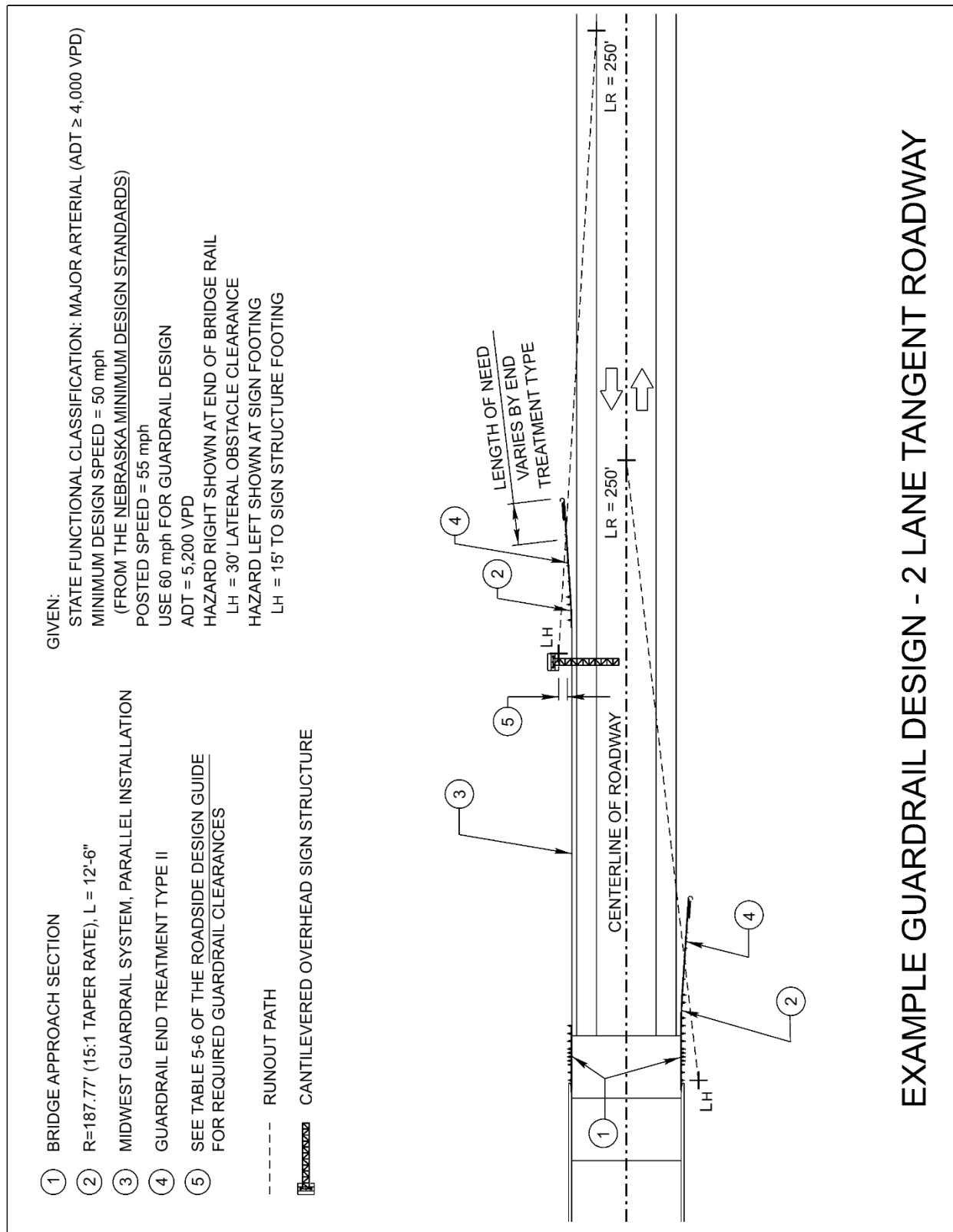


Exhibit 9.10 Example Guardrail Design at a Bridge:  
 2-Lane, 2-Way Tangent Roadway

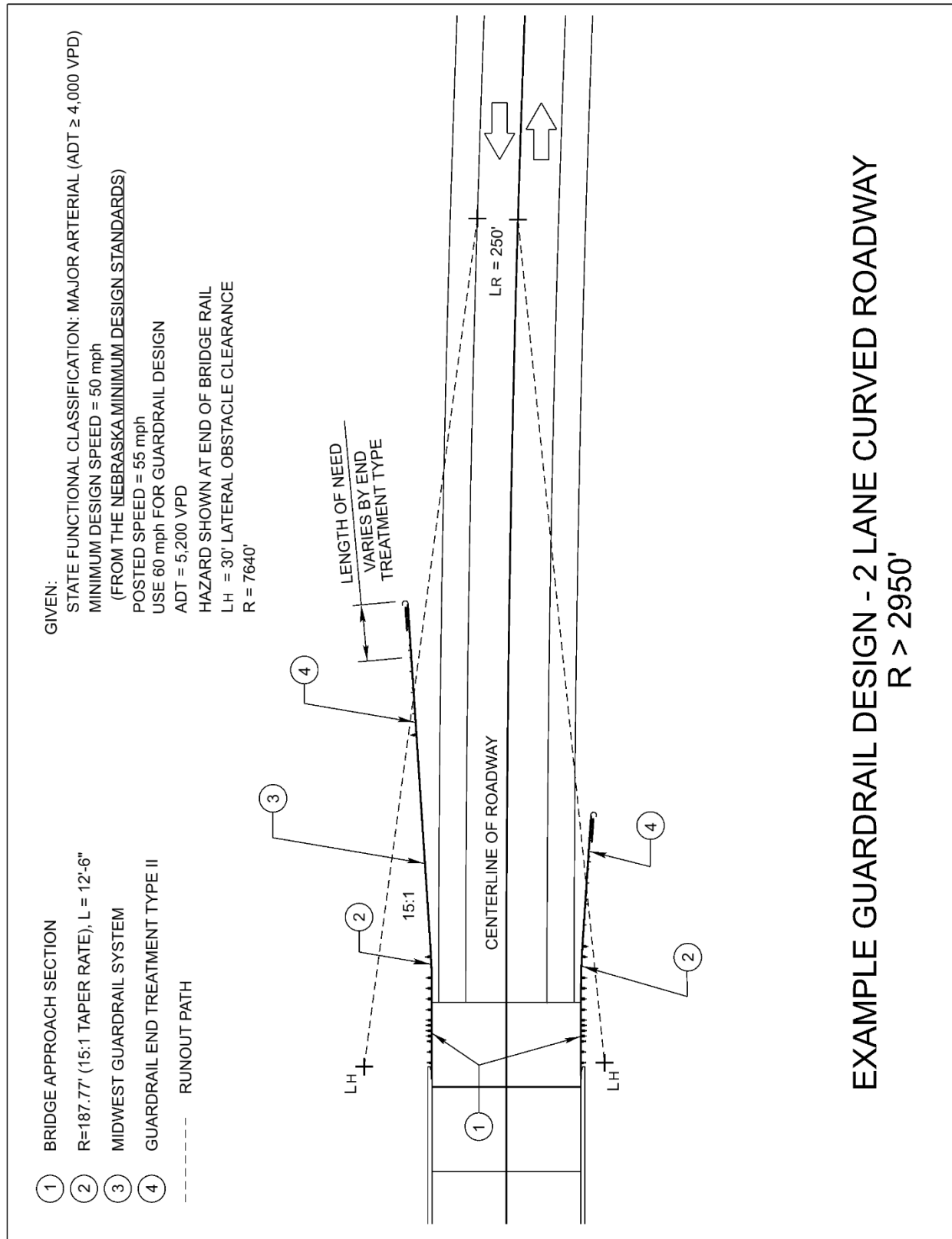


Exhibit 9.11 Example Guardrail Design at a Bridge:  
 2-Lane, 2-Way Curved Roadway; R > 2950'

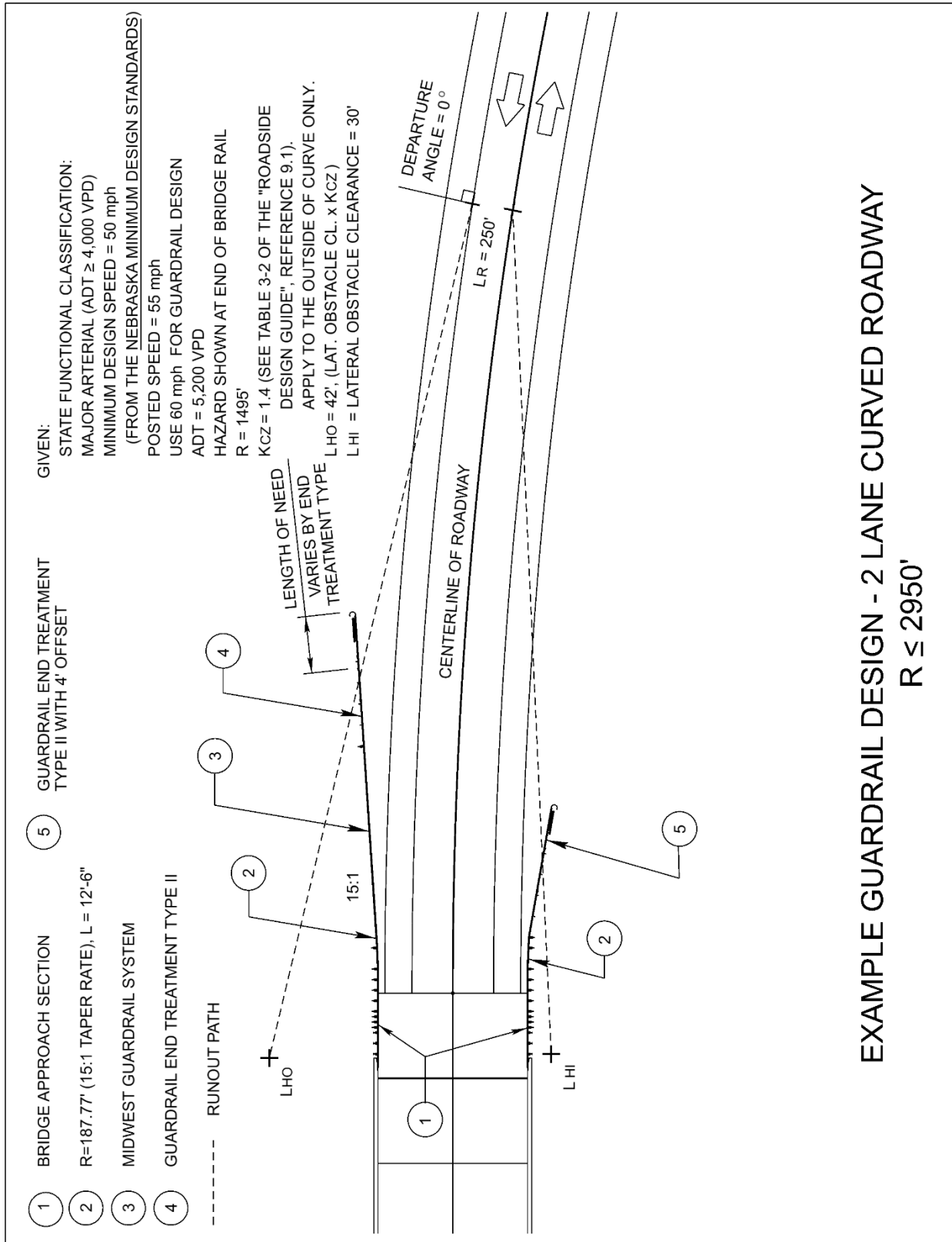


Exhibit 9.12 Example Guardrail Design at a Bridge:  
 2-Lane, 2-Way Curved Roadway; R ≤ 2950'

## 6. MEDIAN BARRIERS

A barrier is placed in the median of a divided highway to reduce crossover head-on crashes and to redirect vehicles striking from either side of the barrier. The design, height, and lateral placement of the median barrier is critical for proper performance.

- 1) **NDOT** follows the guidance found in Chapter 6 of the Roadside Design Guide (Ref. 9.1).
- 2) EXHIBIT 9.13 Presents Benefit/Cost ratios for the installation of cable guardrail median barriers in relatively flat, unobstructed medians. These criteria may be used in the absence of cross median crash data for a specific site.
- 3) EXHIBIT 9.14 presents guidelines for median barrier installations on high-speed controlled access roadways that have relatively flat, unobstructed medians. These criteria may be used in the absence of cross median crash data for a specific site.
- 4) For median widths between 30 feet and 50 feet, **NDOT** will analyze the crash history and determine if median barrier installation is warranted.

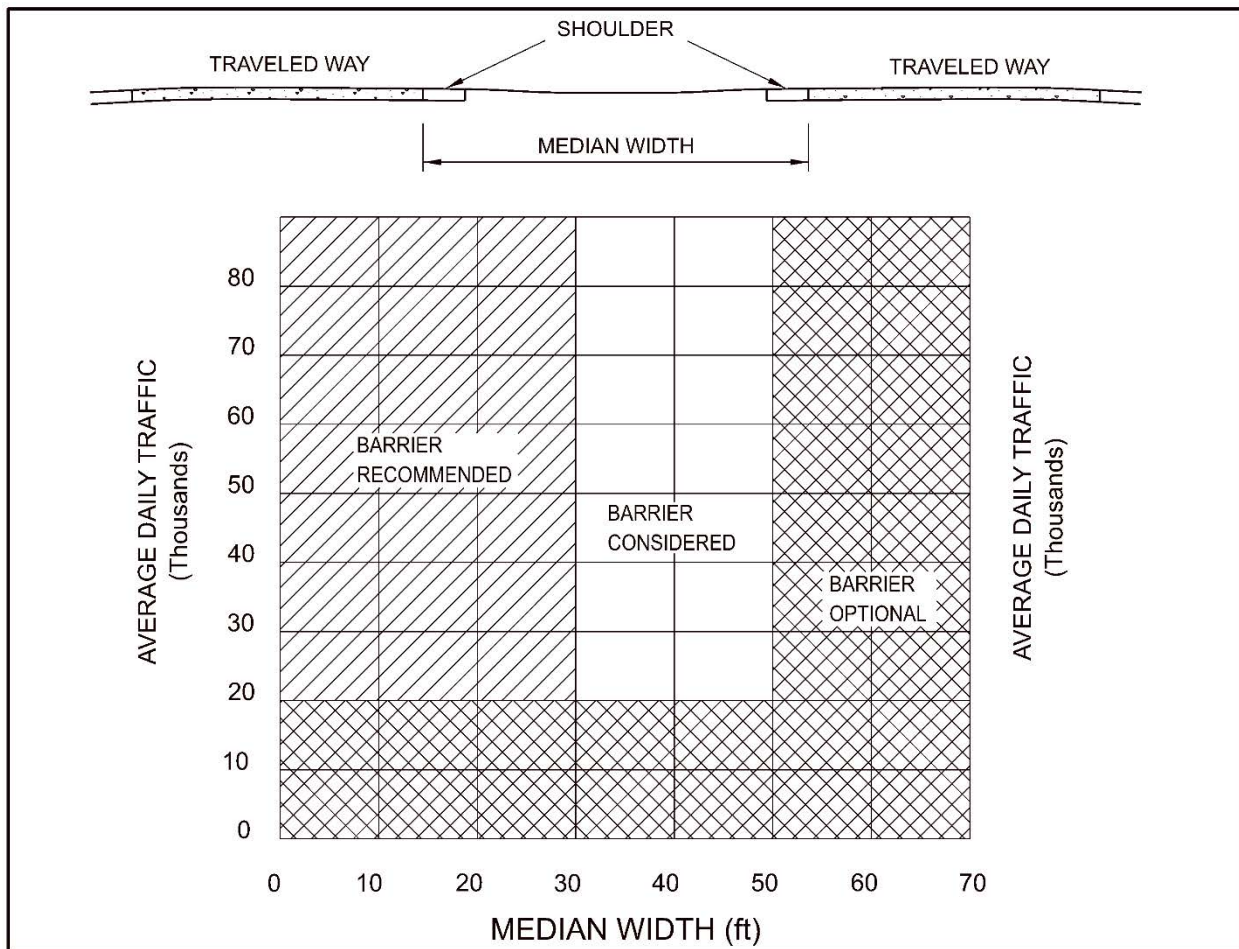
Median Width (ft.)	Traffic Volume at B/C =2.0 (1000 ADT)	Traffic Volume at B/C = 4.0 (1000 ADT)
10	15	17
20	19	22
30	24	28
40	31	37
50	42	51
60	60	74
70	97	121

Traffic Volumes are based on two-way traffic.

Cable barrier should be installed at a B/C ratio of 4.0 and above, may be considered at B/C ratios between 2.0 and 4.0, and is generally not cost effective at a B/C ratio below 2.0.

For additional information, refer to the Cable Median Barrier Guidelines at <https://mwrsf.unl.edu/researchhub/files/Report75/TRP-03-206-08.pdf>

### Exhibit 9.13 Cable Barrier B/C Ratios



**Exhibit 9.14 Guidelines for Median Barriers**  
 Source: Roadside Design Guide (Ref. 9.1)

**6.A Median Barrier Systems**

**Concrete Protection Barrier**

The concrete protection barrier (32 inch or 42 inch) should be used in narrow flush medians, depending upon the traffic speed, ADT, and percentage/number of heavy truck traffic and the crash history. Both the 32 inch and 42 inch heights provide for a future three-inch overlay to be placed against the barrier. Concrete median barriers may be precast or cast in place. The barrier ends should be treated with an appropriate terminal section or tapered away beyond the clear zone. See the *Standard Plans* (Ref. 9.3), Standard Plan 870, for details.

### **Semi-Rigid Guardrail**

Guardrail may be installed in the median to deflect vehicles from hitting specific obstacles, such as piers, and at dual bridges on divided highways. The preferred installation at a bridge in a median with a width of 40 feet or greater may include a bridge approach section, MGS, W-Beam, or Thrie-Beam guardrail, and a guardrail end treatment (See Section 4.A of this chapter and [EXHIBITS 9.15 & 9.16](#)).

The preferred installation for pier protection in a median with a width of 40 feet or greater will consist of two parallel runs of semi-rigid guardrail with one guardrail end treatment and one end anchorage assembly each, located so that the back of the end treatments are beyond the clear zone of the opposing traffic (See [EXHIBIT 9.17](#)). The **District** may want surfacing under the guardrail for weed control.

### **Cable Guardrail**

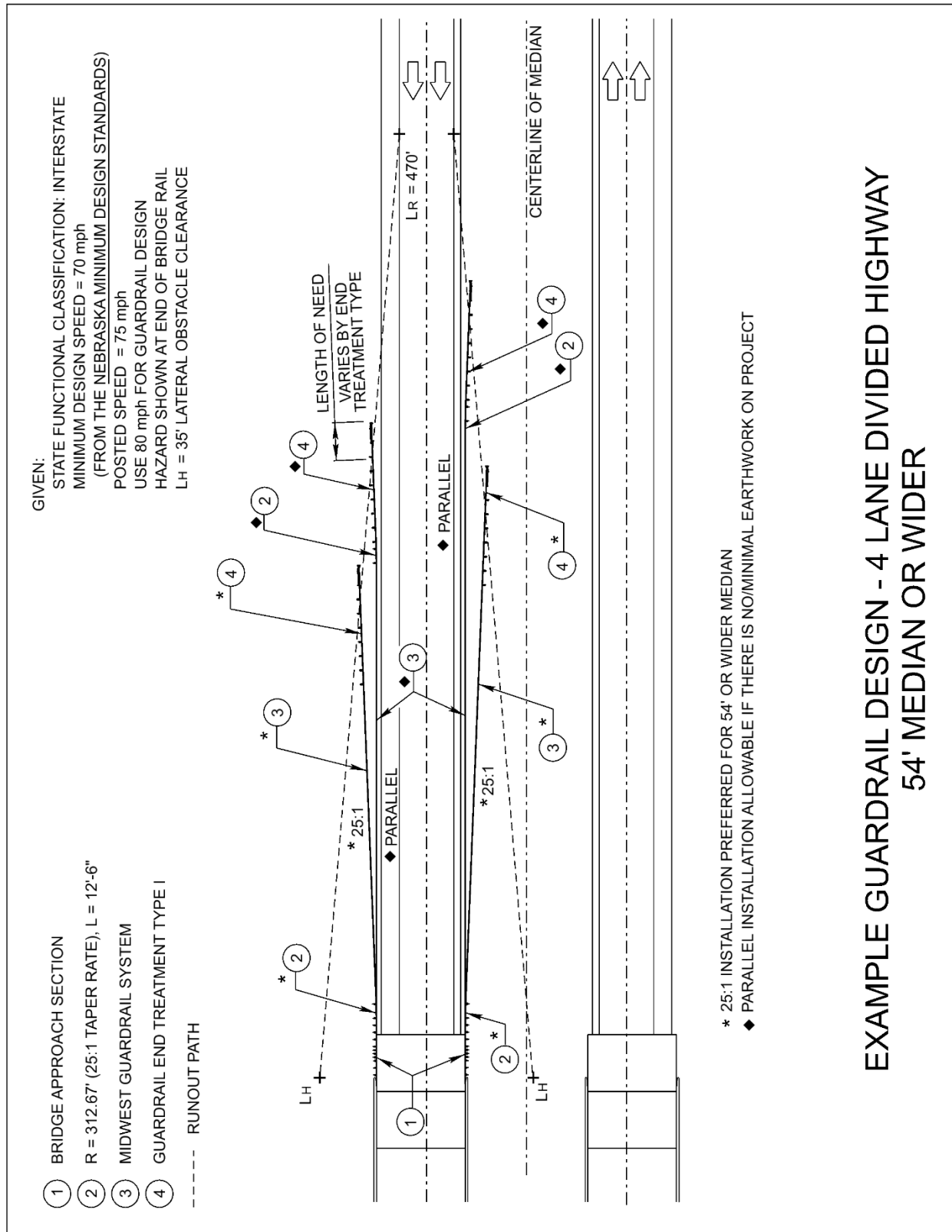
Cable guardrail may be installed in medians which are of sufficient width to allow for the greater deflection of the cable, 12 feet for a low-tension installation. Crash tests on high-tension cable guardrail systems have exhibited reduced deflection distances, as specified by the manufacturer. The installation of high-tension cable guardrail requires **Roadway Design Engineer** approval.

### **Bullnose**

The bullnose guardrail installation may be used on multilane divided highways to protect the motorist from hitting sign bases, bridge ends, bridge piers, or other obstacles in the median or gore area (See [EXHIBIT 9.18](#)).

When a bullnose installation is used to protect bridge ends in medians of 40 feet or less in width some **Districts** prefer to connect the bullnose installation to both of the paired parallel bridges; other **Districts** prefer the away side to be unattached so that maintenance has easy access for mowing behind the bullnose. The designer should contact the **DE** or **DCE** to ascertain the preferred installation method (See [EXHIBITS 9.19 THROUGH 9.23](#) for design examples).

Bullnose attenuators are designed so that the front end of vehicles impacting the installation head-on will be wrapped by the guardrail and will decelerate to a stop; side-impacting vehicles will be redirected. The bullnose installation shall have a minimum 66 feet of clearance from the tip of the bullnose to the fixed object. The approaching terrain should be unobstructed and graded 1:10 or flatter for a minimum of 60 feet prior to and under the bullnose for proper performance (See the *Standard Plans*, Ref. 9.3, Standard Plans 712 & 713).



**Exhibit 9.15 Example Guardrail Design – 4 Lane Divided Highway:  
 54 Foot and Wider Median Width**



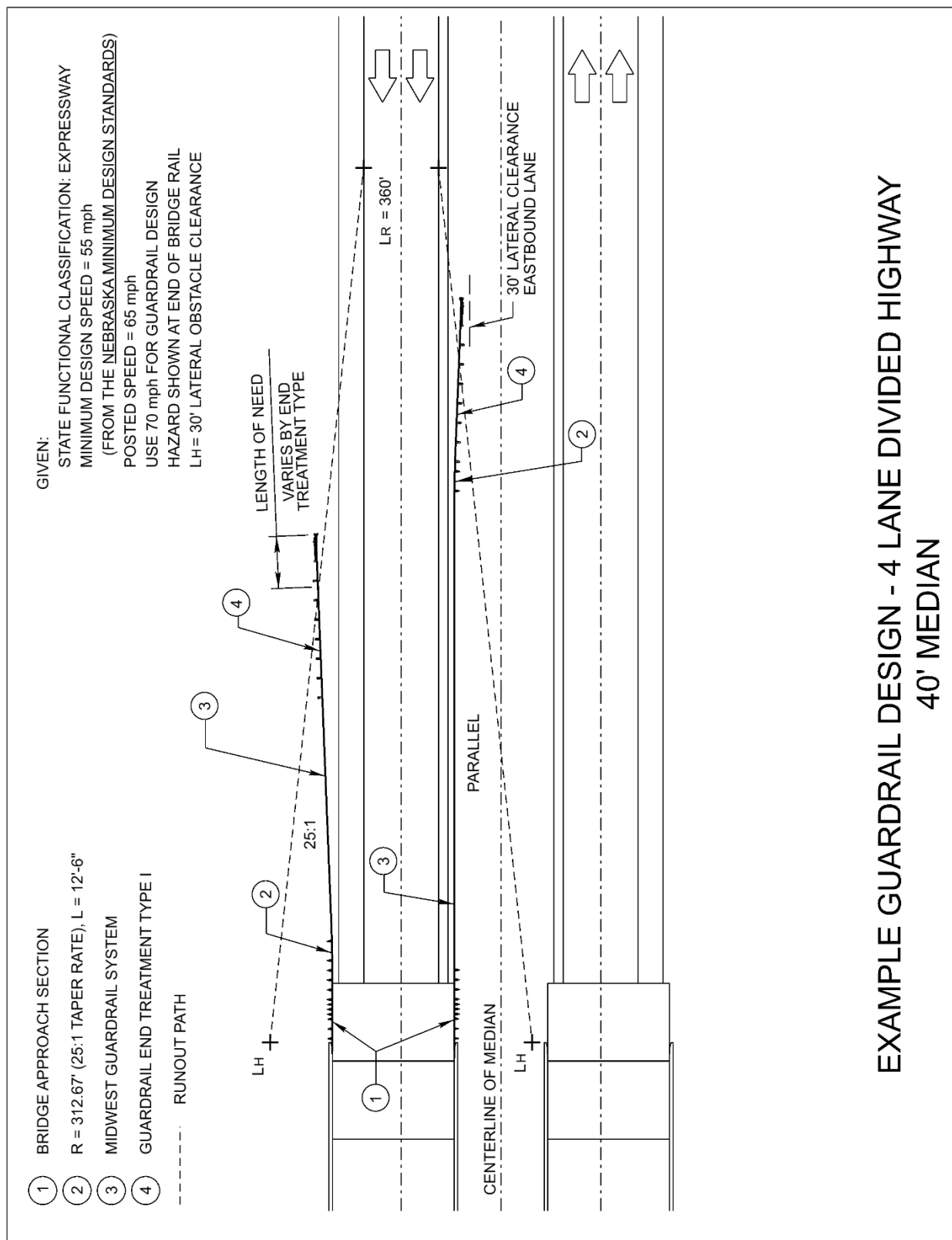
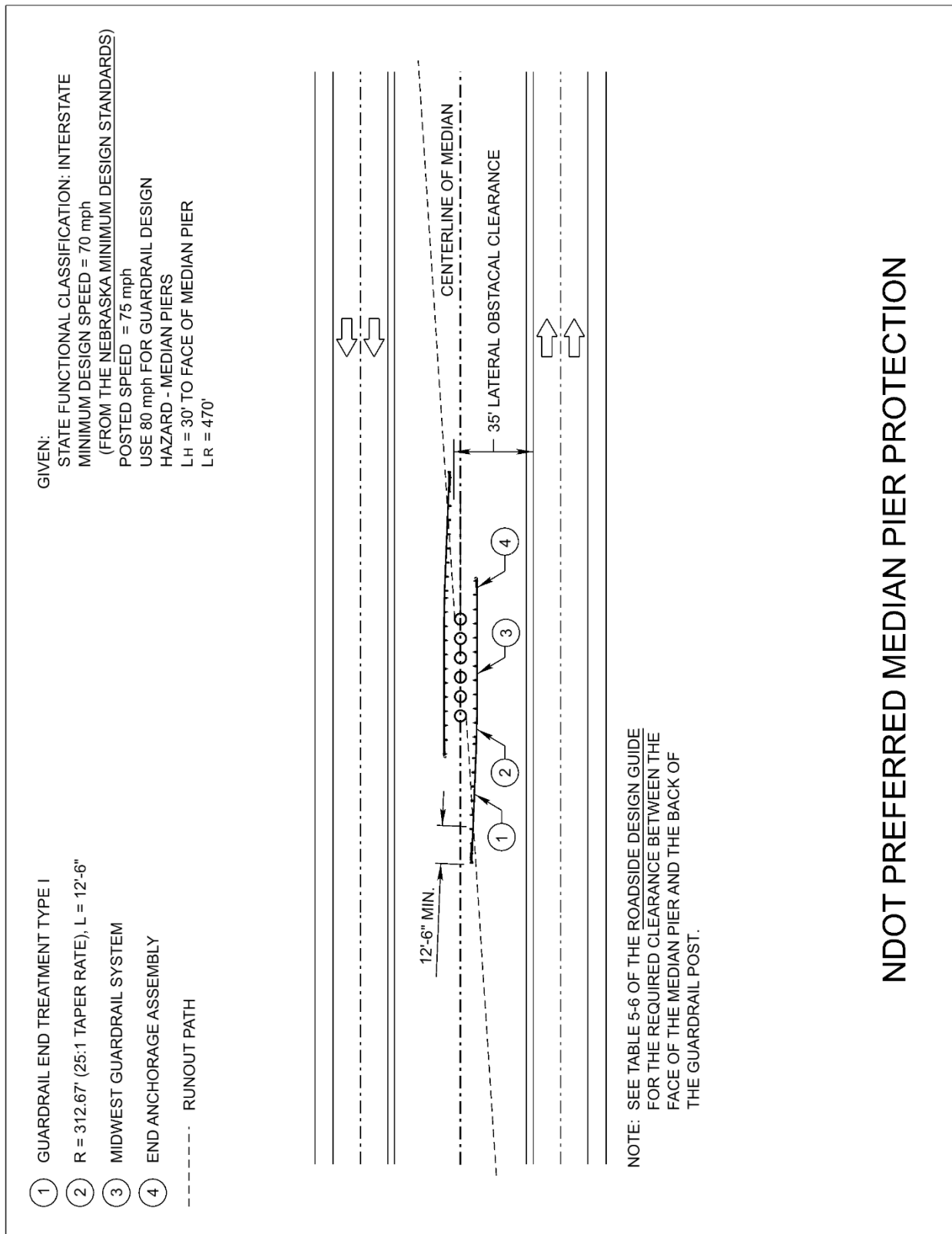


Exhibit 9.16 Example Guardrail Design – 4 Lane Divided Highway:  
 40 Foot Median Width



**Exhibit 9.17 Example Pier Protection Guardrail Design – 4 Lane Divided Highway: 40 Foot and Wider Median Width**

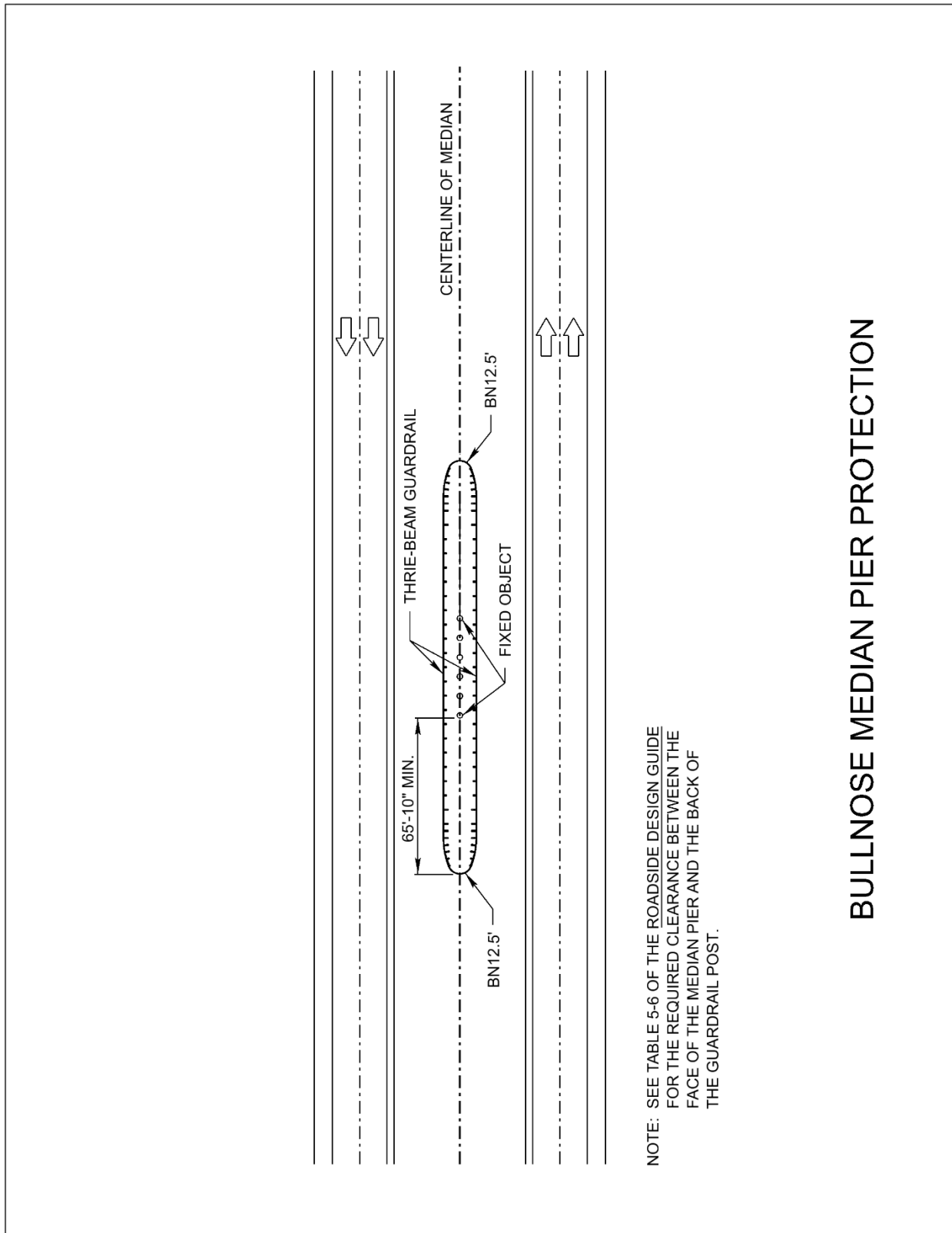
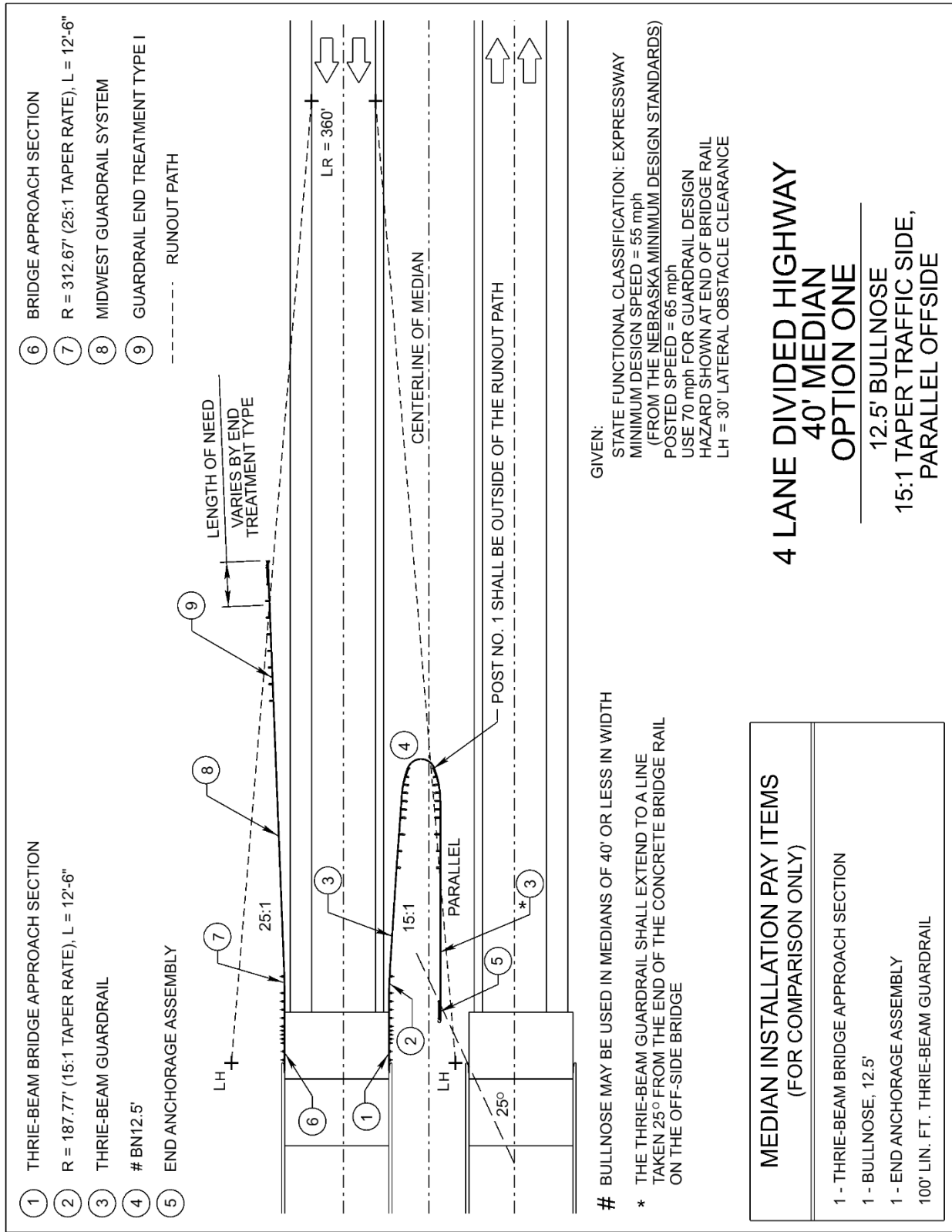
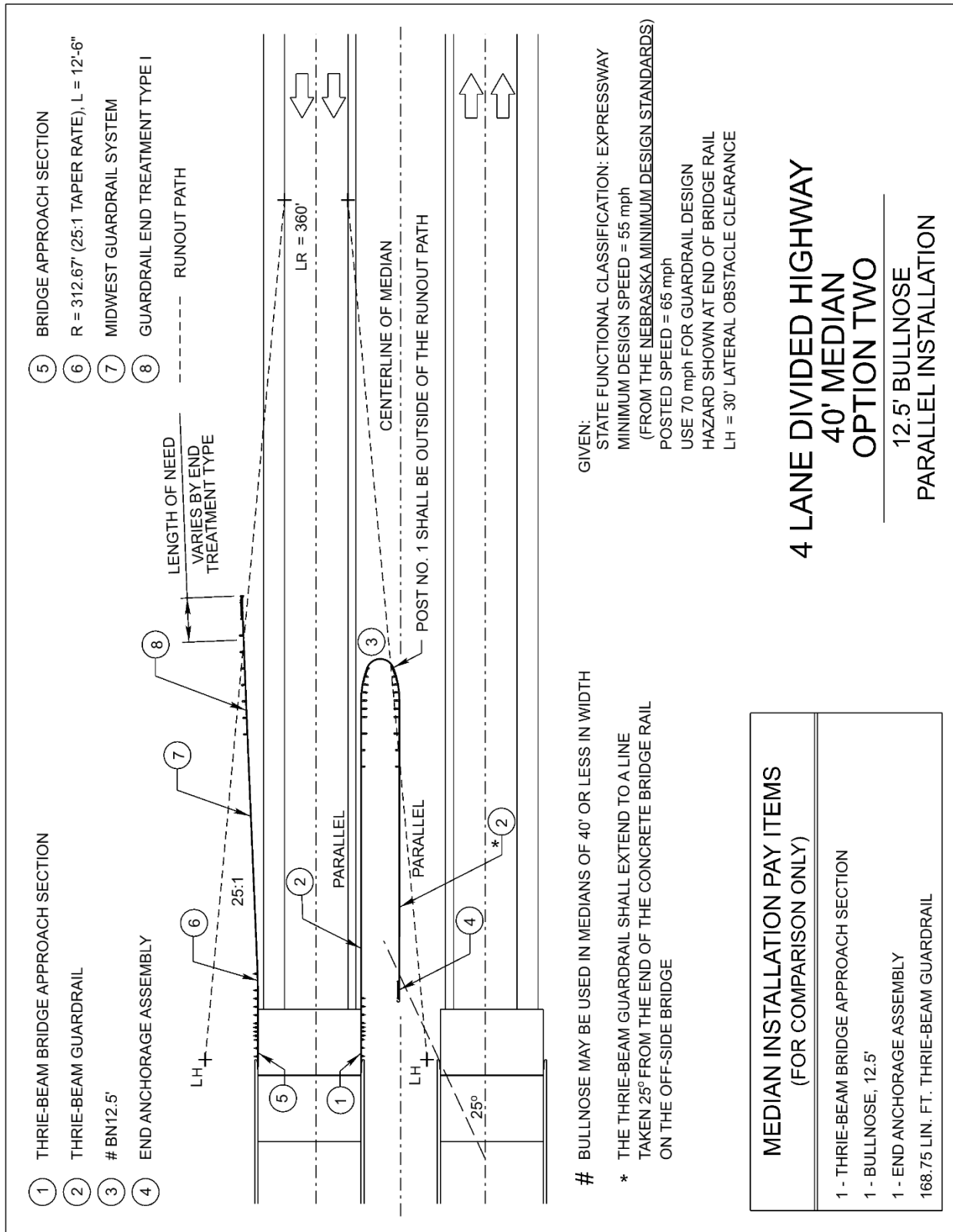


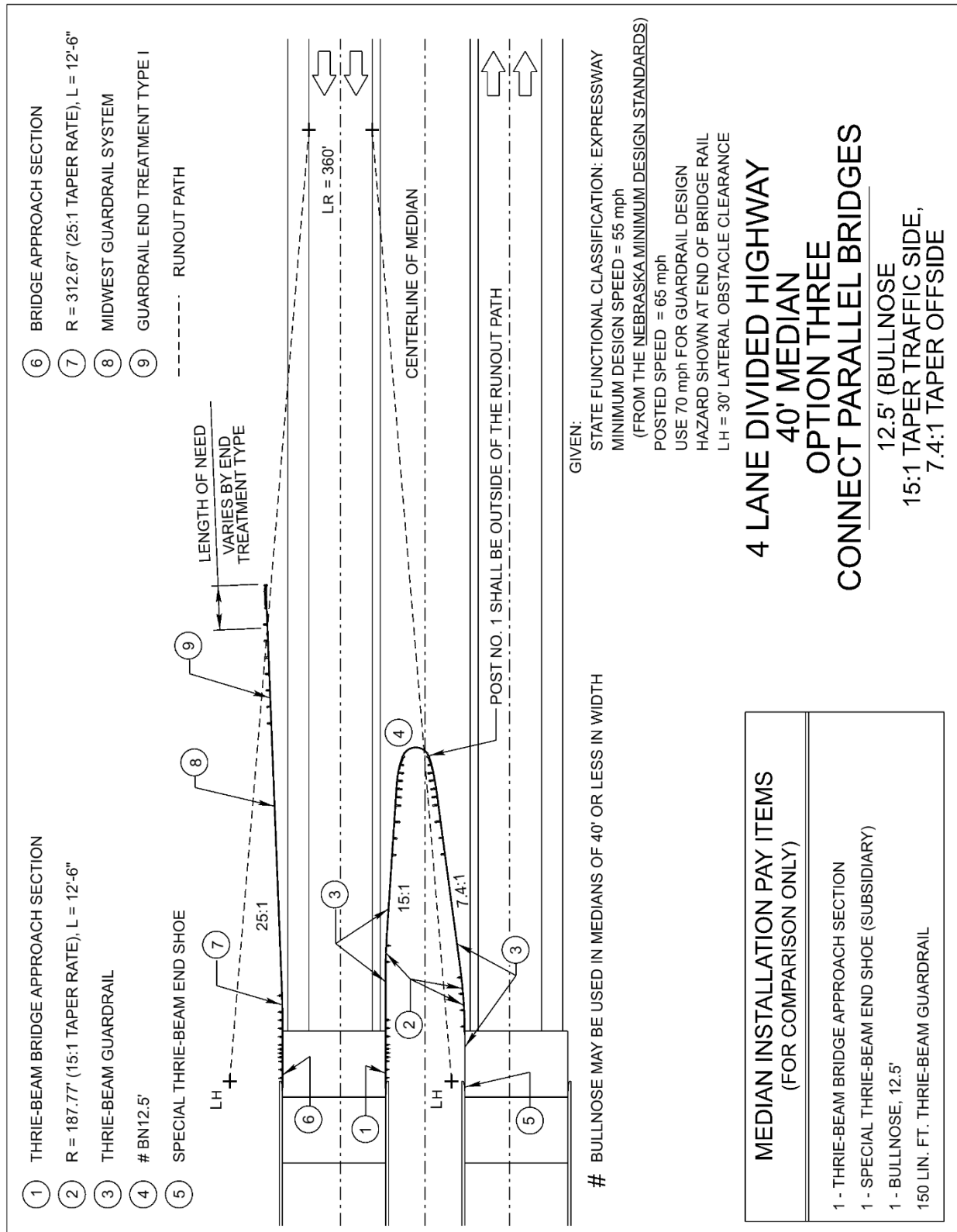
Exhibit 9.18 Example Bullnose Installation for Median Bridge Pier Protection



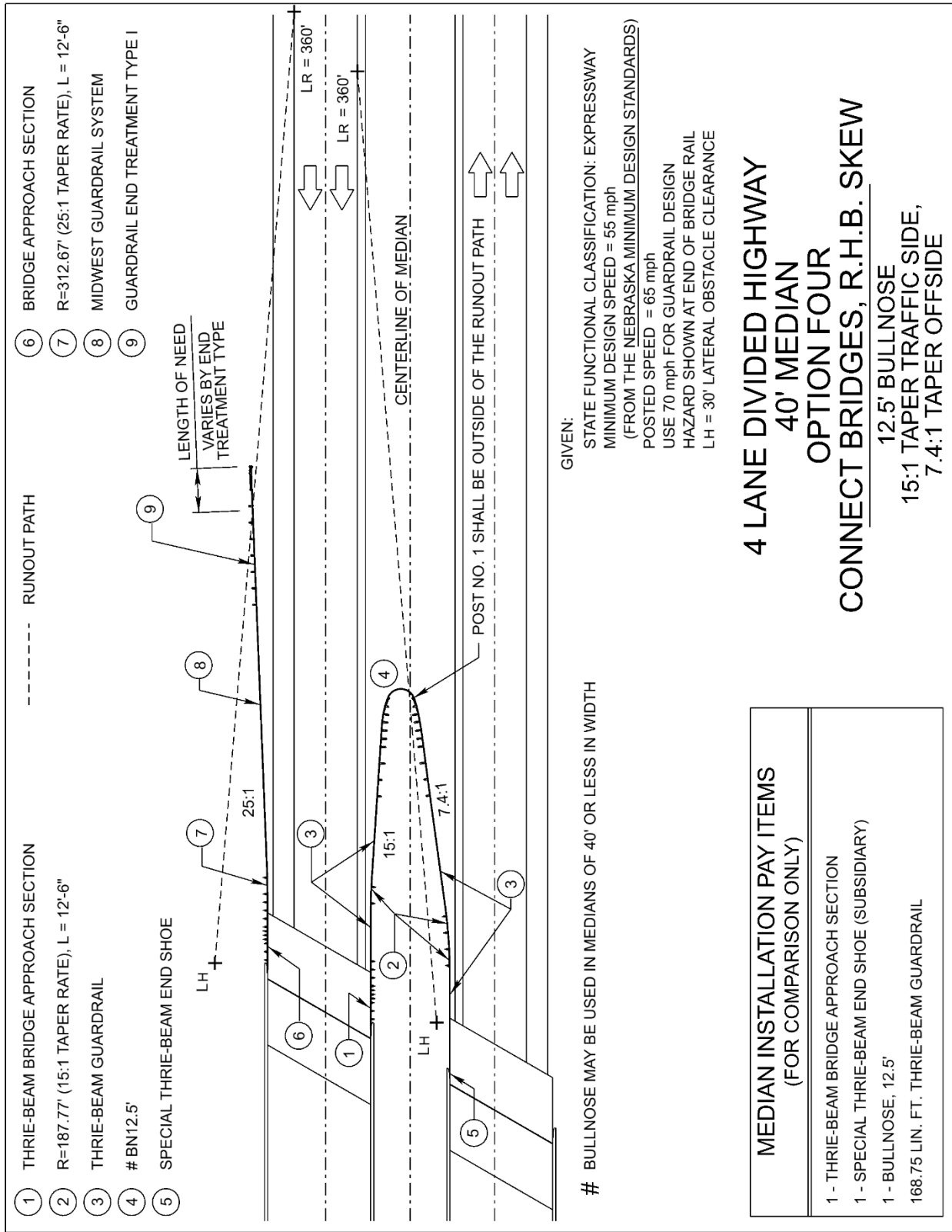
**Exhibit 9.19 Example Bullnose Bridge Connection in a 40 Foot Wide Median:  
 Tapered Bullnose, Bridges not Connected**



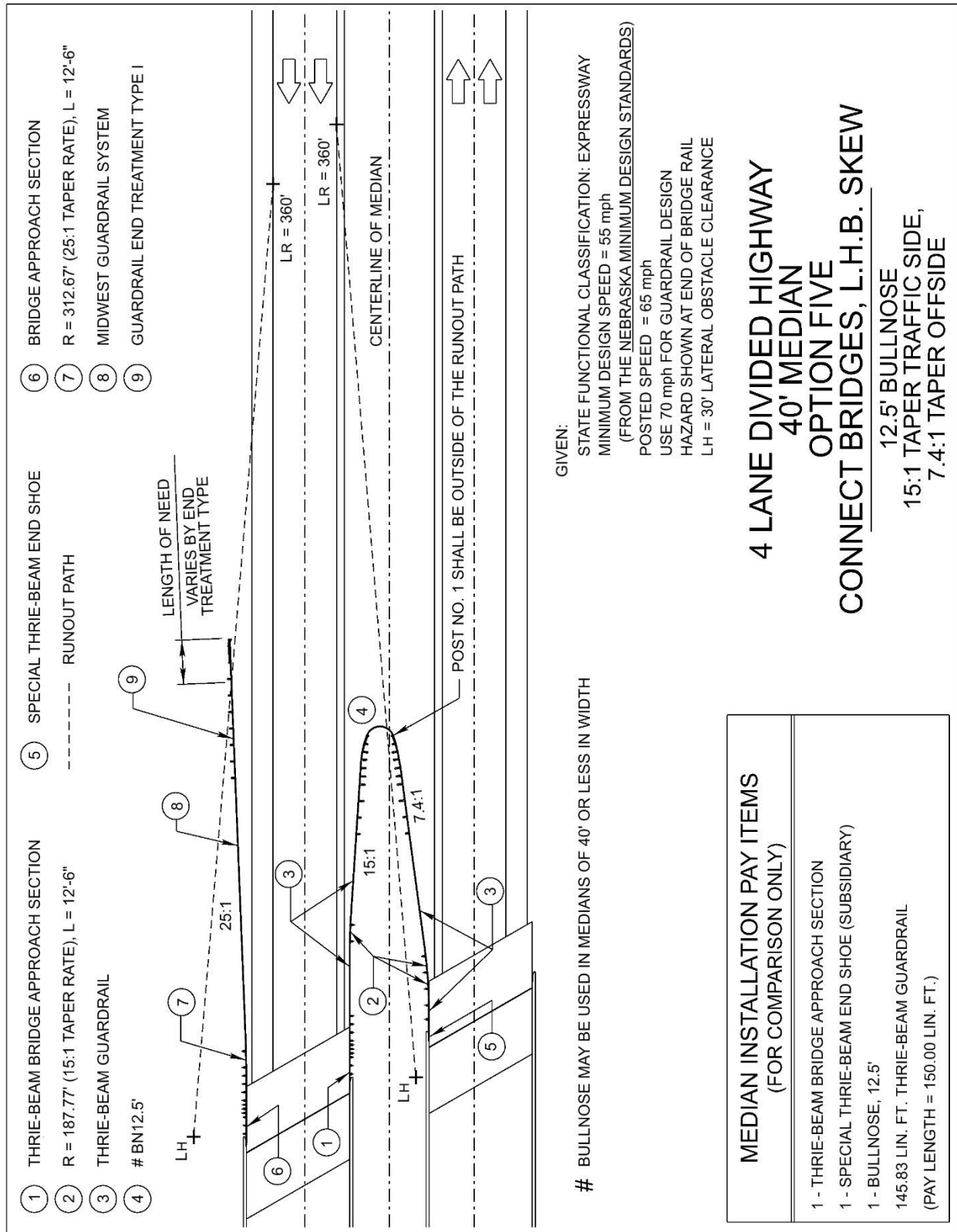
**Exhibit 9.20 Example Bullnose Bridge Connection in a 40 Foot Wide Median: Parallel Bullnose, Bridges not Connected**



**Exhibit 9.21 Example Bullnose Bridge Connection in a 40 Foot Wide Median:  
 Tapered Bullnose, Bridges Connected**



**Exhibit 9.22 Example Bullnose Bridge Connection in a 40 Foot Wide Median:  
 Right-Hand-Back Skew, Tapered Bullnose, Bridges Connected**



**Exhibit 9.23 Example Bullnose Bridge Connection in a 40 Foot Wide Median:  
 Left-Hand-Back Skew, Tapered Bullnose, Bridges Connected**



## 7. SPECIAL INSTALLATIONS

### 7.A Guardrail at Intersections

When a minor road or driveway intersects a main roadway near a bridge it may not be possible to shield the bridge rail end with a standard guardrail installation. If it is not feasible to relocate the intersecting road, a crash cushion or an impact attenuator could be installed to protect the end of the bridge rail or a short radius W-Beam guardrail installation may be used with **Roadway Design Unit Head** approval. An area behind the guardrail, based on the radius of the curved beam, should be free of fixed objects. The standard bridge approach section or bridge approach section Test Level 2 (on low-speed roadways,  $\leq 45$  mph) should be used to transition to a concrete bridge rail. Controlled releasing terminal (CRT) posts are used through the curved section. Low-speed guardrail end treatments (See Section 4.C of this chapter) may be used for the terminal on the minor road, an end anchorage assembly may be used for the terminal on driveways, and a guardrail end treatment or a Test Level 2 guardrail end treatment should be used for the terminal on state highways. See the "Standard Details" section of the *Standard Plans* (Ref. 9.3), Plan 7046, for an example of this design and for plans of the guardrail components. Further information may be found in the Roadside Design Guide (Ref. 9.1).

### 7.B Guardrail Over Low Fill Culverts

The *Standard Plans* (Ref. 9.3), Standard Plans 747 & 748, illustrates the culvert mounted guardrail post details to be used when full embedment of a guardrail post is not possible, such as over low-fill culverts. Designers should graphically lay out the guardrail post location to use the minimum number of special posts. Posts can be attached directly to the top of the Concrete Box Culvert or to the face of the parapet.

### 7.C Guardrail Spans with Posts Eliminated

The "Standard Details" section of the *Standard Plans* (Ref. 9.3), Plan 7049, illustrates the MGS design to be used for long spans of two missing posts (up to 25 feet) where guardrail posts are eliminated, such as over low fill culverts or in places where two or three posts cannot be placed; three breakaway wood posts are placed on each side. Where a single guardrail post cannot be placed it may be skipped (12.5 foot gap between posts) with no other change; MGS W-Beam does not need to be nested.

**7.D MGS Installed Near Slopes**

While MGS should be installed on slopes of 1:10 or flatter, there are circumstances where installing guardrail near a steeper slope may be warranted. Currently four W-beam guardrail configurations installed near slopes have been successfully crash tested to MASH Test Level 3 (See EXHIBIT 9.24). All four configurations utilize a 31 inch tall guardrail, a 6.25 foot post spacing, and should be limited to slopes of 1:2 or flatter.

<p><b>Installation Type A</b></p>	<p><b>Installation Type B</b></p>	<p><b>Installation Type C</b></p>	<p><b>Installation Type D</b></p>
<p>Installed adjacent to the slope using:</p> <ul style="list-style-type: none"> <li>• 9 foot long posts centered on the slope break point</li> <li>• 12 inch blockouts (8 inch and no blockouts are acceptable options)</li> </ul>	<p>The only system with the posts installed on the slope using:</p> <ul style="list-style-type: none"> <li>• 8 foot long posts placed at 12 inches to the face of the post down a 1:2 slope (placing the face of the guardrail at the slope break point)</li> <li>• 8 inch blockouts (12 inch blockouts may be used)</li> </ul>	<p>Developed specifically for use on top of MSE walls using:</p> <ul style="list-style-type: none"> <li>• Standard 6 foot long posts which extend through the mesh, strengthening the system</li> <li>• No blockouts</li> </ul>	<p>A standard MGS installation with</p> <ul style="list-style-type: none"> <li>• 6 foot long posts centered on the slope break point</li> <li>• 12 inch blockouts (8 inch and no blockouts are acceptable options)</li> </ul> <p>This installation exhibits greater deflection than the other installations.</p>

**Exhibit 9.24 Details for 31 inch MGS Near Slopes**

(Source: Adapted from A Synthesis of MASH Tested 31-in. Tall, Non-Proprietary, W-Beam Guardrail Systems, Transportation Research Board, October 2017)

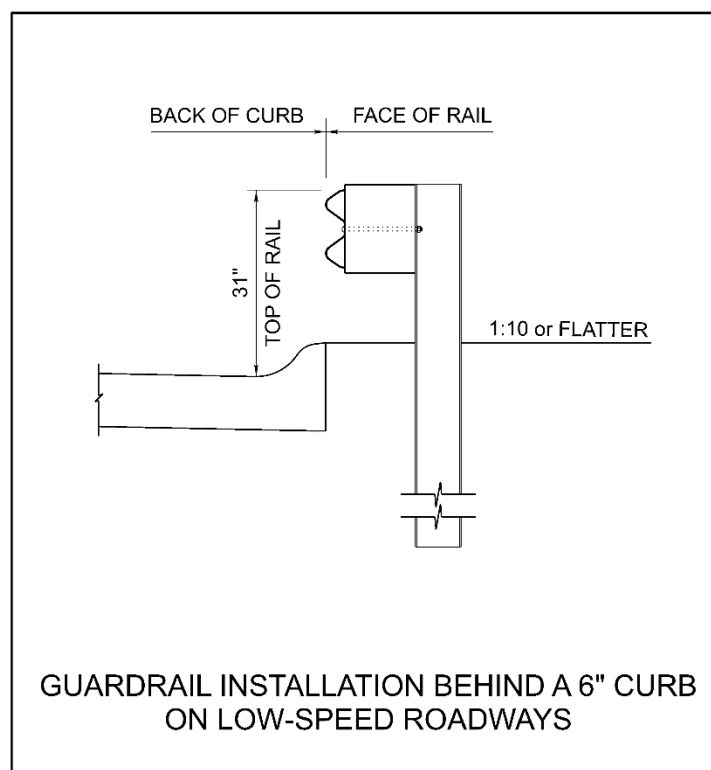
### 7.E Guardrail and Curbs

If a curb is used in conjunction with a guardrail installation on a high-speed facility ( $\geq 50$  mph), the curb will be either a three-inch or four-inch concrete slope curb or a three-inch asphaltic concrete mountable curb. The desirable curb location will place the back of the curb a minimum distance of two feet behind the back of the guardrail post. If curb must be placed in front of a guardrail installation, the back of the curb should be flush with the front face of the guardrail posts.

On low-speed roadways ( $\leq 45$  mph), six-inch curbs can be located with the back of the curb at the face of the semi-rigid guardrail (See [EXHIBIT 9.25](#)).

On low-speed roadways ( $\leq 45$  mph), six-inch curbs should not be either in front of or for a distance in advance (upstream) of the guardrail end treatment (See [EXHIBIT 9.26](#)). The minimum curb-free distance should be 25 feet in advance of the first post of the guardrail end treatment.

For further information, see the [Roadside Design Guide](#) (Ref. 9.1) and the *Standard Plans* (Ref. 9.3), Standard Plan 743.



**Exhibit 9.25 Guardrail Installed Behind a Six-Inch Curb on a Low-Speed ( $\leq 45$  mph) Roadway**

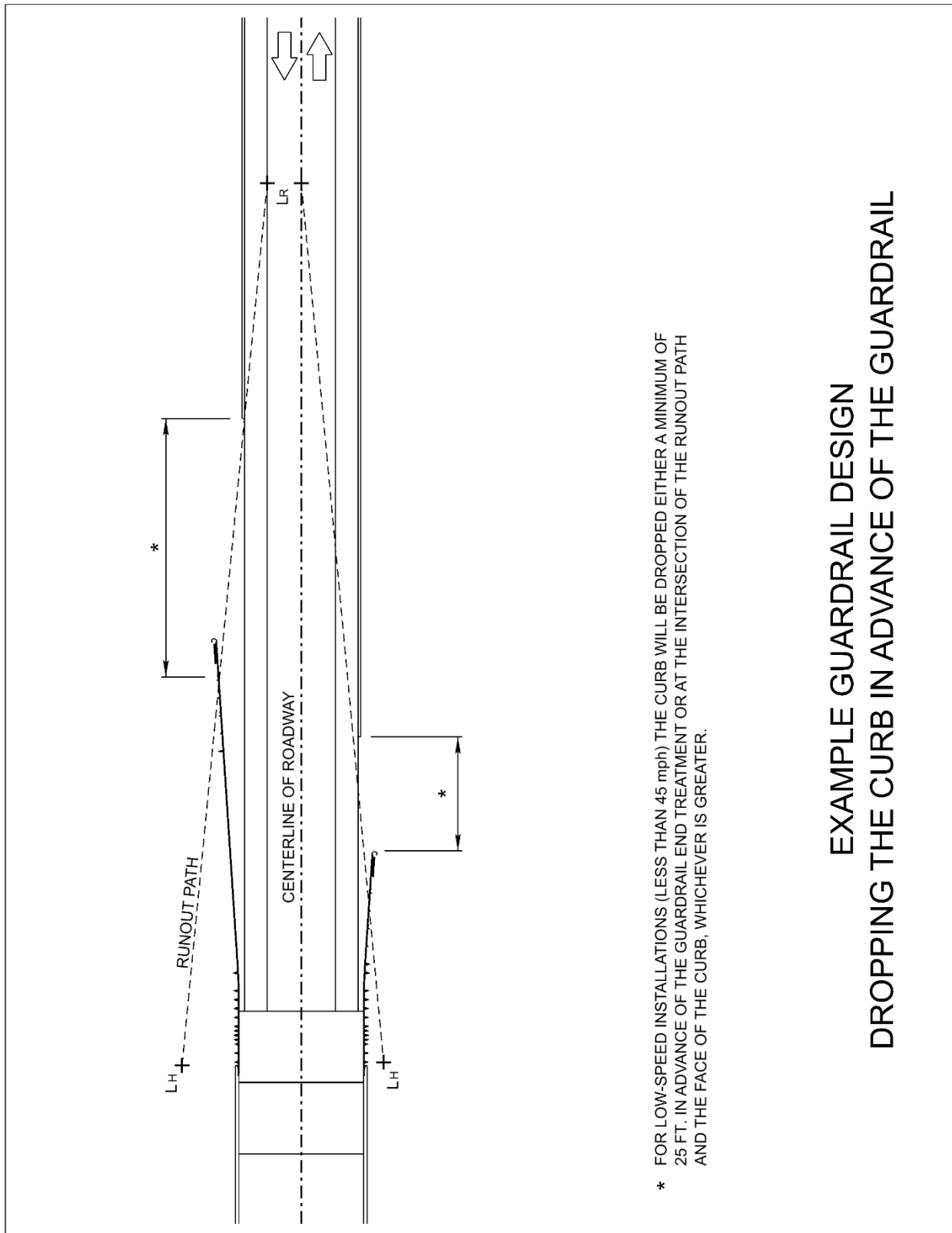


Exhibit 9.26 Dropping the Curb in Advance of the Guardrail

## 8. CRASH CUSHIONS AND IMPACT ATTENUATORS

Crash cushions are designed to decelerate a vehicle to a stop in head-on impacts and to redirect a vehicle away from rigid objects in side impacts. Crash cushions may be used alone or in conjunction with longitudinal barriers. Crash cushions may also be used in construction and work zones. See the Roadside Design Guide (Ref. 9.1) for further information on crash cushions and impact attenuators.

EXHIBITS 9.27 & 9.28 and the “Design Guides” section of the *Standard Plans* (Ref. 9.3) contain plans and examples of the crash cushions and impact attenuators used by **NDOT**.

### 8.A Inertial Barriers

Inertial barriers are sand-filled barrel modules arranged with increasing amounts of sand in the barrels as they are placed closer to the obstacle. Standard module mass varies from 200 to 2100 lbs. Inertial barriers operate by dissipating the energy of an impacting vehicle, transferring the vehicle’s momentum to the variable weights of sand in the barrels. Inertial barriers may be used to shield a variety of fixed object obstacles and are used primarily for protection of pole and column bases, lighting supports, and other rigid objects on the ground.

Inertial barriers should be set as far from the travel lanes as possible to avoid nuisance hits. The width of the last row of modules should be greater than the shielded object. The individual manufacturers supply design details for barrel layout. See the Roadside Design Guide (Ref. 9.1) for additional information.

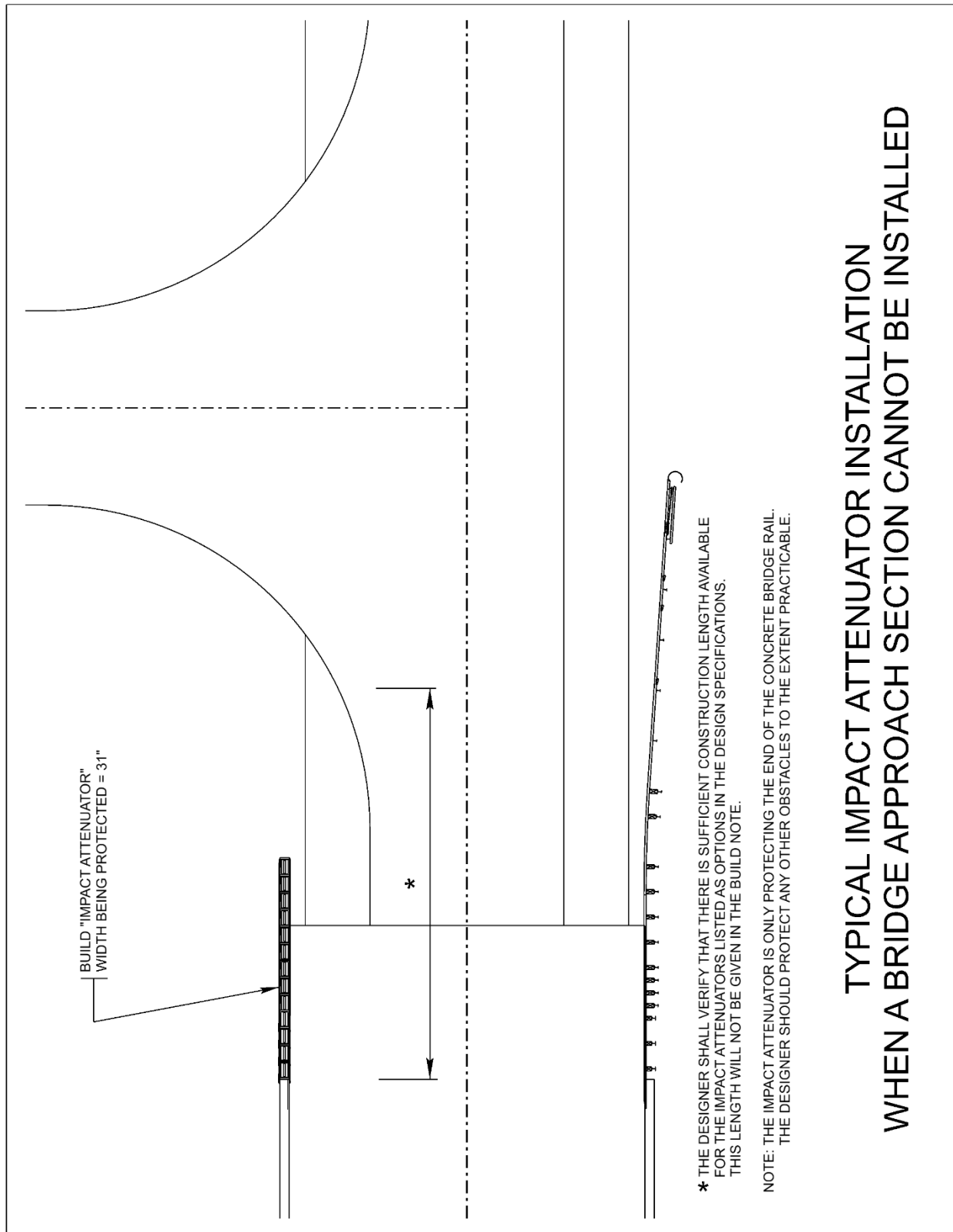


Exhibit 9.27 Impact Attenuator Installation at a Bridge Adjacent to an Intersection or Driveway (Protection of Bridge Railing Only)

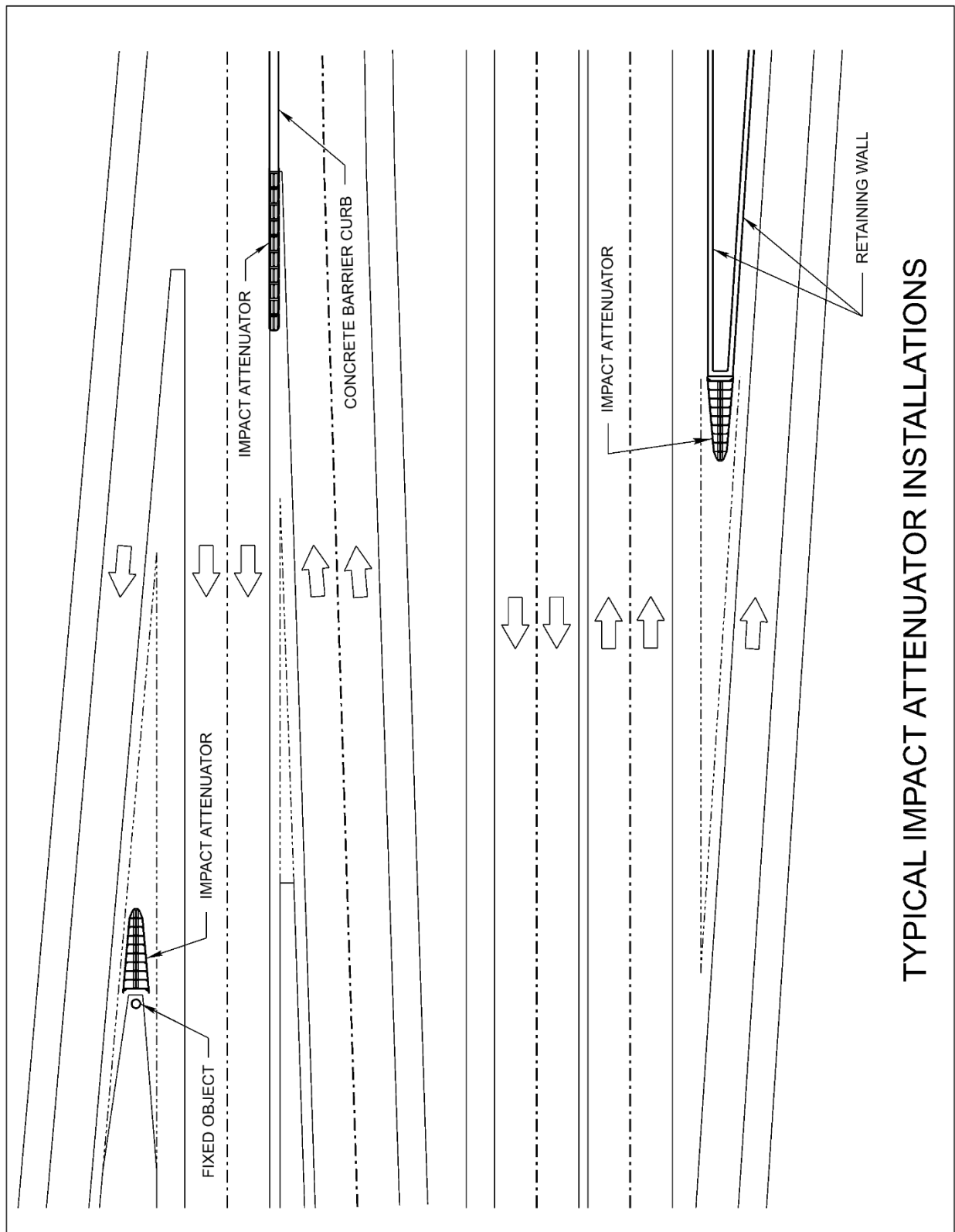


Exhibit 9.28 Typical Impact Attenuator Installations

## 9. DETERMINE THE PAY ITEM QUANTITIES

Guardrail pay items include, but are not limited to, the following:

- Mid-span Rail Support: Paid for by each. The Bridge Approach Section standard plan shows when the first post at the bridge rail sometimes hits a footing and cannot be placed; the fix is to change Post No. 2 to a larger post and place a 4x4 steel tube connecting to the bridge rail and Post No. 2 to support the back of the rail where Post No. 1 would be.
- Remove Guardrail: Paid for by the linear foot. Used for the removal of both cable and semi-rigid guardrail. The removal length includes the approach and terminal sections for each continuous length of guardrail.
- Remove Existing Surfacing: Paid for by the square yard.
- Semi-Rigid Guardrail (MGS, W-Beam, and Thrie-Beam): Paid for by the linear foot. Measure the semi-rigid guardrail from the bridge approach section to the end treatment(s). The semi-rigid guardrail pay length will include the guardrail radius section, if applicable. This pay item includes the guardrail posts, offset blocks, and hardware required for installation. The pay item for MGS and W-Beam is W-Beam Guardrail; the pay item for Thrie-Beam is Thrie-Beam Guardrail.
- Cable Guardrail: Paid for by the linear foot. Measure the cable guardrail from terminal anchorage section to terminal anchorage section. This pay item includes the guardrail posts and hardware required for installation.
- Bridge Approach Section Test Level 3 and Bridge Approach Section Test Level 2: Paid for by each (Length = 25 feet for Test Level 3 and 9 feet - 4.5 inches for Test Level 2).
- W-Beam to Thrie-Beam Transition Section: Paid for by each. Used to connect MGS or W-Beam guardrail to Thrie-Beam guardrail. This is a separate pay item when it is used separately from a BAS.
- Guardrail End Treatments: Paid for by each. Divided into the pay items Guardrail End Treatment Type I, Guardrail End Treatment Type II, and Guardrail End Treatment Type TL2.
- End Anchorage Assembly: Paid for by each. The end of the W-beam guardrail used at the off end of one-way bridges, includes two posts and the cable tie-down.
- Cable Guardrail Anchorage: Paid for by each.
- Culvert Mounted Guardrail Posts: Paid for by each. When the designer specifies culvert mounted guardrail posts, the posts are a separate pay item from the semi-rigid guardrail.
- Crash Cushions and Impact Attenuators: Paid for by each.
- Concrete Median Barriers: Paid for by the linear foot.
- Bullnose: Paid for by each. The pay item refers to the entire system from Post No. 10 on the left to Post No. 10 on the right and includes all Thrie-Beam guardrail, posts, cables, blockouts, and hardware necessary to complete the Bullnose installation.
- Surfacing Under Guardrail: Paid for by the square yard.

The designer will coordinate with **Bridge** to verify that all pay items are accounted for (e.g. Preparation of Structure).

For further information, see the *Standard Plans* (Ref. 9.3), the *Spec Book* (Ref. 9.4), and Chapter Twelve: Cost Estimating & Funding of this manual.



## 10. REFERENCES

- 9.1 American Association of State Highway and Transportation Officials, Roadside Design Guide, Washington, D.C., 2011.
- 9.2 Board of Public Roads Classifications and Standards, Nebraska Minimum Design Standards (MDS), Current Edition. (<https://dot.nebraska.gov/media/1z1n5kmb/nac-428-rules-regs-nbcs.pdf>)
- 9.3 Nebraska Department of Transportation, Standard/Special Plans Book (Standard Plans), Current Edition. (<https://dot.nebraska.gov/business-center/design-consultant/stand-spec-manual/>)
- 9.4 Nebraska Department of Transportation, Standard Specifications for Highway Construction (Spec Book), 2017. (<https://dot.nebraska.gov/media/g4qp4y0d/2017-specbook.pdf>)



The information contained in Chapter Ten: Miscellaneous Design Issues dated May 2022, has been updated to reflect the October 2023 Errata. The errata incorporates DES 22-05: "Rural Median Maintenance Turnarounds" (approved by the Nebraska Division of the FHWA on January 19, 2023), addresses errors, changes in procedure, changes in NDOT department titles, changes in other Roadway Design Manual chapters and other reference material citations occurring since the latest publication of this chapter.

Chapter Ten presents guidance for the design of New, Reconstructed and 3R projects: additional design guidance for 3R projects is provided in Chapter Seventeen.

## Chapter Ten

# Miscellaneous Design Issues

### 1. RAILROADS

(Map at <https://dot.nebraska.gov/media/frdpky5f/railroad.pdf>)

Many roadways in Nebraska are in close proximity to railroads. The designer for any roadway project that is near a railroad (within 300 feet from the centerline of the nearest track) should contact the **Highway Liaison Manager** in the **Rail Unit** in the **Local Assistance Division** as early as possible.

The applicable railroad company will review design issues such as earthwork and drainage near the railroad. Railroad insurance, purchased by the contractor, will be required for work within 50 feet of the centerline of the outside tracks. The roadway designer needs to estimate the percentage of work done in each group of work within the 50 foot limit for insurance purposes. The roadway designer will provide cost estimates for all of these items. See Chapter Twelve: Cost Estimating & Funding, Section 1.E, of this manual for further information.

The **Rail Unit** in the **Local Assistance Division** and the railroad company will need to be involved in discussions in the early planning stages for a project involving a viaduct or overpass. Roadway designers may also initiate safety improvements with improved crossing design and may expand the project by the possible consolidation of nearby crossings.

Any changes in design, such as adding a safety section, may change the level of involvement with the railroad. The **Rail Unit** in the **Local Assistance Division** should be informed of changes of this nature immediately.

### 1.A Railroad/Highway Grade Crossings

Railroad-highway crossing design must consider approach grades, sight distance, drainage, highway traffic volume and the frequency of train movements. The traffic volumes and frequency of train movements should be used as the basis for evaluating the exposure factor. If the current number of vehicles using the crossing multiplied by the number of trains per day is 50,000 or greater, grade separation should be considered. Existing railroad and site conditions will dictate whether an underpass or overpass should be used. For additional information, see Title 415, Nebraska Administrative Code, Chapter 5: "Rules and Regulations Concerning Administration of State and Federal Highway-Rail Grade Crossing Safety Projects ([https://sos.nebraska.gov/rules-and-regs/regsearch/Rules/Transportation\\_Dept\\_of/Title-415/Chapter-5.pdf](https://sos.nebraska.gov/rules-and-regs/regsearch/Rules/Transportation_Dept_of/Title-415/Chapter-5.pdf)), Chapter Five: Interstates, Grade Separations, and Interchanges, Section 2.E, of this manual and A Policy on Geometric Design of Highways and Streets (*Green Book*) (Ref. 10.2), Chapter 9, Section 9.12.

The ideal crossing geometry at railroad/highway grade crossings is a right-angle intersection of track and highway, with slightly ascending grades on both highway approaches to reduce the flow of surface water toward the crossing. For general coordination of mainline alignment at railroad grade crossings, the following design considerations apply:

1. Horizontal Alignment. The highway should intersect the railroad at a right angle without intersections or driveways nearby. This configuration maximizes the driver's view of the tracks and minimizes conflicting vehicular movements from crossroads and driveways. Crossings should not be located on either highway or railroad curvature where practical. Highway curvature limits the driver's sight distance and may cause the driver to concentrate on negotiating the curve rather than looking for a train. Railroad curvature may inhibit a driver's view down the tracks. Superelevation also complicates a crossing on a curve and may result in maintenance and rideability problems.

If the intersection between track and highway cannot be made at right angles, the variation from 90° should be minimized. At skewed crossings, motorists must look over their shoulders to view the tracks. Because of this awkward movement, some motorists may only glance quickly and not take the necessary precaution. Elimination, consolidation, relocation, realignment and signalization of crossings are all options that should be considered. Early coordination with the **Highway Liaison Manager** in the **Rail Unit** in the **Local Assistance Division** is required.

2. Vertical Alignment. Preferably, vertical alignment should be as flat as possible at railroad intersections to enhance sight distance, rideability, and braking and acceleration distances. Vertical curves should be of sufficient length to ensure an adequate view of the crossing. The roadway grade shall match the railroad grade. If the roadway crosses the railroad at a superelevated track section, the roadway profile shall be designed to incorporate the railroad superelevation.

The *Green Book* (Ref. 10.2), Chapter 9, Figure 9-66, recommends that the crossing surface be in the same plane as the top of rails for a distance of two-feet outside of the rails and that the surface of the highway shall not be more than three-inches higher nor six-inches lower than the top of the nearest rail at a point 30 feet from the rail, unless track superelevation dictates otherwise.

In cases where a railroad company has a maintenance road parallel to the tracks, it may be necessary to provide access for railroad maintenance across the highway. Cases such as this, and those involving horizontal clearances, may require special consideration. The designer should contact and coordinate with the **Highway Liaison Manager** in the **Rail Unit** in the **Local Assistance Division**.

When railroads and highways parallel each other in close proximity there is a possibility that long vehicles will not clear the railroad tracks when stopped at an access road to a state highway. The designer should provide sufficient distance along the parallel state highway for truck storage in these cases. When the highway is on new alignment, it is desirable to have 85 feet to 110 feet of storage between the railroad stop bar and the edge of the highway shoulders. This translates to about 110 feet to 145 feet from centerline of the closest railroad track to the edge of the closest through highway lane.

Where parallel railroad tracks run within 200 feet of the edge of the pavement and are intersected by surfaced roadways (highway, county or other), it is preferable to pave to the tracks instead of stopping at the end of the return. Work of this nature can only be accomplished by a special provision, as prepared by the **Rail Unit** in the **Local Assistance Division**. For additional information see Chapter Four: Intersections, Driveways, and Channelization, Section 3.A and EXHIBIT 4.24 of this manual.

Geometric design of the railroad-highway grade crossing should be done in concert with the determination of the appropriate traffic control devices (e.g., signs, pavement markings, flashing light signals and automatic gates). The **Traffic Engineering Division** should be consulted to coordinate design.

### 1.A.1 Railroad/Highway Crossing Surfacing

Each rail line has specific crossing requirements. Some railroads prefer crossings with high tonnage main line tracks to have at least 10 feet of asphalt surfacing between the edge of a crossing and a concrete roadway surface (See EXHIBIT 10.1). This allows replacement or installation of concrete cross ties with on-track equipment without removing concrete roadway surfacing. At other locations the concrete pavement should end at least six inches from the edge of timber or concrete crossings (See EXHIBIT 10.2). This six-inch gap is filled with asphalt to keep the expansion of concrete from moving track out of line and allows the railroad to replace crossing and timber cross ties.

Railroad crossings may be of various types, (such as timber, concrete or rubber), and widths. The railroad company will construct the railroad crossing. The designer should contact the **Highway Liaison Manager** in the **Rail Unit** in the **Local Assistance Division** to determine the type and width of railroad crossing to be used. For further information, see Chapter Twelve: Cost Estimating and Funding, Section 1.E, of this manual.

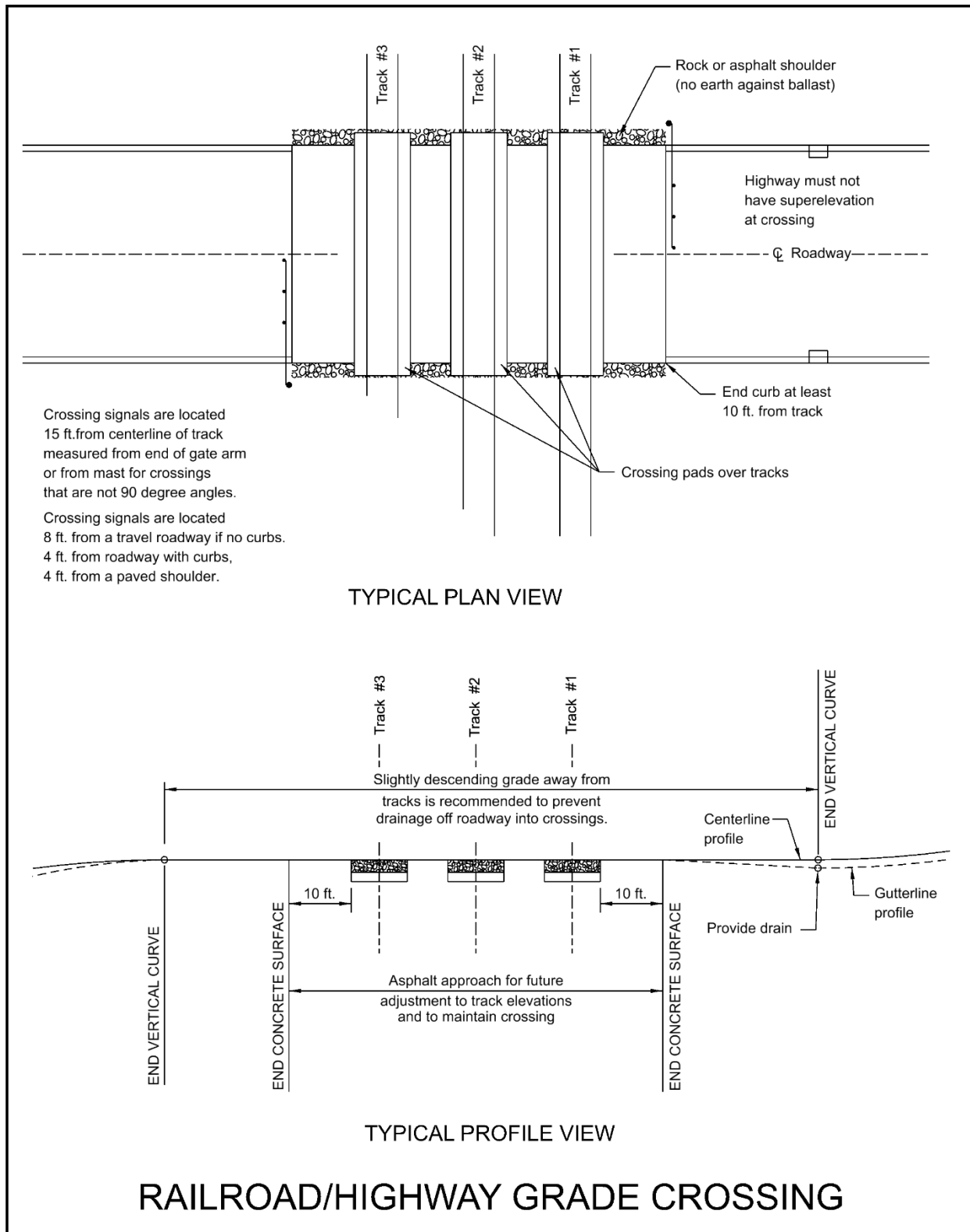


Exhibit 10.1 Railroad/Highway Grade Crossing

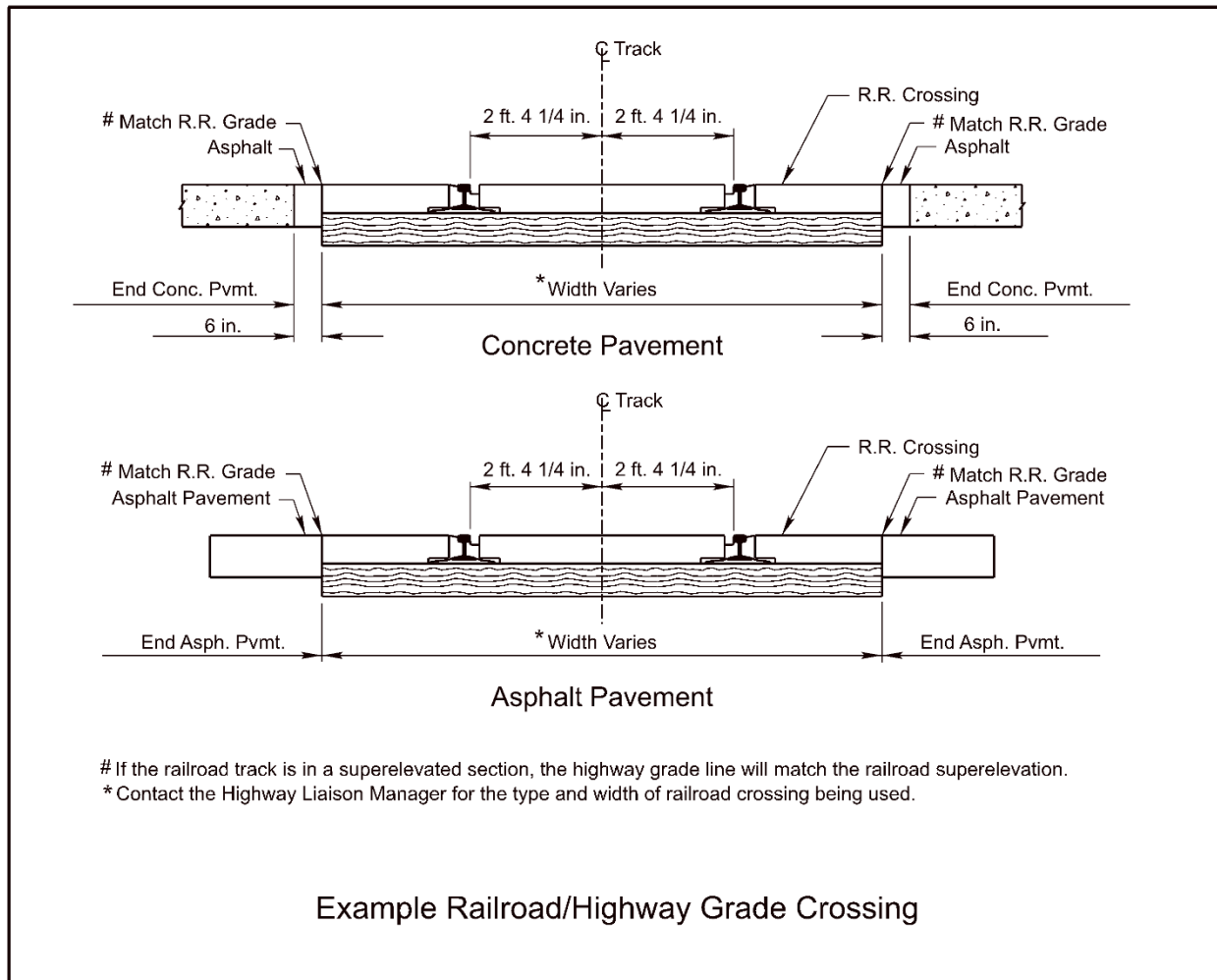


Exhibit 10.2 Railroad/Highway Grade Crossing

## 2. BRIDGE STRUCTURES

The **Federal Highway Administration** defines a bridge as “A structure, including supports, erected over a depression or an obstruction, such as water, a highway, or a railway, having a track or passageway for carrying traffic or other moving loads, and having an opening measured along the center of the roadway of more than 20 feet between undercopings of abutments or spring lines of arches, or extreme ends of the openings for multiple boxes; it may include multiple pipes where the clear distance between openings is less than half of the smaller contiguous opening.” If a multiple span concrete box culvert, as measured from the inside surface of the outer wall to the inside surface of the outer wall, is less than 20 feet along the centerline of the roadway it is a culvert and shall be designed by the roadway designer, (See the Drainage Design and Erosion Control Manual, Ref. 10.3). If a multiple span concrete box culvert measures more than 20 feet along the roadway centerline it is a bridge and its’ design shall be referred to the **Bridge Division Hydraulics Unit**. The designer shall pay particular attention to the effect of a skew on a box culvert as the skew may increase the length of a multiple span concrete box culvert, as measured along the roadway centerline, to bridge length.

The **Bridge Division (Bridge)** may determine that an existing bridge structure will be replaced with a concrete box culvert (See Chapter Seven: Earthwork, Section 3.A, of this manual for the demarcation between the culvert and grading contractor’s responsibilities).

The design of horizontal and vertical roadway alignments must be carefully coordinated with any bridges or other structures located within the project limits. Proper coordination may eliminate undesirable bridge characteristics.

### 2.A Horizontal Curvature

If practicable, horizontal curves and superelevation transitions should be avoided on bridges. However, safety is the primary consideration and introducing sharp horizontal curvature on approaches to avoid placing a curve on a bridge is not considered practical. Where a curve is required on a bridge, developing the superelevation on the approaching roadways and carrying the fully superelevated section continuously across the structure can simplify both bridge design and bridge construction. Due to the prevailing snow and ice conditions, the maximum superelevation rate permitted by **NDOT** on bridge structures is 6%.

In some cases, superelevation transitions are unavoidable on bridges and, while less desirable, can still be properly designed and constructed. The designer should coordinate the superelevation design with **Bridge** in the early stages of design (before bridge design is completed).

Superelevated roadways on bridges should not have a break in cross slope where the travel lane meets the shoulder. In other words, shoulder rollover is not permitted on bridge decks. If a break is provided between shoulder and roadway on the superelevated approach to the bridge, the section should transition to a continuous plane prior to the bridge structure.

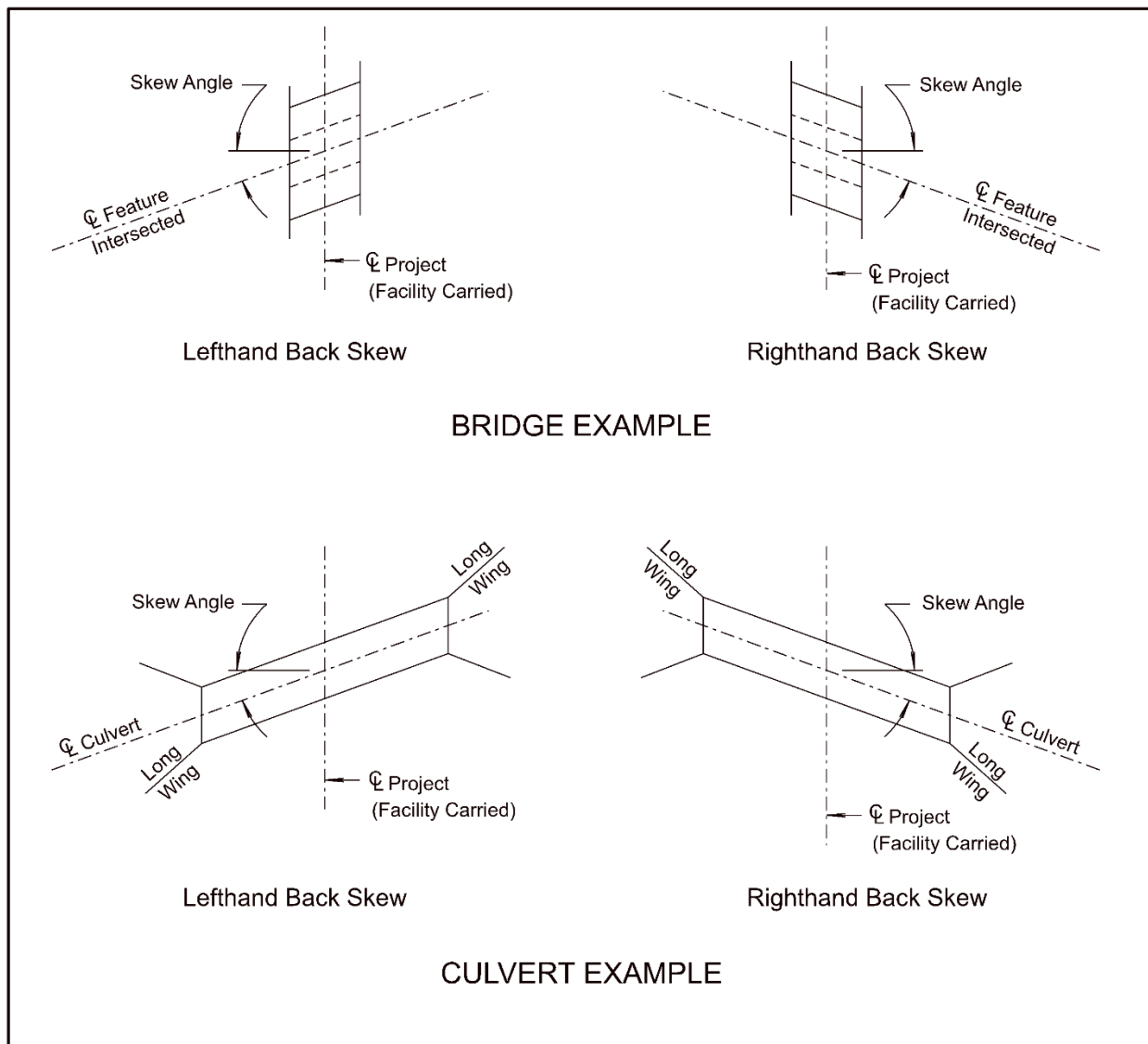
See Chapter Three: Roadway Alignment, Section 2, of this manual for further information



**2.B Skewed Structures**

EXHIBIT 10.3 illustrates the method for defining the crossing angle, or skew, between the mainline facility and the feature intersected (e.g., topographic anomalies, railways, waterways, etc.). When a bridge structure intersects a feature at a skew, the bridge abutments and piers are usually constructed parallel to the feature intersected to provide adequate horizontal clearances and reduce span lengths. Piers for structures over waterways are set parallel to the direction of the flood flow. Skewed intersections increase structure length, complexity and costs.

For bridge structures over roadways, railways and waterways, the maximum practical skew is 45°. Larger skews can be accommodated for facilities intersecting roadways and railways but require additional design and construction work. For culverts, the maximum desirable skew is 35°.



**Exhibit 10.3 Skew Angle Definition**

**2.C Bridge Grades**

Avoid vertical profile grades on bridges in excess of 5% to 6% as this can complicate the bearing design for certain types of bearing devices. Also, unanticipated movement can occur on bridges that are built to a steep grade. The grade line on bridge decks should preferably be tangent. For long bridges where drainage is confined to the bridge deck, a 0.5% grade is the desirable minimum.

**2.D Vertical Curvature**

Avoid placing bridges on crest and sag vertical curves with K values in excess of 143 U.S. Customary as they may have an inadequate longitudinal slope to drain the bridge deck. Longitudinal drainage is not a significant concern for bridges with open, free-draining rail systems. See Chapter Three: Roadway Alignment, Section 3, of this manual for further information.

Where practicable, the low point of a sag vertical curve for a roadway under a bridge should be located at least 100 feet from the limits of the bridge structure. This will help to reduce the need for drainage structures under the bridge and will reduce the ponding of water that may weaken the earth foundation beneath the bridge. Ice accumulation on the roadway would also be minimized since the low point of the sag vertical curve would not be located within the shadow of the bridge structure.

**2.E Vertical Clearances**

**2.E.1 Grade Separations**

Minimum vertical clearances for various conditions are shown in EXHIBIT 10.4. The minimum vertical clearance shall be measured from the high point of the roadway, including shoulders, which may or may not be at the profile grade point. For new structures, it is desirable to include a 0.50 foot allowance in addition to the minimum clearance for future resurfacing. The values provided are intended for general guidance only. Final grade decisions should be coordinated with **Bridge**.

Vertical alignment will need to be coordinated with structural requirements for superstructure depth to allow for proper clearance between grade separations. **Bridge** will provide a preliminary estimate of superstructure depth for the types of structures to be used so that preliminary grades can be designed.

Type	Minimum Clearance
Structures over roadways	See the <u>Minimum Design Standards</u> (Ref. 10.5)
Roadway or pedestrian bridge over railroad	23.50 feet (1)
Roadway under pedestrian bridge	See the <u>Minimum Design Standards</u> (Ref. 10.5)

1. Measured above the plane of the top-of-rails. If the required vertical clearance cannot be met, a minimum vertical clearance of 23.00 feet may be used with the approval of the **Assistant Bridge Engineer** in **Bridge**.

Note: Minimum vertical clearances also apply to roadway shoulders.

**Exhibit 10.4 Minimum Vertical Clearances for Structures**

## 2.E.2 Stream Crossings

Bridges over meandering rivers, streams and other natural waterways preferably should not be located on a bend in the channel. This can result in less than desirable stream flow characteristics and may require excessive rock embankment to protect the structure from erosion and scour. Divided roadway facilities intersecting with a bend in a natural waterway may require construction of parallel bridges with different span configurations in lieu of the more desirable twin bridge configuration.

The vertical profile design in the vicinity of a stream crossing and the allowable overtopping frequency for the roadway dictate the required waterway opening for a bridge structure. The **Bridge Hydraulics Section** determines required waterway openings. Prior to preliminary design, the roadway designer will provide the **Bridge Hydraulics Section** with a very preliminary, “best guess” profile at bridge locations for use in hydraulic analysis. For some conditions required waterway openings may consist of the combined bridge opening and roadway overtopping. [EXHIBITS 10.5 AND 10.6](#) illustrate the basic criteria used to establish bridge length and vertical profile for crest and sag or level profiles, respectively.

## 2.F Intersections

Avoid placing bridges close to intersections if practicable, particularly where guardrail is required.

## 2.G High Embankments

Embankment for grade separation structures should be of sufficient height to ensure that adequate vertical clearance is provided over the facility intersected. Excessive embankment height will increase span length thus increasing costs.

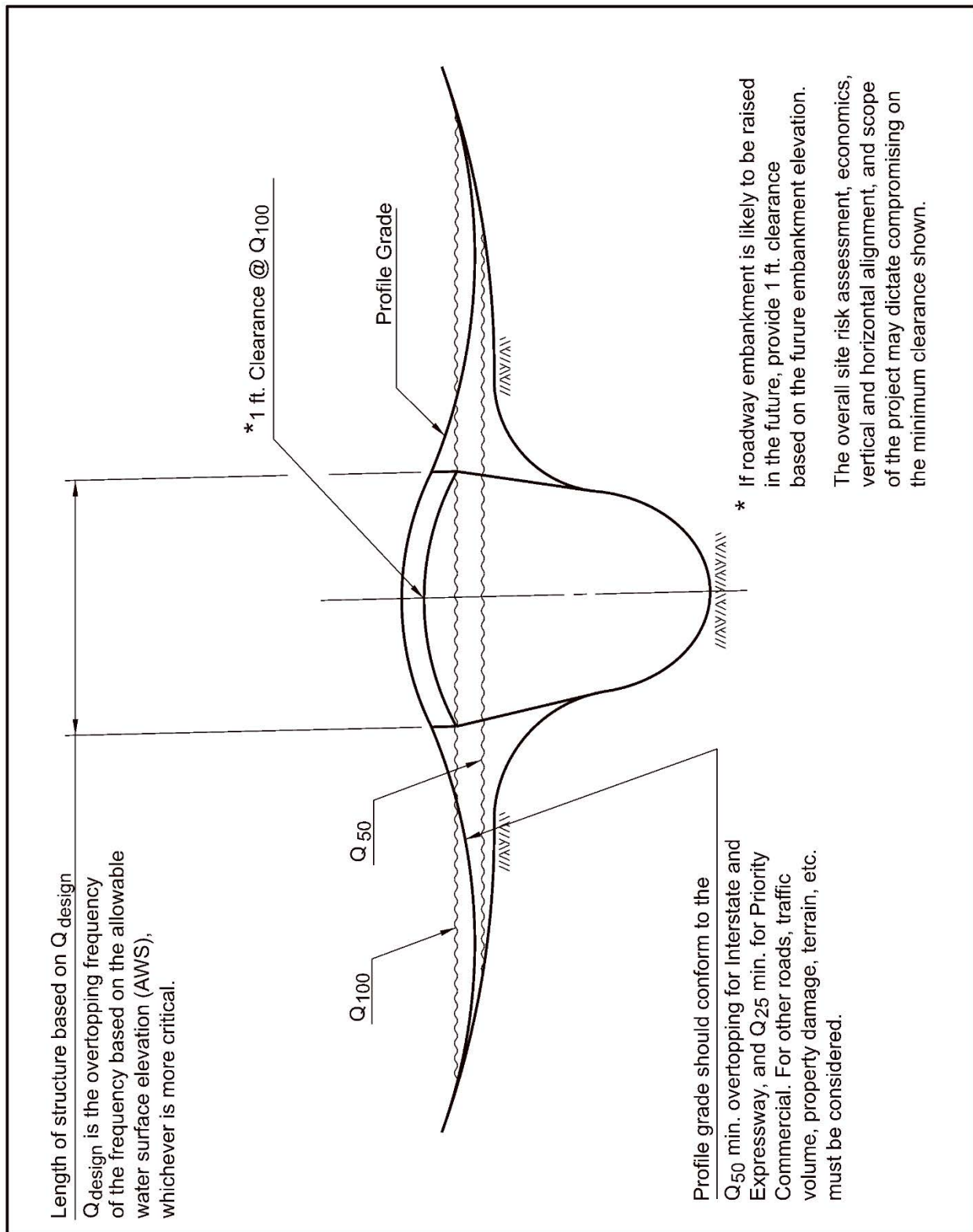


Exhibit 10.5 Vertical Stream Clearances for Crest Profile

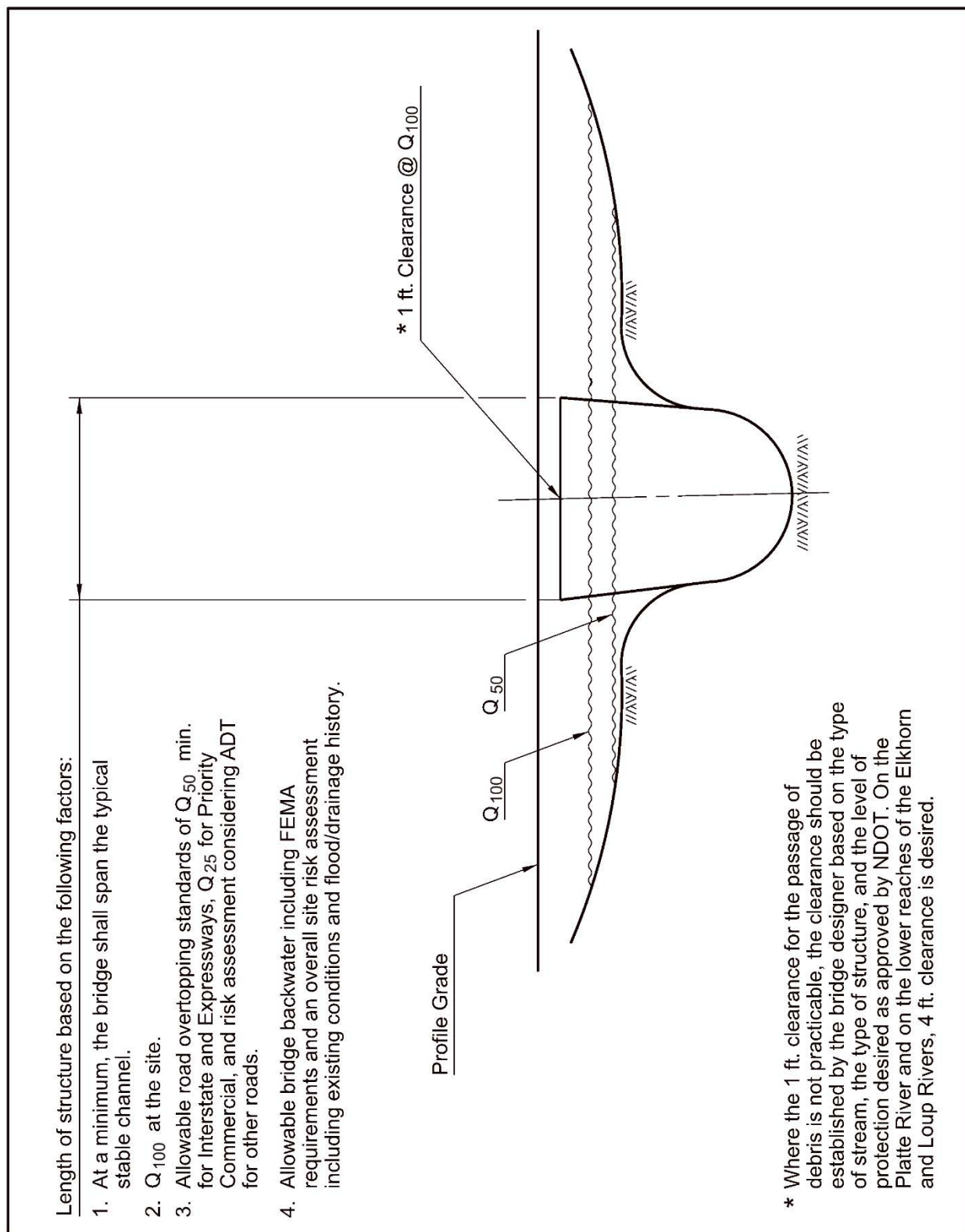


Exhibit 10.6 Vertical Stream Clearances for Sag or Level Profile

### 3. AIRWAY HIGHWAY CLEARANCES

#### 3.A Nebraska Division Of Aeronautics

An "Application for Permit to Build" must be requested from the **NDOT Division of Aeronautics (NDA)** for:

1. All new structures throughout the **State of Nebraska (State)** which exceed 150 feet in height above ground level at the point of installation.
2. Increasing the height of existing structures which results in a final height exceeding 150 feet above ground level at the point of installation.

Instructions and the permit form may be found at <https://dot.nebraska.gov/media/j2journmb/permittobuild-individual.pdf>. This form *must* be submitted to the **NDA** at least 60 days prior to the date that the construction or alteration is to begin.

#### 3.B Federal Aviation Administration

The **Federal Aviation Administration's (FAA)** regulations for airway highway clearances (<https://www.faa.gov/airports/central/engineering/part77>) have been published as "Part 77, Federal Aviation Regulations". The **FAA** requires written notification prior to construction in the vicinity of an airport in order to:

- Evaluate the effect of the proposed construction or alteration on the operation of the airport
- Determine the effect of the proposed construction or alteration on air navigation
- Identify mitigating measures
- Map the alteration

The **FAA** provides a "Notice Criteria Tool" to assist the designer in determining whether coordination with the **FAA** is required. This tool may be found on the internet at: (<https://oeaaa.faa.gov/oeaaa/external/gisTools/gisAction.jsp?action=showNoNoticeRequiredToolForm>). All airports, both public and private, that are within a four-mile radius of a project should be identified prior to the plan-in-hand (EXHIBIT 10.7); an Airport Buffer KMZ may be found at [\\dotfs\Design\Google Earth KMZ](#). Public airports may be identified using the airport layer in the **NDOT** "Preliminary Environmental Report". There is no data base for private airports, they can be identified using Google Earth. As part of the plan-in-hand distribution, letters will be sent to any private airports within the study area stating where the project is located and the type of work to be done. Any comments received prior to the NEPA documentation will be included in the document.

If required, FAA Form 7460-1, "Notice of Proposed Construction or Alteration", *must* be filed with the **FAA** at least 45 days before work starts and **FAA** coordination may take up to six months. If the designer does not receive a response within two weeks he should contact the **FAA** to verify that they have received the information and that it is complete. FAA Form 7460-1 should be filled out during the Roadway Design Details Phase of the project (Clarity Task #5508). All modifications, both permanent and temporary, are subject to the notice requirement. The designer will transmit this form to the **NDA** for coordination with the **FAA**. This form may be found at (<https://www.faa.gov/forms/index.cfm/go/document.information/documentID/186273>).

The **NDA** should be consulted early in the design process for current regulations and notification requirements related to highway projects near civil and military airports and heliports and for information on future growth planned at the airport.

**Conditions requiring the filing of FAA Form 7460-1:**

- Any construction or alteration exceeding 200 feet above ground level
- Any construction or alteration:
  - Within the four-mile envelope of the airport, which is constructed by swinging a four-mile arc from the center of each end of each runway and connecting the adjacent arcs by tangent lines (See [EXHIBIT 10.7](#))
  - Within 10 miles of the end of the runway. This protected area is three miles wide, centered on the runway, extending for the entire 10 miles and includes a slope protection elevation which is delineated by 100:1 slope for three miles off the end of the runway, a level slope for four miles and a 100:1 slope for an additional three miles (See [EXHIBITS 10.8 & 10.9](#))
  - Within 20,000 feet of a public use or military airport which exceeds a 100:1 surface from any point on the runway of each airport with at least one runway more than 3200 feet in length
  - Within 10,000 feet of a public use or military airport which exceeds a 50:1 surface from any point on the runway of each airport with its longest runway no more than 3200 feet in length
  - Within 5000 feet of a public use heliport which exceeds a 25:1 surface
- Any highway, railroad, or other transverse way whose prescribed adjusted height would exceed that above noted standards
- When requested by the **FAA**
- Any construction or alteration located on a public use airport or heliport regardless of height or location

**Examples of Permanent Construction or Alterations:**

- Structures
- Elevated Signs
- Fences
- Light Fixtures
- Power and Cable Lines
- Roadways

**Examples of Temporary Construction or Alterations:**

- Construction Equipment (if construction equipment breaks the slope protection elevation, the contractor or **NDOT** can propose an amendment to the slope protection study.)
- Haul Routes
- Staging Areas
- Stock Piles
- Temporary Lights

**Additional Submittals to the NDA:**

- Plan of the proposed construction or alteration showing the relation to the nearest runway
- The perpendicular distance from the centerline of the nearest runway to the proposed construction or alteration
- The projected distance along the centerline of the runway to the proposed construction or alteration
- The ground elevation at the site of the proposed construction or alteration
- The height of the proposed construction or alteration
- Accurate geodetic coordinates conforming to NAD 83

**3.C NEPA Coordination**

The **Roadway Design Division** will provide copies of all official correspondence with the **FAA**, **NDA**, private airport authorities, and/or the local airport authority including any responses or comments to the **NEPA Specialist** in the **Environmental Project Management Unit (EPMU)** of the **Project Development Division (PDD)**. This correspondence will be included in the NEPA document. The contractor commitment below will also be included in the NEPA document for all public airports. Private airports do not need specific commitments unless comments are received from the airport manager.

Commitments for public airports:

*Because of the proximity to the ----- Airport in ----- , the height of any equipment used in the construction of the project (or any antennae installed on the equipment) shall not exceed the local airport's Height Restriction Zoning. Any Contractor involved in the project shall use the Notice Criteria Tool available at <https://oeaaa.faa.gov/oeaaa/external/portal.jsp>. If required, the Contractor shall file a 7460-1 Form with the Federal Aviation Administration (FAA). The form shall be required if the Contractor uses any equipment over 200' tall, or the equipment breaks a 100:1 slope from a public-use airport. This includes any trucks or equipment used during the construction of the project. NDOT's Roadway Design Division shall verify clearance for permanent construction in the controlled zone from the Nebraska Department of Aeronautics (NDA) and FAA. NDOT's Roadway Design Division shall identify those contracts that shall require the special provision concerning the Contractor's responsibility to gain FAA and NDA clearance for temporary encroachments due to construction operations. NDOT's Plans, Specification & Estimates (PS&E)/Contracts shall include the special provision in the appropriate project contracts. (Contractor)*



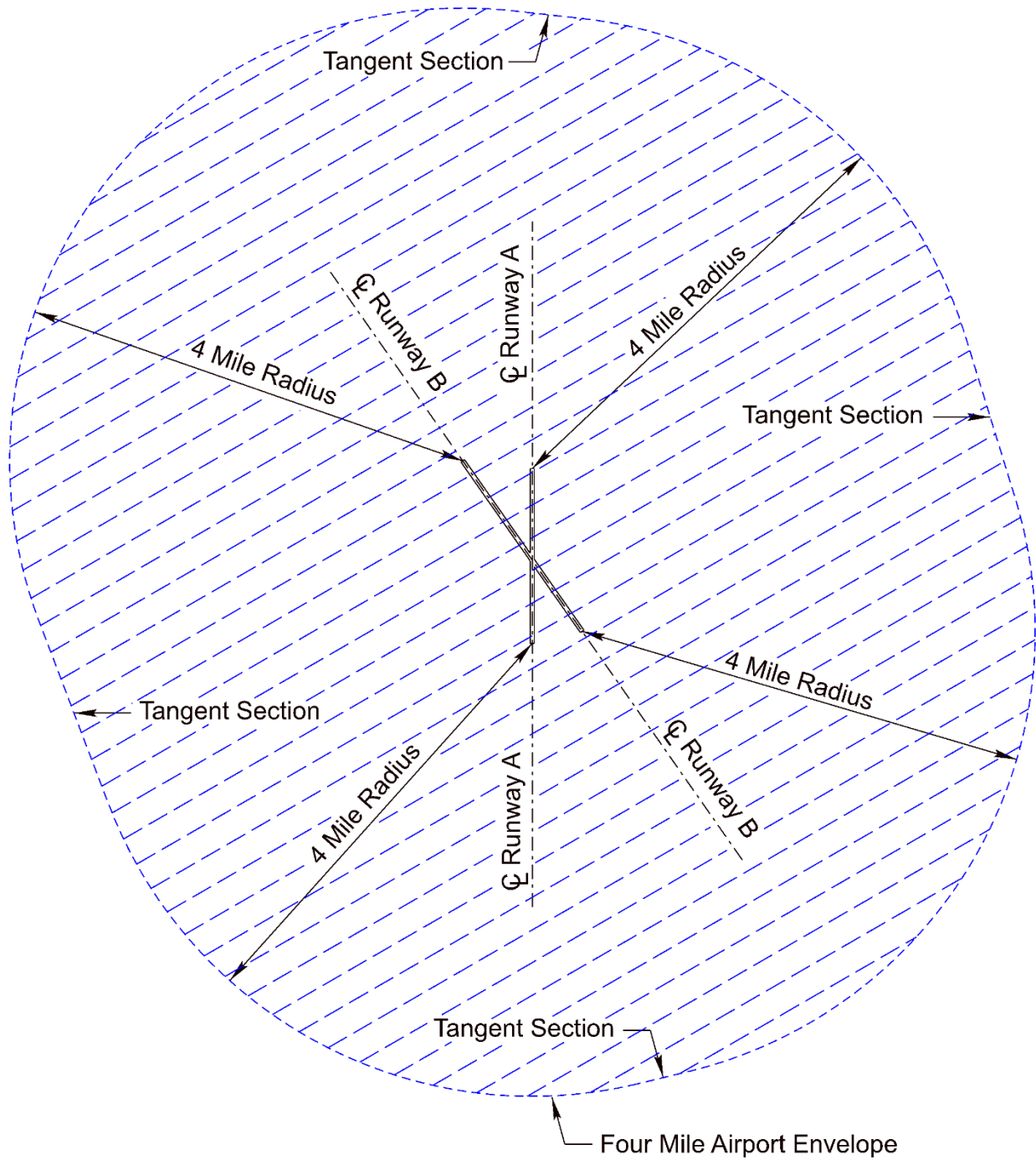


Exhibit 10.7 Four Mile Airport Envelope

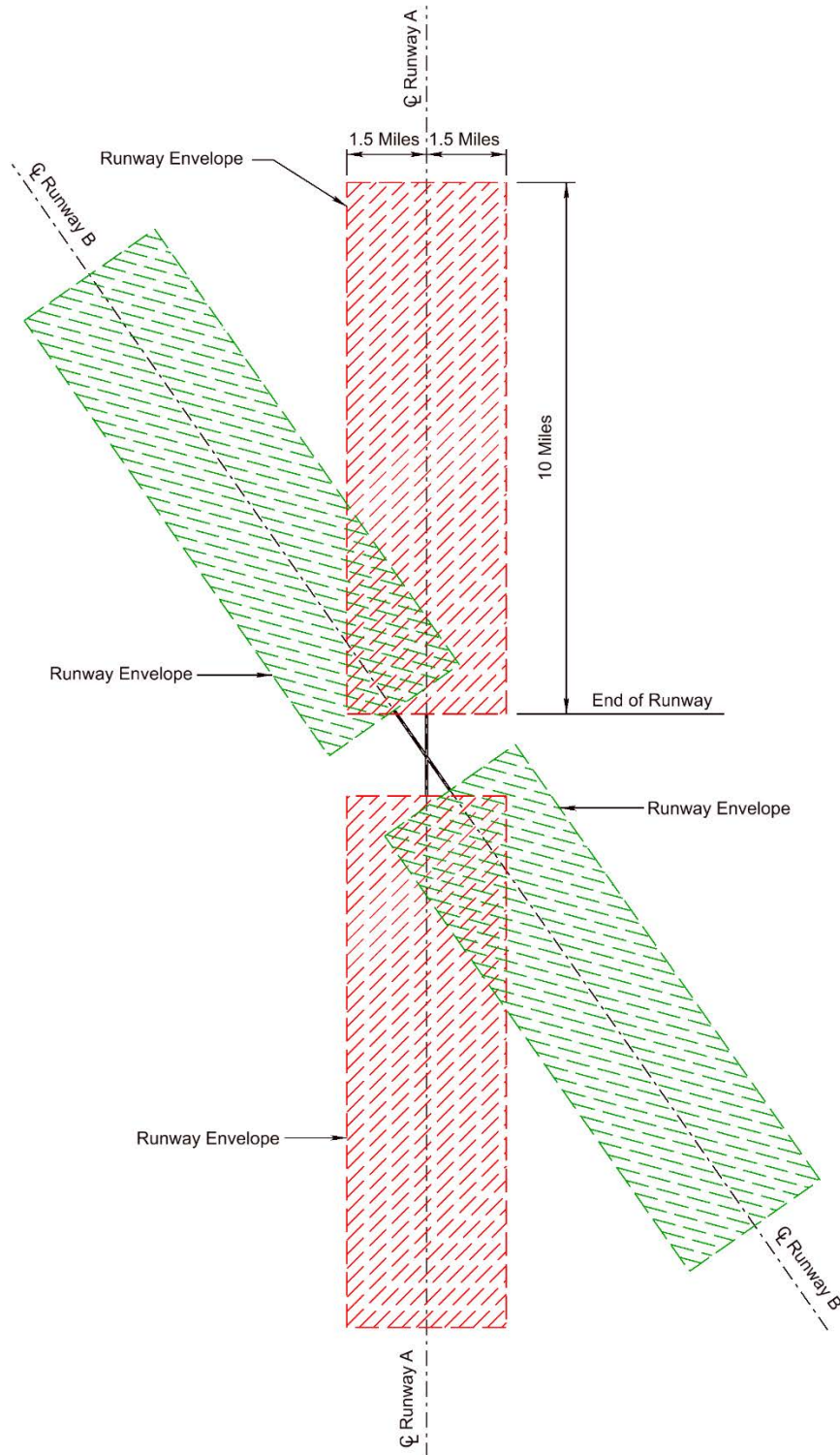


Exhibit 10.8 Runway Protected Area

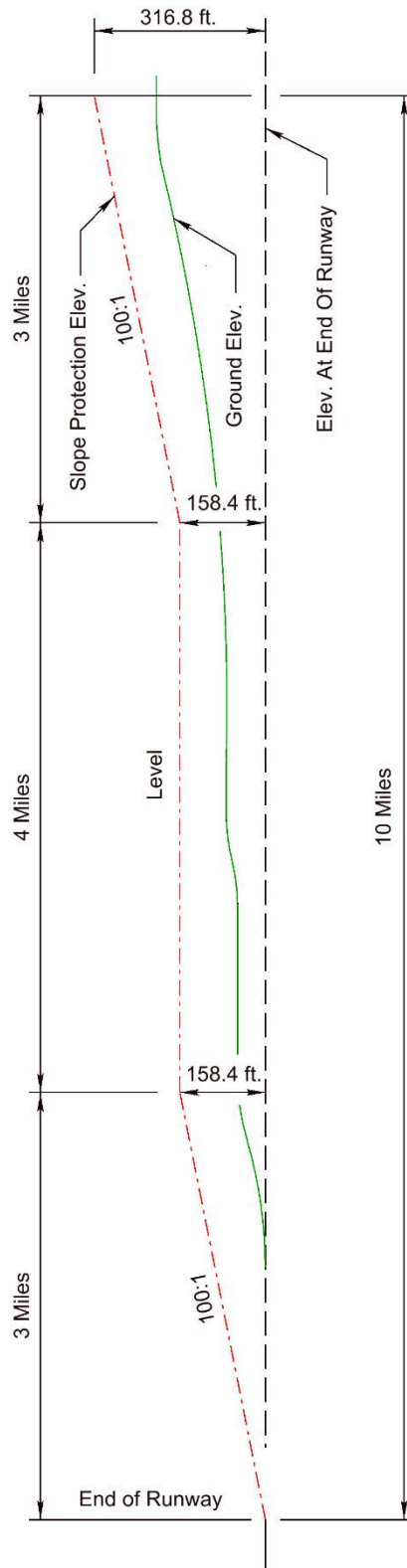


Exhibit 10.9 Runway Slope Protection

#### 4. LANDSCAPING

Landscaping is an ongoing and essential part of **NDOT's** Six-Year Plan and is the responsibility of the **Roadside Development & Compliance Unit (RDC)** in **PDD**. Landscaping includes, but is not limited to, plantings, scenic view development, use of retaining walls, median treatments, slope rounding, berms, aesthetic treatment for noise walls, and other treatments for environmental, functional or aesthetic purposes.

Landscaping provides many functional and aesthetic benefits that are as integral to good roadway design as are geometrics. Landscaping should enhance the visual quality of the roadway environment, thus reducing the impact of the roadway on the adjacent area. The goals of landscaping include:

- Enhance the safety of the roadway by maintaining recovery areas for errant vehicles.
- Accentuating the roadway features with appropriate plantings.
- Reduce maintenance costs by the use of living snow fences, erosion control, limited mowing, and the prompt removal of tree seedlings.
- Conserve, enhance and effectively display the natural environment and beauty of the roadway landscape, providing a pleasant driving experience for the traveler.
- Encourage wildlife conservation and habitat improvement, within the roadway right-of-way, through selected plantings and limited mowing.

Implementation of the landscaping policy includes the following activities:

1. During the development of major (normally not resurfacing, lighting, etc.) roadway projects, urban or rural, **PDD RDC** will review and recommend an appropriate landscaping treatment for each project.
2. **RDC** involvement will begin at the engineering review or corridor study stage of project development to promote early identification of the potential for landscaping. Landscaping recommendations will be included in the engineering review report, corridor study report and in the design public hearing engineering statement.
3. **RDC** will review design plans prior to the plan-in-hand and will furnish written landscaping and erosion control recommendations to the roadway designer for evaluation during the plan-in-hand.
4. **RDC** will review the plan-in-hand report to estimate specific erosion control needs and to make further landscaping recommendations, as necessary.
5. Landscaping recommendations will be included in the design public hearing engineering statement.
6. **RDC** will review the limits of construction plans and forward final landscaping recommendations and specifications and final erosion control recommendations to the roadway designer.
7. Erosion control specifications will be sent to the roadway designer after a joint review of final cross-sections with the designer is completed.

#### 4.A Tree Planting and Removal

Every effort will be made to minimize disruption to the surrounding environment. Where trees and other desirable flora can be saved, consistent with sound engineering judgment, they will be. Normally, trees and other flora located within the clear zone (See Chapter Six: The Typical Roadway Cross-Section, Section 9.A, of this manual) or within the limits of construction will be removed, however, the retention of healthy trees and other desirable flora will be reviewed on a case-by-case basis by **RDC** and the **District Engineer** to determine appropriate action. Guardrail, retaining walls, and other alternatives may be considered before healthy trees are removed. The cost of protecting trees should not be the only determining factor when considering their removal. Tree removal may be a factor in determining the need for tree planting.

When a significant amount of additional right-of-way is required for a project that would not otherwise be classified as "major," **RDC** should review the project for appropriate landscaping treatment, even if the latter would require the purchase of additional right-of-way outside of the proposed construction limits. Right-of-way will not be acquired solely for tree planting, unless needed to comply with Section 404 Permit requirements, (See Chapter Thirteen: Planning and Project Development, Section 5.B.4, of this manual).

A special provision is required for removing and resetting trees from the construction zone with the appropriate size tree spade. **RDC** will determine the feasibility of tree removal and tree spade size.

#### 4.B Roundabout Landscaping

Landscaping for a roundabout should be selected and strategically placed to help improve the overall operation of the roundabout when possible. Plantings in the central island can help provide recognition of the roundabout by approaching drivers and aid in reducing their approach speeds. While allowing adequate sight distance to the left, these plantings help drivers make better judgments concerning the distance to approaching vehicles in the roundabout by filtering out other distracting movements.

All guidelines for intersection sight lines and roadside safety must be followed. The central island plantings must be of sufficient volume to be visible in advance of the intersection and reduce headlight glare across the roundabout, but not infringe on necessary sight distances for motorists and pedestrians. This is accomplished by deliberate positioning of plant material to maximize the view between vegetative elements and minimize the view of opposing vehicles. Plantings also need to address snow drifting concerns and the shedding of deciduous vegetation on the circulatory roadway. Plant types should be selected to limit excessive maintenance when possible.

## 5. SNOW CONTROL

Snow drifting may be a problem when the prevailing winds are from the north or west. Snowdrifts on roadways can be minimized by several different methods, including:

- Cross-section modification
- Structural snow fencing, both temporary and permanent
- Living snow fencing

The **District's** input regarding the location of existing snow fences will help to identify locations susceptible to drifting snow. If aerial photos were taken in late fall or early winter they may show the location of existing snow fence. Designers are responsible for contacting the **District Engineer** to see if snow shots are desired for the plan-in-hand inspection. Snow shots are cut stations where the top of the backslope is less than 60 feet from the roadway centerline and the backslope elevation is greater than the centerline elevation.

Allowing a greater ditch area for the accumulation of snow at locations susceptible to drifting can minimize snowdrifts on roadways. Normally snowdrifts on a roadway occur at the ends of cut sections. Ditches may be widened to provide more area for snow accumulation. The backslope, especially at the ends of high cuts, should be laid back from its normal 1:3 slope (See Chapter Six: The Typical Roadway Cross-Section, Section 10.H, of this manual).

Structural snow fencing is often used to reduce snow drifting. Annually, maintenance units will place temporary snow fence along the right-of-way in areas of known snow drifting. Along roadways with limited right-of-way, temporary snow fencing may be placed on private property. Permanent snow fencing panels may be needed where a cut section becomes a fill section. Living snow fencing may also be used to reduce snow drifting. If the right-of-way is sufficient, shrubs and trees can be planted along right-of-way or fence lines. Contact **RDC** for the possibility of using living snow fence at the right-of-way line.

## 6. FENCING

Interstates and freeways shall be fenced and some expressways may be fenced. Chainlink fencing is used in urban, developing urban and suburban areas. When fencing is specified (as it is on Interstate and freeway projects), the fencing is run along the right-of-way line according to the Standard Specifications for Highway Construction (*Spec Book*), Section 910 (Ref. 10.12) (<https://dot.nebraska.gov/media/g4qp4y0d/2017-specbook.pdf>). The following exceptions and criteria should be kept in mind:

- Where there is a frontage road, the fence is placed between the frontage road and the mainline
- Fences should tie into the ends of box culverts or cattle passes
- Fences should tie into the ends of existing fences and grade separation structures. Where the crossroad runs underneath, fences may run underneath the structure
- If a portion of a utility line within the right-of-way is left undisturbed, the access fence may be run just inside of the utility line
- At rural interchanges, fencing should extend 500 feet along the cross road from the ramp termini

Chainlink fencing is also used for pedestrian barriers on bridges, (**Bridge** will provide details). The need for fencing expressway projects should be discussed at the plan-in-hand inspection. Refer to the Standard/Special Plan Book (Ref. 10.4), Standard Plan 710, for fencing details.

In rural areas, depending on the function and use of the adjoining property, barbed wire or woven wire fences will be erected. The responsibility for removing, resetting, or rebuilding fences and cattle guards rests with the property owner, who is compensated by **NDOT** as necessary.

Interstate fencing is a construction item and will be included in the cost estimate. Other fencing is generally a right-of-way item, the roadway designer should contact the **Right-of-Way Division** for assistance. For further information see Chapter Five: Interstates, Grade Separations, and Interchanges, Section 1.H.1, Chapter Twelve: Cost Estimating & Funding, EXHIBIT 12.2 and Section 7.B.2, and Chapter Fifteen: Right-of-Way, Section 7.C, of this manual.

For additional information, see Section 8 of this chapter for fencing adjacent to retaining walls and Chapter Sixteen: Pedestrian and Bicycle Facilities, Section 4.A, of this manual for fencing behind sidewalks adjacent to steep slopes.

## 7. CATTLE PASSES

New cattle passes should be built if either of the following criteria is met:

- The appraised segregation damages equal or exceed the cost of constructing the structure
- The property owner pays for the difference in the cost of the structure and any segregation damages

Existing cattle passes should be perpetuated if either of the following criteria is met:

- The property owner's title or any other legal document indicates that the owner has a non-revocable right to use the existing structure as a livestock crossing
- It is apparent that the structure was built to alleviate damage to a segregated property and is being used for a livestock crossing

The design of cattle passes shall give the contractor the option of furnishing a precast unit, provided that the fill height is within the structural limits of the unit. It is important that cattle passes be designed without bends or grade breaks. If cattle cannot see out the other end of the passage, they will not enter it.

## 8. RETAINING WALLS

The need for a retaining wall may be determined during any of the following activities:

- Engineering review
- Preliminary design
- Plan-in-hand
- Roadway design

When a retaining wall with a height of three-feet or greater is built in an urban area, a chain link fence with a nominal height of four-feet shall be erected adjacent to the retaining wall (just behind it) on public right-of-way.

Section 2.2.11 of the Bridge Office Policies and Procedures (BOPP) Manual (<https://dot.nebraska.gov/media/cpodk45c/bopp-manual.pdf>) outlines **NDOT's** basic procedure to be followed in the design of retaining walls.

## 9. OLD ROAD OBLITERATION

Once existing pavement on an abandoned alignment is no longer needed, (such as for phasing or property access), the pavement may be removed. The quantities of removed pavement shall be paid for by the sq. yd. The plans for old road obliteration should be put on General Information sheets (See Chapter Eleven: Highway Plans Assembly, Section 4.G, of this manual). The "Typical X-Section" portion of the Standard/Special Plans Book (Ref. 10.4), Plan 1110, illustrates cross-sections for old road obliteration.



## 10. MAILBOX TURNOUTS AND SUPPORTS

On one-way streets, mailboxes may be on the left side if designated by the local postmaster. Where a mailbox is located at a driveway, it shall normally be placed 17 feet beyond the driveway surfacing on the right hand side of the road in the direction of travel as designated by the local postmaster for each delivery route. A mailbox should not be located on urban roadways where through driving lanes are adjacent to the curb. **FIGURE 11.4** of the Roadside Design Guide (Ref. 10.11) shows minimum clearance distances for mailboxes near intersections with county roads.

Asphalt surfacing shall be used for mailbox turnouts, if available. New and Reconstructed projects shall have a minimum eight-foot-wide mailbox turnout (or a total of 20 feet of surfacing width from the centerline). See Chapter Seventeen: Resurfacing, Restoration and Rehabilitation (3R) Projects, Section 6.E, of this manual for 3R project design guidance. The Standard/Special Plans Book (Ref. 10.4), Standard Plan 307, (<https://dot.nebraska.gov/business-center/design-consultant/stand-spec-manual/>) illustrates mailbox turnouts for various roadway types, (these plans provide surfacing quantities for typical mailbox turnouts, but additional surfacing will be needed for turnouts that have more than one mailbox support post).

No more than two mailboxes may be mounted on a single support structure, (See the Standard/Special Plans Book, Ref. 10.4). **NDOT** provides mailbox supports to the contractor, so the roadway designer needs to have a mailbox support count. The plan build note shall include the number of supports, the mailbox location(s), and the required area of special mailbox surfacing.

For additional information see a Guide for Erecting Mailboxes on Highways (Ref. 10.7), the Roadside Design Guide (Ref. 10.11), and Title 412, Nebraska Administrative Code, Chapter 2 ([Microsoft Word - 412 NAC 2 - Accommodation of Mailboxes Language\\_POST-HEARING.docx \(nebraska.gov\)](#)).

## 11. RURAL MEDIAN MAINTENANCE TURNAROUNDS

To provide consistency, maintenance turnarounds for rural Interstates, freeways, and expressways (Access only at interchanges) with depressed medians should exhibit the following characteristics:

### Location

Any proposed maintenance turnaround should be placed at a location following the criteria below:

- Spacing should be at three-to-four-mile intervals (where interchange spacing is greater than five miles)
- Turnarounds may be placed at one or both ends of an interchange to facilitate snow removal operations
- Turnarounds should not be located within 1,500 feet of the end of the taper of a ramp entrance or exit lane
- Turnarounds should not be located within 1,500 feet of a structure
- Turnarounds should provide stopping sight distance along the freeway/expressway (see Section 3.2.2, "Stopping Sight Distance", in Chapter 3 of the *Green Book* (Ref. 10.2))

### Geometrics

- The turnaround width should be 40 feet
- The turnaround will be surfaced with type and thickness of surfacing determined by **M&R**
- The turnaround should provide a cross-slope of 2%
- The grade of the turnaround should be -2% towards the center of the median
- The sideslopes of the turnaround should be 1:10 or flatter
- If median barriers are present, crashworthy terminals will be provided (see Chapter Nine: Guardrail and Roadside Barriers, Section 6, of this manual)

### Drainage

- Drainage should be reviewed to determine if the turnaround would impede flows within the median
- Turnarounds should be placed adjacent to median drains to ensure proper drainage; if no median drain exists, a median drain should be constructed, or a culvert should be installed

For additional information, see Section 8.3.2, "Medians", in Chapter 8 of the *Green Book* (Ref. 10.2) and the Standard/Special Plans Book (Ref. 10.4), Typical X-Sections 1910 and 1911.

## 12. UTILITIES

For additional information, see Chapter Seventeen: Resurfacing, Restoration and Rehabilitation (3R) Projects, Section 10.F, of this manual.

### 12.A Utility Liaison

Highway construction projects frequently require the revision and relocation of utilities. The **Utilities Unit of Roadway (Utilities Unit)** is responsible for providing liaison with public and privately owned utilities. This includes:

- Reviewing plans and performing field inspections to determine utility ownership and identify potential conflicts
- Providing utility input to help determine the most satisfactory and economical location or design adjustments versus utility adjustments
- Requesting input from utility companies and reviewing and approving their plans, specifications, and estimates
- Coordinating with municipalities for the rehabilitation of their owned and operated utilities on highway projects
- Reviewing utility billings and submitting them for payment and subsequent audit review

It is the responsibility of the roadway designer to work with the **Utilities Unit** in identifying and resolving utility conflicts. As soon as the designer identifies a possible conflict, he/she should meet with the **Utilities Unit** to determine the best rehabilitation procedure. If utility relocation is required, the **Utilities Unit** will notify the utility owner.

The **Utilities Unit** submits preliminary design plans, received from the roadway designer, to the utility owners at the time of plan-in-hand, for the identification of any utilities not shown on the plans. When the **Utilities Unit** sends plans to the utility owners on a project, they will furnish **Roadway** with a memo indicating when and to whom the plans were sent. At the plan-in-hand it is important that the roadway designer notes any utilities not located on the plans and identifies any potential conflicts. As right-of-way appraisal plans are nearing completion, the **Utilities Unit** sends right-of-way and limits of construction plans to the utility owners for preparing utility rehabilitation plans and cost estimates. Throughout the development of the project it is very important that the roadway designer notifies the **Utility Coordinator** whenever design changes occur. This will enable proper coordination with the affected utility owners (See "Utility Rehabilitation Negotiations", Ref. 10.13). Failure to inform the **Utilities Unit** of design changes may result in a utility relocating their facility and then being informed they will have to move again because they are still in conflict with the proposed construction. This could result in a delay to the contractor and additional expense to the **State**.

### 12.B Utility Rehabilitation Plan Review

The **Utilities Unit** will submit utility rehabilitation plans, as the utility owners return them, to the **Roadway Design Unit Head** for review unless the utility work is minor. The **Utilities Coordinator** will have previously reviewed the plans and will indicate any comments from his/her review. The **Roadway Design Unit Head** and/or designer will review the plans and return them to the **Utilities Coordinator** with any comments regarding the plans on the transmittal letter received from utilities.

## 12.C City/County Utility Cost Reimbursement

Responsibility for determining cost sharing to relocate city utilities is also a joint effort by both the **Utilities Unit** and the appropriate **Roadway Section**. However, any financial commitment to a city for a utility relocation shall be submitted by the **Utilities Unit** in agreement form. Reimbursable costs represent the eligible non-betterment expenditures of the utility required to install, revise, and/or relocate utilities. Municipally owned utility facility non-betterment relocation costs are 100% reimbursable whether they are on public or private right-of-way inside the corporate limits. Outside the corporate limits the eligible reimbursement is based on the right-of-way/private easement criteria.

Not all utility relocation costs are reimbursable. Utilities located within existing state right-of-way that must be moved for a project are not eligible for reimbursement and the utility owner must bear the cost of the relocation expense. If a utility line is outside of existing state right-of-way and additional right-of-way is to be acquired necessitating relocation of the utility, the relocation expense is reimbursable. The utility may stay within the new right-of-way but must obtain a permit to occupy state right-of-way. The **Right-of-Way Division (ROW)** maintains a computerized listing of all utility permits by utility type in ARMS.

On all projects, especially federal-aid projects not on the state highway system, the **District Project Manager** shall notify **Roadway** or the **Secondary Roads Unit** and the proper **City** or **County Officials** (if necessary) if utility work not originally anticipated is required during construction. If the utility work is eligible for reimbursement and the **City/County** wants federal aid, the **City/County** should contact the **Urban Design Engineer** or the **Highway Local Liaison Coordinator**. The **District Project Manager** will coordinate with the utility involved to expedite the utility work to minimize delays to the construction contractor.

## 12.D Utility Accommodation on State Highway Right-of-Way

Utilities are permitted to occupy public highway right-of-way at the discretion of **NDOT**. On state highways, **NDOT** is responsible for regulating utility right-of-way occupancy. All requests to place utilities within state right-of-way are submitted to the **Utilities Unit**. See a [Policy for Accommodating Utilities on State Highway Right-of-Way](https://dot.nebraska.gov/media/d0bplnsz/utillaccom.pdf), (Ref. 10.14), (<https://dot.nebraska.gov/media/d0bplnsz/utillaccom.pdf>) for additional information.

Any underground utility facility that crosses a drainage course within the right-of-way must be installed a minimum of four feet below the flow line of the drainage structure or drainage course, whichever is lower. Underground utility lines that cannot be installed with minimum cover due to natural conditions or conflict with other utilities may be required to protect the lines with suitable bridging, concrete slab, casing or other appropriate means. Utility route and line markers shall be placed on the right-of-way line identifying the name, address, and telephone number of the utility owner in case of emergency.

### 12.D.1 Aerial Lines

Aerial electrical power and communication lines constructed within the public right-of-way must be constructed in accordance with the current National Electric Safety Code (Ref. 10.15). The alignment of the overhead lines shall be as near the right-of-way line and parallel to the highway centerline as is practicable, ignoring minor irregularities in the right-of-way line. Joint use of utility poles is encouraged to avoid placing additional poles within the right-of-way. All poles and anchors shall conform to the following horizontal clearances:

1. In rural areas, all rigid poles and anchors must be located beyond the Horizontal Clear Zone, right-of-way permitting, (See Nebraska Minimum Design Standards, Ref. 10.5). If sufficient right-of-way is not available, **NDOT** may require the use of breakaway design or a regrading of the right-of-way.
2. On urban or suburban highways with 45 mph or lower speed limits and rural cross-sections, all rigid poles and anchors shall be located at least 15 feet from the edge of the traveled way, preferably near the right-of-way line.
3. On city, town and urban highways with curbed sections, rigid poles and anchors may be located at the back of the sidewalk or at a minimum of six feet from the back of the curb where feasible.
4. Exceptions to these clearances may be made where curbside parking is permitted or where poles and anchors can be placed at locations behind guardrails, beyond deep ditches or on top of high banks, or at other similar locations that would not present additional hazards to the traveling public.

Poles located closer than the limits shown above should contain breakaway bases or other breakaway characteristics to permit the pole to collapse upon sharp impact or should be shielded. If poles are in urban conditions with high pedestrian traffic, breakaway bases should not be used (See the Roadside Design Guide, Ref. 10.11).

The following vertical clearances for utilities above the traveled way are required:

1. Aerial lines with 750 volts or less shall have a minimum clearance of 18 feet above the traveled way (the minimum clearance shall be measured from the high point of the roadway, including the shoulders).
2. Installation of aerial lines within and crossing public highway right-of-way and having 750 or more volts of electrical power shall comply with the regulations in the National Electric Safety Code (Ref.10.15) for vertical clearances and conductor sizes.

Longitudinal utility occupancy inside the fenced right-of-way of an Interstate or freeway is considered only as a "last resort" when no other feasible route can be followed by the utility facility or when such utility facility exclusively serves a highway facility. Specific details for each installation will be determined at the time the utility occupancy is authorized.

New aerial installations should be avoided at scenic locations and will be considered only if installation in alternative locations is unusually difficult and unreasonably costly, where installing the line underground is not technically or economically feasible, or if the installation can be made in such a manner that adequate attention to the visual qualities of the area will be addressed.

### 12.D.2 Underground Electrical Power and Communication Lines

Underground electrical power and communication lines constructed within highway right-of-way shall conform to the current electrical safety regulations (National Electric Safety Code, Ref. 10.15) and the Nebraska Standard Specifications for Highway Construction (Ref.10.12).

1. In villages and cities, the preferred location of parallel underground electrical power and communication lines installation is near the right-of-way line. They may be installed under the shoulder however this may cause possible conflicts with future construction.
2. On highways in villages and cities without sufficient right-of-way or a suitable location for underground lines outside of the traveled way, lines may be placed under the surfacing if it is determined to be in the best interest of the traveling public.
3. Installations of underground electrical power and communication lines may occupy a position near the toe of the fill slope or the top of back slope if insufficient right-of-way exists or if topography prohibits placement near the right-of-way line. **NDOT** shall designate the specific location of such facilities and any additional conditions concerning the right-of-way occupancy.
4. All manholes shall be placed outside of the traveled way where possible and shall not protrude more than four inches above the surrounding ground or shall comply with the horizontal clearances listed in Section 11.D.1 of this chapter.
5. Underground electrical power and communication lines within right-of-way with large cut and fill sections shall be placed at or near the toe of the fill or top of back slope.
6. Installation of underground electrical power and communication lines under the traveled portion of an existing highway must be performed by jacking, tunneling or dry boring from the toe of the fill slope to the toe of the opposite fill slope.
7. The utility shall be placed at a minimum depth of four-feet below the bottom elevation of the parallel road ditch or, in the absence of ditches, a minimum depth of cover of three-feet below the elevation of the natural ground. Additional cover may be required to protect the traveling public.
8. In areas with scenic designation, new underground utility installations may be permitted where they do not require extensive removal or alteration of trees or other natural features visible to the highway user or do not impair the visual quality of the lands being traversed.

### 12.D.3 Pipelines

Pipelines include sewer, water, gas, petroleum products, chemicals and irrigation lines. Approved materials for the construction of pipelines shall include cast iron, ductile iron, steel pipe with protective coating, vitrified clay, concrete, specially treated concrete, composite pipe (truss pipe), copper pipe and flexible pipe with some restrictions. Pipeline and casing construction within highway right-of-way shall conform to current appropriate standards.

1. The preferred location of pipeline installation parallel to the highway is near the right-of-way line.
2. Installations within villages and cities may require the use of shoulders or driving lanes and should take into consideration the provisions discussed for underground electrical and communication lines in Section 11.D.2 of this chapter.
3. Where insufficient right-of-way or topographic features prevent pipeline installation near the right-of-way line, pipelines may be installed near the toe of the fill or top of back slope at locations designated by **NDOT**.
4. Pipelines located within right-of-way with large cut or fill sections shall be placed at or near the toe of the fill or top of back slope.
5. All manholes and shutoffs shall be placed outside of the traveled way where possible and shall not protrude more than four inches above the surrounding ground or shall comply with the horizontal clearances listed in Section 11.D.1 of this chapter.
6. The minimum depth of earth cover over pipelines shall be three feet unless polyvinyl chloride (PVC) pipe is used. PVC pipelines carrying liquids shall be installed a minimum depth of five-feet, PVC pipelines carrying natural gas shall be installed a minimum depth of three-feet, however additional cover may be required.
7. Backfill of pipeline trenches shall conform to the standard specifications (Nebraska Specifications for Highway Construction, Ref. 10.12).
8. All pipelines attached to structures shall be placed in a neat manner beneath the structure's floor and inside of the outer girders or beams or in cells specifically designed for the installation.

#### 12.D.4 Water Mains

Water mains shall be laid at least 10 feet horizontally from any existing or proposed storm sewer, sanitary sewer, or sanitary sewer force main. The distance shall be measured edge to edge. In cases where it is not practical to maintain a 10 foot separation, the **Nebr. Dept. of Health** may allow deviation on a case-by-case basis, if supported by data from the designer. Such deviation may allow installation of the water main closer to a sewer, provided that the water main is laid in a separate trench or on an undisturbed earth shelf located on one side of the sewer or at such an elevation that the bottom of the water main is at least 18 inches above the top of the sewer.

Water mains crossing storm sewers, sanitary sewers, or sanitary sewer force mains shall be laid to provide a minimum vertical distance of 18 inches between the outside of the water main and the outside of the sewer. This shall be the case whether the water main is above or below the sewer. At crossings, one full length of water pipe shall be located so that both joints will be as far from the sewer as possible. Special structural support for the water and sewer pipes may be required.

The **Nebr. Dept. of Health** must specifically approve any variance from the requirements of these instructions when it is impossible to obtain the specified separation distances. Where sewers are being installed and these instructions cannot be met, the sewer materials shall be water main pipe or equivalent and shall be pressure tested to ensure water tightness.

Water pipe shall not pass through or come into contact with any part of a sewer manhole. For additional information see [Recommended Standards for Water Works](#), (Ref. 10.16), ([2022 Recommended Standards for Water Works.pdf \(state.pa.us\)](#)).



### 13. ROADWAY LIGHTING

Roadway lighting systems on all **NDOT** projects will conform to the requirements of the **Illuminating Engineering Society of North America (IESNA)** Standard RP-8. The **Roadway Design Intelligent Transportation Systems/Lighting Unit (ITS/Lighting Unit)**, using the warrants as outlined in this manual and any lighting recommendation(s) from the project plan-in-hand report, is responsible for determining if roadway lighting is warranted for a project. If lighting is found to be warranted, the **ITS/Lighting Unit** is responsible for its design and inclusion into the project. The roadway designer shall promptly notify the **Lighting Engineer** if the plan-in-hand lighting recommendation is, in any manner, changed by the **District**.

#### 13.A Guidelines for the Installation Of Roadway Lighting

Highway projects that have existing roadway lighting will continue to have roadway lighting. City agreements will need to include the operational and maintenance costs of the system. Requests for new roadway lighting should be forwarded to the **Lighting Engineer**, who will conduct a study for each request received. If the results of the study satisfy the conditions of one of the following warrants **NDOT** may, subject to the availability of funds, add lighting to an already programmed project or schedule a lighting project to design and build a system at the requested location. The **ITS/Lighting Unit** will determine the type and style of the lighting system that will be provided. Even though a lighting request meets appropriate lighting warrants, the **State** is not obligated to provide roadway lighting. **NDOT** will own all lighting systems within state highway right-of-way.

##### 13.A.1 Urban Lighting

###### 13.A.1.a Warrants

- Warrant I Accident History (Continuous or Intersection):** The number of nighttime accidents (N) per year is greater than two times the number of daytime (D) accidents in a three-year accident history study with more than four nighttime accidents per year per intersection or per mile ( $N > 2 \times D$ , &  $N > 4$ ).
- Warrant II Traffic Signals:** All intersections warranting traffic signals will also warrant roadway lighting.
- Warrant III Two Way Left Turn Lane (TWLTL):** Continuous lighting may be warranted with a two way left turn lane when there is 80% or more of commercial lighting along the state highway and more than 15 driveways per mile. Consideration will be given to continuous lighting when the mainline curves have a radius of less than 573 feet with a two way left turn lane.
- Warrant IV Local Responsibility:** If none of the previous warrants are met the local governing authority (**City, Town, Village, or S.I.D.**) can choose to install lighting if sufficient benefits are found in the form of convenience, safety, policing, community promotion, or public relations. The local governing authority will pay 50% of the installation cost and 100% of the operation and maintenance cost of the lighting system.

### 13.A.1.b Festoon Outlets

Festoon outlets (electrical outlets for holiday decorations) will be installed on urban projects as a project cost with a prior written request from the **City/Village**. Festoon outlets will only be installed in the core business area. If additional festoon outlets are requested, their cost will be the sole responsibility off the **City/Village**.

### 13.A.1.c Costs

When roadway lighting is scheduled for an urban project, the **Roadway Unit Head** or designer will ensure that local government officials are aware that the maintenance and operating costs of the lighting system will be the sole responsibility of the **City/Village**. Maintenance and operating cost estimates should be obtained from the **ITS/Lighting Unit** and presented to the local officials, prior to the signing of an agreement, to allow the **City/Village** to plan and budget for the expense. The local officials should also be informed that the lighting design, in order to be complete, may include a few poles that are outside of their corporate limits that they will be asked to be responsible for. A signed covenant agreement is required before a public hearing can be scheduled.

Roadway lighting projects within corporate limits meeting lighting warrant I, II or III and NOT installed as part of a New or Reconstructed, 3R, or Maintenance project will have **City/Village** participation as follows:

The local governing authority will pay for 50% of the installation cost and 100% of the operation and maintenance costs of the lighting system.

Roadway lighting projects within corporate limits meeting lighting warrant I, II or III and installed as part of a New or Reconstructed, 3R, or Maintenance project will have **City/Village** participation as follows:

Installation will be a project cost. 100% of the operation and maintenance costs of the lighting system will be the responsibility of the local governing authority.

## 13.A.2 Rural Intersection Lighting

### 13.A.2.a Warrants

**Warrant A Accident History:** The number of nighttime accidents per year is greater than one-third the number of daytime accidents per year and the average number of nighttime accidents per year is greater than three in a three year accident history study, or since the intersection was last modified ( $N > D/3$ , &  $N > 3$ ).

**Warrant B ADT/Topography/Geometrics:** A current ADT greater than 2500 vehicles/day at the intersection (combine all traffic ADTs from all legs and divide by two, with a minimum 250 ADT at each leg) combined with two or more of the following conditions would be sufficient to warrant lighting:

1. Complex or unusual geometrics.
2. Intersection sight distance less than 660 feet.
3. Pedestrian traffic of more than 200 per day.
4. Confusing background lighting from adjacent development.
5. Raised medians on the mainline highway.

**Warrant C Traffic Signals:** All locations meeting warrants for traffic signals will warrant roadway lighting.

**Warrant D Local Responsibility:** If none of the warrants A, B, or C are met the local governing authority (**City, Town, Village, or S.I.D.**) can choose to install lighting if sufficient benefit is found in the form of convenience, safety, policing, community promotion, or public relations. The local governing authority will pay for 50% of the installation cost and 100% of the operation and maintenance costs of the lighting system.

**Warrant E Four-Lane Bypass:** Whenever a four-lane highway bypasses a **City, Town, or Village**, access roads which intersect the bypass but do not meet lighting warrants may have lighting installed as a project cost if the local governing authority feels that such lighting is necessary. The local governing authority is responsible for 100% of the operation and maintenance costs of the lighting system.

### 13.A.2.b Costs

Roadway lighting projects outside of corporate limits and meeting warrant A, B or C will require no **City/Village** participation. The **State** will assume total responsibility for the costs of installation, operation, and maintenance of the lighting system.

### 13.A.3 Rural Continuous Lighting

Rural continuous lighting is only warranted when it is an extension of a continuous urban lighting system being installed as part of an urban project and the lighting extension meets an urban lighting warrant. The installation of warranted lighting extensions will be a project cost and 100% of the operation and maintenance costs will be the responsibility of the **State**. If the extended lighting is at the request of the local governing authority, 100% of the operation and maintenance costs of the lighting system will be the responsibility of the local governing agency. **NDOT** will not pay for unwarranted rural continuous lighting located outside of the corporate limits and which was built at the request of the local governing authority.

### 13.A.4 Interchange Lighting

Warrants for interchange lighting on Interstates or Expressways will be as outlined in the **AASHTO** publication Roadway Lighting Design Guide (Ref. 10.8). The operational and maintenance costs of interchange lighting that falls within the corporate limits of a **City/Village** will be the sole responsibility of that **City or Village**. See **NDOT** Operating Instruction 60-11, "Municipal Cost Sharing" (Appendix B, "Selected **NDOT** Operating Instructions", of this manual) for additional information.

## 14. PARKING

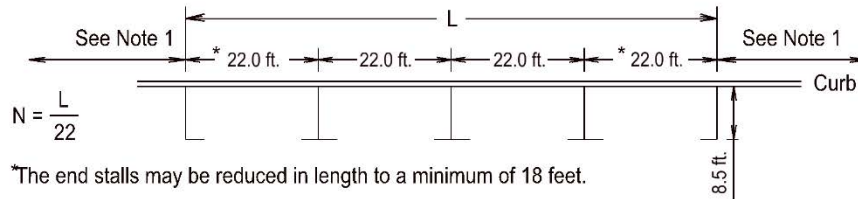
EXHIBITS 10.10 & 10.11 provide parking stall dimensions for curb/street parking and for parking lot/parking garage designs for passenger cars. The designer should check local standards before designing parking facilities. Parking modifications should be discussed with local officials, especially if existing parking is eliminated on the proposed facility. This should be done as early as possible in the design process. The designer should check with the **Traffic Engineering Division** if there is a need to provide for longer or wider vehicles. For further information see the Nebraska Revised Statutes, Chapter 60, Section 60-6,164 and Section 60-6,166 ([Nebraska Legislature - Revised Statutes Chapter 60](#))

### 14.A Accessible Parking

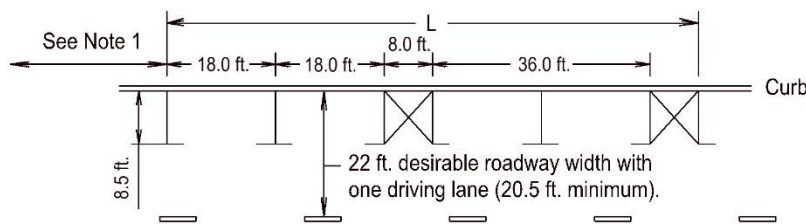
When the **Nebraska Department of Transportation** constructs or re-stripes parking spaces, it must provide accessible parking spaces as required by the Architectural and Transportation Barriers Compliance Board Accessibility Guidelines for Pedestrian Facilities in the Public Right-of-Way (2023) (Ref. 10.6) (<https://www.federalregister.gov/documents/2023/08/08/2023-16149/accessibility-guidelines-for-pedestrian-facilities-in-the-public-right-of-way>). Accessible parking spaces must be located to provide the shortest possible accessible route of travel to an accessible facility.

Additional guidance may be found in the U.S. Access Board Technical Guide “Parking Spaces” (<https://www.access-board.gov/guidelines-and-standards/buildings-and-sites/about-the-ada-standards/guide-to-the-ada-standards/chapter-5-parking>).

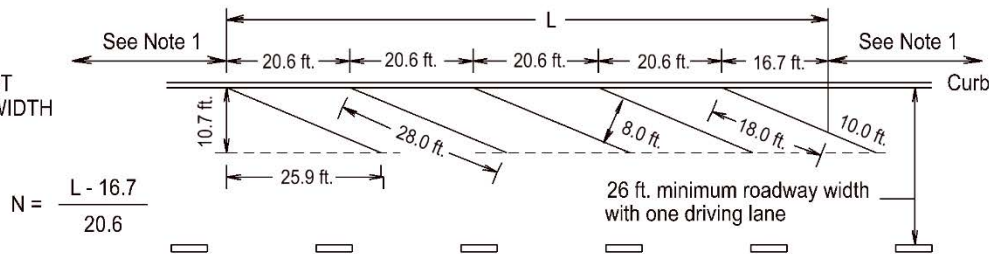
FOR CURB AND STREET PARKING



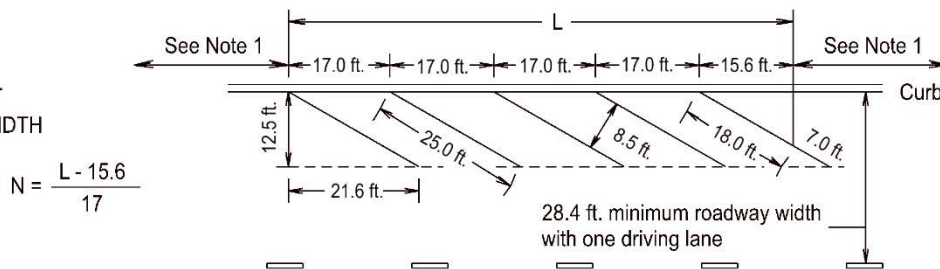
PARALLEL  
 8.5 FOOT  
 STALL WIDTH



22.5°  
 8.0 FOOT  
 STALL WIDTH



30°  
 8.5 FOOT  
 STALL WIDTH



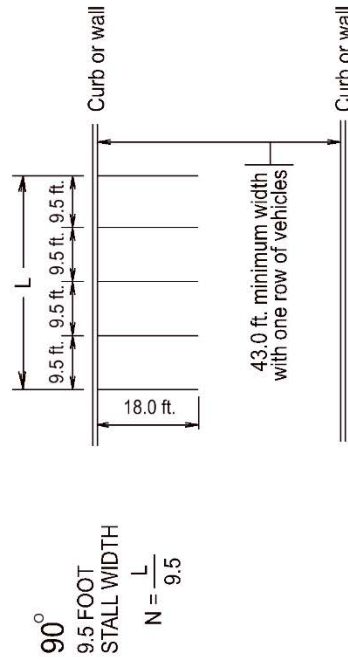
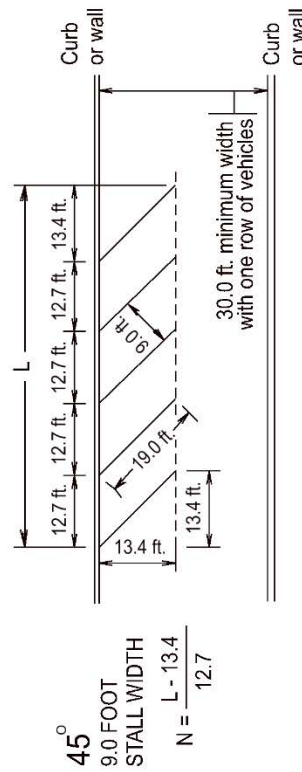
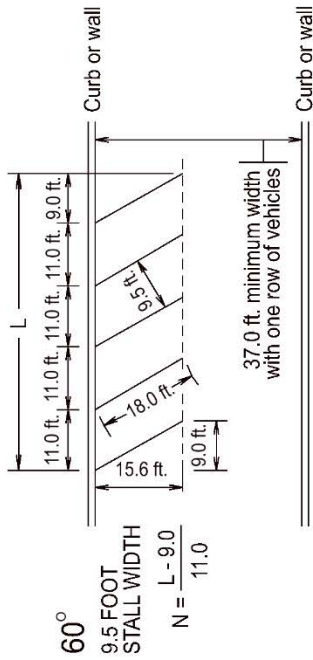
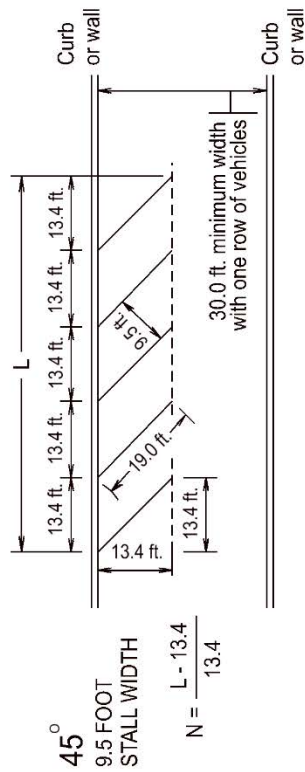
1. All parking shall be a minimum of 20 feet from the crosswalk, 30 feet from the stop sign, yield sign or traffic signal, and 15 feet from a fire hydrant. For other situations see Section 60-6, 166 Nebraska Rules of the Road.
2. White paint shall be used for marking; a 4 inch width is recommended for marking lines.

N = Number of stalls

L = Usable curb length

Exhibit 10.10 Parking Stall Dimensions for Curb and Street Parking

FOR PARKING LOT AND GARAGE PARKING



1. To provide for vehicles larger than cars, use wider stalls and wider aisles.
2. White paint shall be used for marking; a 4 inch width is recommended for marking lines.

N = Number of stalls

L = Usable parking length

Exhibit 10.11 Parking Stall Dimensions for Parking Lots and Garages

## 15. REFERENCES

- 10.1 Nebraska Department of Transportation, Design Process Outline (DPO), Current Edition. (<https://dot.nebraska.gov/business-center/design-consultant/>)
- 10.2 American Association of State Highway and Transportation Officials, A Policy on Geometric Design of Highways and Streets (Green Book), Washington, D.C., 2018.
- 10.3 Nebraska Department of Transportation, Drainage Design and Erosion Control Manual, Current Edition.
- 10.4 Nebraska Department of Transportation, Standard/Special Plans Book, Current Edition. (<https://dot.nebraska.gov/business-center/design-consultant/stand-spec-manual/>)
- 10.5 Board of Public Roads Classifications and Standards, Nebraska Minimum Design Standards (MDS), Current Edition. (<https://dot.nebraska.gov/media/1z1n5kmb/nac-428-rules-regs-nbcs.pdf>)
- 10.6 Architectural and Transportation Barriers Compliance Board, Accessibility Guidelines for Pedestrian Facilities in the Public Right-of-Way, Washington, D.C., August 8, 2023. (<https://www.federalregister.gov/documents/2023/08/08/2023-16149/accessibility-guidelines-for-pedestrian-facilities-in-the-public-right-of-way>)
- 10.7 American Association of State Highway and Transportation Officials, Guide for Erecting Mailboxes on Highways, Washington, D.C., 1985.
- 10.8 American Association of State Highway and Transportation Officials, Roadway Lighting Design Guide, Washington, D.C., 2018.
- 10.9 Nebraska. Laws, Statutes, Etc., Nebraska Highway and Bridge Law; Consisting Of Chapter 39, Highways And Bridges; Sections 49-801 And 49-802, Definitions And Rules of Construction; Article 6 Of Chapter 60, Nebraska Rules Of The Road. Revised Reissued Statutes of Nebraska, Current edition. (<https://nebraskalegisature.gov/laws/browse-statutes.php>)
- 10.10 U.S. Department of Justice, ADA Design Guide 1 – Restriping Parking Lots, Jan. 2002, Washington D.C. (<https://www.ada.gov/resources/restriping-parking-spaces/>)
- 10.11 American Association of State Highway and Transportation Officials, Roadside Design Guide, Washington, D.C., 2011.
- 10.12 State of Nebraska Department of Transportation, Standard Specifications for Highway Construction (Spec Book), 2017 (<https://dot.nebraska.gov/media/g4qp4y0d/2017-specbook.pdf>)
- 10.13 Nebraska Department of Transportation, "Utility Rehabilitation Negotiations," Operating Instruction 45-1, December 17, 1993.

- 10.14 Nebraska Department of Transportation, Policy for Accommodating Utilities on State Highway Right-of-Way, Current Edition.  
(<https://dot.nebraska.gov/media/d0bplnsz/utilaccom.pdf>)
- 10.15 Institute of Electrical and Electronic Engineers, Inc., National Electric Safety Code, New York, NY.
- 10.16 Great Lakes – Upper Mississippi River Board of State and Provincial Public Health and Environmental Managers, Recommended Standards for Water Works, 2022  
([2022 Recommended Standards for Water Works.pdf \(state.pa.us\)](https://www.state.pa.us/2022-Recommended-Standards-for-Water-Works.pdf))



The information contained in Chapter Eleven: Highway Plans Assembly, dated May 2022, has been updated to reflect the October 2023 Errata. The errata addresses errors, changes in procedure, changes in NDOT department titles, changes in other Roadway Design Manual chapters and other reference material citations occurring since the latest publication of this chapter.

Chapter Eleven presents guidance for the design of New and Reconstructed and 3R projects; additional design guidance for 3R projects is provided in Chapter Seventeen.

## Chapter Eleven

# Highway Plans Assembly

This chapter pertains to the assembly and indexing of the project plans. There is also a brief description of each type of plan sheet that is to be indexed and general information that may be useful in preparing the sheets.

Refer to the current versions of the CADD Policy and the Design Process Outline (DPO) (Ref. 11.1), both of which may be found at (<https://dot.nebraska.gov/business-center/design-consultant/>), under “Design Documentation”, for information related to project plan preparation.

### 1. DESIGN PLANS

There are several types of project plans which occur at various stages of roadway design. The roadway designer should furnish the **Roadway Design Plans Development Unit (PDU) Highway Design Technician** with the information required to produce plans at each stage of the project. See the *DPO* (Ref. 11.1) for the plan information requirements. The various project plan types are:

- Preliminary Design Plans (used for the plan-in-hand field inspection).
- Functional Plans (required for design public hearings).
- Design Detail Plans (used to design the project right-of-way).
- Design Plans to Utilities (used to determine impacts to utilities)
- Plans for Construction (Prelim and Final PS&E Plans, the **PS&E** turn-in and contract plans).

The plans should be thoroughly checked for completeness, accuracy, and formatting by the **Highway Design Technician**, the roadway designer, the **Roadway Design Unit Head (Unit Head)**, and the **Roadway Design Plan Quality & Standards Engineer** at each of these plan stages.

The notifications of the availability of the design plans are given in EXHIBIT 11.2.

The “Roadway Base Files” (Clarity Task 5235) show the topography and roadway alignment(s) (“Planning Alignment”, Clarity Task 5240), which are plotted from either a project survey or from the as-built plans of previous projects. The survey information is given to the roadway designer and **PDU Unit Head** by the **Geodetic Survey Section** in the **Project Scoping Section** of the **Project Development Division (PDD)** before the roadway designer creates the alignment. The project is then assigned to a **Highway Design Technician** who will assist the roadway designer

in sheet creation. The existing vertical alignment for the project centerline is required if plan and profile sheets are being requested (See Section 4.L of this chapter). The roadway base files will include:

- Draft Topography file
- Location Map
- Environmental Feature file
- Title and Index sheet file
- Typical Cross-Section sheet file
- Aerial or Environmental notes and sheets files
- Horizontal alignment and control point sheet files
- General information notes and sheets files
- Plan and Profile notes and sheets files
- Utility notes and sheets files
- Special Plan notes and sheets files

#### **1.A Preliminary Design Plans (PIH Plans) (Phase 3: Design – Activity 5300)**

Preliminary Design Plans are the initial project plans sheets used to produce the “Status 30 Cost Estimate” (Clarity Task 5368) and on the “Plan-in-Hand Visit” (Clarity Task 5380). The roadway designer will create the plan set and send it to the **Highway Design Technician**, who will check the plans for quality assurance and create the sheet files as outlined in the *DPO* (Ref. 11.1, “Design Files (PIH Plans)”, Clarity Task 5354) and in the CADD Policy.

The Environmental or Aerial Sheets (See Section 4.E of this chapter) will be developed at this stage of the project.

#### **1.B Functional Design Plans (Phase 4: Environmental Approval – Activity 5400)**

Functional Design Plans are required **only** if there is a Design Public (NEPA) Hearing and for the “Status 40 Cost Estimate”. The project design should be approximately 75% to 80% complete by this milestone. The roadway designer should:

- Coordinate with the **Communications Division** regarding the information needed for the meeting as described in the *DPO* (Ref. 11.1), “Design Prep for Public Meeting”, Clarity Task Code 5338.
- Allow three months lead time to prepare the plans and exhibits for a Design Public Hearing.

### 1.C Design Detail Plans (Phase 5: Plan Details – Activity 5500)

Design Detail Plans show the limits-of-construction used to design the right-of-way and easements required to build the project and to determine environmental impacts. The roadway designer will incorporate the approved alterations from the Design Public Hearing, if held, and right-of-way negotiations into the design and will provide the **Highway Design Technician** with the completed plan set for a standards check as described in the *DPO* (Ref. 11.1, “Plan Details (Design Detail Files)”, Clarity Task 5532). The roadway designer will use the design plans to produce the “Status 45 Cost Estimate”, Clarity Task 5584.

### 1.D Design Plans to Utility Unit (Phase 6: R.O.W. – Activity 5600)

The Design Plans sent to the **Roadway Design Utility Coordinators** (see the *DPO* (Ref. 11.1), “Design Plans to Utility Unit”, Clarity Task 5614) will have sufficient detail for the **Utility Companies/Consultants** to determine if their facilities are impacted, and if so, to what extent. Large Scale (J) Sheets (See Section 4.J of this Chapter) may be included if required to provide sufficient detail.

The roadway designer will provide the latest details for, but not limited to:

- Project location map
- Horizontal alignment
- Vertical alignment
- Roadway cross-sections
- Ditches (including special ditches)
- Drainage structures
- Culvert cross-sections
- Special designs (if there is utility involvement)
- Detours, temporary roads, crossovers
- Frontage roads, side roads, etc.
- Driveways and other accesses
- Driveway culverts
- Sidewalks, bikeways, shared-use paths
- Medians, curbs & gutters, etc.
- Embankment widening for guardrail installations
- Dikes, dams, etc.
- “Do Not Disturb” environmental areas
- Wetlands mitigation
- Removals
- Lighting
- Traffic signals
- Overhead signs (including foundations)
- Bridges & pedestrian structures
- Retaining wall (approximate height and location)
- Limits of construction (from project centerline to be used)
- All above and underground utility facilities (power, telephone, pipelines, gas, cable, etc.)
- Above ground utility structures (telephone poles, power poles, telephone pedestals, power pedestals, manholes, etc.) Must have the station and offset from the centerline to be used
- Centerline crossing station of all underground pipelines

### 1.D.1 Pre-PS&E Plans (Phase 7: Plan Package – Activity 5700)

Pre-PS&E Plans include all plans shown in the Design Detail Plans (See Section 1.C of this chapter). The creation of the Pre-PS&E Plans starts the PS&E Turn-in process. All changes to the project since the completion of the Design Detail Plans shall be reflected in the Pre-PS&E Plans. The Pre-PS&E Plans are used by the **Materials and Research Division (M&R)**, **Traffic Engineering Division**, and the **PDD Roadside Development & Compliance Unit (RDC)** to create the PS&E Turn-in package.

### 1.E Plans for Construction

Plans for Construction are the plans which will be let to contract. The Plans for Construction will have any corrections made prior to submission to the **Plans, Specifications and Estimates Unit (PS&E)** in the **Construction Division (Construction)**.

**PDU** will create two different sets of plans for construction: a PS&E Preliminary set and a PS&E Plans set. The prelim set will not have the engineer's seals or the "Plans not Final" (PNF) cell displayed. **PDU** will place the "Preliminary" watermark on this set after its completion prior to being uploaded to OnBase. The final set will not have the "Plans Not Final (PNF) cell displayed, but it will have the engineer's seals displayed. This set will be signed by the engineer prior to being uploaded to OnBase.

#### 1.E.1 PS&E Plans (Phase 7: Plan Package – Activity 5700)

The roadway designer will create the "PS&E Preliminary Plan Package" for **PS&E** using these plans (See the *DPO*, Ref. 11.1, "Plan Package Design Modification for PS&E", Clarity Task 5765). The roadway designer should verify that the appearance of all of the project plans (including those from the **Bridge Division (Bridge)**, **Traffic Engineering Division (Traffic Engineering)**, **Right-of-Way Division (ROW)**, **Materials and Research Division (M&R)**, etc.) is uniform and consistent, containing the information required for the construction of the project. The use of duplicate data and cross references should be avoided; this is unnecessary and only complicates the task of assembling, checking, and revising the plans. The CADD files should be locked to prevent unauthorized changes to the plans.

#### 1.E.2 PS&E Letting Plans (Phase 8: Letting – Activity 5800)

**PS&E** will submit their blue-line corrections to the roadway designer to complete the corrections (See the *DPO*, Ref. 11.1, "PS&E Corrections", Clarity Task 5845). When the design plans have been submitted to **PS&E** the CADD files should be locked to prevent unauthorized changes to the contract plans (See the *DPO*, Ref. 11.1, "Blue Lines Submitted to PS&E", Clarity Task 5850).

Once the plans have been advertised for letting, **they are considered legal documents**. Between the time that a project has been advertised for letting and it is let to contract, requests to the **Roadway Design Division** for plans and/or electronic files will be forwarded to the **Highway Construction Scheduling Manager in Construction**. Changes to the plans after they have been advertised for letting must be processed as a plan revision, following the guidelines outlined in Section 7 of this chapter.

## 2. STANDARD PLANS, SPECIAL PLANS, AND DETAILS

The Standard/Special Plans Book (*Standard Plans*) (<https://dot.nebraska.gov/business-center/design-consultant/stand-spec-manual/>) (Ref. 11.2) contains Standard Plans, Special Plans, Standard Typical X-Sections, Standard Details, Information Plans, and Design Guides. The Standard Plans contained in the *Standard Plans* (Ref. 11.2) require the review and approval of the **Roadway Design Standard Plans Committee** and formal approval by the **Federal Highway Administration (FHWA)**. The other plan types are reviewed for approval by the **Standard Plans Committee**, with review and input from **FHWA**. This book should be referred to during the design of the project.

### 2.A Standard Plans

Standard Plans are plans which are in common use on a multitude of projects, such as curb inlets. Standard Plans have been reviewed by, and have received approval from, the **Nebraska Department of Transportation (NDOT)** and the **FHWA**.

The Standard Plans applicable to a particular project are listed, in numerical order, under the “Index of Sheets” on the plan set Title Sheet (See Section 4.A of this chapter). The roadway designer will provide a list of Standard Plans required for the project to **PDU**. These Standard Plans are submitted with the design plan set pdf to **PS&E**. The Standard Plans are updated periodically; it is the responsibility of the roadway designer to verify that the Standard Plan number is current.

Changes or alterations to the Standard Plans by the roadway designer are not allowed. If a designer believes that a Standard Plan needs to be changed or updated, the desired change must be brought to the attention of the **Standard Plans Committee** through the **Roadway Design Plan Quality & Standards Engineer**.

### 2.B Standardized Special Plans

A Standardized Special Plan may be used on multiple projects. The roadway designer will contact **PDU** or the **PDD RDC** to have the required Standardized Special Plan(s) inserted into the design plan set and into the project file. The roadway designer must verify that the Standardized Special Plans required for a project are included with the Plans for Construction sets (See Section 1.E of this chapter).

### 2.C Special Plans

Special Plans are plans which are either subject to frequent change or are unique to one project or location (e.g. guardrail installation plans). Certain Special Plans must be requested from the **Bridge Division Special Projects Unit** during Plan Details (See the *DPO*, Ref. 11.1, Activity 5500, “RD Request Bridge Special Plans”, Clarity Task 5516). The roadway designer should request concrete box culverts using the “Concrete Box Culvert Request Sheet”, NDOT Form 67. Retaining Walls, Headwalls, etc. may be requested using the “Custom Special Plan Request Sheet”, NDOT Form 66. Custom Special Plans must be included in the Plans for Construction sets (See Section 1.E of this chapter).

## **2.D      Standard Typical Cross-Sections**

The Standard Typical Cross-Sections are a collection of standard details, such as “Rural Intersections and Driveways” and “Joint/Pavement Repair”. Depending on the size of the detail, the information found on the Standard Typical Cross-Sections may be included in the plan package as a Typical Cross-Section Sheet (See Section 4.B of this chapter) or the details may be added to a General Information Sheet (See Section 4.G of this chapter). Standard Typical Cross-Section sheets and details are available from **PDU** and must be included in the Plans for Construction sets (See Section 1.E of this chapter).

## **2.E      Information**

The Information section of the *Standard Plans* (Ref. 11.2) contains details that remain constant from project to project, such as contour cultivation. Details from the Information section shall be placed on the General Information Sheets (See Section 4.G of this chapter). These details are available from **PDU** for inclusion in the Plans for Construction sets (See Section 1.E of this chapter).

## **2.F      Standard Details**

Standard Details are items which are not drawn to a large enough scale to fill a plan sheet or are items which may not be paid for directly. Standard Details are normally placed on the General Information Sheet (See Section 4.G of this chapter), the Typical Cross-Section Sheet (See Section 4.B of this chapter), or the guardrail installation special plan. Existing Standard Details can be used to create a plan sheet containing an assemblage of details, such as for concrete pavement repair.

## **2.G      Design Guides**

Design Guides provide details to aid the roadway designer and the **Highway Design Technician** in developing the project design and plans. These details are not generally included in the design plan sets (See Section 1 of this chapter).

### 3. STANDARD FORMATS

Clarity and consistency are essential to good communication. Information regarding the levels, line styles, and line weights to be used in plan preparation can be found in the current version of the CADD Policy.

#### 3.A Plan Border Sheets

NDOT has the basic types of plan border sheets available in ProjectWise within NDOT's active workspace.

The available sheets include:

- Typical Cross-Section
- Aerial Photo
- Control Points
- General Information
- Large Scale Plans
- Plan and Profile
- "Piggyback" Plan over Plan
- Cross-Section (for Drainage Sections, etc.)

#### 3.B Standard Symbols

Most of the symbology and patterning commonly used in the roadway design plans have been standardized and may be found in ProjectWise within NDOT's active workspace.

#### 3.C Construction Notes

The Construction Notes and Tabular Notes contain numerous cells used for construction notes. These cells shall only be modified to fill in the underscores. Any other modification shall be approved by **PS&E**.

Tabular notes are used on the Large-Scale Sheets (See Section 4.J of this chapter) and the General Information Sheets (See Section 4.G of this chapter).

Individual construction notes are used on Plan and Profile or on "Piggyback" Plan over Plan Sheets (See Sections 4.L and 5 of this chapter). The construction notes should be framed in with a leader line drawn, except for existing pipe note descriptions. Notes for pipe culverts that are to be used in place do not need to be framed in and do not require a leader line (nor does the note need to state "Use in Place").

Occasionally a unique construction note must be used. In this situation, coordinate with **PS&E** to create the note that is needed. Acceptable abbreviations for use in the construction or tabular notes are listed in the Glossary.

### 3.D Horizontal Alignment Data

The horizontal alignment data for all sheets except for alignment sheet should be represented as follows:

- Represent the stationed project centerline (CL) by a solid line with tic marks, indicating a station, every 100 feet.
- Label every station that is divisible by 5 for the plan views of the 1" = 100' and 1" = 50' scales (e.g. 220, 225, 230).
- Label every station on the 1" = 20' scale (e.g. 220, 221, 222).

The alignment sheets shall show the following information:

- Represent the stationed project centerline (CL) by a solid line with tic marks, indicating a station, every 100 feet.
- Identify the horizontal curve points (PI, PC, PT, TS, SC, CS, and ST) by station.
- Label every station that is divisible by 5 for the plan views of the 1" = 100'.
- The curve radius (R) will be shown to the nearest 0.01 foot.
- Deflection angles are shown to the nearest 0.01 second. The other curve data will be shown to the nearest 0.01 foot.

The following curve data items are to be listed near the PI's in this order:

#### **Circular Curve**

<b>PI</b>	Point of Intersection
<b>Δ</b>	Deflection Angle
<b>T</b>	Tangent Length
<b>R</b>	Radius of Curve
<b>PC</b>	Point of Curvature
<b>PT</b>	Point of Tangent

#### **Spiral Curve**

<b>PI</b>	Point of Intersection
<b>Δ</b>	Deflection Angle
<b>T</b>	Tangent Length
<b>Δc</b>	Circular Deflection Angle
<b>Lc</b>	Length of Circular Curve
<b>Θs</b>	Spiral Deflection Angle
<b>Ls</b>	Length of Spiral Curve
<b>Lt</b>	Long Tangent for Spiral Curve
<b>St</b>	Short Tangent for Spiral Curve
<b>E</b>	External
<b>TS</b>	Tangent to Spiral
<b>SC</b>	Spiral to Curve
<b>CS</b>	Curve to Spiral
<b>ST</b>	Spiral to Tangent

For further information, see Chapter Three: Roadway Alignment, Section 2, of this manual.



### 3.E Vertical Alignment Data

Vertical Alignment Data should be presented as follows:

#### **Profile:**

- The existing ground line will be shown along the project centerline.
- The design profile will be placed in relation to the existing ground line.
- Proposed vertical alignment will not be shown in overlay areas (overlay projects are not normally drawn on plan and profile sheets unless special ditches need to be shown).

#### **Stationing:**

- Note every station along the bottom of the profile. Stationing should fall directly below the dominant vertical grid lines, for example:  
150 1 2 3 4 155 6 7 8 9 160 etc.
- If required, station equations are to be clearly shown in the profile view (show a gap in the profile line, if needed).

#### **Elevations:**

- The existing centerline elevation text is placed vertically, directly above the datum elevation line and to the left side of the vertical grid line and will be given to the nearest 0.01 foot.
- The design elevation text is placed vertically, offset above the existing ground elevations and to the right of the vertical grid line and will be given to the nearest 0.01 foot.
- Reference elevations will be shown as even 10 feet intervals in the columns on each side of the profile sheet (labeled on the dominant horizontal grid lines).
- The datum elevation will be shown in the lower left corner of the profile sheet, 1 grid up from the bottom.

#### **Vertical Curve Labeling:**

- VPC's and VPT's will be indicated by a small circle (cell) on the grade line. No further information is required.
- VPI's will be indicated by a small triangle (cell) at the intersection of the dashed tangent lines. The notes for the VPI's will indicate the following:
  - VPI Sta. (normally located at a vertical grid line or VPI Sta.)
  - Elev. = (elevation at the VPI)
  - L = (length of the vertical curve)
- Tangent slope percentages will be labeled to four decimal places.

#### **Special Ditches:**

- Special ditch lengths of less than 150 feet will not be shown on the plans (See Chapter Six: The Typical Roadway Cross-Section, Section 10.B, of this manual).
- If the profile portion of the plan sheet is heavily congested, the special ditch information may be presented on the General Information Sheet in tabular form (if one profile sheet requires that the special ditch table be placed on the General Information Sheet, then the information for all special ditches shall be placed there).

For further information, see Chapter Three: Roadway Alignment, Section 3, of this manual.

### 3.F Drainage and Hydraulic Information

The build notes and drainage and hydraulic information will be shown in the plan set as noted below. When the hydraulic information is given, the items to be shown on the plans are:

- Q<sub>xx</sub>** - Peak flow in cfs (cubic feet per second)  
(xx = subscript for the design period, e.g. 50)
- DA** - Drainage Area (in acres)
- HW** - Head Water in feet above the flow line of the inlet

#### 3.F.1 **New and Reconstructed Projects**

**New Culverts:** The drainage and hydraulic information is placed in the culvert construction notes on the Plan Sheets (See Sections 4.J and 4.L of this chapter) and on the Drainage Structure Cross-Sections (See Section 4.R of this chapter). This includes drop pipes and driveway culvert pipes requiring pipes larger than the standard 24-inch diameter.

**Existing Culverts Used-in-Place or Extended:** These culverts will be analyzed. The drainage and hydraulic information is placed in the culvert construction notes on the Plan Sheets (See Sections 4.J and 4.L of this chapter) and on the Drainage Structure Cross-Sections (See Section 4.R of this chapter). Culverts that are used in place will be noted on the culvert cross-section sheets.

#### 3.F.2 **3R Projects**

**New Culverts:** The drainage and hydraulic information is placed in the culvert construction notes on the Plan Sheets (See Sections 4.J and 4.L of this chapter) and on the Drainage Structure Cross-Sections (See Section 4.R of this chapter). This includes drop pipes and driveway culvert pipes requiring pipes larger than the standard 24-inch diameter.

**Existing Culverts Used-in-Place or Extended:** Unless a hydraulic analysis has been completed, only build notes and culvert cross-sections will be required. If a hydraulic analysis shows that a new pipe is required, the procedure for new culverts will be followed. Culverts that are used in place will be noted on the culvert cross-section sheets.

For additional information see Chapter Seventeen: Resurfacing, Restoration and Rehabilitation (3R) Projects, Section 17, of this manual.

### **3.G      Plan Sheet Scales**

#### **3.G.1      Urban**

##### Plan and Profile Sheets:

Horizontal: 1" = 50'

Vertical: 1" = 10'

##### Design Detail Plan Sheets:

The Design Detail plan sheets are normally scaled at 1" = 20', especially if curb ramps, storm sewers, and grades are present.

For a project with less complexity, a scale of 1" = 50' may be used.

#### **3.G.2      Rural**

##### Plan and Profile Sheets:

Horizontal: 1" = 100'

Vertical: 1" = 10'

##### "Piggyback" Plan over Plan Sheets:

Rural projects are usually scaled at 1" = 100'

##### Large Scale Plan Sheets:

Large scale plan sheets may be prepared for rural projects to show details of construction more clearly, such as roadway/intersection geometry, raised islands, grades, etc. These large scale sheets are normally scaled at 1" = 20'; a 1" = 50' scale may be used for projects with less complexity.

## **4.            PLAN SET ORGANIZATION**

Depending on the type and scope of a specific project, each set of contract plans will contain plan sheets selected from and in the order presented in EXHIBIT 11.1.

Sheet Number & Order	Plan Sheet (As Required)	Created By	Sheet Description	Sheets Required for Plan Sets				
				PH	Functional *	Design Detail	Utility Plans	PS&E
A	Title Sheet	PDU	See Section 4.A	X	X	X	X	X
B	Typical Cross-Sections	PDU	See Section 4.B	X	X	X	X	X
C	Summary of Quantities	PDU	See Section 4.C					X
D	Summary of Soil and Materials Survey Information	M&R	See Section 4.D					X
E	Aerial Sheets including Environmental Items (when applicable) includes Sensitive Areas	PDU	See Section 4.E	X	X	X	X	X
F	Horizontal Alignment and Control Points	PDU	See Section 4.F	X	X	X	X	X
G	General Information Sheets (Access Cross Sheets, includes Restricted Areas)	PDU	See Section 4.G	X	X	X	X	X
H	Phasing Plans	PDU	See Section 4.H	X	X	X	X	X
J1 Thru J	Large Scale Plans:	PDU	See Section 4.J					
J	Geometrics and Grades	PDU	See Section 4.J			X	X	X
J	Fencing	PDU	See Section 4.J			X	X	X
J	Drainage	PDU	See Section 4.J			X	X	X
J	Joints	PDU	See Section 4.J			X	X	X
J	Construction & Removal (on separate sheets if necessary)	PDU	See Section 4.J			X	X	X
J	Sidewalks and Curb Ramps	PDU	See Section 4.J			X	X	X
K	Utility Relocation	Consultant/ Designer/ Municipality	See Section 4.K			X	X	X
L	Plan and Profile or Plan Over Plan Sheets	PDU	See Section 4.L	X	X	X	X	X
M	Traffic Plans	Traffic	See Section 4.M					X
N	Roadway Lighting Plans	Lighting/PDU	See Section 4.N				X	X
O	Intelligent Transportation Project Plans	ITS/PDU	See Section 4.O and Chapter Fourteen: Traffic, Section 5				X	X
P	SWPPP & Landscaping and Erosion Control & Sediment Control w/Wetland Areas, includes Restricted Areas	Project Develop.	See Section 4.P			X	X	X
Q	Earthwork Data Sheets	Designer	See Section 4.Q					X
R	Drainage Structure Cross-Section Sheets	Designer	See Section 4.R	X	X	X	X	X
S	Bridge Plans (Bridge, Approach Slab, Paving Section)	Bridge	See Section 4.S					X
T	Special Plans from Bridge (CBC, etc.)	Bridge	See Sections 2.C & 4.T					X
U	Special Plans from Roadway (Area Inlets, Guardrail etc.)	Designer/PDU	See Sections 2.B, 2.C & 4.U					X
V	Other Plans as Needed		See Section 2.C & 4.V					
W1 Thru W	Right-of-Way Plans	R.O.W.	See Sect. 4.W and Chap. Fifteen: <u>Right-of-Way</u>					
	Ownership	R.O.W.	Chap. Fifteen, Sect. 2.B	X	X			
	Appraisal	R.O.W.	Chap. Fifteen, Sect. 2.D			X	X	
	PS&E Turn-in	R.O.W.	Chap. Fifteen, Sect. 2.F					X
X1 Thru X	Roadway Cross-Sections	Designer	See Section 4.X	X	X	X	X	X
Std. Plans	Standard Plans	PDU	See Section 2.A					X

\* Functional Plans are only required if a Design Public Hearing will be held.

**Exhibit 11.1 Plan Set Sheet Organization**

**Clarity Task 5317: Plan-In-Hand Plan Distribution**

Include location map & typical section (use "Preliminary Plans" cell)

Please note any substantial changes from the Engineering Review on the plans transmittal letter and the notice of plans availability.

Print four half-size plans for use on the Plan-In-Hand field inspection

Notify the following that the Roadway Design PIH Plan Set is available in OnBase and give file location (Distribute/notify 2 weeks prior to PIH. Railroad personnel need 5 weeks' notice to attend PIH)

**NDOT Division of Aeronautics** (*if near an airport, See Chapter Ten, Section 3, of this manual*)

Division Head

**Bridge**

Division Engineer

**Communications**

Public Involvement Coordinator/Highway Commission Secretary

**Construction**

Highway Construction Scheduling Manager

**District** (*Include location of PCM 30 Minutes*)

District Engineer

District Construction Engineer

Operations and Maintenance Manager

Project Delivery Engineer

Project Manager

**Highway Archeologist**

**Local Assistance**

Rail Highway Liaison Manager (*if applicable*)

**Materials & Research**

Division Engineer

Geotechnical Engineer

Pavement Design Engineer

Assistant Pavement Design Engineer

Pavement Designer

**Project Development**

Environmental Section Manager

Technical Resources Unit Supervisor

Environmental Documents Unit Manager

Environmental Project Manager

Roadside Development & Compliance Unit Supervisor

Scoping Section Engineer

**Project Scheduling & Program Management**

Division Engineer

Program Analyst

Program Coordinator

**Right-Of-Way**

Design Engineer

Project Manager

Designer

**Roadway Design**

PDU Unit Head

ITS/Lighting Unit Head

Utilities Unit Head

Utilities Coordinator

**Strategic Planning**

Highway Traffic Data Collection Supervisor

**Traffic Engineering** (*Include location of PCM 30 Minutes*)

Division Engineer

Optional Notifications/Distributions (if applicable)

Notify the following that the Plan Set is available in OnBase and give file location

**FHWA** (only on Interstate New and Reconstruction or on FHWA Risk Based Projects for Design)

Division Administrator

Engineering & Operations Team Leader

Transportation Engineer

Transmit Plans

**City** (1 – ½ size plan)

**County** (1 – ½ size plan)

**Other**

**Clarity Task 5380: Plan-In-Hand Visit**

Invite to the Plan-in-Hand

1. **Bridge** - Bridge Personnel (if bridges on project)
2. **R.O.W.** - R.O.W. Designer, ROW Design Engineer, & ROW Project Manager (if buying ROW)
3. **Materials & Research** – Geotechnical Engineer
4. **District** – DE, DCE, Operations & Maintenance Manager, Project Manager
5. **Local Assistance** - Rail Highway Liaison Manager  
(RR personnel need 5 weeks advance notice to attend PIH)
6. **Project Development** - Wetlands Coordinator, Roadside Development & Compliance Unit Manager, Technical Resources Unit Supervisor, Environmental Analyst Supervisor and, if applicable, the Environmental Section Manager (New or Reconstructed projects only)
7. **Project Development** – Assigned Environmental Project Manager (if applicable) Please verify your Project Manager in Clarity before sending invitations.
8. **Project Development** – T&E Biologist (if applicable)
9. **Project Development** - Scoping Engineer
10. **Roadway Design** - Utilities Coordinator through Utilities Unit Head
11. **FHWA** – Division Administrator (only Interstate New and Reconstruction or RBP projects)
12. **City** and/or **County** Personnel (if impacted)

**Exhibit 11.2 Distribution/Notification of Plans Availability (Continued)**

**Clarity Task 5428: Functional Design**

(Public Hearing Plans) (use cell "Preliminary Plans")

Print two full and two half-size plans to take to the Public Hearing

Notify the following that the Roadway Design Functional Design Plan Set is available in OnBase and give file location

**Roadway Design**

Plan Quality & Standards Engineer  
Utilities Unit Head  
Utilities Coordinator

**District**

Construction Office  
District Construction Engineer  
Project Manager

**Impacted Divisions** (*if a major change was made to the PIH plans*)

(Example: a major change in the grade line - notify the Geotechnical Engr. in M&R)

**Traffic Engineering**

Division Engineer

**Local Assistance Division**

Rail Highway Liaison Manager  
(Verify that the X-secs. show the existing RR ROW & location of the rails)

**PDD**

Environmental Section Manager  
Scoping Engineer

**Project Scheduling and Program Management**

Program Coordinator

Optional Notifications/Distributions (*if applicable*)

Notify the following that the Plan Set is available in OnBase and give file location

**FHWA** (*if a major change was made to the PIH plans. Only on Interstate New and Reconstruction or on FHWA Risk Based Projects for Design*)

Division Administrator  
Engineering & Operations Team Leader  
Transportation Engineer

Transmit Plans

**City** (1 – ½ size plan)

**County** (1 – ½ size plan)

**Other**

**Note:** Notify **District**, **PDD Scoping Engineer** and **Rail Highway Liaison Manager** 5 weeks prior to Public Hearing as applicable

**Exhibit 11.2 Distribution/Notification of Plans Availability (Continued)**

**Clarity Task 5576: Design Detail Review**

Include Location map & typical section (use cell "Preliminary Plans")

Keep one half-size copy available in Design, stamp as "Design L.O.C. Plans"

Notify the following that the Design Details (L.O.C.) Plan Set is available in OnBase and give file location

**Highway Archaeologist**

**Aeronautics** (*if near an airport, See Chapter Ten, Section 3, of this manual*)

Division Head

**Roadway Design**

Plan Quality & Standards Engineer

Utilities Unit Head

Utilities Coordinator

ITS/Lighting Unit Head

**District**

Construction Office

District Construction Engineer

Project Manager

**Bridge**

Division Engineer

**Traffic Engineering**

Division Engineer

**Right-of-Way**

R.O.W. Design Engineer

**Materials & Research**

Division Engineer

Geotechnical Engineer

Pavement Design Engineer

Assistant Pavement Design Engineer

**Local Assistance** (*Verify that the X-secs. show the existing RR ROW & location of the rails*)

Rail Highway Liaison Manager

**Project Development**

Environmental Section Manager

Scoping Section Engineer

Roadside Development & Compliance Unit Manager

Technical Resources Unit Supervisor

**Construction Division**

Highway Construction Scheduling Manager

**PSS Scheduling & Program Management**

Project Scheduling/Program Coordinator

Optional Notifications/Distributions (*if applicable*)

Notify the following that the Plan Set is available in OnBase and give file location

**FHWA** (*Only on Interstate New and Reconstruction or on FHWA Risk Based Projects for Design*)

Division Administrator

Transmit Plans

**City** (1 – ½ size plan)

**County** (1 – ½ size plan)

**Other**

**Exhibit 11.2 Distribution/Notification of Plans Availability (Continued)**



**Clarity Task 5614: Design Plans to Utility Unit** (See Section 1.D of this Chapter)

Notify the following that the Roadway Design Utility Plan Set is available in OnBase and give file location

**Roadway Design**

Utilities Unit Head  
Utilities Coordinator

**PSS Scheduling & Program Management**

Project Scheduling/Program Coordinator

**NOTE:** If there are changes to the design after the **Plans Package Submittal (Clarity Task 5790)** to **PS&E** was sent out, a notification of change will be sent to the **Utility Unit Head** and to any impacted **Divisions (ROW, Wetlands/PDD - Environmental Section, District - DCE & PM, etc.)**. This note or e-mail should include the Project Name & Control Number, a brief description of the change, location, effect on the project, and the anticipated time updated plans will be available. If the change impacts the ROW and/or may impact the utilities, the designer will meet with the **Utility Coordinator** to determine if another plan set is required.

**Exhibit 11.2 Distribution/Notification of Plans Availability (Continued)**

#### 4.A Title Sheet (A)

**PDU** prepares, and updates, a Title (A) Sheet for use with the Preliminary Design (PIH) Plans (See Section 1.A of this chapter), the Design Detail Plans (See Section 1.C of this chapter), and for the Plans for Construction (See Section 1.E of this chapter). The roadway designer is responsible for providing the **Highway Design Technician** with the necessary information and its location in OnBase:

- Beginning and Ending Reference Posts & Stationing
- Recycling Note (from **M&R**, Clarity Phase 7: Plan Package)
- Traffic Data
- **FHWA** Oversight Stamp (if Risk Based Project, See Section 7 of this chapter)

#### 4.B The Typical Cross-Section Sheets (B)

Generic Typical Cross-Section (B) Sheets are required for the Preliminary Design Plans (See Section 1.A of this chapter). The Preliminary Design Plans B sheet(s) may be created using the preliminary pavement design thickness from **M&R** and the appropriate typical section for the project design standard, as developed from the Nebraska Minimum Design Standards (MDS) (Ref. 11.3) (<https://dot.nebraska.gov/media/1z1n5kmb/nac-428-rules-regs-nbcs.pdf>) and/or as shown in Chapter Six: The Typical Roadway Cross-Section. B Sheet details for subsequent design plan sets will be developed by **PDU** from information submitted by the roadway designer and/or **M&R**.

The typical sections of the through highway should be shown first, followed by subsequent typical sections in the order that they appear along the through roadway. Details (such as transitions, feathers, inlays, grading and/or surfacing under guardrail, etc.), will be included on the Plans for Construction B sheet(s) (See Section 1.E of this chapter). The cross-section view of the roadway should show the following:

- The profile grade point (unless it is located at the roadway centerline) at the finished grade elevation.
- Types, thickness, and widths of surfacing materials.
- Slopes and dimensions necessary to define the typical section. Slope hinge points will be defined on surfacing sections as well as grading sections.
- The location or station range of the road to which the typical section applies will be shown directly below the section.
- The notes pertinent to the specific typical section.
- A note referencing the applicable standard plans.
- The type of sealant to be used on concrete projects.
- The Lane Width, Shoulder Width, and either the Horizontal Clear Zone or the Fixed Obstacle Clearance will be dimensioned and labeled on the typical sheet (See EXHIBIT 11.3).

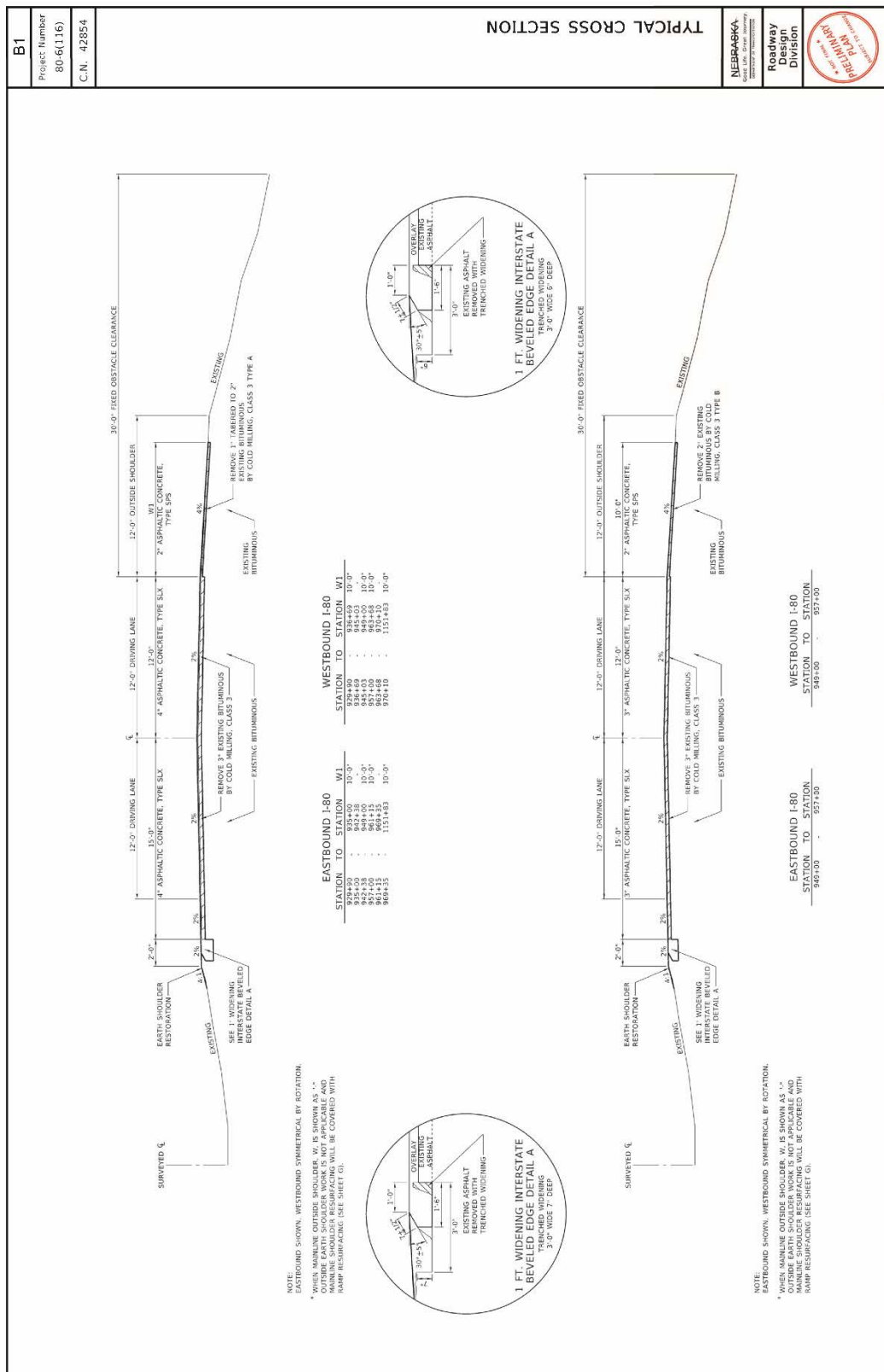


Exhibit 11.3 Typical Cross-Section (B) Sheet

#### **4.C Summary of Quantities Sheets (C)**

**PDU** creates tables for the Summary of Quantities (C) Sheet(s) from the project AASHTOWare quantities, after **PS&E** has reviewed the Design Plans. The C sheet shows separate summaries for each group of pay items included in the project. The types and grades of asphalt cement, emulsified asphalt, or asphaltic oil will also be shown. This sheet may also include:

- Compaction requirements (if there is no Soils and Materials Survey Information (D) Sheet)
- Tack Coating requirements
- Joint Repair Tables
- Other pertinent information necessary to fully summarize the items on the project

#### **4.D Soil and Materials Survey Information Sheets (D)**

Soil boring information, test data, and compaction requirements will be shown on the Soil and Materials Survey Information (D) Sheets, provided by **M&R**.

#### **4.E Environmental or Aerial Sheets (E)**

When Environmental or Aerial (E) Sheets (herein after called Environmental) are included in the plan set, they will cover the entire station range of the project. If wetlands are present on a project, the E sheets will show the delineated wetlands, impacted wetlands, sensitive areas, and mitigation sites.

The following scales will be used for Environmental sheets:

- 1" = 100' for rural and urban projects
- 1" = 50' for a short urban project
- 1" = 20' for a bridge project or an intersection project

The Begin Station for each sheet shall start at a major station (100+00, 105+00, 110+00, etc.). The stationing and scale of each sheet, as well as the order of sheets, usually match that of the Plan, Plan over Plan, or Plan and Profile Sheets (See Section 4.L of this chapter).

Environmental Sheets should show the following information:

- The stationed project centerlines
- Stationing ties for intersecting centerlines
- North Arrow
- Project Number
- Control Number
- Aerial Date
- Flight Information
- Limits of Construction (lines only)
- Proposed Edge of Pavement
- Existing culverts
- Sensitive & Do Not Disturb Areas
- Wetland Legend

#### **4.F Alignment and Control Point Data Sheets (F)**

Alignment and Control Point (F) Sheets are prepared by **PDU** and may contain three separate sets of information:

- Alignment design data, with stations and coordinates (X, Y, and azimuth)
- Control Point Data
  - Note on sheet – “Control Point tie information available on request”
- Benchmark information

#### **4.G General Information Sheets (G)**

General Information (G) Sheets may be used to reduce the amount of information shown on other plan sheets. Information normally placed on these sheets includes, but is not limited to:

- A legend depicting the cells used for topographic features
- Standard notes
- Culvert pipe legend (if required)
- Earthwork tabular notes
- Sketches of surfaced driveways and intersections (including quantities for each)
- Detour routes (but not temporary roads)
- Mailbox and mailbox turnout information
- Standard details, such as dikes or riprap for scour holes
- Standard notes for sensitive and restricted areas
- Rumble Strip Tabular
- Superelevation Information and additional asphalt quantities for correction
- Access crossing
- Special Ditch Chart
- Other (see Section 2.E)

#### **4.H Phasing Plan Sheets (H)**

Phasing Plan (H) Sheets show construction phasing, temporary construction, and the completed construction. Normally, the only construction note that should appear on the phasing plans would be a tabular build note for temporary surfacing, and geometrics when required. Phasing for drainage items is shown on the Drainage Structure Cross-Section sheets (See Section 4.R of this chapter).

#### 4.J Large Scale Plan Sheets (J)

Large Scale Plan (J) Sheets (50 or 20) are normally used for urban, expressway, or Interstate projects. J sheets may also be prepared for rural projects to show details of construction more clearly, such as roadway/intersection geometry, raised islands, grades, etc. The J sheets may consist of a combination of the following sheet sets, depending on the type and complexity of the project:

- Geometrics (combine with grades if space allows)
- Surfacing Elevations and Grades (See Section 4.J.1 of this chapter)
- Fencing
- Drainage
- Joints (combine with the geometrics if the longitudinal joints require geometrics)
- Construction (combine with removal if space allows)
- Removal
- Sidewalks and Curb Ramps

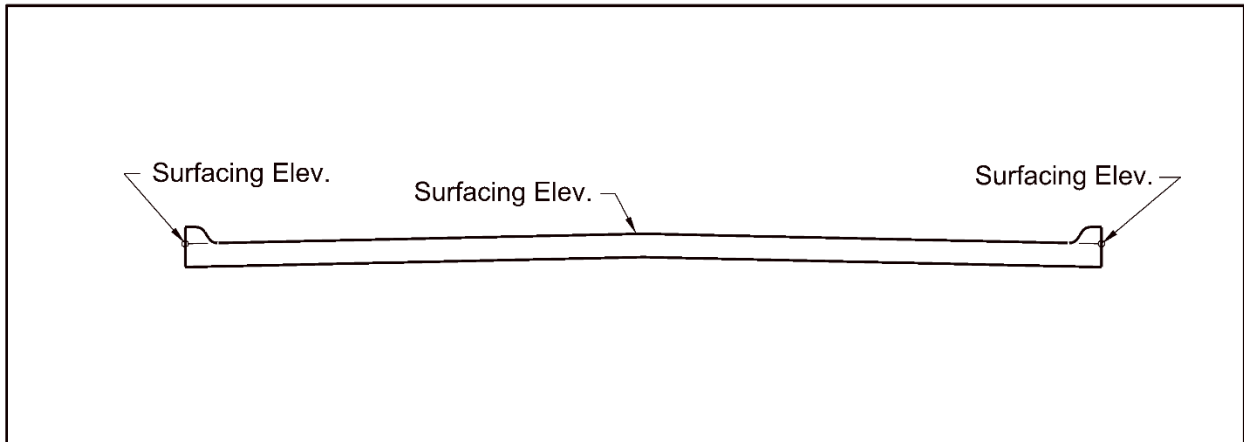
If the construction and removal notes are to be combined on one set of plans, the notes will be kept separate. The removal notes are placed on the upper half of the sheet and the construction notes are placed on the lower half of the sheet. For some less complex urban projects the drainage, construction, and removal notes may be combined into one set of plans. Information regarding existing conditions will be in all caps in the tabular notes.

##### 4.J.1 **Concrete Surfacing Elevations and Grades**

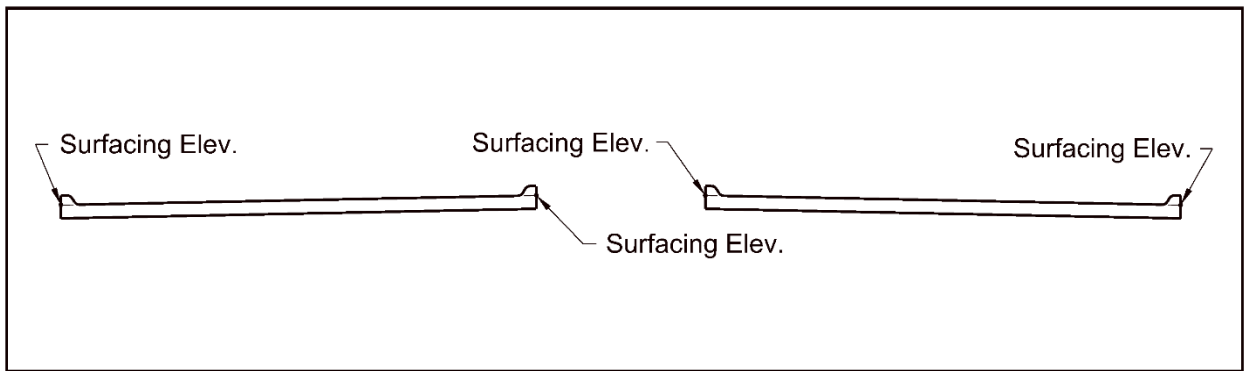
The roadway designer will provide concrete surfacing elevations for New and Reconstructed projects. The elevations should be provided at 25-foot intervals for the following locations:

- Municipal Undivided - Surfacing elevations should be shown at the centerline, at any breaks in the cross slope, and at the intersection of the back of curb and the projected pavement cross slope (See [EXHIBIT 11.4](#)).
- Municipal Divided - Surfacing elevations should be shown at locations where the back of curb and the projected pavement cross slope intersect and at any breaks in the cross slope (See [EXHIBIT 11.4](#)).
- Median Breaks at Intersections - Surfacing elevations should be shown at locations where the intersection of the pavement cross slope and the back of curb would normally be for the roadway section (Grade Line) (See [EXHIBIT 11.4](#)).
- Rural – Surfacing elevations should be shown at the profile grade point at 50-foot intervals on vertical curves and 100-foot intervals on tangent sections.

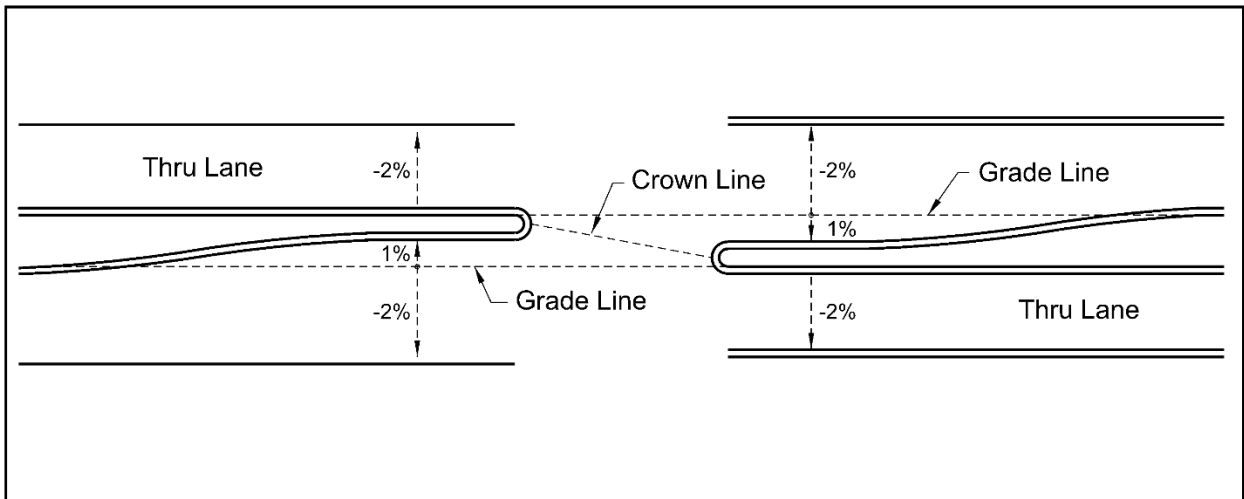
Whenever there is a deviation from the typical roadway cross-section the grade elevation should be shown. For example, when the gutterline is rolled in a flat profile section for drainage purposes the change in grade elevations will be indicated.



**Municipal Undivided**



**Municipal Divided**



**Intersections**

**Exhibit 11.4a Surfacing Elevations**

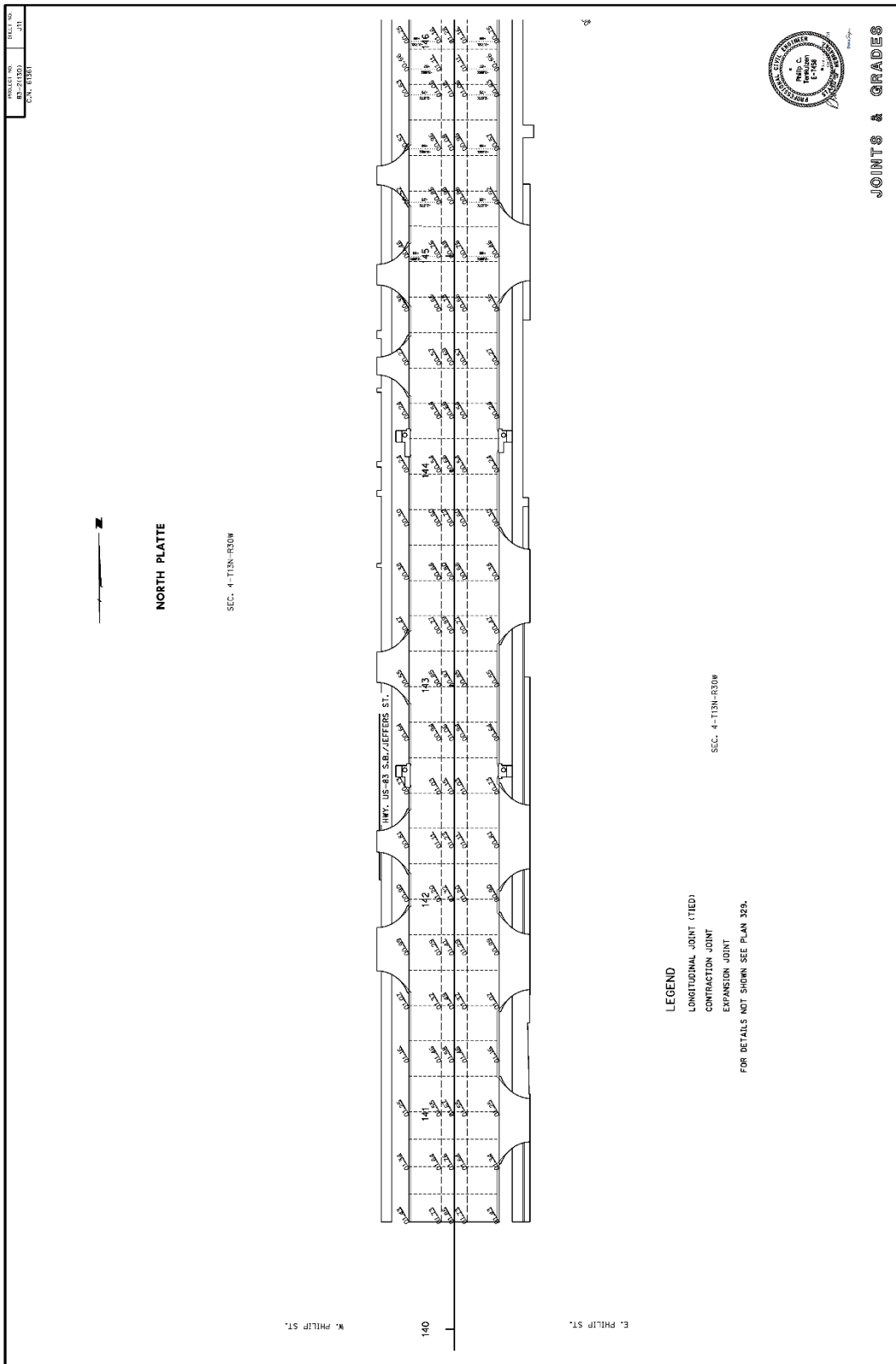


Exhibit 11.4b Grades

ROADWAY DESIGN DIVISION

COMPUTER: B0419M187

DATE: 21-01-2022 12:15

SCALE: 1/20



#### **4.K      Utilities Plan Sheets (K)**

When a project impacts utilities, requiring their relocation or rehabilitation, **Utility Companies/Consultants**, coordinating with the **Utilities Unit**, will provide **Roadway Design** with the required Utility Rehabilitation Plan (K) Sheets in a large-scale format (50 or 20 scale). For additional information see Section 1.D of this chapter.

#### **4.L      Plan, Plan over Plan, or Plan and Profile Sheets (L)**

(L) Sheets are presented based on the scope of the entire project. 3R projects are usually presented on Plan over Plan sheets, which are split sheets showing a plan view of the project on both the top and bottom half. The pavement strategy of these projects do not require an existing or proposed profile to be provided. New and Reconstructed projects are presented and Plan and Profile sheets, which are split sheets showing the plan view of the project on the top half of the sheet and the project profile below, including special ditches and special ditch tabular notes. 3R projects may also include Plan and Profile sheets if there is pavement replacement or a bridge replacement included in the project.

Individual construction notes on the (L) Sheets should be written vertically, right side up. The length of the note box should be uniform throughout the length of the project. The notations will be written so that they read from either the bottom or the right side of the sheet.

The Begin Station for each sheet shall start at a major station (100+00, 105+00, 110+00, etc.). The stationing and scale of each sheet, as well as the order of sheets, usually match that of the Environmental or Aerial Sheets (See Section 4.E of this chapter).

#### **4.M      Traffic Plan Sheets (M)**

**Traffic Engineering** will provide the roadway designer with the required Traffic Plan (M) Sheets, including the “Traffic Control Plan”, the “Temporary Pavement Marking Plan”, and the required traffic control devices (such as, signs, signals, pavement markings, delineators, traffic detector loops, etc.). **Traffic Engineering** will also provide the roadway designer with a listing of the standard plans required for the project (See Section 2.A of this chapter).

#### **4.N      Roadway Lighting Plan Sheets (N)**

When a project includes lighting, the **ITS/Lighting Unit** in **Roadway Design** is responsible for the Roadway Lighting (N) Plan Sheets. The **ITS/Lighting Unit** will also provide a list of standard plans required for the project (See Section 2.A of this chapter).

#### **4.O      Intelligent Transportation System (ITS) Project Plan Sheets (O)**

When a project includes the provision of new and/or impacts to existing ITS elements (e.g. traffic sensors, fiber optic cables, Interstate autogates, traffic cameras), the **ITS/Lighting Unit**, in coordination with the roadway designer, will provide **PDU** with the necessary information to create the ITS Project Plan (O) Sheets. ITS project plans will be presented on large-scale sheets (50 or 20 scale).

#### **4.P      SWPPP, Landscaping, and Erosion & Sediment Control Plan Sheets (P)**

**PDD RDC** may work with **PDU** in the creation of the SWPPP, Landscaping, and Erosion & Sediment Control (P) Plan Sheets (which includes Wetland Areas, Restricted Areas, tree plantings, flower bed arrangements, etc.). The SWPPP, Landscaping, and Erosion & Sediment Control plans (which includes Wetland Areas and Restricted Areas) will be presented on large-scale sheets (50 or 20).

#### **4.Q      Earthwork Data Sheets (Q)**

Earthwork Data (Q) Sheets consist of the computer-generated computations showing the cumulative project earthwork, station by station. Earthwork balance points should be shown for New and Reconstructed projects. For additional information see Chapter Seven: Earthwork of this manual.

#### 4.R Drainage Structure Cross-Section Sheets (R)

The roadway designer is responsible for producing the Drainage Cross-Section Sheets (R). Projects with culvert work or grading activities project-wide shall show a cross-section for all highway culverts, including existing highway culverts that are used in place. For storm sewer pipes, flumes, ditch drop pipes and driveway culvert pipes, a cross-section shall only be shown if it is new or if there is a proposed modification to an existing structure. These cross-sections shall be drawn along the flow line of the structure. Where cross-section slope lines and the drainage structure would extend beyond sheet limits, the slope line should be broken and indented, showing the break points by elevation and offset distance from the centerline (See [EXHIBIT 11.5](#)). The preferred scale for the cross-section is 1" = 10'. Scales of 1" = 5' or 1" = 20' may be used as circumstances dictate.

Cross-sections for highway culverts that are used in place shall show the existing ground line, the proposed cross-section of the road with annotations, the prelim note with the description of the existing structure, and a use in place note. The existing culvert shall not be shown.

Cross-sections for new or modified drainage structures shall show the proposed cross-section of the road with annotations, the construction notes, the hydraulic information (See Section 3.F of this chapter), and all drainage items (culvert pipes, box culverts, storm and sanitary sewers, curb inlets, manholes, flared-end-sections, headwalls, etc.). If an existing box culvert is being extended, the roadway designer should include a table listing the thickness of the existing culvert top, floor, and walls. The quantities within the construction notes will correspond to the items tabulated in the Summary of Quantities Sheets (See Section 4.C of this chapter) and in the construction and removal notes (See Sections 4.J and 4.L of this chapter), as shown in the plans.

Drainage Cross-Section (R) Sheets for skewed culverts, storm sewer, or other complex drainage structures may include a plan view of the culvert for information only. The plan view shall show a north arrow, the alignment stationing and the drainage structure shown in the cross section. If applicable, the drainage structures shall be labeled to match the Design Detail (J) Sheets (See Section 4.J of this chapter). The plan view does not need to be drawn to scale and shall be labeled "Not to Scale" in this case.

#### 4.S **Bridge Plans (S)**

**Bridge** provides the roadway designer with the Bridge Plans (S) for each project, as needed.

For uniformity and consistency, the bridge plans will consist of:

- Layout Sheet
- Geology and Pile Layout
- Substructure Details
- Superstructure Details
- Girder Layout
- Cross-Sections and Deck
- Approach Slabs
- Slope Protection

#### 4.T **Bridge Special Plans (T)**

**Bridge** provides the roadway designer with certain Special Bridge Plans (T) for each project, as needed, including but not limited to:

- Box Culverts
- Headwalls
- Non-standard Concrete Collars
- Pier Protection

#### 4.U **Roadway Special Plan Sheets (U)**

**PDU** prepares a Roadway Special Plans Sheet, which consists of guardrail special plans (See Section 2.C of this chapter), standard special plans (See Section 2.B of this chapter), retaining wall plans, and other special plans

#### 4.V **Other Plans as Needed (V)**

**PDU** may prepare (V) Plan Sheets for any plans/details which are not accommodated by the other plan sheet types.

#### 4.W **Right-Of-Way Plan Sheets (W)**

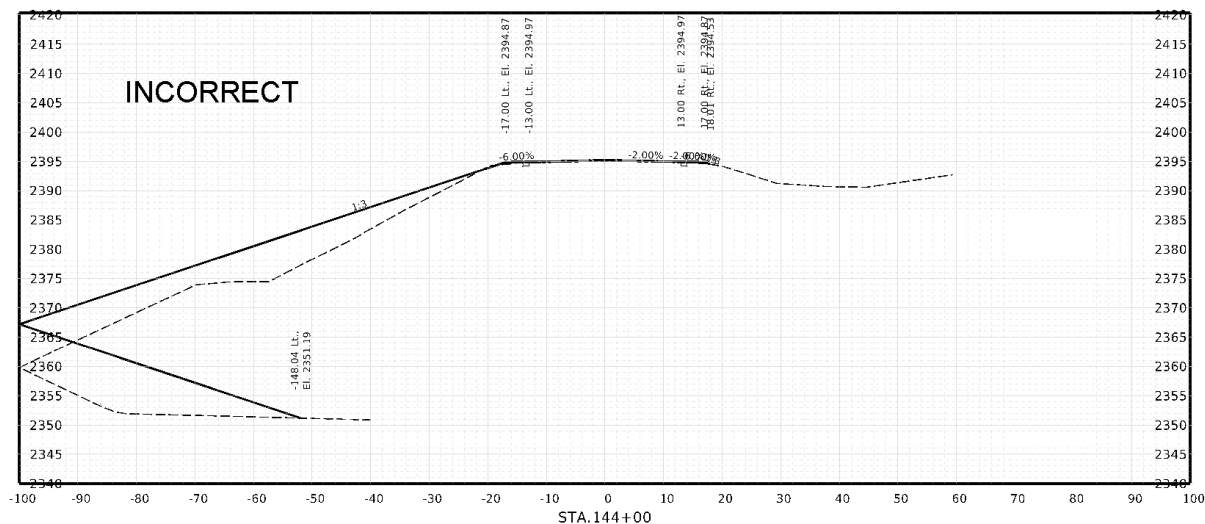
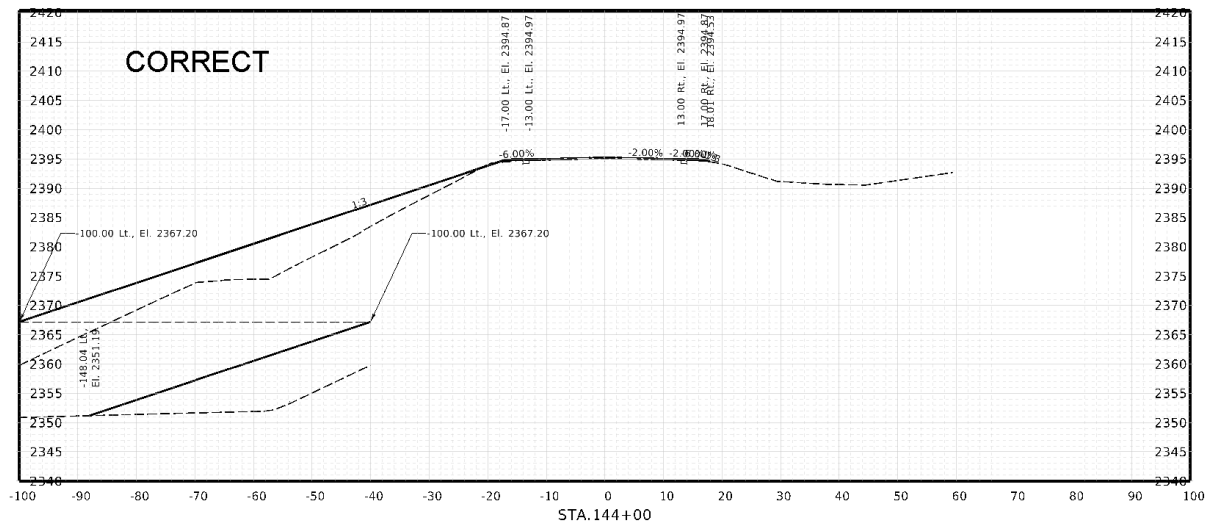
**Right-of-Way Design** prepares the Right-of-Way Plans (W) in stages (See Chapter Fifteen: Right-of-Way of this manual). The design plan set submitted to **PS&E** (See Section 1.E of this chapter) will include a set of right-of-way “PS&E Plans” (See Chapter Fifteen: Right-of-Way, Section 2.F, of this manual); the right-of-way plans title sheet will not be included.

**4.X Roadway Cross-Sections (X)**

The roadway designer is responsible for creating the Roadway Cross-Sections (X). Projects with grading activities shall show cross-sections at all locations along the project with grading activities, as well as additional locations as needed (See Chapter Seven: Earthwork, Section 3.D, of this manual). Cross-sections shall show the existing ground line, proposed pavement, proposed grading and annotation labels. Cross-sections should label existing right-of-way as well as proposed right-of-way, when applicable.

Cross-sections should not overlap each other. Where cross-section slope lines would extend beyond sheet limits, the slope line should be broken and indented, showing the break points by elevation and offset distance from the centerline (See EXHIBIT 11.5).

Roadway Cross-Section (X) sheets can be produced to read from the bottom or right side. The cross-sections are arranged by station with the lowest station at the bottom of the sheet and the highest station at the top. The scale of the cross-section shall be consistent across a single sheet.



**Exhibit 11.5 Roadway Cross-Section Break Lines**

## 5. PROFESSIONAL ENGINEER SEAL AND SIGNATURE

Projects which are to be let to bids by **NDOT** shall have the pages of the design plans sealed, signed (allowing the text on the seal to be read), and dated by a Professional Engineer in accordance with the Engineers and Architects Regulation Act (Neb. Revised Statutes Sections 81-3401 to 81-3455) ([The Nebraska Engineers and Architects Regulation Act | State of Nebraska Board of Engineers and Architects](#)). The license must be issued by the **Nebraska Board of Engineers and Architects** and shall be valid the year the project is let to contract. The engineer will sign the plan sheets before **PDU** compiles the pdf for turn-in to **PS&E**. The Engineer's Seal and Signature are typically placed on the lower right-hand corner of the sheet.

## 6. ADDENDUMS TO A PROJECT

After a set of plans has been advertised for letting, relatively minor items which impact the bids on a project (e.g. an incorrect quantity or a previously unknown or overlooked culvert pipe) will be handled with an addendum to the project. The addendum is a separate sheet, created by **Construction**, which is posted with the project plans detailing the change in quantities and, if required, including a detail of the item in question. If a detail is required it will be created by the responsible **Division/Section/Unit** (e.g. **Bridge, Roadway Design, ITS/Lighting**). Substantial changes to the project (e.g. a change in roadway grade impacting drainage and right-of-way) may result in the project being withdrawn from the letting. Changes to the plans typically will not be made at this time but will be handled as a plan revision after the project has been let to contract (See Section 7 of this chapter). If the addendum relates to a **Roadway Design** item, the roadway designer will coordinate the change with **Construction** and with any other **Divisions/Sections/Units** impacted by the change, for example a temporary easement may be required from **ROW**.

## 7. REVISIONS TO A PROJECT

Once the project plans have been executed, **they are legal documents** (executed means that both parties, **Contractor** and **NDOT**, have signed the contract). Revisions cannot be processed and dated until after the execution date; a plan revision may be prepared prior to the execution date but cannot be dated and returned to **Construction** until after the execution date.

All plan revisions after bid letting must include an environmental review statement. The roadway designer will coordinate all revision work with the **Environmental Project Manager** in the **Environmental Project Management Unit** of the **PDD Environmental Section** to determine whether the work in the plan revision will require additional environmental review. The **Environmental Project Manager** will provide the roadway designer with notification confirming (a) that additional environmental review will not be required or (b) that work on the revision may proceed with noted stipulations.

Only after environmental review and approval, the roadway designer will copy the CADD files to make the plan revisions (refer to the CADD Policy). The roadway designer will contact **PDU** and work with them to finish the revision. **PDU** will create a new pdf, including the revision, to be placed in ProjectWise for roadway designer/**Unit Head** review. Revisions on federally funded projects may require **FHWA** review and approval (See Section 7.A of this chapter). The pdf can be electronically signed by engineer.

The roadway designer will inform the **Highway Construction Scheduling Manager**, noting that the revised plans have been reviewed by the **Environmental Section**. After review and concurrence by the **Highway Construction Scheduling Manager** and the pdf is digitally signed by **Unit Head**, the revised CADD files are locked to prevent unauthorized changes to the contract plans.

For plan revisions prepared by **Roadway Design**, the roadway designer will send a notification (which can be an e-mail) detailing the proposed revision to the **Assistant Design Engineer (ADE)** and the **Unit Head**. The notification should include the following information:

- Project Name & Number
- Control Number
- Revision Number
- R.O.W. Tract Numbers affected
- A brief description of the changes
- An approximate completion date for the revision

If the **ADE** approves of the proposed revision the **Unit Head** will forward the notification to the following:

- **Environmental Section**
- **District Engineer (DE)**
- **District Construction Engineer (DCE)**
- **Construction Engineer**
- **District Project Manager**
- **Bridge** (if applicable)
- **Traffic Engineering**
- **ROW Design Engineer**
- **Utilities Unit ADE**
- **FHWA** (on federal oversight projects, See Section 7.A of this chapter)
- Other affected **Divisions/Sections/Units**

This notification alerts project stakeholders that a change is being made and allows for plan changes from different divisions to be consolidated into one plan revision.

The **Unit Head** and **ADE** will be informed of changes to the plans when those changes are made in the **District**. The **ADE** will decide whether a plan change should be handled with a change order or as a plan revision. Plan revisions *must* be signed and sealed by a Professional Engineer (P.E.). The **DE** or the **DCE** may assume the responsibility to seal and sign plan revisions processed in the **District** if the **Unit Head** and **ADE** are consulted about the design of the proposed revisions **before** they are finalized.

## 7.A Federal Oversight Projects

Under the terms of MAP-21 (<https://www.fhwa.dot.gov/map21/>) and the NDOT/FHWA Stewardship & Oversight Agreement (<https://dot.nebraska.gov/business-center/fhwa/>), **FHWA** will exercise oversight for plan revisions on federal-aid projects as follows:

1. Revisions for Risk Based Projects (RBPs) selected for **Construction** oversight (the roadway designer should check Clarity for the project status) which are on the National Highway System (NHS) shall have **FHWA** approval to proceed *before* the plan revisions are made (the **Unit Head** is responsible for informing the **Roadway Design Plan Quality & Standards Engineer** when **FHWA** approval has been received). The processed plan revisions must be approved by **NDOT** and must then be approved by **FHWA** as outlined in Section 7.A.1 of this chapter.
2. Revisions for RBPs selected for **Construction** oversight which are not on the NHS will be sent to the appropriate **FHWA Transportation Engineer** for review and comment but will be approved by **NDOT**.
3. All other federal-aid projects, regardless of location, will be approved by **NDOT**.

### 7.A.1 **FHWA Plan Revision Approval Process**

For RBPs selected for **Construction** oversight which are on the NHS, the plan sheets affected by the revision will be sent to **FHWA** as a pdf with the “DRAFT PLAN REVISION X” cell, in red, placed in the upper right corner of the draft plan revision pdf. A draft copy of the revision letter will be attached with the plan pdfs (See EXHIBIT 11.6) and **FHWA** will be informed that the revisions have been reviewed by the **Environmental Section** of **PDD**. Additional coordination may be required between **FHWA** and the **Environmental Section** of **PDD** as is necessary for the re-evaluation of the NEPA document. The plan sheets and document may be e-mailed to **FHWA** if possible; larger revisions will be sent to **FHWA** on a recordable data medium. After an **FHWA** approval e-mail has been received, full size plans and the approved plan revision letter will be attached with the plans to **Construction**. The letter is the same as the request letter sent to **FHWA**, except that a line is placed at the bottom citing **FHWA** approval, such as “FHWA concurred on May 24, 2021, through \_\_\_\_\_, FHWA Transportation Engineer” (or whoever at **FHWA** did the approval).



## 7.B Revision Procedures

The roadway designer may mark-up corrections on a pdf of the plans for the revised work and give the corrections to **PDU**. The approved revisions will be made. Two pdfs will be placed in the e-plans folder (a revised sheets only pdf and a pdf of the entire project).

After **Unit Head** review, the registered engineer responsible for the revision shall re-seal (or seal, if not the original engineer), sign, and date the revised sheet. Revised sheets that have a signature block will require a new signature with the following exceptions:

- The revised title sheet – the revision symbol and a note stating the original date that the **Specification Engineer** in **Construction** signed the plan are required for only the first revision (**Unit Head** signature is required for all revisions)
- The summary of quantities sheet – the responsible engineer's seal and signature is required but the **Specification Engineer's** signature is not required
- Deleted sheets are not signed by anyone

**PDU** will send an e-mail to the responsible engineer who will then contact **Construction**, including an electronic letter written to the **Highway Construction Scheduling Manager** (See [EXHIBIT 11.6](#)) noting which sheets have been revised, added, or deleted. The letter must explain each change to the plans resulting from the revision; the date on the revision letter will correspond to the date on the revised sheets. The designer will also e-mail the **Highway Project Manager** in **Construction** with a justification/reason for the revisions.

Date: January 11, 2021

To: Highway Construction Scheduling Manager, Construction Division

From: Roadway Design Unit Head

Subject: Plan Revision R3 for Project 80-9(832)  
Dated November 20, 2020  
Project Location: Greenwood to Mahoney  
C.N. 12450A

Attached are full-size revised sheets for the above mentioned project.

This plan revision is required for the following reasons:

1. Phasing changes for cross-over which ties into the Waverly to Greenwood project, 80- 9(842), CN 12469. Previous cross-over did not account for that project being let. The cross-over surfacing was revised from 10" concrete to 13" doweled concrete due to the extended time frame of use during the two projects.

The following plan sheets were revised: 1, 2, C1, & C2.

The following CN 12450A sheets were added: H19A, H30A, & 66A.

The following CN 12450A sheets were deleted: H19, H30, & 66.

Quantity Changes are listed below:

<u>Group</u>	<u>Item</u>	<u>Old Quantity</u>	<u>New Quantity</u>	<u>Differential</u>
3	Crushed Rock Surface Course	37,725.000	37,181.000	-544.000 SY
3	13" Doweled Concrete	434,563.000	436,602.000	+2,039.000 SY
3	10" Concrete Pavement	7,663.000	4,490.000	-3,176.000 SY
3	Foundation Course, 6"	437,465.000	439,504.000	+2,039.000 SY
4	18" Culvert Pipe Type 2, 3, 4, 5, 6, 7, or 8	31.000	631.000	+600.0000 LF

This revision has been reviewed by the Environmental Section of the Project Development Division.

FHWA concurred on December 30, 2020 through FHWA Transportation Engineer

### 7.B.1 Revised Sheet

Revisions to the project plans should be made in the original sheet file. The original information that is to be revised must be retained, **do not** eliminate an original item. The change will be crossed out, while remaining legible, and the revised information added.

A quantity or line of text which is to be revised will be shown with a single line through the text (~~text~~). The original text will not be erased or edited. The new text will be written in near proximity to the original text, along with the revision number (R1). This revision symbol will be used to point out each change on a revised sheet.

Revised sheets will have the revision symbols and revision dates in their upper right corners (the revision date shall correspond with the date on the letter to the **Highway Construction Scheduling Manager**, See Section 7.B of this chapter). The revision symbols and revision dates will be shown as follows:

(R<sub>1</sub>) 11 JUL 22

### 7.B.2 Added Sheet

Revisions which are so extensive as to preclude their being made on the original plan sheet will be made on a new added sheet. This sheet will be placed immediately after the original sheet and will be differentiated by the addition of a letter to the sheet number. For example, added sheet L43A would be placed immediately following original sheet L43, which will then be retained in the plan set as a deleted sheet.

On special plan sheets, the plan number will remain the same (e.g. 6C) but the sheet number will change.

The following designation will be placed on the added sheets:

(R<sub>1</sub>) ADDED SHEET 11 JUL 22

The revision date shall correspond with the date on the letter to the **Highway Construction Scheduling Manager**, See Section 7.B of this chapter.

### 7.B.3 Deleted Sheet

Sheets which are to be cancelled, voided, or deleted from the plans will remain in their location within the plan set and a large “X” will be placed across the sheet without covering the sheet number. The revision symbol, deleted sheet note, and date (corresponding with the date on the letter to the **Highway Construction Scheduling Manager**, See Section 7.B of this chapter), will be noted at the top right-hand corner of the sheet (See [EXHIBIT 11.7](#)).



DELETED SHEET 11 JUL 22

### 7.B.4 Quantity and/or Pay Item Changes

Quantity changes will be added to or subtracted from the quantity shown on the summary of quantities sheets. The revision symbol will be used to point out each change and the symbol and date (corresponding with the date on the letter to the **Highway Construction Scheduling Manager**, See Section 7.B of this chapter) will appear at the top right-hand corner of the summary of quantities sheets (See [EXHIBIT 11.10](#)).

Changes in quantities resulting from the revision will be detailed in the letter to the **Highway Construction Scheduling Manager** (See Section 7.B of this chapter). The funding source(s) of the pay items will also be specified (See Chapter Twelve: [Cost Estimating & Funding](#), Section 2, of this manual). When plan revisions add pay items which are not already in the plans or that create the need for a special provision, the special provision will be submitted as part of the letter to the **Highway Construction Scheduling Manager**, along with the revised plan sheets.

### 7.B.5 Detail Sheet

Deleted details should have a box drawn around them, an “X” drawn from corner to corner, and will be labeled (within the block) with the revision balloon (R1). (See [EXHIBIT 11.11](#)). There are times when this would not be the most appropriate method, such as when text for one sketch may overlap within the block area of adjoining sketches.

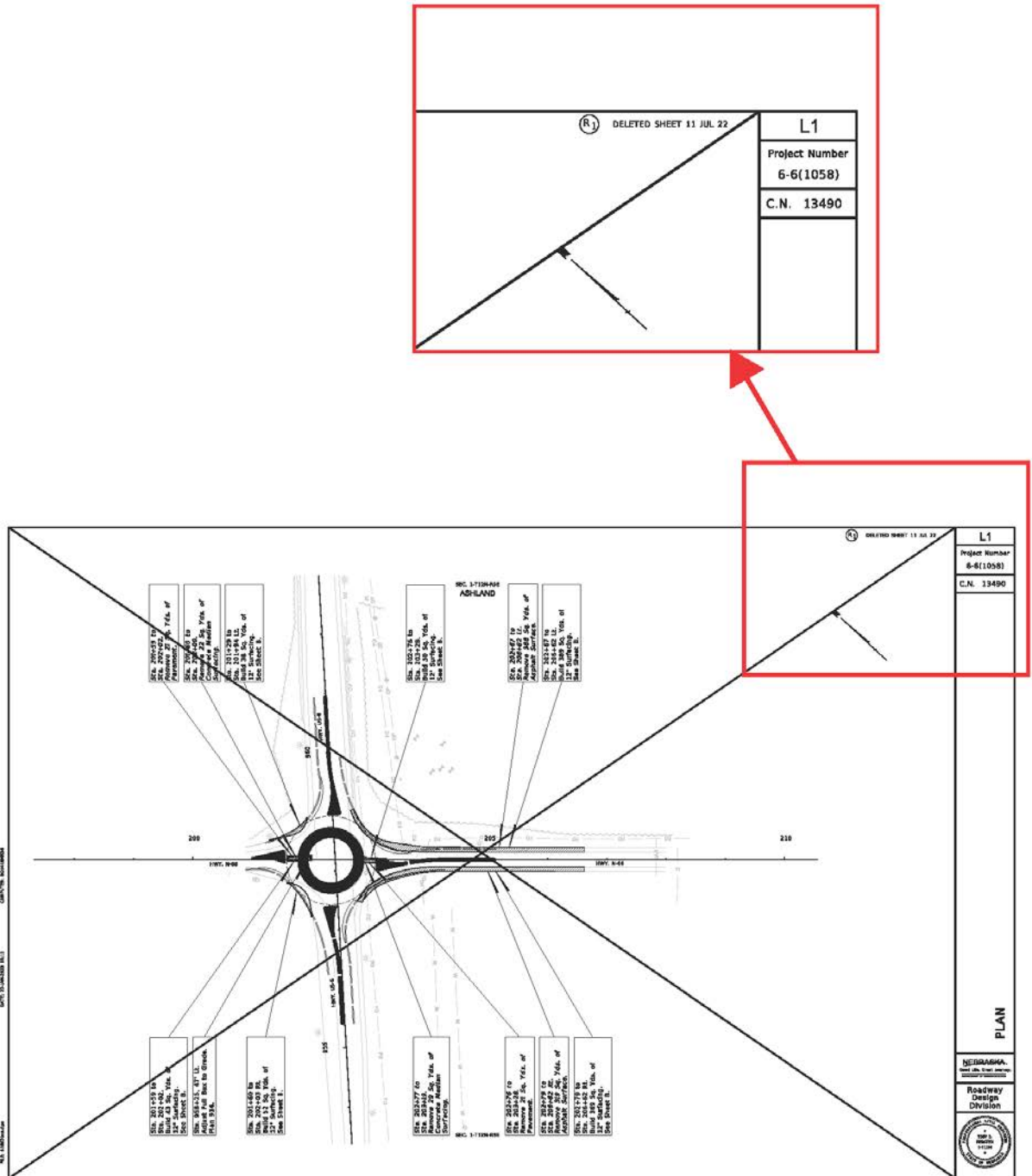


Exhibit 11.7 Deleted Sheet

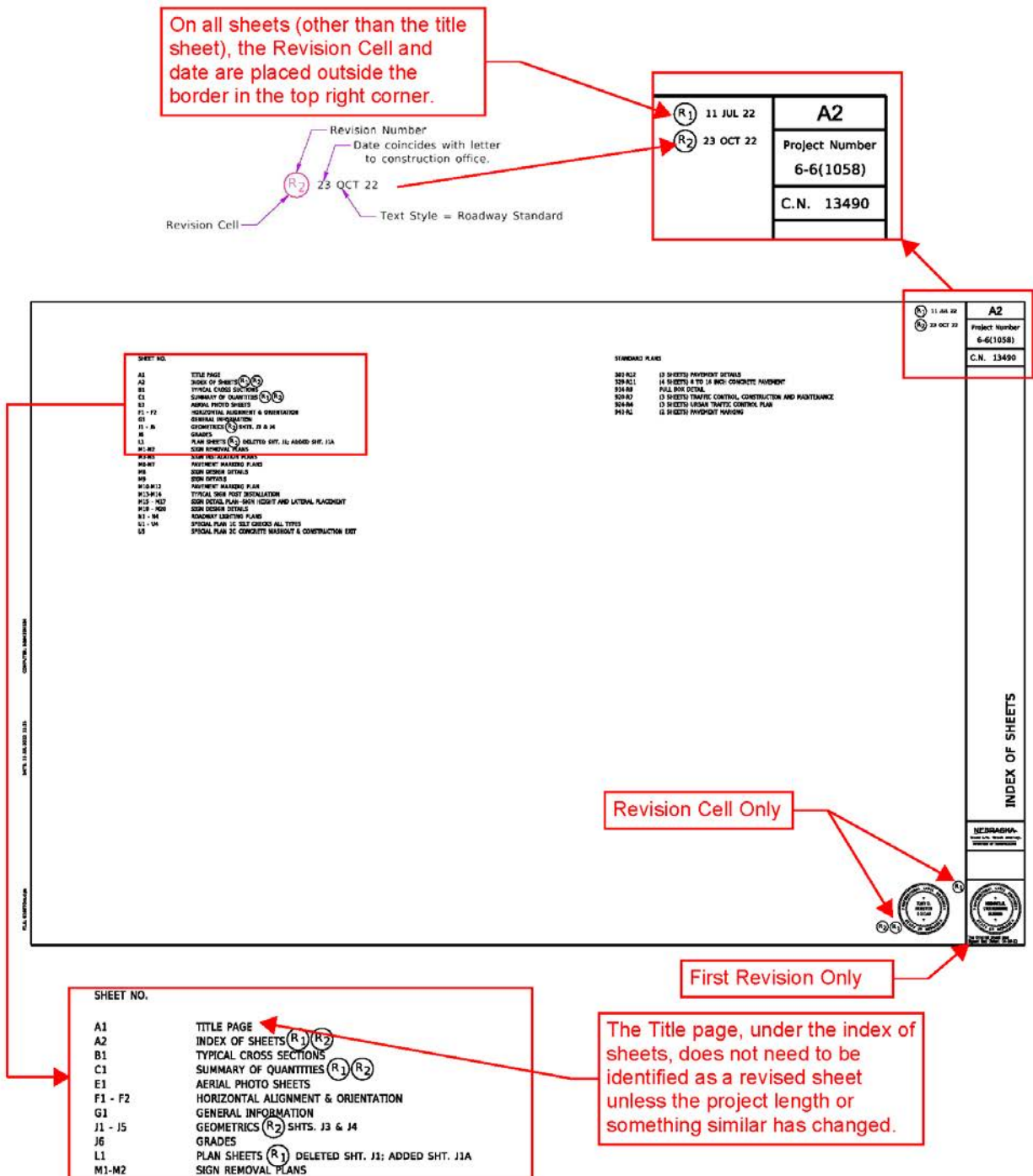


Exhibit 11.8 Revised Index Sheet

On the Title Sheet, the Revision Cell and date are placed in the border.

Revision Number

Date coincides with letter to construction office.

Revision Cell

23 OCT 22

Text Style = Roadway Standard

<b>A1</b>
Project Number MISC-6-6(1058)
C.N. 13490
▲ C.N.
▲ C.N.
■ C.N.
(R1) 11 JUL 22
(R2) 23 OCT 22

**STATE OF NEBRASKA**  
 DEPARTMENT OF TRANSPORTATION  
 PLANS FOR CONSTRUCTION  
**ASHLAND PILOT PROJECT**  
 SAUNDERS COUNTY

BEGIN PROJECT STA. 700+90 R.P. 97+50 HWY. N-66      END PROJECT STA. 960+95 R.P. 338+17 HWY. US-6

BEGIN PROJECT STA. 955+40 R.P. 937+81 HWY. US-6      END PROJECT STA. 205+11 R.P. 97+60 HWY. N-66

<b>A1</b>
Project Number MISC-6-6(1058)
C.N. 13490
▲ C.N.
▲ C.N.
■ C.N.

THE WORK ON THIS PROJECT CONSISTS OF GROUPS  
 1 - CONCRETE PAVEMENT 1 - GENERAL  
 2 - RETAINING & 10 - GENERAL

A GROUPS	1, 2, 3, 10	ARE INCLUDED
IN THE LETTERING OF	JUNE 26, 2022	
A GROUPS		ARE INCLUDED
IN THE LETTERING OF		
B GROUPS		ARE INCLUDED
IN THE LETTERING OF		

THE BEST EDITION OF THE NEBRASKA STANDARD SPECIFICATIONS AND ITS SPECIAL PROVISIONS APPLY TO THIS PROJECT.

DESIGN ESTIMATION	
TRAFFIC AVE. 154	
YEAR 2022	2022
ADT 3535	3840
DMU 451	451
P 1.5 %	2- 1.5 %

DESIGN ESTIMATION	
TRAFFIC AVE. 846	
YEAR 2022	2022
ADT 1188	1202
DMU 340	353
P 1.8 %	2- 1.8 %

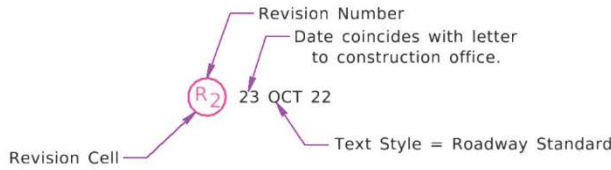
  

Revision Cell Only

<b>NEBRASKA</b> State Seal
(R1) (R2)
(R1) (R2)
(R1) (R2)

First Revision Only.

Exhibit 11.9 Revised Title Sheet



R1	11 JUL 22	C1
R2	23 OCT 22	
		Project Number
		C.N.

R1	23 JUL 22	C1
R2	23 OCT 22	
		Project Number
		C.N.

GROUP	ITEM	QUANTITY	UNITS	ITEM	QUANTITY	UNITS	ITEM	QUANTITY	UNITS
GRADING ITEMS GROUP 1	MOBILIZATION	1.000	LS	MOBILIZATION	1.000	LS	BARRETTAGE, TYPE II	1,200.000	BEAV
	REMOVE EXISTING	4.200	S/S	REMOVE GUARDRAIL	175.000	L/F	BARRETTAGE, TYPE III	1,750.000	BEAV
	REINFORCE EXISTING	1,213.000	S/F	BRIDGE APPROACH SECTIONS	4.000	CASH	TEMPORARY SIGN BAY	1,400.000	LA03
CULVERTS ITEMS GROUP 4	MOBILIZATION	1.000	LS	MOBILIZATION	1.000	LS	TEMPORARY SIGN BAY	1,400.000	LA03
	REMOVE EXISTING	4.200	S/S	BRIDGE APPROACH SECTIONS	4.000	CASH	TEMPORARY SIGN BAY	1,400.000	LA03
	REINFORCE EXISTING	1,213.000	S/F	BRIDGE APPROACH SECTIONS	4.000	CASH	TEMPORARY SIGN BAY	1,400.000	LA03
SEEDING ITEMS GROUP 5	MOBILIZATION	1.000	LS	MOBILIZATION	1.000	LS	TEMPORARY SIGN BAY	1,400.000	LA03
	REMOVE EXISTING	4.200	S/S	BRIDGE APPROACH SECTIONS	4.000	CASH	TEMPORARY SIGN BAY	1,400.000	LA03
	REINFORCE EXISTING	1,213.000	S/F	BRIDGE APPROACH SECTIONS	4.000	CASH	TEMPORARY SIGN BAY	1,400.000	LA03
BRIDGE AT STATION 213+70.00 ITEMS GROUP 6	MOBILIZATION	1.000	LS	MOBILIZATION	1.000	LS	TEMPORARY SIGN BAY	1,400.000	LA03
	REMOVE EXISTING	4.200	S/S	BRIDGE APPROACH SECTIONS	4.000	CASH	TEMPORARY SIGN BAY	1,400.000	LA03
	REINFORCE EXISTING	1,213.000	S/F	BRIDGE APPROACH SECTIONS	4.000	CASH	TEMPORARY SIGN BAY	1,400.000	LA03
GUARDRAIL ITEMS GROUP 7	MOBILIZATION	1.000	LS	MOBILIZATION	1.000	LS	TEMPORARY SIGN BAY	1,400.000	LA03
	REMOVE EXISTING	4.200	S/S	BRIDGE APPROACH SECTIONS	4.000	CASH	TEMPORARY SIGN BAY	1,400.000	LA03
	REINFORCE EXISTING	1,213.000	S/F	BRIDGE APPROACH SECTIONS	4.000	CASH	TEMPORARY SIGN BAY	1,400.000	LA03
BITUMINOUS ITEMS GROUP 9	MOBILIZATION	1.000	LS	MOBILIZATION	1.000	LS	TEMPORARY SIGN BAY	1,400.000	LA03
	REMOVE EXISTING	4.200	S/S	BRIDGE APPROACH SECTIONS	4.000	CASH	TEMPORARY SIGN BAY	1,400.000	LA03
	REINFORCE EXISTING	1,213.000	S/F	BRIDGE APPROACH SECTIONS	4.000	CASH	TEMPORARY SIGN BAY	1,400.000	LA03
GENERAL ITEMS GROUP 10	MOBILIZATION	1.000	LS	MOBILIZATION	1.000	LS	TEMPORARY SIGN BAY	1,400.000	LA03
	REMOVE EXISTING	4.200	S/S	BRIDGE APPROACH SECTIONS	4.000	CASH	TEMPORARY SIGN BAY	1,400.000	LA03
	REINFORCE EXISTING	1,213.000	S/F	BRIDGE APPROACH SECTIONS	4.000	CASH	TEMPORARY SIGN BAY	1,400.000	LA03

SUMMARY OF QUANTITIES

NEW ITEM	4,905,000	LB
SEAL OF RESPONSIBLE ENGINEER AND REVISION CELL	600,000	LF
REVISION CELL ONLY	175,000	S/F
FIRST REVISION ONLY	432,000	S/F

SEAL OF RESPONSIBLE ENGINEER AND REVISION CELL

REVISION CELL ONLY

FIRST REVISION ONLY

The Original Sheet was  
 Dated etc. Date: 04-28-22

Exhibit 11.10 Revised Summary Sheet



**QUANTITIES TABLE**

X	CONCRETE (CU. YDS.)	STEEL (LBS.)	X	CONCRETE (CU. YDS.)	STEEL (LBS.)
2'-0"	0.7	49	5'-0"	2.4	96
2'-6"	0.8	64	5'-6"	1.5	107
3'-0"	0.9	85	6'-0"	1.8	111
3'-6"	1.0	76	6'-6"	1.7	123
4'-0"	1.1	80	7'-0"	1.8	127
4'-6"	1.3	92	7'-6"	1.9	138

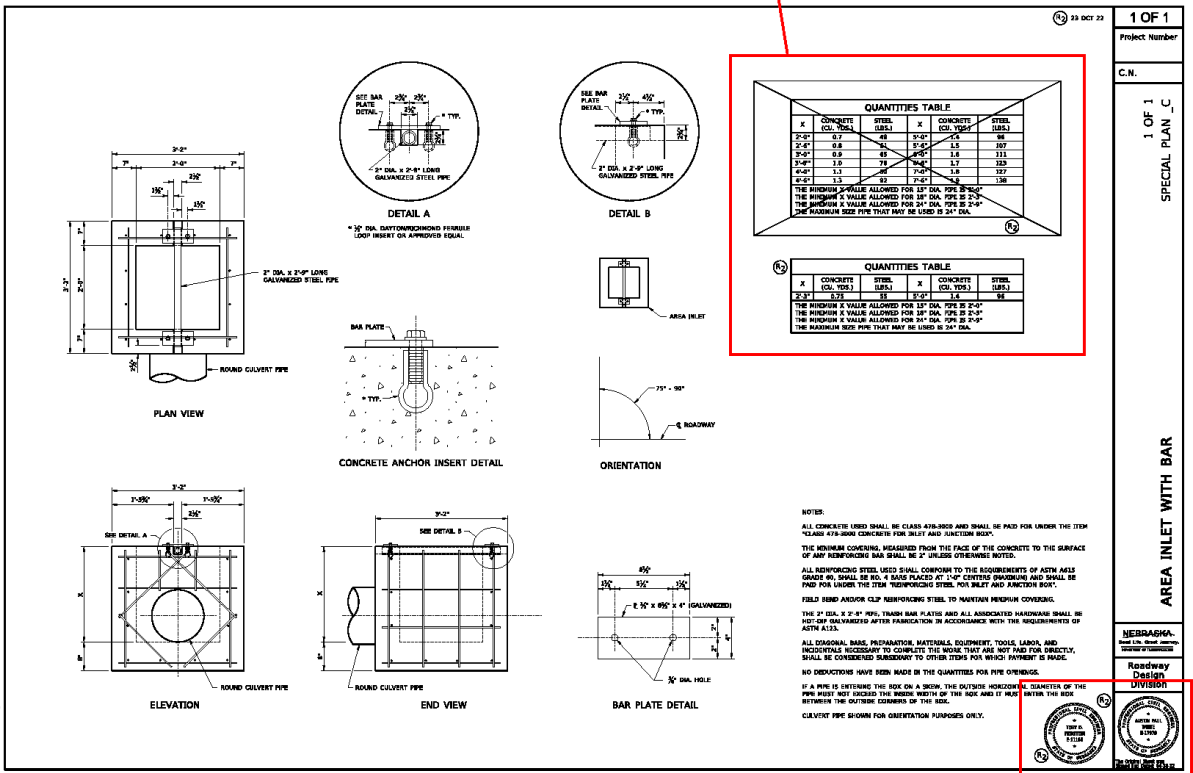
THE MINIMUM X VALUE ALLOWED FOR 15" DIA. PIPE IS 2'-0"  
 THE MINIMUM X VALUE ALLOWED FOR 18" DIA. PIPE IS 2'-3"  
 THE MINIMUM X VALUE ALLOWED FOR 24" DIA. PIPE IS 2'-9"  
 THE MAXIMUM SIZE PIPE THAT MAY BE USED IS 24" DIA.

**QUANTITIES TABLE**

X	CONCRETE (CU. YDS.)	STEEL (LBS.)	X	CONCRETE (CU. YDS.)	STEEL (LBS.)
2'-3"	0.75	55	5'-0"	1.4	96

THE MINIMUM X VALUE ALLOWED FOR 15" DIA. PIPE IS 2'-0"  
 THE MINIMUM X VALUE ALLOWED FOR 18" DIA. PIPE IS 2'-3"  
 THE MINIMUM X VALUE ALLOWED FOR 24" DIA. PIPE IS 2'-9"  
 THE MAXIMUM SIZE PIPE THAT MAY BE USED IS 24" DIA.



First Revision Only

Exhibit 11.11 Revised Detail Sheet

**7.C Revising a Project Which Has Been Rejected or Withdrawn from a Letting**

A project which has been rejected or withdrawn from a letting will be retained by the **PS&E Unit**.

If a project which has been rejected or withdrawn from a letting requires a revision, the project sheets will be revised in the same manner as if the project had been let, with four exceptions:

- Added sheets that are replacing a deleted sheet; in the upper right-hand corner of the sheet, where the revision is dated, note as follows: (R1) Revised Sheet DD MMM YY, (Day, Month, Year).
- Added sheets that are not replacing a deleted sheet: in the upper right-hand corner of the sheet, where the revision is dated, note as follows: (R1) Added Sheet DD MMM YY, (Day, Month, Year).
- Deleted sheets will be pulled from the plan set and will not be printed with the project.
- The revised title sheet and summary of quantities sheet(s) **will** be re-signed and dated by the **Specifications Engineer**, using the date provided by **Construction**.

	<b>PROJECT HAS BEEN AWARDED &amp; LET TO CONTRACT:</b>	<b>PROJECT HAS BEEN REJECTED OR WITHDRAWN FROM A LETTING:</b>
<b>Revised Sheets will read:</b>	(R1) DD MMM YY	(R1) DD MMM YY
<b>Added Sheets will read:</b>	(R1) Added Sheet DD MMM YY	(R1) Revised Sheet DD MMM YY
<b>Deleted Sheets will read:</b>	(R1) Deleted Sheet DD MMM YY	Will not be included with the project

**7.C.1 Title Sheet (Project Has Been Rejected or Withdrawn from a Letting)**

**PDU** is responsible for revising the title sheet for a project which has been rejected or withdrawn from a letting. A project which has been rejected or withdrawn from a letting will have one of these notations by the group block; these comments will not be identified with a revision symbol:

- No bids received
- Withdrawn
- Rejected

**8. REFERENCES**

- 11.1 Nebraska Department of Transportation, Design Process Outline (DPO), Current Edition (<https://dot.nebraska.gov/business-center/design-consultant/>)
- 11.2 Nebraska Department of Transportation, Standard/Special Plans Book (Standard Plans), Current Edition. (<https://dot.nebraska.gov/business-center/design-consultant/stand-spec-manual/>)
- 11.3 Board of Public Roads Classifications and Standards, Nebraska Minimum Design Standards (MDS), Current Edition. (<https://dot.nebraska.gov/media/1z1n5kmb/nac-428-rules-regs-nbcs.pdf>)



Chapter Twelve presents guidance for the design of New, Reconstructed and 3R projects; additional design guidance for 3R projects is provided in Chapter Seventeen.

# Chapter Twelve

## Cost Estimating & Funding

Cost estimating is an integral part of a roadway project. The roadway designer is responsible for providing the project quantity computations to the **Cost Estimating Unit** of the **Construction Division (Cost Estimating)** for their use in the production of accurate, reliable, and up-to-date cost estimates.

### 1. USES OF COST ESTIMATES

The degree of detail and accuracy required for each estimate increases throughout the design process. Estimates, therefore, vary from general approximations at the early stages of a project to very detailed cost estimates at the bid letting stage. Cost estimates are used for a variety of purposes, including:

- Planning, allocation, and funding (See Section 1.A of this chapter)
  - Distribution of funds to the **Districts**
  - Program decisions (State and local)
- Design alternative comparisons (See Section 1.B of this chapter)
- Bid comparison and analysis (See Section 1.C of this chapter)
- Agreements (See Section 1.D of this chapter)
- Railroad protective liability insurance (See Section 1.E of this chapter)
- NEPA (See Section 1.F of this chapter)
- Public meetings (See Section 1.G of this chapter)

#### 1.A Planning, Allocation, and Funding

Estimated project costs, inflated to account for costs in the year of construction, are used in determining the distribution of funds to the **Districts** and in developing State and local programs.

Estimated project costs may be supplied to **City** and/or **County** governments (with **Assistant Design Engineer (ADE)** approval) with the understanding that the information contained in the estimate is to remain confidential. Cost estimates are used by the **City** and **County** governments to plan and program their roadway improvements. **Cities** and **Counties** may also provide matching funds or participate in the **Nebraska Department of Transportation (NDOT)** projects (See Section 2 of this chapter).

### 1.B Design Alternative Comparisons

Designers in the **Roadway Design Division (Roadway Design)** may use cost estimates to compare design strategy alternatives. **Cost Estimating** can provide scratch cost estimates for these comparisons.

### 1.C Bid Comparison and Analysis

Advance planning with reliable cost estimates and updates is important for the timely letting and construction of roadway projects. Cost estimates are also used to compare and review bids.

### 1.D Agreements

Cost estimates are required for the financial portion of agreements regarding municipal utility relocation, participation by other agencies in the project, etc.

### 1.E Railroad Protective Liability Insurance (% of Work Near Railroad)

The **Construction Division** must provide the contractor with the percentage of work, by cost, within 50 feet of the centerline of the nearest railroad track on railroad right-of-way and the percentage of work within the railroad right-of-way that is further than 50 feet from the centerline of the nearest railroad track. The contractor needs this information to obtain railroad protective liability insurance. The roadway designer will calculate these percentages for the PS&E package (Clarity Task 5705 of the Design Process Outline (DPO), Ref. 12.2, <https://dot.nebraska.gov/business-center/design-consultant/>) using the following equations:

% of work on RR ROW within 50 feet of the centerline of the nearest track (Group \_) = [(The cost of Group \_ on RR ROW within 50 feet of the centerline of the nearest track) ÷ (The cost of Group \_ total)] x 100%.

% of work on RR ROW outside of 50 feet of the centerline of the nearest track (Group \_) = [(The cost of Group \_ on RR ROW beyond 50 feet of the centerline of the nearest track) ÷ (The cost of Group \_ total)] x 100%.

**Cost Estimating** can assist the roadway designer in calculating costs.

### 1.F NEPA

The amount of Federal funding, based on the cost estimate, is one threshold in determining the need and level of NEPA documentation for a project.

### 1.G Public Meetings

The cost estimate is used to both to inform and solicit feedback about the project at public meetings.

## 2. FUNDING AND COST SHARING

Funding for projects may come from a variety of sources (e.g. Federal, other State Agencies, Municipal).

### 2.A Federal Funding Programs

As stated in the Nebraska Revised Statutes, Chapter 39, Section 1365.02 “The Department of Roads shall apply for and make maximum use of available federal funding, including discretionary funding, on all highway construction projects which are eligible for assistance.” Federal funding available to **NDOT** includes, but is not limited to, the following programs.

#### 2.A.1 National Highway Performance Program (NHPP)

(<https://www.fhwa.dot.gov/bipartisan-infrastructure-law/nhpp.cfm>)

The NHPP provides funding for the operational performance and condition of the National Highway System (NHS), and for the construction of new facilities on the NHS. Funding is provided as a lump sum for each state, which is then divided among apportioned programs including a 2% set-aside for planning and research. The NHPP also ensures that federal-aid funds for highway construction are used to meet State established targets.

#### 2.A.2 Surface Transportation Block Grant Program (STBG)

(<https://www.fhwa.dot.gov/bipartisan-infrastructure-law/stbg.cfm>)

The STBG is a funding program that includes public roads (including the NHS) which *are not* functionally classified as minor rural collectors, local roads, or streets. It includes some collector routes that were not previously on the federal-aid system. In addition to being a funding source for these routes, the program specifies some set-aside funds for obstacle elimination projects and for transportation alternatives.

#### 2.A.3 Highway Safety Improvement Program (HSIP)

(<https://safety.fhwa.dot.gov/hsip/about.cfm>)

The HSIP utilizes a data driven approach for improving highway safety. The purpose of HSIP funding is the reduction of traffic fatalities and serious injuries on all public roads. HSIP funds are provided to the States as a lump sum which is then divided among apportioned programs, including Safety Improvement Projects (See Chapter One: Roadway Design Standards, Section 6.D, of this manual).

#### 2.A.4 Rail Highway Crossings (RRZ)

(<https://www.fhwa.dot.gov/fastact/factsheets/railwayhwycrossingsfst.cfm>)

The RRZ program provides funds for the elimination of railway-highway crossings on all public roads. They are usually matched with State Train Mile Tax (TMT) funds and **NDOT** only uses the funds to build new viaducts.

## 2.B Statewide Transportation Improvement Program (STIP) (<https://dot.nebraska.gov/projects/publications/stip/>)

A STIP is a key document in the Federal transportation planning and programming process. States are required to develop STIPs covering at least four years of federally-funded surface transportation projects in consultation with **Metropolitan Planning Organizations' (MPOs)**, Tribal governments, and local governments in nonmetropolitan areas, and with the participation of the public and interested parties. Projects contained in the STIP must be consistent with the statewide transportation plan and, when applicable, **MPO** transportation plans. The STIP includes the projects and project phases in approved **MPOs** Transportation Improvement Programs (TIPs) by reference. The **Program Management Division** develops the STIP and must demonstrate fiscal constraint, ensuring that there are sufficient revenue sources available to construct the listing of projects contained in the STIP. The STIP can be amended throughout the fiscal year when projects need to be added, removed, cost estimates updated, or change substantially in scope while still demonstrating fiscal constraint of the STIP.

Estimate updates trigger the majority of STIP amendments and, when in **MPO** areas, potentially the transportation plan. **NDOT** is required to submit an amendment any time there is a change in federal funds that exceeds 20% or \$2 million, whichever is greater. The **Federal Highway Administration (FHWA)** and the **Federal Transit Administration (FTA)** must approve the amendments and this approval process may take up to two months. For this reason, it is important to notify the **ADE** and/or **Program Management Division** when the project estimate changes significantly. This is especially critical as the project nears letting because the project cannot be advertised for letting until it is listed correctly in the STIP.

## 2.C Federal Funding - Participating

Many projects use multiple types of federal funding. For example, surface transportation funds may be used for the roadway portion of a project while bridge replacement and rehabilitation funds may be used for the structures. Project costs for participating projects must be itemized by funding types (See Section 2.G of this chapter).

### 2.C.1 Salvaging Items

The determination to salvage an item should be made prior to or on the plan-in-hand. If the **District** or another **Division** (e.g. **Materials and Research**) request that an item be salvaged, the roadway designer will note this on the plans and in the **PS&E** package to inform the contractor of the item(s) disposition. The roadway designer will quantify and provide a listing of the salvage items to **Cost Estimating** who will estimate a salvage value for the item(s) so that either **NDOT** (on delegated projects) or **FHWA** (on a Risk Based Project (RBP)) can determine if reinvestment back to the Federal-aid (FA) program is required. The value of salvaged items greater than \$5000 total for a FA project would need to be documented and reinvested back to the FA program. A note will be placed in the contract (PS&E) documents that items to be salvaged need to be stored on the project site for removal by **NDOT**. Examples of salvaged items include:

- Guardrail
- Delineators
- Culverts
- Millings
- Crushed concrete



## **2.D Federal Funding – Nonparticipating Items**

A project using federal funding may include nonparticipating items. For example, a new and reconstructed project on the National Highway System may include federal funding while an overlay of a State Spur which is a part of the same project involves state funds only. The reason for work being nonparticipating will be documented in the project file. The nonparticipating pay items, including their stationing, will be indicated as such on the quantity sheet in the computation file (See Section 2.G of this chapter).

## **2.E State of Nebraska Funding**

The **State of Nebraska** may fund roadway projects from a variety of state agency funding sources (e.g. **Game and Parks**).

## **2.F Participation by Others**

Some roadway projects may be joint ventures between **NDOT** and local government agencies (e.g. **City** or **County**) or other **States**. When other governmental agencies are sharing the cost of the improvement these costs should be split out in the cost estimate (See Section 2.G of this Chapter). However, if the agreement with the other governmental entity indicates that their participation is to be a lump sum amount, it is not necessary to break out or split quantities on the segments in which they are participating. Cost sharing guidelines are outlined in NDOT Operating Instruction 60-11, “Municipal Cost Sharing” (Appendix B, “Selected NDOT Operating Instructions”). Guidelines for agreements are found in NDOT Operating Instruction 45-5, “Agreements” (Appendix B, “Selected NDOT Operating Instructions”).

### **2.F.1 Utilities**

If utilities need to be adjusted or relocated due to a roadway project, the utility owner will complete the relocation of the facility unless otherwise specified. **NDOT** will pay the utility owner directly for the eligible non-betterment expenditures. If utility work results in a betterment of the facility, the utility owner will be responsible for those costs. See Section 7.C of this chapter, Chapter Ten: Miscellaneous Design Issues, Section 12, and NDOT Operating Instruction 45-1, “Utility Rehabilitation Negotiations” (Appendix B, “Selected NDOT Operating Instructions”) for further information.

### **2.F.2 Railroad**

Railroad owners will perform the necessary work associated with their property and will be reimbursed by **NDOT**. See Sections 1.E and 7.D of this chapter; Chapter Ten: Miscellaneous Design Issues, Section 1; and NDOT Operating Instruction 45-2, “Utility and Railroad Payments” (Appendix B, “Selected NDOT Operating Instructions”) for further discussion.

## **2.G Funding Splits Defined by Stations**

There are times when other governmental agencies share the cost of only a segment of a project (for example a project on the NHS, with Federal participation, which includes a State spur built with State funds only or a project which includes both rural and municipal segments). The quantities for that segment will be split out and the limits of the segment will be identified by station. For example, if a project includes municipal cost sharing the quantities for that portion of the project which lies within the corporate limits, as identified by project stationing, will be tabulated separately from the remainder of the project; the pay items and quantities within these limits will be separated out on individual computation sheets for each funding type. Funding splits will not be shown on the project plan sheets.

When a plan revision results in a change in project quantities, the funding source(s) of the affected pay items will be identified in the revision letter to the **Construction Engineer** (See Chapter Eleven: Highway Plans Assembly, Section 7.B.4, of this manual). Questions regarding funding split(s) on a project should be directed to **Cost Estimating**.

For additional information, see the NDOT Operating Instruction 60-11, "Municipal Cost Sharing" (Appendix B, "Selected NDOT Operating Instructions").

### **2.G.1 Lump Sum Funding Splits**

If another entity is contributing funds to a project based on a lump sum agreement, quantities do not have to be split out (unless the lump sum dollar amount is to be determined based on the quantities).

## **3. SOURCES OF PROJECT INFORMATION**

### **3.A Integrated Highway Inventory System**

The "Integrated Highway Inventory System", found in the CICS1 program on the computer mainframe, provides on-line project facts and funding information. To enter the "Integrated Highway Inventory System":

1. Click on the "Mainframe Sessions" icon.
2. Enter CICS1 by entering C1 and your DR# and password.
3. Select 2 – "Dept. of Transportation".
4. Select 4 – "Integrated Highway Inventory System".

The roadway designer will notify the **Program Management Division (Program Management)** if discrepancies are found between the information listed in the inventory and the information presented on other project forms, such as NDOT Form 73, "Highway Improvement Programming Request".

### **3.B Highway Improvement Programming Request (NDOT Form 73)**

NDOT Form 73, the "Highway Improvement Programming Request Form", should be reviewed by the roadway designer to obtain information about the project. Normally this form is initiated by the **District**.

## 4. SCHEDULE OF ESTIMATES IN ACTIVITY SEQUENCE

### 4.A General

Cost estimating activities must be coordinated with the participating parties (**Project Development Division (PDD)**, **Roadway Design**, **Bridge Division (Bridge)**, **Right-of-Way (ROW)**, **Roadway Design Utilities Unit (Utilities)**, **Strategic Planning**, **Local Assistance**, **Agreements**, etc.). The originator of the change will notify the **Divisions/Sections/Units** involved in the project of altered conditions, scope changes, or new requirements related to the project. EXHIBIT 12.1 summarizes the cost estimate schedule, including the timing and the responsible party.

The Initial Estimate (Status Code 05, "Program Phase") is developed by **Program Management**. At this early stage, the project costs are estimated on average per mile construction costs provided by the **Materials and Research Division (M&R)** together with estimated costs for preliminary engineering, construction engineering, contingencies, utility costs, right-of-way costs, and costs for bridge work, as required by the project (See Section 7 of this chapter). The roadway designer should verify that utility, right-of-way, bridge, and other items that are part of the project are included in the cost estimate from the earliest stages of design.

Cost estimates are required throughout the planning and design process and generally coincide with project milestone activities, such as Plan Details. Estimates should be updated at least annually up through Cost Update 3 (Status Code 45, "Plan Details Phase") and will also be updated whenever changes in the concept or in the scope of the project occur outside of the normal estimate activity schedule.

### 4.B Level of Detail

As part of the planning process, average costs per mile of construction are used to estimate the project cost. As the project's design develops in greater detail cost estimates begin to reflect the actual quantities of materials that are to be used.

Estimates should be as detailed as possible. Items necessary for the construction of the project will be included in each estimate, even though detailed quantities may not have been developed for some of the items. **Cost Estimating** will be informed of special conditions that would affect a bid estimate, such as tight work schedules, restricted working hours, night work, incentives/disincentives, etc.

Approximately 80% of a project's cost is usually found in 20% of the pay items. The roadway designer should allocate time accordingly, not spending an inordinate amount of time developing detailed quantities for minor items.

Status Code	Estimate Name	Time Frame	Level of Detail	Source of Estimate
<b>Prior to Roadway Design Division Involvement</b>				
05	Initial	Program Phase (5100)	Average per mile construction costs (from <b>M&amp;R</b> ) and estimated preliminary engineering, engineering construction and contingencies, utilities, right-of-way, and bridge costs.	<b>Program Management</b> , based on Initial NDOT Form 73 information provided by the <b>District</b>
10	Initial Estimate Update	Planning Phase (5200)	The Initial Estimate refined by the results of a review of the project location/corridor for any deficiencies, as well as inputs from other <b>Divisions</b> and the <b>District</b> .	<b>PDD</b> based on NDOT Form 73/ Planning Document
<b>Roadway Design Division Involvement</b>				
30	Cost Update 1 (Pre-Plan-in-Hand)	Design Phase (5300): After the preliminary plans are complete and just before the plan-in-hand (accompanies the plan-in-hand report). Updated annually up to Status Code 45 and if there is a change in project scope or concept.	Quantities from preliminary plans, special plans, etc. Includes preliminary bridge estimate and estimated preliminary engineering, engineering construction and contingencies, utilities, and right-of-way costs.	Roadway Designer and <b>Cost Estimating</b>
40	Cost Update 2 (Post-Plan-in-Hand) <i><b>Only required when a Public Hearing will be held</b></i>	Environ. Approval Phase (5400): After the plan-in-hand report is approved.	Project quantities from functional plans, updated special plans, approved pavement determination, utilities, right-of-way, etc.	Roadway Designer and <b>Cost Estimating</b>
45	Cost Update 3 (Post Roadway Design Details)	Plan Details Phase (5500): After design is complete and Design Plans have been distributed.	Project quantities from the Design Plans including right-of-way, bridge quantities, utilities, etc.	Roadway Designer and <b>Cost Estimating</b>
50	Plans, Specifications and Estimates (PS&E)	Plan Package Phase (5700): Just prior to bid letting.	Estimated plan quantities.	Roadway Designer and <b>Cost Estimating</b>
60	Awarded Bid	Bid Letting.	Actual contract cost from awarded bid.	<b>Contractor</b>

**Exhibit 12.1 Cost Estimate Submittals**

## 5. ESTIMATE REQUEST FORMS

The roadway designer will submit NDOT Form 342 (“Project Information Sheet”) and NDOT Form 343 (“Project Quantity Sheet”) to **Cost Estimating** for each cost estimate request.

### 5.A Project Information Sheet (NDOT Form 342)

Using NDOT Form 342, the roadway designer provides **Cost Estimating** with a summary of right-of-way needed, utility costs, preliminary engineering costs, data about the type of construction to be performed for the roadway surface and shoulders, and the type of bridge construction needed. This form also provides space for notes about traffic control and other elements of the project.

### 5.B Project Quantity Sheet (NDOT Form 343)

NDOT Form 343 lists standard pay items by standard item number and name. This form also lists the unit of measurement for each item. Quantities for each of the appropriate items should be calculated and listed on this sheet for each project. The quantities for some sections of this form (e.g. bridges, electrical, signing) may be supplied by other **Divisions/Sections/Units** and submitted to the roadway designer before it is sent to **Cost Estimating**.

## 6. COST ESTIMATE REQUEST PROCEDURES

Coordination, communication, and cooperation are essential elements in the cost estimating process. The roadway designer needs to coordinate with the parties involved with the project for the process to be most efficient and effective. If consultants are hired for design work the **Roadway Design Consultant Coordinator** assigned to the project is responsible for reviewing, communicating, and coordinating activities between the consultant and **NDOT**.

### 6.A Routing from the Roadway Designer

The roadway designer will obtain input from the **Divisions/Sections/Units** involved in the project to verify that the cost estimate request includes the items required to build the project. **Bridge**, the **Traffic Engineering Division (Traffic Engineering)**, **PDD**, **ROW**, **M&R**, etc. provide information to the roadway designer, who compiles the necessary information and then submits the cost estimate request to **Cost Estimating**.

The roadway designer should review the previous cost update request and cost estimate for needed changes before requesting a cost update. The previous cost estimate request form may be submitted to **Cost Estimating** with changes noted in red. The roadway designer should perform a careful review of the cost estimate request, verifying that the construction items needed to build the project are included.

### 6.B Timeliness

It is essential that the roadway designer submit cost estimate requests to **Cost Estimating** as early as possible. The time allocated to produce the cost estimate includes the time needed for **Roadway Design** review and for resulting corrections to be made to the cost estimate.

### 6.C Change in Project Scope or Concept

The roadway designer will request an updated cost estimate from **Cost Estimating** and will inform any other **Division/Section/Unit** which is involved in the project (e.g. **Environmental**, **ROW**) whenever a change is identified in the project scope, project concept, or when special conditions arise during design (e.g. a change in pavement determination, a change in bridge determination, removal of unsuitable material). A change in cost affects the project budget and schedule; the change in project scope shall be vetted by the appropriate **Divisions** (e.g. **Roadway Design Engineer**, **ROW**, **Project Development**, **Program Management**).

### 6.D Estimate Review

**Cost Estimating** routes the completed cost estimate to the roadway designer through the appropriate **ADE** and **Roadway Design Division Unit Head (Unit Head)**. The roadway designer and the **Unit Head** will review the cost estimate carefully for possible omissions, incorrect information, coding errors, deletions, etc. A comparison with the previous estimate can be a good check for mistakes. Cost estimating is an iterative process, intended to produce the best possible estimate.

## 7. CONTENTS OF COST ESTIMATES

Cost estimates basically consist of quantities and prices. Roadway designers provide the quantities and cost estimators provide the prices. Inaccurate or incomplete quantities and/or prices will produce cost estimates which are both inaccurate and inadequate. Project costs are subdivided into the following categories:

- Preliminary Engineering
- Right-of-Way
- Utilities
- Railroad Items
- Construction Costs
- Construction Engineering
- Contingencies
- Relinquishments (See Chapter Fifteen: Right-of-Way, Section 7.D, of this manual)

### 7.A Preliminary Engineering

Preliminary engineering costs are normally estimated as a percentage of the construction costs. Various factors may affect the actual costs of preliminary engineering, such as unusual site conditions for the project. The cost factors presented in EXHIBIT 12.2 are provided for the roadway designer's information, showing the percentages used by **Cost Estimating** in calculating the preliminary engineering costs for a project for Cost Update 1 (Status Code 30, "Design Phase") and Cost Update 2 (Status Code 40, "Environmental Approval Phase"), and Cost Update 3 (Status Code 45, "Plan Details Phase").

Chapter Section	Project Cost Category	Cost/Cost Factor
7.A	<b>Preliminary Engineering</b>	Calculated by <b>Cost Estimating</b>
7.A	Resurfacing Projects	0.5% of base Construction Costs
7.A	New and Reconstructed Projects	4.4% of base Construction Costs
7.A	Consultant Projects	8.0% of base Construction Costs
7.B	<b>Right-of-Way</b>	
7.B.1	Rural Land Values	<a href="https://digitalcommons.unl.edu/agecon_farmrealestate/">https://digitalcommons.unl.edu/agecon_farmrealestate/</a>
7.B.1	Urban Land Values	Contact <b>ROW Appraisal</b> for urban land values
7.B.2	Fencing	<a href="https://dot.nebraska.gov/media/kugj5cw5/fence-schedule.pdf">https://dot.nebraska.gov/media/kugj5cw5/fence-schedule.pdf</a>
7.B.3	Improvement Values	Contact <b>ROW Appraisal</b> for costs of damages to improvements
7.B.4	Relocation Assistance	Contact <b>ROW Relocation Unit</b> for relocation costs
7.B.5	Other R.O.W. Costs	40% of the cost of right-of-way land acquisition
7.C	<b>Utilities</b>	Calculated by <b>Cost Estimating</b> 2.9% of base Construction Costs
7.D	<b>Railroad</b>	Contact the <b>Highway Liaison Manager</b> in the <b>Local Assistance Division</b>
7.E	<b>Construction Engineering</b>	Calculated by <b>Cost Estimating</b> 12% of base Construction Costs if ≤ \$2 million 5% of base Construction Costs if > \$2 million
7.F	<b>Contingencies</b>	Calculated by <b>Cost Estimating</b> Contingency Costs may vary yearly
7.G.7	<b>Bridge</b> (to be included in <b>Construction Costs</b> )	Calculated by <b>Cost Estimating</b> or supplied by <b>Bridge</b> Based on Bridge Size and Type as supplied by the roadway designer (See <u>EXHIBIT 12.4</u> )

**Exhibit 12.2 Preliminary Cost Estimate Values/Cost Factors**

## 7.B Right-of-Way

The roadway designer will prepare a preliminary right-of-way cost estimate for inclusion with Cost Update 1 (Status Code 30, "Design Phase"), Cost Update 2 (Status Code 40, "Environmental Approval Phase"), and Cost Update 3 (Status Code 45, "Plan Details Phase"). The roadway designer should coordinate these cost estimates with **ROW Appraisal**, informing them of items which will affect the right-of-way cost estimate (such as clear tract, remove building, remove sign base) and requesting preliminary costs. The total right-of-way costs consist of five main elements:

1. Land Values (See Section 7.B.1 of this chapter)
2. Fences (See Section 7.B.2 of this chapter)
3. Improvements (See Section 7.B.3 of this chapter)
4. Relocation Assistance (See Section 7.B.4 of this chapter)
5. Other Right-of-Way Costs (See Section 7.B.5 of this chapter)

See the **NDOT** Right-of-Way Manual (<https://dot.nebraska.gov/media/0sopjmah/row-manual.pdf>) (Ref. 12.1) and Chapter Fifteen: Right-of-Way for additional information.

### 7.B.1 **Land Values**

Preliminary land value estimates for Cost Update 1 (Status Code 30, "Design Phase"), Cost Update 2 (Status Code 40, "Environmental Approval Phase"), and Cost Update 3 (Status Code 45, "Plan Details Phase") are based on the approximate number of acres of land to be acquired for right-of-way, as calculated by the roadway designer, multiplied by the average per acre cost of the type of land being acquired. **ROW Appraisal** develops actual area figures for the PS&E Estimate (Status Code 50, "Plan Package Phase").

#### 7.B.1.a **Rural**

The average values of farmland, classified by agricultural usage, are compiled annually by the University of Nebraska. This information may be viewed on the Internet at ([https://digitalcommons.unl.edu/agecon\\_farmrealestate/](https://digitalcommons.unl.edu/agecon_farmrealestate/)).

#### 7.B.1.b **Urban**

Land values in urban and suburban areas exhibit greater fluctuation than rural land values. Variations in land values for different land uses, and variations among those values for different cities, make it impossible to generalize cost figures for urban land. The **ROW Appraiser** should be consulted for non-agricultural land values.



### 7.B.2 Fences

The roadway designer will include fencing costs For Cost Update 1 (Status Code 30, “Design Phase”), Cost Update 2 (Status Code 40, “Environmental Approval Phase”), and Cost Update 3 (Status Code 45, “Plan Details Phase”) based on the average cost per mile for two sides of the roadway (See the Fencing Schedule at <https://dot.nebraska.gov/media/kugj5cw5/fence-schedule.pdf>). Fence costs are usually included in the **ROW** cost estimate for the PS&E Estimate (Status Code 50, “Plan Package Phase”). Privately owned fencing is generally not built as part of the project, the property owner is paid to replace the fence, but this amount will be included in the right-of-way cost estimate.

Interstate and freeway fencing will be included in the construction items. Certain additional fencing items may be included in the construction items (typically deer fence, wetland fencing, and pedestrian fencing). The roadway designer should check with **ROW Appraisal** to ascertain whether fencing has been included in the **ROW** estimate or if it is to be handled as a construction cost. If fencing is a construction item, the roadway designer shall include this fencing in the **Roadway Design** PS&E Estimate (Status Code 50, “Plan Package Phase”). See Chapter Ten: Miscellaneous Design Issues, Section 6, of this manual for further information.

### 7.B.3 Improvements

Improvements on property which may be acquired for right-of-way will be identified by size and type (homes, business structures, outbuildings, parking lots, parking spaces, center pivots, wells, etc.). **ROW Appraisal** maintains average values of improvements on property and should be consulted for costs for damages to an improvement or costs to purchase the improvement.

### 7.B.4 Relocation Assistance

Relocation costs are payments beyond the purchase cost. A person or business displaced by a construction project is eligible to participate in the Relocation Assistance Program; this program is designed to help pay the expenses for relocating residential occupants, businesses, farm/ranch buildings, and non-profit organizations if they are displaced as a result of a highway improvement. The roadway designer should contact the **ROW Relocation Unit** for relocation assistance costs.

### 7.B.5 Other Right-of-Way Costs

Other right-of-way costs, covering such items as appraisals and legal fees, are included in a project cost estimate as a factor of the sum of the previously described right-of-way costs (e.g. land, fences, improvements, and relocation assistance). Currently a factor of 40% (based on historical project costs) is used to estimate "Other Right-of-Way Costs".

### 7.C Utilities

**Cost Estimating** generally calculates preliminary utilities costs at 2.9% of construction costs. For projects with very minor utility work this figure may be lower while on projects with major utility work costs may be higher. The roadway designer will work with **Cost Estimating**, updating project costs as the scope and complexity of the utility work required for the project become apparent. For example, projects involving fiber optic cable or major overhead power lines will generally have greater utility costs, as will projects with major water line and/or sanitary sewer work. The roadway designer should coordinate the utilities impacts with **Utilities** during the preparation of the Plan-in-Hand Report. When actual utility costs are received (typically during Cost Update 3, Status Code 45, "Plan Details Phase") the roadway designer will verify that the 2.9% cost factor has been removed from the cost estimate.

If a contractor is to perform water main and/or sanitary sewer work as part of the state contract, these items will be included in the construction items estimate. If, however, this work is to be performed by someone else, the costs will be accounted for in the utilities cost estimate

See Section 2.F.1 of this chapter, Chapter Ten: Miscellaneous Design Issues, Section 12, and the Nebraska Dept. of Transportation Operating Instruction 60-11, "Municipal Cost Sharing" (Appendix B, "Selected NDOT Operating Instructions") for additional information.

### 7.D Railroad

The **Rail Unit** in the **Local Assistance Division** reviews the design plans and coordinates the project with the railroad companies. See Sections 1.E and 2.D.2 of this chapter; Chapter Ten: Miscellaneous Design Issues, Section 1 for further discussion on railroad-involved projects.

### 7.E Construction Engineering

The estimate for the construction engineering cost is based on a percentage of the base construction costs. At present, construction engineering is estimated by **Cost Estimating** to be 12% of the base construction cost when it is less than or equal to \$2 million and 5% of the base construction cost when it is over \$2 million.

### 7.F Contingencies

Contingencies are included in the cost estimate by **Cost Estimating** to account for possible cost overruns; contingency costs may vary yearly.

## 7.G Construction Items

Construction items are those items that will be let to contract. The roadway designer is responsible for providing accurate quantities and specifications so that **Cost Estimating** may produce accurate cost estimates for the roadway items required for the project. EXHIBIT 12.8, the “Cost Estimate Checklist”, lists many of the standard construction items used on a roadway project.

The roadway designer and the **Unit Head** should refer to this checklist, making sure that every item required for the construction of a roadway project is included in the cost estimate request and cost estimate. While the roadway designer is not responsible for calculating the quantities for every construction item (e.g. **M&R** calculates the final quantities for flexible pavement), the designer is responsible for verifying that the items required for the construction of the project are included in the various cost estimate updates and in the PS&E turn-in packet.

### 7.G.1 Mobilization

Several categories in EXHIBIT 12.8 have a mobilization item. Mobilization is the costs associated with startup activities such as movement of personnel, equipment, supplies, and other incidentals to the project site. Mobilization is a separate pay item for those categories where it is listed separately and is an incidental item subsidiary to other work when it is not listed separately. Mobilization costs are calculated by **Cost Estimating**.

### 7.G.2 Specifications and Special Provisions

The Standard Specifications for Highway Construction (*Spec Book*) (Ref. 12.3) (<https://dot.nebraska.gov/media/g4qp4y0d/2017-specbook.pdf>) defines the scope and control of work in a standard pay item, including an item description, listing of material requirements, equipment, hauling and distributing materials description, method of measurement, and basis of payment. An item which is not covered by, or that differs from, the *Spec Book* (Ref. 12.3) will require a special provision. Special provisions should be initiated during “Roadway Design Details” and finalized during the “Plan Package Design Modification” (See the *DPO* (Ref. 12.2), Clarity Task Codes 5508 and 5705).

### 7.G.3 Standard Pay Items

Construction items have been standardized for ease of identification and clarity in communication. There is a current listing of the standard pay items located on the **NDOT** website (<https://dot.nebraska.gov/business-center/business-opp/hwy-bridge-lp/item-history/>).

The standard pay item listing may be explored using the search function on the screen. An item may be identified in a variety of ways; for example, a search for the item “reinforcing steel” may be made using any of the following criteria:

- REINFORCING STEEL
- REINF
- STEEL
- 4163.25
- LB

All items which meet the criteria will be listed. A general term search will result in a very long listing of items (e.g. a search using “TON” will locate every pay item which is measured in tons).

If a pay item is required that does not appear in the standard pay item listing, **Cost Estimating** should be contacted for assistance.

### 7.G.4 New Materials

Construction projects sometimes require special treatments or solutions to problems that have not been encountered previously and for which standards have not been developed. At times new construction materials, which have not been included in previous projects, are accepted for use. The use of a new material may require a special provision (See Section 7.G.2 of this chapter).

Costs and/or special provisions for new materials must be researched both for their suitability and for their incorporation into the specifications and cost estimates. As early as possible in the design process, the roadway designer will provide the cost estimator with sufficient information regarding what the work consists of so that a reliable cost estimate may be made.

#### 7.G.4.a Sole Sourcing

On October 18, 2019, the **FHWA** revised 23 CFR 635 to allow the States greater flexibility in the use of patented or proprietary materials on Federal-aid projects; State DOTs are no longer required to provide certifications, make public interest findings, or develop research or experimental work plans for federal-aid participation. In response, **NDOT** issued Operating Instruction DOT-OI 60-19, "Use of Proprietary and State Furnished Items" (See Appendix B, "Selected NDOT Operating Instructions", of this manual) to provide policy for sole sourcing on **NDOT** projects. For additional information, see FHWA Docket No. FHWA-2018-0036 (<https://www.federalregister.gov/documents/2019/09/27/2019-20933/construction-and-maintenance-promoting-innovation-in-use-of-patented-and-proprietary-products>).

#### 7.G.5 Quantities

Pay items may be specified and described in several ways. For example, based on weigh scale location and availability, **Districts 1, 2, and 3** pay for aggregate by the Ton while **Districts 4 through 8** pay for aggregate by the cu. yd. The appropriate standard pay item unit of measurement will be used based on the project location. The units of measurement for items specified on the project plans should be consistent with the units of measurement of the standard pay items. The degree of accuracy applied to each unit of measure can be found in EXHIBITS 12.6 & 12.7.

The roadway designer should keep notes regarding the development of the quantities and lump sum items for each estimate. The notes should include the assumptions made in producing the quantities, for example the roadway designer may include the assumption that the project will be built under traffic. That assumption should be recorded in the project file and also should be shared with the cost estimator so that conflicting assumptions are not made at a later date and/or by others involved.

Quantities will be calculated for every construction pay item pertaining to a given project. EXHIBIT 12.3 presents a partial listing of quantity calculation guidance found in this manual and in the Drainage Design and Erosion Control Manual (*Drainage Manual*) (Ref. 12.4) (<https://dot.nebraska.gov/business-center/design-consultant/rd-manuals/>). The "Cost Estimate Checklist" and the "Pavement Item Checklist" (EXHIBIT 12.8 and EXHIBIT 12.9) are helpful references for items to be included in the cost estimate.

<b>Roadway Design Manual</b>		
<b>Item</b>	<b>Chapter</b>	<b>Section</b>
Bridge Channel Work	13	5.B.6.a
Cold Milling	8	5.B.1
Crossovers	14	6.A.1
Delineators	14	3
Earthwork	7	1
Guardrail Quantities	9	9
Mailbox Turnouts/Supports	10	10
Old Road Obliteration	10	9
Pavement Patching	8	5.C
Re-establishing Land Monuments and Property Corners	15	7.B
Right-of-Way Markers	15	7.A
Rumble Strips	8	7
Shoulder Construction	8	4
Surfacing Quantities	8	6
Temporary Road Pay Items	14	6.B
Temporary Surfacing	14	6.A.2
<b>Drainage Design and Erosion Control Manual</b>		
<b>Item</b>	<b>Chapter</b>	<b>Section</b>
Culvert Excavation	1	8.R
Culvert Lengths	1	8.D
Permanent Erosion and Sediment Control Measures	2	6
Riprap	2	7.A
Temporary Erosion and Sediment Control Measures	2	5

**Note:** This is not a complete listing. The roadway designer should refer to the Standard Specifications for Highway Construction (Ref. 12.3) and the appropriate Sections of the Roadway Design Manual and the Drainage Design and Erosion Control Manual (Ref. 12.4) for guidance when computing project quantities.

### Exhibit 12.3 Quantity Calculation Guidance Locations

### 7.G.6 Traffic Control Items

For Cost Update 1 (Status Code 30, "Design Phase"), Cost Update 2 (Status Code 40, "Environmental Approval Phase"), and Cost Update 3 (Status Code 45, "Plan Details Phase") a lump sum amount is used for temporary traffic control items. **Cost Estimating** calculates this sum based on the type of work involved. This lump sum estimate includes the following items:

- Barricades Type III
- Temporary Signs
- Flashing Arrow Panels
- Flagging

The **Construction Division** provides the roadway designer with quantities for the above items for the PS&E Estimate (Status Code 50, "Plan Package Phase").

The items found below are not included in the **Construction Division** cost estimate. Quantities must be furnished for these items when they are needed on a project. The roadway designer will coordinate with **Traffic Engineering** on quantities for the below items for Cost Update 1 (Status Code 30, "Design Phase"), Cost Update 2 (Status Code 40, "Environmental Approval Phase"), and Cost Update 3 (Status Code 45, "Plan Details Phase").

- Temporary Traffic Signals
- Concrete Protection Barriers
- Temporary Pavement Markings
- Impact Attenuators
- Inertial Barrier Systems
- Temporary Safety Lighting

**Traffic Engineering** will review the traffic control plans and provide final quantities and special provisions for items in the traffic signals, permanent signing, and the permanent pavement marking categories (Group #8) for the PS&E Estimate (Status Code 50, "Plan Package Phase"). For additional information see Chapter Fourteen: Traffic of this manual.

### 7.G.7 Bridge Items

Bridge construction may involve building a new bridge, widening, rehabilitating or repairing an existing structure. The type of structure must be included in the detailed cost estimate (e.g. Deck Steel Girder Bridge) because the type affects the cost for new and rehabilitated bridges. The preliminary bridge cost estimates are calculated based on the bridge dimensions (as shown in [EXHIBIT 12.4](#)) until detailed bridge item quantities are available. The area of the bridge structure is based on out-to-out measurements, not the clear roadway width except for overlays, which are based on the clear width.

The following bridge items are included in the preliminary bridge cost estimate:

- The bridge materials
- Preparation of the existing structure
- Excavation and backfill for abutments and piers
- Riprap
- Slope protection
- Painting of structures

The preliminary bridge cost estimate will also include items that are ultimately the responsibility of **Roadway Design** (e.g. guardrail, temporary roadway grading and surfacing, excavation for Concrete Box Culverts). When assigned a project which includes bridge and bridge-sized structures the roadway designer will review the “Planning Bridge Determination”, placed in OnBase by the **Bridge Management Section**, for a detailed breakdown of the items included in the preliminary bridge cost estimate from **Bridge**. As the design of the project progresses and the roadway designer establishes quantities for the roadway items that have been included in the preliminary bridge cost estimate the roadway designer will remove those items, and their cost, from the preliminary bridge cost estimate. When submitting an estimate request, the roadway designer will inform **Cost Estimating** of the reduction in the preliminary bridge cost estimate and its cause.

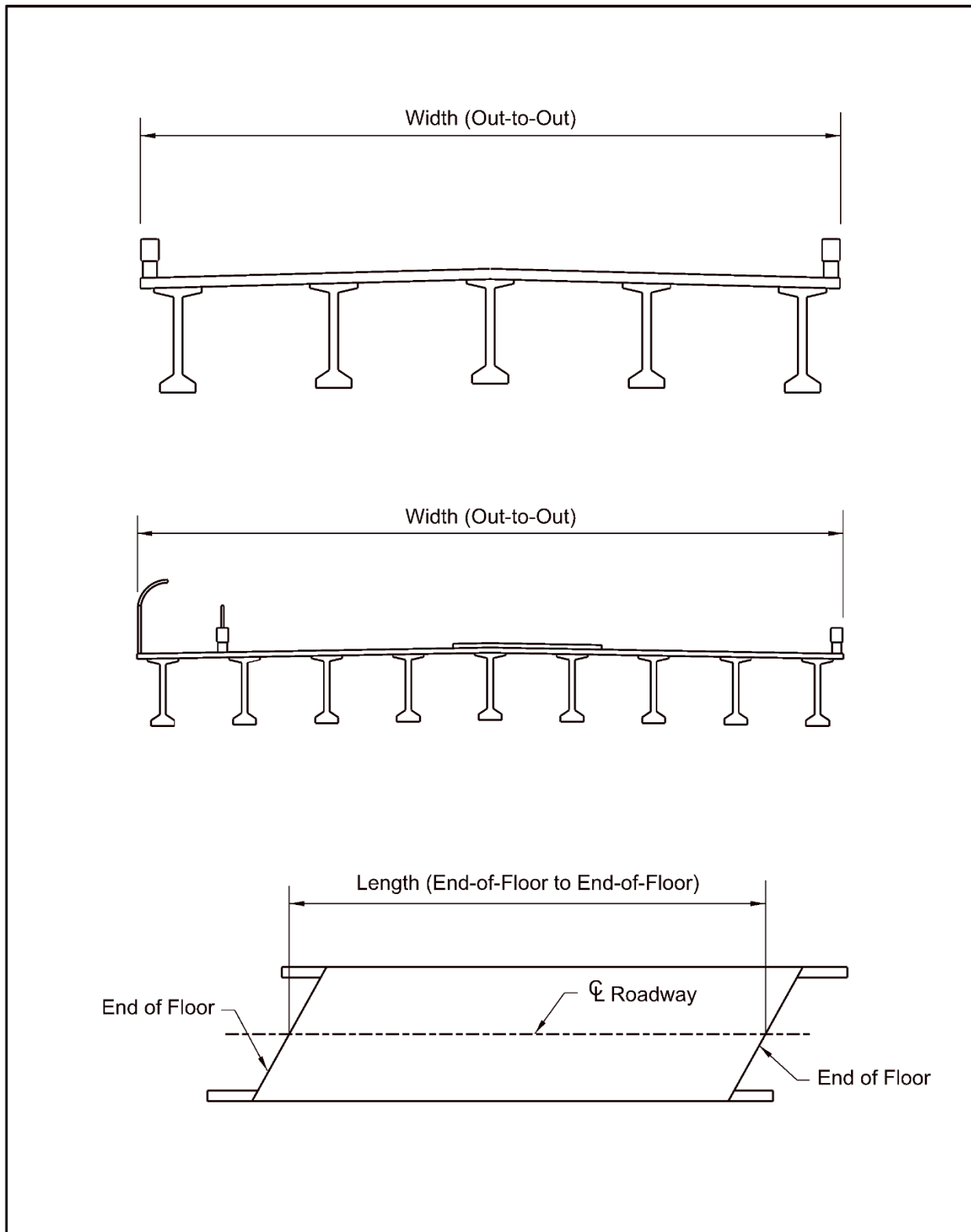
The bridge designer will provide the roadway designer with detailed bridge construction quantities for inclusion in the PS&E turn-in packet.

The following items *are not* included in the detailed bridge construction estimate, the roadway designer shall include these items in the PS&E Estimate (Status Code 50, “Plan Package Phase”) as required:

- Channel work (See Chapter Thirteen: [Planning and Project Development](#), Section 5.B.6, of this manual)
- Retaining walls
- Mechanically stabilized earth (MSE) walls

For additional information see Chapter Ten: [Miscellaneous Design Issues](#), Sections 2 and 8, of this manual.





**Exhibit 12.4 Dimensions to Use in Calculating Area of Bridge Structures**

### 7.G.8 Other Construction Items

PDD will provide information for cost items related to wetlands and noise walls (See Chapter Thirteen: Planning and Project Development, Sections 5.B and 5.D of this manual), for landscaping items (such as tree and shrub plantings), and for erosion control items (See Chapter Ten: Miscellaneous Design Issues, Section 4, of this manual and the *Drainage Manual* (Ref. 12.4), Chapter Two: Erosion Control).

The **ITS/Lighting Unit (ITS/Lighting)** in **Roadway Design** will provide the roadway designer with specifications and estimates if lighting is included in the project. For further information, see Chapter Ten: Miscellaneous Design Issues, Section 13, of this manual.

## 8. ITEMS AFFECTING CONSTRUCTION COSTS

Construction costs are affected by a variety of factors, such as supply and demand for individual items of material and the cost of labor. The following items are provided for the designer's information. If these items impact a project, the designer should verify that the effects on project costs have been included in the cost estimate received from **Cost Estimating**.

### 8.A Construction Schedule

The construction schedule may affect the cost of construction. For example, complicated work sequences or wintering a project may increase the construction costs while economies of scale (e.g. buying materials in bulk, keeping workers occupied by shifting crews between projects) may reduce the construction cost if projects in close proximity are combined.

### 8.B Construction Location

The location of the project, accessibility to the site, and the availability of materials also affect the project cost.

#### 8.B.1 Site-Specific Features

Site-specific features will impact the cost. For example:

- Rock Excavation
- Sandhills Vegetation (Fertilizer)
- De-watering
- Storm Water Treatment
- Environmental Considerations

#### 8.B.2 Urban/Rural

Urban locations often have higher construction costs than rural sites due to higher costs of right-of-way acquisition, greater traffic control requirements, pedestrian accessibility, pedestrian accessibility during construction, utility relocations, more access points, etc. Congestion may necessitate nighttime construction scheduling, which would also impact costs.

### **8.C Maintaining Traffic During Construction**

Phasing - The phasing of construction activities while maintaining reasonable traffic flow and pedestrian access is an important design consideration and an added cost to the project. Phasing for a project is preferably determined during the “Planning Phase” (Clarity Activity 5200) prior to the plan-in-hand field inspection. Traffic control measures (e.g. barricades, signs, markings, flaggers) are an integral part of the project and add to its cost. Additional temporary surfacing may be needed for lane or shoulder widening or to provide access to properties. These surfacing quantities will be included in the cost estimate and paid for separately.

Detours - If detours require temporary improvements to the geometry and surfacing of the route, the construction and maintenance of the improvements are project costs. Pavement needed for detour improvements is paid for under a separate pay item group. Signage, public notification, and other costs associated with detours also impact the total project cost.

Temporary Roads – If temporary roads are built to route traffic around construction, the costs associated with the temporary road (e.g. surfacing quantities, culverts, erosion control, traffic control measures) will add to the total project cost.

Night Work – When phasing of projects causes significant impact to traffic operations, night work may be needed for construction. Cost for construction may need to be inflated and should be noted in the cost estimate.

For additional information see Chapter Fourteen: Traffic, Section 6 and Chapter Sixteen: Pedestrian and Bicycle Facilities, Section 11, of this manual.

## **9. ITEMS OFTEN OVERLOOKED OR OMITTED**

Requests for cost estimates should only be made after a careful review of the items included in the request. The roadway designer should understand which elements are included in each pay item and how the items relate to one another. Failure to include the proper information in a cost estimate may result in costly delays and extra work while the changes are made. EXHIBIT 12.5 is a partial listing of estimate items which are often omitted and items subject to misinterpretation.

<b>Changes in Pavement Determination:</b>	These changes require updating the quantities.
<b>Covercrop Seeding:</b>	This should be used when there is a major grading project and the permanent seeding is to be done at a later date. In the Sandhills Region, Slope Protection is used in lieu of Covercrop and Types A & B Seeding.
<b>Detour Group (#2, 2A, or 9A):</b>	This group should not be overlooked. Consult with the <b>DE</b> to determine if gravel surfacing is required. Include temporary road surfacing and temporary connections. Additionally, some projects will require winter gravel. Contact <b>Traffic Engineering</b> regarding the need for temporary signals.
<b>Engineering and Contingencies:</b>	See Sections 7.E and 7.F of this chapter.
<b>Erosion Control and Temporary Erosion Control:</b>	These costs are frequently underestimated. The roadway designer should coordinate the design with the <b>Roadside Development Unit</b> in <b>PDD</b> and with the <b>District</b> . Temporary erosion control must be placed at the end of each working day. Even though the actual placement will be determined by the contractor and the <b>District</b> as the situation warrants, the roadway designer shall include a total for the project in the estimate.
<b>Flared End Sections:</b>	Split out those flared end sections that must be metal or concrete (e.g. if extending a concrete pipe with Culvert Pipe Type 2, the appropriate pay item is Concrete Flared End Sections). Some projects will have three FES quantities, for example: 24 inch Metal FES, 24 inch Concrete FES, and 24 inch FES.
<b>Foundation Course:</b>	This is equal to the sq. yd. of surfacing.
<b>General Clearing and Grubbing:</b>	“General Clearing and Grubbing” may be used by itself in a few cases (e.g. Sandhills areas) where no trees or stumps could be found over 24 inches in diameter. In these cases the “Grading Item Summary Sheet” will be submitted to <b>PS&amp;E</b> stating that “No large trees or stumps were found”.
<b>Gravel Embedment:</b>	This item should be used for gravel frontage roads, county roads, and driveways (drive returns are not included). This pay item does not include furnishing the gravel.

**Exhibit 12.5 Estimate Items Often Overlooked or Omitted**

<b>Hydrated Lime for Warm Mix Asphalt:</b>	This item will be used with asphaltic concrete projects.
<b>Items Done by Other Governmental Agencies:</b>	Sometimes some construction items are performed by other governmental agencies (e.g. surfacing of a detour). These items are still project costs and will be included in the estimate.
<b>Jacking Pipes:</b>	This is used on phased projects where new culvert is at a new location. Jacking pipe does not include the cost of the culvert pipe and a higher class of pipe may be required for jacking (See Chapter One, Section 13.C of the <i>Drainage Manual</i> , Ref. 12.5).
<b>Large Tree Removal:</b>	Required on projects where the trees or stumps to be removed are larger than 80 inches in circumference. The number of trees should be estimated, even if a tree count survey is not available. "One Each" should not be listed; this can produce unbalanced bids where a contractor will use a very large unit price, knowing that the quantity will be much higher. This item is in addition to "General Clearing and Grubbing".
<b>MSE Walls:</b>	This item is the responsibility of the roadway designer; it is not included in the <b>Bridge</b> estimate.
<b>MS4 Community Stormwater Treatment Installations:</b>	In many cases stormwater treatment for MS4 Communities (See Chapter Three of the <i>Drainage Manual</i> , Ref. 12.5) will be included in other project costs (i.e. "Grass Swales" quantities are integral to grading and seeding). For unique installations, such as a "Principal Spillway", the roadway designer will coordinate with the <b>Environmental Liaison Engineer</b> in <b>Roadway Design</b> to determine the necessary pay items to be included in the project estimate.
<b>Preliminary Engineering:</b>	See <a href="#">EXHIBIT 12.2</a> for the appropriate cost factor. Please check the appropriate box on the "Project Information Sheet" (See Section 5.A of this chapter).
<b>Railroad Involvement:</b>	A project which is adjacent to or crosses railroad property may require estimate items for such items as right-of-way easements, surfacing, railroad crossings, signals and communication lines. The roadway designer should coordinate with the <b>Rail Unit</b> in the <b>Local Assistance Division</b> regarding the necessary estimate items. If a detour crosses a railroad, the roadway designer should contact the <b>Rail Unit</b> regarding the need for temporary signalization.

**Exhibit 12.5 Estimate Items Often Overlooked or Omitted**

<b>Related Construction Items:</b>	Be sure that related items are included. For example:  “Concrete Pavement” should be accompanied by “Subgrade Preparation” and “Foundation Course”.  “Subgrade Preparation” should be accompanied by “Water, Applied”.  Excavation pay items should be accompanied by “General Clearing and Grubbing”, “Large Tree Removal”, and “Water, Applied”.
<b>Relocation Costs:</b>	The roadway designer will verify that relocation costs are included in the <b>ROW Division</b> estimate before submitting the project to <b>PS&amp;E</b> .
<b>Remove Sign, Post, and Footing:</b>	The relocation of most signs is paid for by the <b>ROW Division</b> but the removal of the footing is usually a contract item requiring a build note and a project quantity. The pay item “Clear Tract” covers the removal of the sign, post, and footing. When “Clear Tract” is not used, the pay item “Remove Sign, Post, and Footing” will be added to the quantities.
<b>Salvage and Place Topsoil:</b>	This will be used when the embankment is, or could be, granular material. If the contractor is to furnish borrow and it is likely that the contractor will furnish granular embankment, the Special Provisions will state that the contractor must salvage and place topsoil. This would also be a special circumstance and the unit price should account for this.
<b>Sawing Pavement</b>	See Chapter Eight: <u>Surfacing</u> , Section 6.E, of this manual
<b>Shoulder Construction:</b>	Pay for “Shoulder Construction” when overlaying an existing roadway. This will not be calculated when “Shoulder Subgrade Preparation” is a pay item.
<b>Shoulder Subgrade Preparation:</b>	“Shoulder Subgrade Preparation” will be paid for when adding surfaced shoulders to an existing roadway. Do not calculate “Shoulder Construction” when this is a pay item.
<b>Sign Supports:</b>	Contact <b>Traffic Engineering</b> to determine if sign supports will be required on the project. Sign supports are often included in interchange designs. The roadway designer should also check for other traffic items, such as traffic signals.
<b>Subgrade Preparation:</b>	This is equal to the sq. yd. of surfacing.
<b>Subgrade Stabilization:</b>	This item is a replacement for “Subgrade Preparation”. The same segment of roadway should not have both items in the estimate.

**Exhibit 12.5 Estimate Items Often Overlooked or Omitted**

<b>Temporary Access:</b>	On rural and urban new and reconstructed projects which disrupt access to adjacent property, the roadway designer should discuss the use of gravel, crushed rock, or millings with the <b>DE</b> at the plan-in-hand and include a lump sum quantity for temporary access in the cost estimate. The quantities should vary between 100 to 200 tons per mile, depending on the size of the access and the type of roadway (two-lane vs four-lane, rural vs urban). These quantities are for design purposes only. The quantities should be shown to the nearest ton.
<b>Temporary Shoring:</b>	Temporary shoring is sheet piling used to hold the embankment when the earthwork operation is being phased in close proximity to traffic. It is also used when new bridge construction is too close to an existing bridge.
<b>Traffic Control, Field Office, Mobilization:</b>	These items will be added by <b>Cost Estimating</b> .
<b>Traffic Control Items:</b>	See Section 7.G.6 of this chapter for those items which <i>are not</i> included in the estimate provided by the <b>Construction Division</b> for the PS&E Estimate (Status Code 50, "Plan Package Phase").
<b>Traffic Signals, Permanent Signing, Roadway Lighting, etc.:</b>	The roadway designer will verify that these items are included in the estimate if they are a part of the project.
<b>Trenched Widening:</b>	Paid for when widening a roadway from an existing 24 foot wide to 28 feet.
<b>Unusual Circumstances:</b>	Known special circumstances that will affect the contractor's bids should be noted. For example, rock excavation, long hauls, unsuitable materials, phased construction, etc. will affect the contractor's bids.
<b>Utilities:</b>	Utilities can be a major project cost. The roadway designer should take this into account when designing and try to avoid the need for expensive rehabilitation. A major utility rehabilitation must be included in the estimate, <i>do not</i> use the standard 2.9% of project cost.
<b>Utilities – City Owned:</b>	Generally, utilities located within corporate limits will be a project cost and must be included in the estimate. Reimbursement of a city-owned utility located outside of corporate limits depends on whether the utility is located within state right-of-way. This should also be accounted for during design to avoid possible conflicts.
<b>On-Site Wetland Mitigation:</b>	This item can be very costly and may necessitate the purchase of additional right-of-way. The roadway designer should coordinate with the <b>Technical Resources Unit (TRU)</b> of the <b>Environmental Section</b> in <b>PDD</b> on an approximate area of wetlands involved and on the cost.

**Exhibit 12.5 Estimate Items Often Overlooked or Omitted**

UNIT	APPLIES TO	ACCURACY
Each	Contract items with a unit of each	Whole number
Cu. Yd.	Contract items with a unit of cubic yard except: 1. Aggregate surfacing items 2. Concrete 3. Base course material, granular foundation course material, sand soil binder, filler & material aggregates	Nearest cu. yd. Nearest 5 cu. yd. 0.01 cu. yd. Nearest 10 cu. yd.
Sq. Yd.	Contract items with a unit of square yard	Nearest 1 sq. yd.
Sq. Ft.	Contract items with a unit of square foot	Nearest 1 sq. ft.
Mile	Contract items with a unit of mile	0.001 Mile
Station	Contract items with a unit of station	0.001 Sta.
Lin. Ft.	Contract items with a unit of linear foot except: 1. W-beam/Thrie-beam guardrail 2. Cable guardrail 3. Bridge railing, handrail, etc. 4. Wood sign supports 5. Concrete protection barriers 6. Culvert Pipe	Nearest 1 lin. ft. Nearest 0.5 lin. ft. Nearest 1 lin. ft. Nearest 0.01 lin. ft. Nearest 0.5 lin. ft. Nearest 1 lin. ft. Nearest 1 lin. ft.
Vert. Ft.	Contract items with a unit of vertical foot	0.1 ft
Day	Contract items with a unit of day	Nearest 0.5 day
Ton	Contract items with a unit of ton except: Asphaltic concrete	Nearest 1 ton Nearest 10 tons
Cu. Yd. Sta.	Contract items with a unit of cubic yard station	Nearest 1 cu. yd. Sta.
Acre	Contract items with a unit of acre	Nearest 1 acre
M Sq. Yd.	Contract items with a unit of thousand square yards	Nearest M sq. yd.
Hour	Contract items with a unit of hour	Nearest 1 hour
Lb.	Contract items with a unit of pound	Nearest 1 lb.
Gal.	Contract items with a unit of gallon	Nearest 10 gal.
MGal.	Contract items with a unit of thousand gallons	Nearest MGal

**Exhibit 12.6 Pay Item Accuracy**

ITEM	ENGLISH
Subgrade Preparation	0.001 STA
Subgrade Preparation	1 SY
Subgrade Stabilization	0.001 STA
Water	1 Mgal
Soil Binder	10 CY
Asphaltic Concrete	10 Ton
Asphalt Cement	0.005 Ton
Tack Coat	10 Gal
Shoulder Constructions	0.001 STA
Preparation of Intersections and Driveways	1 SY
Placement of Asphaltic Concrete for Driveways and Intersections	1 SY
Concrete Pavement	1 SY
Foundation Course	10 Ton
Foundation Course	1 SY
Concrete Driveway	1 SY
Cold Milling	0.001 STA
Salvaging and Stockpiling Bituminous Material	10 Ton
Gravel Surface Course	10 CY
Gravel Surface Course	10 Ton
Gravel Embedment	0.001 STA
Removing, Crushing, Screening and Stockpiling old Concrete Pavement	1 SY

**Exhibit 12.7 Rounding of Surfacing Item Quantities**



<b>Group #1 - Grading</b>	
Removing Trees and Stumps General Clearing and Grubbing Covercrop Seeding Traffic Control Devices Field Lab, Type "C" Mobilization Excavation Excavation Borrow Earthwork Measured in Embankment Removal of Unsuitable Material Excavation (Established Quantity) Embankment for Surcharge (Established Quantity) Roadway Grading Water Applied ROW Markers Resetting ROW Makers Salvage and Place Topsoil Salvage and Stockpile Topsoil Slope Protection Erosion Control Erosion Checks Broken Concrete Riprap Driveway Culvert Pipe Round Equivalent Driveway Culvert Pipe Abandoned Manholes Relaying Driveway Culvert Pipe Backslope Pipes Median Pipes Temporary Surfacing Clear Tract No. _____ Gravel/Rock Surface Course for Temp. Access Temporary Shoring Remove Existing Slab Restoration of Borrow Pits Gabions, Type _____	Abandoned Wells Building Inertial Barrier Modules Fill Material for Inertial Barrier Modules Retaining Walls Chain Link Fence Salvaging and Stocking Bituminous Material Silt Fence Fabric Silt Checks Wetland Mitigation Wetland Seeding or Salvaging and Stockpiling Hydric Soil MSE Walls – Four Items Removals: Pavement, Asphalt Surface, Gutter, Driveway, Sidewalk Removing Combination Curb and Gutter Removing Curb Removing Manholes Removing Tank Removing Inlets Removing Existing Drive Pipe – Salvage Removing Existing Guardrail Removing Brick Surfacing Removing Existing Slope Curb Removing Fence Removing Steps Removing Retaining Walls Removing Ditch Checks Removing Catch Basins Removing Junction Boxes Removing Discharge Structures Removing Flumes Removing Median Surfacing Removing Ditch Lining Removing Existing Buildings
<b>Group #2, 2A, or 9A - Detour</b>	
Traffic Control Devices Gravel Surface Course Temporary Road Surfacing Temporary Signals Temporary Bridge Temporary Lighting Temporary Railroad Crossing/Signals	Crushed Rock Surface Course Calcium Chloride, Applied Gravel Embedment Winter Gravel Crossovers Temporary Gravel

Notes: This is not a complete listing, review the rest of Chapter Twelve for additional information.  
 The responsibility of the roadway designer regarding some estimate items will change as the project progresses (e.g. Asphalt Surfacing items)

**Exhibit 12.8 Cost Estimate Item Checklist**

<b>Groups #3 and #9 - Surfacing</b>	
Traffic Control Devices	Concrete Pavement, Type ____
Field Laboratory, Type B	(Patching Concrete with Concrete)
Mobilization	Pavement Patching, Type ____
Surfacing Under Guardrail	(Patching Concrete with Asphalt)
Delineators, Type ____	Pipe Underdrains
Gravel or Crushed Rock Surface Course (for Intersections and Driveways)	Granular Subdrains
Gravel Surface Course	Concrete Pavement
Grave Embedment	Reinforced Concrete Pavement
Special Surface Course for Mailbox Turnouts	Asphalt Concrete Type ____
Mailbox Posts	Asphalt Concrete for Patching
Sodding	(Include with Roadway Asphalt)
Placing Topsoil	Asphalt Concrete for Intersections and Drives
Breaking Pavement Concrete Curb	Asphaltic Concrete for Median Surfacing
Concrete Island Curb	Asphalt Oil for Prime Coat
Concrete Median Curb	Emulsified Asphalt for Tack Coat
Concrete Barrier Curb	Asphalt Cement for Asphalt Concrete
Concrete Combination Curb and Gutter	Constructing Asphalt Concrete Curb
Concrete Sidewalk	Constructing Asphalt Concrete Flumes
Concrete Median Surfacing	Constructing Asphalt Concrete Island Nose
Concrete for Island Nose	Preparation for Expansion Joints
Concrete Median Barrier	Preparation of Intersections and Drives, Type "A", "B", and "C"
Concrete Driveways	Rental of Loader, Motorgrader, and/or Dump Truck
Foundation Course (Bituminous)	Water Applied
Foundation Course (Regular)	Shoulder Construction
Foundation Course (Crushed Concrete)	Shoulder Subgrade Preparation
Adjust ____ Box to Grade (Curb Stop, Valve, Roadway, etc.)	Subgrade Reconstruction
Reconstruct Manhole to Grade	Median Construction
Adjust Manhole to Grade	Subgrade Preparation
Soil Aggregate Base Course	Subgrade Stabilization
Slope Drains	Soil Binder for Subgrade Stabilization
Flumes, Type ____	Armor Coat
15 inch Corrugated Culvert (for Flumes)	Bituminous Sand
Soil Aggregate Base Course	Crushed Rock Surface Course
Milling, Class ____	
Concrete Base Course Widening	

Notes: This is not a complete listing, review the rest of Chapter Twelve for additional information.  
 The responsibility of the roadway designer regarding some estimate items will change as the project progresses (e.g. Asphalt Surfacing items)

**Exhibit 12.8 Cost Estimate Item Checklist**

<b>Group #4 - Culverts</b>	
Traffic Control Devices Mobilization Cast-Iron Covers, Frames, Grate Rings, Flanges Removing Existing FES Removing Existing Headwalls Preparation of Existing Structure Remove Existing Structure Excavation for Box Culverts Excavation for Culvert Pipes and Headwalls Culvert Pipe Corrugated Metal Pipe Jacking Reinforced Concrete Sewer Pipe Jacking Reinforced Concrete Sewer Pipe, Class ____ Reinforced Concrete Pipe, Class IV Reinforced Concrete Pipe, Class V Reinforced Concrete Pipe Reinforced Concrete Sewer Pipe Clay Sewer Pipe Culvert Sand-fill Flared End Sections Metal Flared End Sections Concrete Flared End Sections Bar Grates for Flared End Sections Concrete for Box Culverts Concrete for Headwalls, Steps, Catch Basins, Collars, Retaining Walls, and Plugs	Reinforced Steel for Box Culverts Reinforced Steel for Steps, Catch Basins, Collars, and Retaining Walls Damp-proofing Jacking Steel Casing Slope Drains Flumes, Type ____ Flume Spillway Cast Iron Covers, Frames, Grates, Rings, Flanges Area Inlets Junction Box Build Manholes Irrigation Structures Remove Sewer Pipe Tapping Existing Manhole Tapping Existing Structure Tapping Existing Culvert Inlet Riser Relocating Corrugated Metal Pipe, Reinforced Concrete Pipe Rock Riprap and Filter Fabric Concrete for Inlets and Junction Boxes Steel for Inlets and Junction Boxes Temporary Shoring
<b>Group #5 - Landscaping</b>	
Traffic Control Devices Seeding, Type ____	Fabric Silt Checks Landscaping
<b>Group #6 - Bridge</b>	
Traffic Control Devices Mobilization MSE Walls – Four Items Major Riprap Channel Lining Concrete for Pavement Approach Slabs	Reinforced Steel for Pavement Approach Slabs Bridges (sq. ft.) Bridge Removal Channel Change

Notes: This is not a complete listing, review the rest of Chapter Twelve for additional information.  
 The responsibility of the roadway designer regarding some estimate items will change as the project progresses (e.g. Asphalt Surfacing items)

**Exhibit 12.8 Cost Estimate Item Checklist**

<b>Group #7</b>	
Traffic Control Devices W-Beam or Thrie-Beam Guardrail End Treatment Type ____ (I or II) Bullnose 12.5' Special Guardrail Posts, Type ____ Guardrail and Accessories (Bridge Approach Section, End Shoe, etc.) Removing and Resetting Safety Beam Guardrail	Cable Guardrail/Anchorage Assembly Remove and Reset Right-of-Way Fence Terminal Anchorage Section Guard Posts Right-of-Way Fence and Accessories Chain Link Fence and Accessories Gates
<b>Group #8</b>	
Traffic Control Devices Lighting Signalization	Sign Supports Permanent Signing
<b>Miscellaneous Group</b>	
Noise Walls Railroad Crossings/Signals/Communications Irrigation Structures	Non-Betterment City Utilities Relocation Water Retention Structures Any Engineering or Construction by Others
<b>Other Project Costs</b>	
Calculated by Others See <a href="#">EXHIBIT 12.2</a>	

Notes: This is not a complete listing, review the rest of Chapter Twelve for additional information.  
 The responsibility of the roadway designer regarding some estimate items will change as the project progresses (e.g. Asphalt Surfacing items)

**Exhibit 12.8 Cost Estimate Item Checklist**

**Asphaltic Concrete Surfacing**

Asphaltic Concrete, Type "\*\*\*"  
Performance Graded Binder (xx\_xx)  
Hydrated Lime for Asph. Mixtures  
Cold Milling, Class "\*\*\*"  
Tack Coat  
Earth Shoulder Construction  
Shoulder Subgrade Preparation (Includes Shoulder Construction)  
Water

**Asphaltic Concrete Full Depth Construction**

Asphaltic Concrete, Type "\*\*\*"  
Performance Graded Binder (xx\_xx)  
Hydrated Lime for Asph. Mixtures  
Tack Coat  
Earth Shoulder Construction  
Shoulder Subgrade Preparation (Includes Shoulder Construction)  
Subgrade Construction  
Subgrade Preparation  
Water

**Bituminous Sand Base Course**

Asphaltic Oil or Emulsified Asphalt  
Mineral Filler  
Fog Seal  
Water

**Bituminous Surface Course**

Bituminous Surface Course  
Fog Seal

**Portland Cement Concrete Full Depth Construction**

Foundation Course (Aggregate, Bituminous, Crushed Conc., etc.) - optional, see pavement determination  
Drainage (Subgrade)  
Subgrade Preparation  
Earth Shoulder Construction  
Shoulder Subgrade Preparation (Includes Shoulder Construction)  
Water

**Temporary Road or Detour**

Gravel Embedment  
Gravel Surface Course  
Calcium Chloride, Applied - use if required by District  
Subgrade Preparation  
Earth Shoulder Construction  
Water  
Temporary Surfacing

QUANTITY AND AREA COMPUTATIONS FOR GRAVEL AND CRUSHED ROCK																	
The table below gives the area (in sq. yds.) and quantities (in cu. yds.) for various roadway widths, distances, and depths.																	
Width of Roadway	Sq. Yds		1 in. Depth			1 1/2 in. Depth			2 in. Depth			2 1/2 in. Depth			3 in. Depth		
	Per Sta.	Per Mile	1 Cu. Yd. covers Lin. Ft.	Cu. Yds. Per	Per	1 Cu. Yd. covers Lin. Ft.	Cu. Yds. Per	Per	1 Cu. Yd. covers Lin. Ft.	Cu. Yds. Per	Per	1 Cu. Yd. covers Lin. Ft.	Cu. Yds. Per	Per	1 Cu. Yd. covers Lin. Ft.	Cu. Yds. Per	Per
10	111.11	5866.7	32.40	3.09	162.96	21.00	4.63	244.44	16.20	6.17	325.93	12.96	7.72	407.41	10.80	9.26	488.59
11	122.22	6453.3	29.45	3.40	179.26	19.64	5.09	268.89	14.73	6.79	358.52	11.78	8.49	448.15	9.82	10.19	537.78
12	133.33	7040.0	27.00	3.70	195.56	18.00	5.56	293.33	13.50	7.41	391.11	10.80	9.26	488.89	9.00	11.11	586.67
13	144.44	7526.7	24.92	4.01	211.85	16.62	6.02	317.78	12.45	8.02	423.70	9.97	10.03	529.63	8.31	12.04	635.56
14	55.56	8213.3	23.14	4.32	228.15	15.43	6.48	342.22	11.57	8.64	456.30	9.26	10.80	570.37	7.72	12.96	684.44
15	166.67	8800.0	21.60	4.63	244.44	14.40	6.94	366.67	10.80	9.26	488.89	8.64	11.57	611.11	7.20	13.89	733.33
16	177.78	9335.7	20.25	4.94	260.74	13.50	7.41	391.11	10.13	9.88	521.48	8.10	12.35	651.85	6.75	14.81	782.22
17	188.89	9973.3	19.06	5.25	277.04	12.71	7.37	415.56	9.53	10.49	554.07	7.62	13.12	692.59	6.35	15.74	831.11
18	200.00	10560.0	18.00	5.56	293.33	12.00	8.33	440.00	9.00	11.11	586.67	7.20	13.89	733.33	6.00	16.67	880.00
19	211.11	11146.7	17.05	5.86	309.63	11.37	8.80	464.44	8.53	11.73	619.26	6.82	14.66	774.07	5.69	17.59	928.89
20	222.22	11733.3	16.20	6.17	325.93	10.80	9.25	488.89	8.10	12.35	651.85	6.48	15.43	814.81	5.40	18.52	977.78
21	233.33	12320.0	15.43	6.48	342.22	10.29	9.72	513.33	7.72	12.96	684.44	8.17	16.20	855.56	5.14	19.44	1026.67
22	244.44	12905.7	14.73	6.79	353.52	9.82	10.19	537.78	7.36	13.58	717.04	5.89	16.98	895.30	4.91	20.37	1075.56
23	255.56	13493.3	14.09	7.10	374.81	9.39	10.65	562.22	7.04	14.20	749.63	5.63	17.75	937.04	4.70	21.30	1124.44
24	266.67	14080.0	13.50	7.41	391.11	9.00	11.11	586.67	6.75	14.81	782.22	5.40	18.52	977.78	4.50	22.22	1173.33
25	277.78	14666.7	12.95	7.72	407.41	8.64	11.57	611.11	6.48	15.43	814.81	5.18	19.29	1018.52	4.32	23.15	1222.22
26	288.89	15253.3	12.45	8.02	423.70	8.31	12.04	635.56	6.23	16.05	847.41	4.98	20.06	1059.26	4.15	24.07	1271.11
27	300.00	15840.0	12.00	8.33	440.00	8.00	12.50	660.00	6.00	16.67	880.00	4.80	20.83	1100.00	4.00	25.00	1320.00
28	311.11	16426.7	11.57	8.64	456.30	7.71	12.96	684.44	5.79	17.28	912.59	4.63	21.60	1140.74	3.86	25.93	1368.89

# 2 Gravel for Surfacing = 1.35 Tons/Cu. Yd.  
 Crushed Rock for Surfacing = 1.25 Tons/Cu. Yd.

Aggregate paid for by the Ton in Districts 1, 2, and 3. Aggregate paid for by the Cu. Yd. in Districts 4 through 8. Consult with the DE on the PIH to determine the Unit of measurement to be used.

Exhibit 12.10 Quantity Computations for Gravel and Crushed Rock

<b>ESTIMATING QUANTITIES - 4/19/2022</b>	
<i>(Referenced to the 2017 NDOT Standard Specifications for Highway Construction)</i>	
<b>General Information</b>	
Items are listed in alphabetical order.	
RAP is an acronym for Recycled Asphalt Pavement, other term used is Bituminous Millings	
Weight of RAP = 144 lbs./ft <sup>3</sup>	
One gallon of emulsified asphalt or water weighs 8.333 lbs.	
Beveled edges in asphalt and concrete pavements are subsidiary. The required material is included in asphalt tons or concrete square yards.	
<b>Asphaltic Concrete Projects</b> –Add the following equipment rental items and hours.	
“Rental of Loader, Fully Operated” – 15 Hour	
“Rental of Motor Grader, Fully Operated” – 15 Hour	
“Rental of Dump Truck, Fully Operated” – 15 Hour	
“Rental of Skid Loader, Fully Operated” – 15 Hour	
<b>Armor Coat – Section 515</b>	
“Armor Coat Aggregate” – Cubic Yard	23 lbs./yd <sup>2</sup> (conversion factor 1.3 ton = 1 yd <sup>3</sup> )
“Armor Coat Emulsified Asphalt” - Gallon	0.34 Gal/yd <sup>2</sup>
<b>Asphaltic Concrete – Section 503, Section 1028, &amp; Special Provision</b>	
“Asphaltic Concrete, Type ____” – Ton	(See EXHIBITS 12.12 & 12.14 for types and weight)
Include material required for beveled edge.	
“Hydrated Lime/WMA” – Each	(See EXHIBIT 12.13)
“RAP Incentive Payment” - Each	Asphaltic Concrete Type “***” tons x 1.7 = Each
<b>Asphaltic Concrete Curb – Section 505</b>	
“Constructing Asphaltic Concrete Curb” – Linear Foot	
Factor for 3” Curb	1.35 Ton/Sta.
Factor for 4” Curb	2.00 Ton/Sta.
Factor for 6” Curb	2.10 Ton/Sta.
Factor for Tack Coat	1.0 Gal/Sta.
<b>Asphaltic Concrete for Patching – Section 516</b>	
“Asphaltic Concrete for Patching, Type “____” - Ton	
<b>Asphaltic Pavement Smoothness Testing ID – Section 502 &amp; Special Provision</b>	
<b>Superpave Quality and Asphalt Smoothness Testing I/D – Special Provision</b>	
“Superpave Quality and Asphalt Smoothness Testing I/D” – Each	
(excluding SPS, maintenance tons and patching)	
4.5 x mainline asphalt tonnage	
<b>Bituminous Patching of Concrete Pavement – Section 520</b>	
“Bituminous Patching” - Ton	
<b>Bituminous Sand Base Course – Section 509</b>	
“Bituminous Sand Base Course Asphaltic Oil” – Gallon	1000 Gal./Sta. for (5” x 24’)
“Bituminous Sand Base Course Emulsified Asphalt” – Gallon	1200 Gal./Sta. for (5” x 24’)
	6% residual
“Bituminous Sand Base Course” - Station	
“Mineral Filler for Bituminous Sand Base Course – Cubic Yard	**10 Cu Yds/Sta. for (5” x 24’)
	** Quantity of Mineral Filler will vary depending on type of soil.
“Mineral Aggregate” – Cubic Yard	Do not use for estimate
“Water” – MGallon	1 MGal/Sta.
“Fog Seal” – Gallon	0.15 Gal./yd <sup>2</sup>

**Exhibit 12.11 Estimating Quantities**

<b>Bituminous Surface Course – Section 512</b>	
“Bituminous Surface Course” – Square Yard	
“Fog Seal” – Gallon	0.6 Gal./yd <sup>2</sup>
<b>Bridge Items</b>	
“Placement of Asphaltic Concrete for Bridges” – SqYd or SqFt (begin w/8-25-22 letting)	
“Saw and Seal Joint” – LF – coming soon	
“Bridge Preparation” – SqYds or SqFt – Use Type 1 or 2	
“Preformed Waterproofing Membrane, Type 1” – SqYd	
“Preformed Waterproofing Membrane, Type 2” – SqYd	
“Preformed Waterproofing Membrane, Type 3” – SqYd – used for new bridges	
“Hot Liquid – Applied Membrane Waterproofing” – SqFt	
“Cold Liquid – Applied Membrane Waterproofing” – SqFt – item is no longer available, it may be in the future	
<b>Calcium Chloride, Applied – Section 309</b>	
“Calcium Chloride Applied” – Ton	3 lbs./yd <sup>2</sup>
<b>Cement Stabilized Bituminous – Special Provision</b>	
“Cement Stabilized Bituminous” - Station	
“Cement” – Ton	5% weight of RAP
“Water for Cement Stabilization” – MGallon	5% weight of RAP & Cement (convert to MGal)
“Cold Milling, Class 2” – Station	Use if required in the “Pavement Determination”
“Fog Seal” – Gallon (See Note)	0.24 Gal./yd <sup>2</sup>
Note: One application after the “CSB”, Second application after the “Cold Milling, Class 2” if required.	
<b>Chip Seal – Section 515</b>	
“Chip Seal Aggregate” – Cubic Yard	25 lbs./yd <sup>2</sup> (aggregate weight 1.4 tons = 1 yd <sup>3</sup> )
“Chip Seal Emulsified Asphalt” – Gallon	0.36 Gal./yd <sup>2</sup>
<b>Cold In-Place Recycling (W/Foamed Asphalt) – Special Provision</b>	
“Cold In-Place Recycling with Foamed Asphalt” - Station	
“Performance Graded Binder (58-28)” – Ton	2% RAP (4” x 24’ = 1.5 Tons/Sta.) (4” x 28’ = 1.34 Tons/Sta.)
“Fog Seal” – Gallon	0.10 Gal./yd <sup>2</sup>
<b>Cold Milling – Section 510</b>	
“Cold Milling, Class _____” – Station, Square Yard	
<b>Concrete Pavement Repair, Flexible Polymer Modified”</b>	
“Concrete Pavement Repair, Flexible Polymer Modified” – Square Yard	
Note: Special Provision describes depth of repair. Preparation of concrete, primer, bulking aggregate, and surfacing aggregate are subsidiary.	
<b>Concrete Sealer – Special Provision</b>	
“Penetrating Concrete Sealer” – Gallons	300 Square Feet per Gallon
<b>Concrete Surfacing Milling – Section 510</b>	
“Concrete Surface Milling” – Square Yard or Station	
<b>Cracking &amp; Seating Concrete Pavement – Special Provision</b>	
“Cracking & Seating” – Square Yard	
<b>Diamond Grinding and Texturing Pavement – Special Provision</b>	
“Diamond Grinding and Texturing Pavement” – Square Yard	
<b>Earth Shoulder Construction – Section 304</b>	
“Earth Shoulder Construction” – Station	<i>Shoulders are measured separately</i>
“Water” – MGallon	0.25 MGal/Sta.

Exhibit 12.11 Estimating Quantities



<p><b>Earth Shoulder Restoration – Special Provision</b>  <i>Use this item when the project has “Trenched Widening 1 ft.” and a 1-inch grade raise or less.</i>  <i>Use this item when the project has “Trenched Widening 3 ft.” and a 2-inch grade raise or less.</i>                      “Earth Shoulder Restoration – Station                      Shoulders are measured separately                      “Seeding, Type B” - Acre (Use 8’ wide x length) 1 Acre = 43,560 sq. ft.                      “Mulch” (Hay or Straw) – Ton                                      2.25 Tons/Acre</p>
<p><b>Fabric Reinforcement Crack Repair – Section 518</b>                      “Fabric Reinforcement Crack Repair” – Linear Feet (LF)</p>
<p><b>Fly Ash Stabilized – Special Provision</b>                      “Fly Ash Stabilized Bituminous” - Station                      “Fly Ash” – Ton    12% weight of RAP                      “Water for Fly Ash Stabilization” – MGallon                      5% weight of RAP &amp; Fly Ash                      “Cold Milling, Class 2” – Station                                      Use if required in the “Pavement Determination”                      Note: One application after the “FSAB”, Second application after the “Cold Milling, Class 2” if required.</p>
<p><b>Fog Seal – Section 513</b>                      “Fog Seal” – Gallon/CSS-1 &amp; CSS-1H                      Factor for mainline &amp; shoulder                                      0.12 Gal/yd<sup>2</sup>                      Factor for open graded friction course                                      0.16 Gal/yd<sup>2</sup>                      Factor for milled surface of Asph. Conc.                                      0.07 Gal/yd<sup>2</sup>                      Factor for milled surface of Bit. Sand                                      0.10 Gal/yd<sup>2</sup></p>
<p><b>Foundation Course – Section 307</b>                      “Foundation Course ____” – Square Yard                      Note: Use this item for estimates.  <i>Note: Foundation Course calculated as total pavement footprint including bevel. Water calculated for pavement footprint plus 3’ beyond. Plans show Foundation Course 3’ beyond pavement footprint.</i>                      “Bituminous Foundation Course ____” – Square yard                      In place weight for 4” + ¼” trimming = 123 lbs./ft<sup>3</sup> or 1.66 Ton/yd<sup>3</sup>                      Stockpiled Bituminous = 1.43 Ton/yd<sup>3</sup>                      “Crushed Concrete Foundation Course ____” – Square Yard                      In place weight for 4” + ¼” trimming = 0.19 Ton/yd<sup>2</sup>                      Stockpiled crushed concrete = 1.35 Ton/yd<sup>3</sup>                      Concrete Pavement in Place = [yd<sup>3</sup> x 1.94 Ton/yd<sup>3</sup> x 90% (10% loss)] = tons of crushed concrete available                      “Aggregate Foundation Course “D” ____” – Square Yard                      “Aggregate Foundation Course ____” – Square Yard or Ton                      In place weight for 4” + ¼” trimming = (yd<sup>2</sup> x 0.2222 Ton/yd<sup>2</sup>) = Tons</p>
<p><b>Gravel Embedment – Special Provision</b>                      “Gravel Embedment” - Station                      “Gravel” – Cubic Yard (Designer’s item)  <i>Note: Design is usually 2” gravel embedded in the upper 4” &amp; cap with 1”</i></p>
<p><b>Granular Subdrains – Section 915</b>                      “Granular Subdrains” - Each</p>
<p><b>High Friction Surface Treatment – Special Provision</b>                      “High Friction Surface Treatment (1-Layer)”                      Square Yard                      “High Friction Surface Treatment (2-Layer)”                      Square Yard</p>
<p><b>Hot In-Place Recycling – Special Provision</b>                      “Hot In-Place Recycling” - Station                      “Emulsified Asphalt for Hot In-Place Recycling” – Gal    1% of RAP                      (2” x 24’ = 69 Gal/Sta.) (2” x 28’ = 81 Gal/Sta.)</p>

Exhibit 12.11 Estimating Quantities

<b>Hydrated Lime Slurry Stabilization – Special Provision</b>	
“Hydrated Lime Slurry Stabilization” - Station	
“Hydrated Lime” – Ton	1.5% weight of RAP (4” x 24’ = 0.9 Tons/Sta.) (5” x 24’ = 1.1 Tons/Sta.)
“Emulsified Asphalt for HLSS” – Gal	1.75% weight of RAP & Lime (4” x 24’ = 245 Gal/Sta.) (5” x 24’ = 307 Gal/Sta.)
“Fog Seal” – Gallon	0.10 Gal/yd <sup>2</sup>
<i>Note: Growth factor Approx. ¾” for a depth of 3” to 5”. 1” for a depth of 6”.</i>	
<b>Intersections and Driveways – Section 302 &amp; Section 503</b>	
“Preparation of Intersections and Driveways” – Square Yards	
“Placement of Asphaltic Concrete for Intersections and Driveways” – Square Yards	
<i>Note: Asphaltic concrete paid for by roadway tonnage.</i>	
<b>Joint Sealing Asphalt to Concrete – Section 508</b>	
“Joint Sealing – Asphalt to Concrete” – Station (one side)	
<b>Mailbox Turnouts – Section 912 &amp; Special Provision</b>	
“Preparation of Intersections and Drives” – Square Yard	
“Placement of Drives and Intersections” – Square Yard	
<b>Microsurfacing – Section 514</b>	
“Microsurfacing Placement” - Station	
“Emulsified Asphalt for Microsurfacing” – Gallon	12% of total tons 240 Gal = 1 ton
“Aggregate for Microsurfacing” – Ton	83.8% of total tons
“Mineral Filler for Microsurfacing” – Ton	1.7% of total tons
<i>Note: Weight Factor is 6.6 Ton/100 ft<sup>3</sup></i>	
<i>Note: Lift thicknesses are ¼” and calculate rut depth if applicable.</i>	
<b>Milling Concrete for Inlays – Section 510</b>	
“Milling Concrete for Inlays” - Each	
<b>Non-Woven Pavement Overlay Fabric – Special Provision</b>	
“Non-Woven Pavement Overlay Fabric” – Square Yard	
<b>Performance Graded Binder (**-**) – Special Provision</b>	
Use EXHIBIT 12.12 to estimate the tons.	
<b>Perforated Pipe – Section 914</b>	
“_____ Perforated Pipe” – Linear Foot (LF)	
“_____ Non-Perforated Pipe” – Linear Foot (LF)	
<b>Removal and Processing of Concrete Pavement – Section 312</b>	
<b>Shoulder Subgrade Preparation – Section 302</b>	
“Shoulder Subgrade Preparation” - Station	
“Water” – MGallon	0.5 MGal/Sta.
<i>Note: Shoulders are measured separately</i>	
<b>Special Surface Course – Special Provision</b>	
<i>Note: Use this item if placing millings on driveways or under guardrail</i>	
“Special Surface Course” – Square Yard	
“Fog Seal” – Gallon	2 applications, 0.20 Gal/yd <sup>2</sup> for soil and 0.30 Gal/yd <sup>2</sup> for the surface

**Exhibit 12.11 Estimating Quantities**

<p><b>Stress Absorbing Fiberglass Layer with Emulsified Asphalt (SAFLEA)- Special Prov.</b>                  (Added item Summer 2017)                  "Stress Absorbing Fiberglass Layer with Emulsified Asphalt" – Square Yard                  "Armor Coat Emulsified Asphalt" – Gallon                      0.44 Gal/yd<sup>2</sup>                  "Armor Coat Aggregate" – Cubic Yard                      32 lbs./yd<sup>2</sup> (conversion factor 1.3 ton = 1 yd<sup>3</sup>)</p>
<p><b>Subgrade Preparation – Section 302</b>                  "Subgrade Preparation" – Station or Square Yard                  "Water" – MGallon    1.0 MGal/Sta. or 0.003 MGal/yd<sup>2</sup>  <i>Note: Subgrade Preparation calculated as total pavement footprint including bevel. Water calculated for pavement footprint plus 3' beyond. Plans show Subgrade Preparation 3' beyond pavement footprint.</i></p>
<p><b>Subgrade Preparation for Widening – Special Provision</b>  <i>Note: Use for concrete pavement widening</i>                  "Subgrade Preparation for Widening" – Station (one side)                  "Water" – MGallon    0.5 MGal/Sta.</p>
<p><b>Subgrade Stabilization – Section 303</b>                  "Subgrade Stabilization" – Station or Square Yard                  "Soil Binder" – Cubic Yard                                      12.5 yd<sup>3</sup>/Sta. (for 6" x 30")                  "Water" – MGallon    1 MGal/Sta. or 0.003 MGal/yd<sup>2</sup>  <i>Subgrade Stabilization calculated as total pavement footprint including bevel. Soil Binder and Water calculated for pavement footprint plus 3' beyond. Plans show Subgrade Stabilization 3' beyond pavement footprint.</i></p>
<p><b>Surfacing – Special Provision</b>                  "Surfacing " _____" – Square Yard  <i>Note: Contractor's choice for pavement type, asphaltic concrete or Portland Cement concrete.</i></p>
<p><b>Surfacing Under Guardrail – Special Provision</b>                  "Surfacing Under Guardrail" – Square Yard  <i>Note: Pay Item includes asphalt or concrete surface (contractor's option) and subgrade prep.</i></p>
<p><b>Stabilized Subgrade (8" Depth) – Special Provision</b>                  "Stabilized Subgrade Type Cement" – SY used if granular content is high for a variety of PIs                  "Cement" – Ton    27 lbs./yd<sup>2</sup> (cement quantity is **4% of soil tons)                  "Stabilized Subgrade Type Fly Ash" – Square Yard use if PI of soil is 19 or less                  "Fly Ash" – Ton    66 lbs./yd<sup>2</sup> (fly ash quantity is **10% of soil tons)                  "Stabilized Subgrade Type Lime" – Square Yard use if PI of soil is 20 or more                  "Hydrated Lime" – Ton    33 lbs./yd<sup>2</sup> (hydrated lime quantity is **5% of soil tons)                  "Water" – MGallon    1 MGal/Sta. or 0.003 MGal/yd<sup>2</sup>                  **Soil weight compacted in place, 110 lbs./ft<sup>3</sup>  <i>Note: Stabilized Subgrade Type _____ calculated as total pavement footprint including bevel. Cement, Fly Ash, Hydrated Lime, and Water calculated for pavement footprint plus 3' beyond. Plans show Stabilized Subgrade Type " _____" 3' beyond pavement footprint.</i></p>
<p><b>Tack Coat - Section 504</b>                  "Tack Coat" – Gallon                  Factor for existing surface                                      0.15 Gal/yd<sup>2</sup>                  Factor for between lifts    0.05 Gal/yd<sup>2</sup></p>
<p><b>Temporary Surfacing – Special Provision</b>                  "Temporary Surfacing " _____" – Station or Square Yard  <i>Note: Contractor's choice for pavement type, asphaltic concrete or Portland Cement concrete.</i>  <i>Note: Subgrade Preparation, earth shoulder construction, water applied, and removal are subsidiary.</i></p>

Exhibit 12.11 Estimating Quantities

<b>Trenched Widening 1' – Special Provision</b> “Trenched Widening 1’ ” – Station Note: Include “Earth Shoulder Construction” or “Earth Shoulder Restoration”	<i>Measured separately – one side</i>
<b>Trenched Widening 3' – Special Provision</b> “Trenched Widening 3’ ” – Station Note: Include “Earth Shoulder Construction” or “Earth Shoulder Restoration”	<i>Measured separately – one side</i>
<b>Widening – Special Provision</b> “Widening” – Station	<i>Measured separately</i>
<b>Ultra Thin Bonded Asphalt Wearing Course – Special Provision</b> “Ultra Thin Bonded Asphalt Wearing Course” - Ton “Performance Graded Binder **_** - Ton “UTBAWC” will be SLX, SPR (Fine) or SPH (0.375) as noted in the “Pavement Determination” <i>Note: Do not pay for Tack Coat</i>	

**Exhibit 12.11 Estimating Quantities**

Performance Graded Binder (**-**) Table					
Min – Max Rap Section 1028.02	Asph. Conc. Type	PG Binder (**-**) Type	Gradation Bands (0.5) multiply Asph. Conc. Tonnage by	Gradation Bands (0.375) multiply Asph. Conc. Tonnage by	Gradation Bands (0.19) multiply Asph. Conc. Tonnage by
	GGCRM	Check with Bob Rea	8.5%	NA	NA
	GGCRMLV	Check With Bob Rea	8.5%	NA	NA
25%	LC	(58H-34)	NA	NA	5.2%
20% - 35%	SLX	(58H-34)	NA	4.2%	NA
20% - 35%	SLX for I-State	(58V-34)	NA	4.2%	NA
0% - 50%	SPR	(58H-34)	3.4%	NA	NA
0% - 55%	SPR (Fine)	(58H-34)	NA	3.4%	NA
0% - 65%	SPS	(58S-34)	3.2%	NA	NA
0% - 25%	SPH	(58H-34)	3.8%	3.8%	NA
0% - 65%	SRM	(58H-34)	2.8%	NA	NA

From Bob Rea September 2020 Virgin Mix use 5.8% for SLX, 5.4% for SPR and 5.4% for SPS

1" SLX thin lifts – add 15% to asphalt tons for slope and profile correction.

**Exhibit 12.12 Performance Graded Binder Table**

Hydrated Lime/Warm Mix Asphalt	
Asph. Conc. Type	"Hydrated Lime/WMA" Pay item is "Each" multiply tons of asphalt by
GGCRM	1
GGCRNLV	1
LC	1
SLX	1
SPR	1
SPR (Fine)	1
SPS	NA
SPH	1
SRM	1

Example: If you have 10,534 tons of Asphaltic Concrete Type "SPR", there will be 10,534 Each of "Hydrated Lime/WMA"

**Exhibit 12.13 Hydrated Lime/Warm Mix Asphalt**

### Asphaltic Concrete Tonnage Table Asphaltic Concrete Types

	Bit Sand Base Crse	Bit Fnd Crse	OGFCCRMM	GGCRM	GGCRMLV	LC	SLX	SPS SPH	SPR (Fine) SPR SRM	
	<b>Tons per 100 Cubic Feet</b>									
	6.0	6.2	6.3	6.75	6.95	7.15	7.25	7.30	7.35	7.40
	<b>Pounds per Cubic Foot</b>									
	120	124	126	135	139	143	145	146	147	148
	<b>Tons/SqYd/Inch</b>									
<b>Inches</b>										
<b>1</b>	<u>0.045</u>	<u>0.050</u>	<u>0.050</u>	<u>0.051</u>	<u>0.052</u>	<u>0.054</u>	<u>0.054</u>	<u>0.055</u>	<u>0.055</u>	<u>0.055</u>
<b>1.5</b>										
<b>2</b>	<u>0.090</u>	<u>0.093</u>	<u>0.095</u>	<u>0.101</u>	<u>0.104</u>	<u>0.107</u>	<u>0.109</u>	<u>0.110</u>	<u>0.110</u>	<u>0.111</u>
<b>2.5</b>										
<b>3</b>	<u>0.135</u>	<u>0.140</u>	<u>0.141</u>	<u>0.151</u>	<u>0.156</u>	<u>0.161</u>	<u>0.163</u>	<u>0.164</u>	<u>0.165</u>	<u>0.166</u>
<b>3.5</b>										
<b>4</b>	<u>0.180</u>	<u>0.186</u>	<u>0.189</u>	<u>0.202</u>	<u>0.208</u>	<u>0.214</u>	<u>0.218</u>	<u>0.219</u>	<u>0.221</u>	<u>0.222</u>
<b>4.5</b>										
<b>5</b>	<u>0.225</u>	<u>0.233</u>	<u>0.236</u>	<u>0.253</u>	<u>0.260</u>	<u>0.268</u>	<u>0.272</u>	<u>0.274</u>	<u>0.276</u>	<u>0.278</u>
<b>5.5</b>										
<b>6</b>	<u>0.270</u>	<u>0.279</u>	<u>0.284</u>	<u>0.303</u>	<u>0.313</u>	<u>0.322</u>	<u>0.326</u>	<u>0.329</u>	<u>0.331</u>	<u>0.333</u>
<b>6.5</b>										
<b>7</b>	<u>0.315</u>	<u>0.326</u>	<u>0.331</u>	<u>0.354</u>	<u>0.365</u>	<u>0.375</u>	<u>0.381</u>	<u>0.383</u>	<u>0.386</u>	<u>0.388</u>
<b>8</b>	<u>0.360</u>	<u>0.372</u>	<u>0.378</u>	<u>0.405</u>	<u>0.417</u>	<u>0.429</u>	<u>0.435</u>	<u>0.438</u>	<u>0.441</u>	<u>0.444</u>
<b>9</b>	<u>0.405</u>	<u>0.419</u>	<u>0.425</u>	<u>0.456</u>	<u>0.469</u>	<u>0.483</u>	<u>0.489</u>	<u>0.493</u>	<u>0.496</u>	<u>0.500</u>
<b>10</b>	<u>0.450</u>	<u>0.465</u>	<u>0.473</u>	<u>0.506</u>	<u>0.521</u>	<u>0.536</u>	<u>0.544</u>	<u>0.548</u>	<u>0.551</u>	<u>0.555</u>

**Exhibit 12.14 Asphaltic Concrete Tonnage Table**

## 10. REFERENCES

- 12.1 Nebraska Department of Transportation, Right-of-Way Manual, Current Edition.  
(<https://dot.nebraska.gov/media/0sopjmah/row-manual.pdf>)
- 12.2 Nebraska Department of Transportation, Design Process Outline (DPO), Current Edition.  
(<https://dot.nebraska.gov/business-center/design-consultant/>)
- 12.3 Nebraska Department of Transportation, Standard Specifications for Highway Construction (Spec Book), 2017.  
(<https://dot.nebraska.gov/media/g4qp4y0d/2017-specbook.pdf>)
- 12.4 Nebraska Department of Transportation, Drainage Design and Erosion Control Manual (Drainage Manual), Current Edition.  
(<https://dot.nebraska.gov/business-center/design-consultant/rd-manuals/>)





The information contained in Chapter Thirteen: Planning and Project Development, dated May 2022, has been updated to reflect the October 2023 Errata. The errata addresses errors, changes in procedure, changes in NDOT department titles, changes in other Roadway Design Manual chapters and other reference material citations occurring since the latest publication of this chapter.

Chapter Thirteen presents guidance for the design of New, Reconstructed and 3R projects: additional design guidance for 3R projects is provided in Chapter Seventeen.

# Chapter Thirteen

## Planning and Project Development

### 1. INTRODUCTION AND GENERAL CONSIDERATIONS

Prior to the preliminary design stage, a roadway project goes through extensive planning, analysis, and evaluation to assure that the **Nebraska Department of Transportation (NDOT)** provides improvements when and where they are most needed. Among the many factors that are considered during the planning and project development stages are:

- Traffic counts and forecast evaluation.
- Needs study criteria evaluation.
- Environmental effects of the project.
- Public participation and input into the project.
- Social and economic effects of the project.
- Alternative courses of action.

The **Materials and Research Division (M&R)**, the **Strategic Planning Division**, the **Project Development Division (PDD)** and the **Project Scheduling Section of the Program Management Division** are responsible for the planning and project development processes and for liaison with other agencies and organizations that are involved in a project. The **Communications Division** coordinates the public meetings and hearings that are part of the process.

## 2. PLANNING AND SCHEDULING

- The **M&R Classification, Needs, and Pavement Management Unit** performs ongoing data collection, analysis, prioritization and evaluation involving roadway inventories, pavement condition, traffic forecasts, demographic and economic information.
- The **Project Scheduling Section of the Program Management Division** plans and programs highway improvements and then manages Clarity, which programs, schedules and monitors projects through preconstruction stages.
- The **Project Scheduling Section of the Program Management Division** develops One Year Programs and Five Year and Beyond Programs.

The factors noted in Section 1 are used to develop the highway plan for non-metropolitan areas. In metropolitan areas such as Omaha, Lincoln, and South Sioux City, transportation planning is part of the continuing, cooperative and comprehensive (3C) planning process performed by metropolitan planning organizations (MPOs) consisting of state and local government officials and citizen representatives. Transportation modeling in urban areas consists of trip generation, distribution, assignment and modal split models that forecast system needs.

## 3. ENGINEERING REVIEW AND LOCATION STUDIES

### 3.A Engineering Review

Once a project has been initiated with a “Highway Improvement Programming Request”, NDOT Form 73, but before it has been approved, the scope of the project and the initial cost estimate (Status 05) are determined (See Chapter Twelve: Cost Estimating & Funding, Section 3.B, of this manual).

After the NDOT Form 73 has been approved, the **PDD Project Scoping Section** conducts an engineering review. Engineering review is a process performed very early in the development of a project to establish the concept of work to be performed and the initial itemized cost estimate for the project (Status 10) (See Chapter Twelve: Cost Estimating & Funding, Section 4, of this manual). Engineering reviews are generally performed for major, non-Interstate projects such as resurfacing, major bridge work, reconstruction, relocation, etc. Usually an engineering review is not performed for safety projects, traffic signal projects or other minor engineering projects.

The engineering review summarizes the existing highway condition, pavement condition, traffic volumes, and highway classification and includes a description of the existing typical roadway section and of adjacent roadway sections. It outlines or describes the horizontal and vertical alignment geometrics. The engineering review includes a listing of any structures within the proposed project limits and their condition. It also includes a listing of historical bridges, wetland involvement, underground fuel tanks, hazardous waste locations, safety history, railroad involvement, utilities, etc.

**PDD** then reviews the existing conditions, confers with the **District Engineer (DE)** and other engineers, reviews the photolog or visits the site, if necessary, and decides upon a recommendation for the type of project to be undertaken. The engineering review and its recommendations then are circulated to the **Roadway Design Engineer**, the **DE** and the **Deputy Director-Engineering** for their approval.

The engineering review provides a starting point and direction for the roadway designer. The designer must use it as a guideline but has the option of making significant scope modifications, with proper documentation and approval, as more information becomes available.

From the engineering review, the **Project Scoping Section** of **PDD** prepares a Scoping Document containing project data, a brief description of the proposed work and a recommendation as to the environmental classification of the proposed project, (See Section 4 of this chapter). This form is submitted to the **Federal Highway Administration (FHWA)** for review, comments, and concurrence in the environmental classification. Once **FHWA** environmental classification concurrence is obtained, preliminary design may proceed.

### **3.B**      **Location Studies**

Location studies are conducted to address social, economic, environmental and other issues associated with alternative project locations. Location studies may be conducted for specific "spot" locations, such as new bridge crossings of the Missouri River, or for longer corridors.

Corridor study projects often involve some relocation and some community bypasses. Corridor study results are published in report form. Contents of a corridor report include information similar to that in an engineering review, e.g., alignment location factors, cost estimates, etc. They may include Plan and Profile Sheets developed from as built plans or **U.S. Geological Survey (USGS)** contour maps.

Location studies usually take from eighteen months to two years to complete. Public information meetings and a location public hearing are usually part of the study. Location studies are also circulated among various **NDOT** divisions for comment and input. Projects on new location are normally taken to the **State Highway Commission** and the **Governor** for location approval shortly after the location hearing.

#### 4. PROJECT COORDINATION MEETINGS

Project Coordination Meetings (PCMs) are used to communicate project details between different **Divisions/Districts** within **NDOT**. The importance of these meetings is to establish impacts and threshold levels early in the project to alleviate schedule changes and project delays. For more information on the threshold levels, refer to the Environmental Procedure Manual (<https://dot.nebraska.gov/projects/environment/environmental-guidance-library/>)

The PCMs will be scheduled and documented by the **PCM Coordinator** in the **PDD Environmental Project Management Unit (EPMU)**, except for PCM 30 which is scheduled by the **Roadway Design Designer/Engineer**. Four of the five meetings listed below are required for each project unless a determination is made that states a specific PCM is not required. PCM 50 is optional, the applicability of the meeting will be determined at PCM 35. If the time frame between PCM 35 and PCM 70 will likely exceed more than one year, and/or the project requires right-of-way, then it may be determined that the PCM 50 is necessary. The meetings and their occurrence throughout the life of a project is shown in EXHIBIT 13.1 as follows:

- PCM 20 – End of Phase 2, during the Planning Phase.
- PCM 30 – Beginning of Phase 3, during the Design Phase.
- PCM 35 – End of Phase 3, during the Design Phase.
- PCM 50 – End of Phase 3, prior to completion of the National Environmental Policy Act (NEPA) document (See Section 5 of this chapter). Applicability will be determined at PCM 35.
- PCM 70 – Within Phase 7, during the Plans Package Phase.

The meetings will be scheduled as requested, based on the Clarity schedule date and the status of project tasks. If **Roadway Design** would like to schedule an earlier meeting, they can request that meeting through the **PDD PCM Coordinator** in **EPMU** based on whether the needed information has been collected and/or completed. A meeting notice and the project schedule will be sent out approximately three business days in advance of the meeting. The meetings will be held weekly on Mondays of each month between 1:00 PM and 4:00 PM, the schedule will be adjusted accordingly around various holidays occurring on those days. Meetings may be scheduled weekly in order to meet demand of requests. Projects are likely to have separate meetings outside of the PCMs that will bring important stakeholders together to discuss in further detail environmental issues related to the project.

The PCM checklists and forms are shown in Appendix K, “Project Coordination Meetings”, of this manual. The list of “Information Needed and has been Completed/Collected” is a checklist to be utilized by **Roadway Design** showing that the required information has been completed prior to attending the PCM. **Roadway Design** and **PDD Environmental Project Manager** in **EPMU** should also be responsible for notifying stakeholders when missing items of information are required for the upcoming meeting.

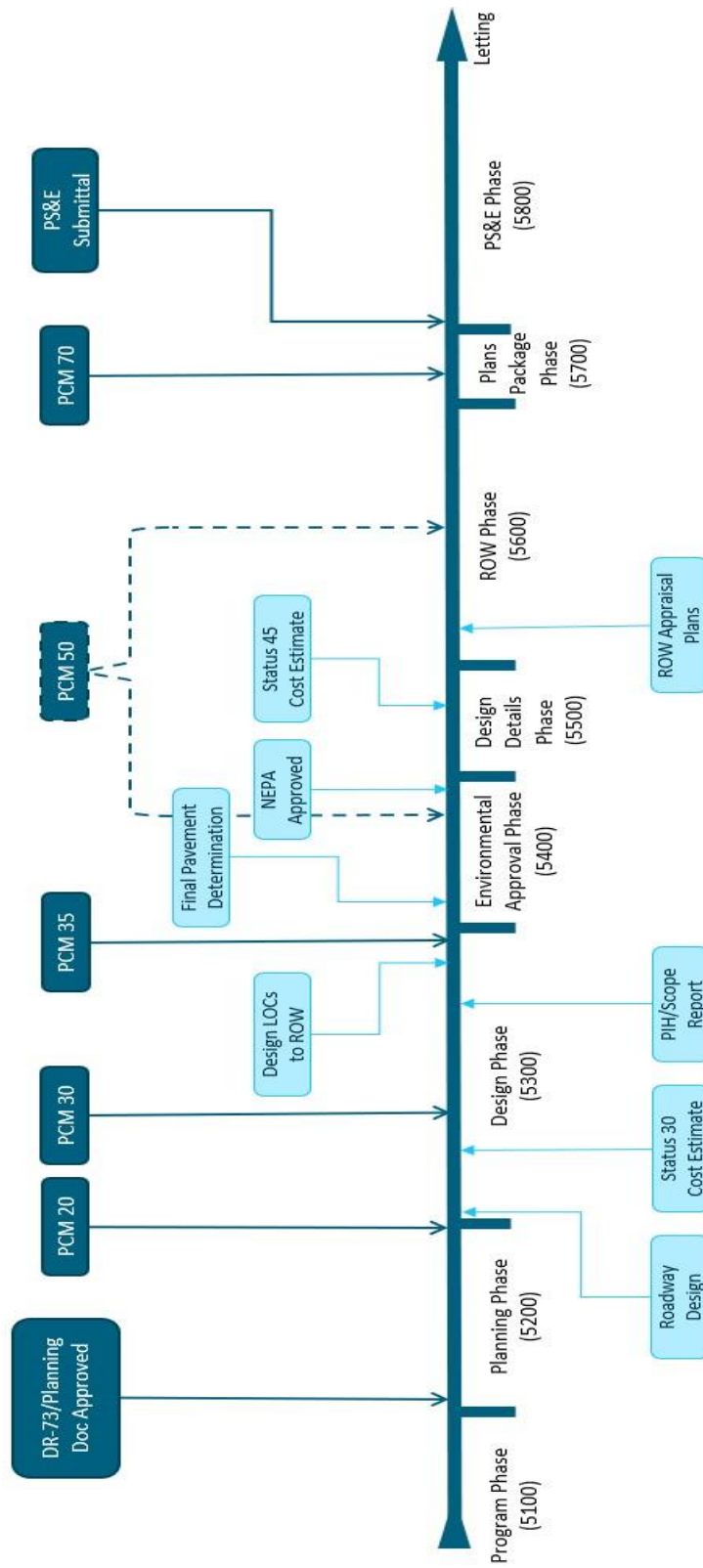


Exhibit 13.1 Project Coordination Meeting Timeline

## 5. ENVIRONMENTAL STUDIES

### 5.A. Environmental Classification and Documentation

The National Environmental Policy Act (NEPA) (Ref. 13.1), (<https://ceq.doe.gov/>), specifies that all federal agencies, including **FHWA**, must protect the environment through their policies, goals and actions. **PDD** is responsible for the required research, documentation and applications for approvals and permits.

Roadway design should be coordinated with environmental impact mitigation measures. If the designer encounters potential problems during design, e.g., learns of the possible presence of an endangered species, underground fuel tank, electrical substation, wetland, channel relocation, etc., he/she should contact the **Environmental Section Manager** of **PDD**.

#### 5.A.1 Environmental Classification

Federal regulations divide all projects into three classes, depending on their potential for impacting the environment. The three classes are:

- A. Class I Projects may significantly affect the environment and require preparation of an environmental impact statement (EIS), and the issuance of a Record of Decision (ROD) by **FHWA**. Basically, new four-lane construction on new location or projects with a significant environmental impact will be Class I projects.

When **FHWA** concurs that a project is a Class I project, **PDD** conducts a social, economic and environmental review (SEE). Issues of significant impact and possible alternatives are identified. Appropriate federal, state and local agencies are contacted for coordination and comments throughout the development of the project.

- B. Class II Projects, based on past experience, do not have a significant effect on the environment. These will include projects such as overlays, bridge replacement, lighting and various other projects with no significant impact. Class II projects, identified as categorical exclusions (CE), are divided into two groups:
  - Group 1 CE - normally do not require NEPA documentation or **FHWA** approval as a CE.
  - Group 2 CE - normally do require minimal environmental documentation and **FHWA** approval of the proposed CE.
- C. Class III Projects are projects on which the significance of the effect on the environment must be determined. Class III projects require the preparation of an environmental assessment (EA) and result in a finding of no significant impact (FONSI). Class III projects that find possible significant impact are reclassified as Class I.

### 5.A.2 4(f) Evaluation (Publicly Owned Lands/Historic Places)

Section 4(f) of the 1966 Transportation Act (Ref. 13.3), (<https://www.environment.fhwa.dot.gov/legislation/section4f.aspx>) applies to **U.S. Department of Transportation (USDOT)** agencies and projects. It limits use of the following publicly owned lands:

- public parks.
- recreation areas.
- wildlife/waterfowl refuges.
- lands having historic sites of national, state or local significance.

These lands are known as 4(f) lands.

**FHWA** may not approve use of 4(f) lands for roadway improvements unless *“no feasible and prudent alternative is possible and all possible planning has been done to minimize harm”*. Among the impacts that are considered in 4(f) evaluations are: amount of land to be used for the project, facilities and functions affected, noise/air pollution, visual impact, etc. The designer must contact the **EDU** if any of the above listed facilities may be impacted by the project.

### 5.A.3 6(f) Lands (Land Water Conservation Funds Used For Park Improvements)

In addition to 4(f) documentation, **PDD** must also determine if any improvements to the public park lands were funded with monies from Section 6(f) of the Land Water Conservation Fund Act (Ref. 13.4), ([https://www.environment.fhwa.dot.gov/env\\_topics/4f\\_tutorial/related.aspx](https://www.environment.fhwa.dot.gov/env_topics/4f_tutorial/related.aspx)), administered by the **National Park Service**. Use of areas improved with 6(f) funds for roadway projects will require coordination with the **National Park Service** and possible replacement of any lands used for the roadway project. Contact the **EDU** to determine if 6(f) lands are present on the project. If 6(f) lands are present, the designer should attempt to avoid impacting them, minimize the impact if avoidance is not possible, and/or mitigate the impact.

## 5.B Wetlands and Section 404 Permits

Under Section 404 of the Clean Water Act, (Ref. 13.5), (<https://www.epa.gov/cwa-404/section-404-permit-program>), and under Title 117 of the Nebraska Surface Water Quality Standards, (<http://www.deg.state.ne.us/NDEQProg.nsf/SearchWeb.xsp?search=nebraska%20surfae%20water%20quality%20standards>), impacts to wetlands are to be avoided if possible, minimized if avoidance is not possible, and/or mitigated.

### 5.B.1 Wetlands Definitions

The **U.S. Army Corps of Engineers (Corps of Engineers)** and the **U.S. Environmental Protection Agency (EPA)** define wetlands as follows:

*“Those areas that are inundated or saturated by surface or groundwater at a frequency and duration sufficient to support, and that under normal circumstances do support, a prevalence of vegetation typically adapted for life in saturated soil conditions.”*

Wetlands generally include swamps, marshes, bogs and similar areas.

Wetland determination is based upon an evaluation of soil type, hydrology and plants that live in the area. Situations that suggest that a wetland determination should be made include:

- Area is in a floodplain or otherwise has low spots in which water stands at or above the soil surface during the growing season (however, most wetlands lack both standing water and waterlogged soils during at least part of the growing season).
- Area has plant communities that commonly occur in areas having standing water for part of the growing season.
- Area has soils that are peats or mucks.
- Area is designated on a National Wetlands Inventory Map as being a wetland (<https://www.fws.gov/wetlands/Data/Mapper.html>)

### 5.B.2 Wetlands Procedures

A primary goal of roadway design is to avoid wetlands as much as practicable. If this is not possible, then wetlands encroachment should be minimized. Mitigation for wetland encroachment may be required. Wetlands are replaced at a minimum rate of 1:1 or more. If any work is planned in or near a river, stream, pond or wetland, contact the **Environmental Permits Unit (EPU)** in **PDD** as early as possible during project planning. The following procedures should be followed to coordinate roadway design, wetland delineation and wetland mitigation design.

1. During engineering review, the **Wetlands Biologists** will inspect the project site and delineate the wetlands on Aerial Sheets (See Chapter Eleven: Highway Plans Assembly, Section 4.E, of this manual).
2. **EPU** drafts the wetland delineation on CAD and sends the CAD file and Waterway Permit Data Sheet (NDOT Form 290) to the roadway designer. This permit data sheet covers waterway permit information, historic bridges and other environmental issues.
3. The designer will use the Aerial Sheets and his/her cross-sections to calculate the areas in acres of impacted wetland for each type of wetland as delineated on the Aerial Sheets (See NDOT Form 290).



4. At the plan-in-hand, the impact on wetlands will be discussed and alternative designs may be considered.
5. After the plan-in-hand changes, if any, have been incorporated into the project the designer completes the Waterway Permit Data Sheet (NDOT Form 290) using the limits of construction. The completed Aerial Sheets, with the limits of construction, and Waterway Permit Data Sheet (NDOT Form 290) will be returned to **EPU** for preparation of the waterway permit applications.
6. If mitigation is required for a project the roadway designer and the **EPU Manager** will study alternate mitigation sites and select the proper mitigation site prior to the public hearing dry run.
7. **EPU** will review the information and will send mitigation requirements, suggested mitigation sites, reconstruction sites, etc. to the designer. The designer will make final site decisions based on this information, present land use and other engineering considerations.
  - When possible, only one mitigation site should be shown on the public hearing plans.
  - When no apparent suitable mitigation site is available, public hearing plans should not show any wetland mitigation sites.
  - If mitigation will be accomplished at a wetland mitigation bank site, the bank's name and legal description should be stated at the public hearing.
8. If mitigation is required along the project, the roadway designer designs the mitigation site area with wetland design parameters from **EPU** before the public hearing.
9. After considering public hearing inputs, the final mitigation site design is incorporated into the project plans.
10. Once the mitigation area is designed, the **Roadway Design Division (Roadway)** sends the Plan and Profile Sheets and the cross-sections to **EPU** for further processing.
  - Mitigation areas should be noted on the profile and on the cross-sections to assure that areas specifically designed not to drain are not changed during construction.
11. **EPU** then develops and sends to the designer an environmental summary sheet (EXHIBIT 13.2) that includes threatened and endangered species, specifications, special provisions, conditions, copies of the applicable permits and instructions on additional plans needed and aerials to be included in the final plans. **EPU** will also send this package to other concerned parties.
12. The roadway designer will provide the necessary pay item quantities, plans, cross-sections and other relevant information for the plans, specifications and estimates (PS&E) package.
13. The **EPU Manager** will provide the Aerial Sheets delineating wetlands both on and off the project, special provisions and the permit documents with conditions for the PS&E package.

Deeds for land acquired for wetlands mitigation shall be written specifying the reason for the acquisition to forestall selling this land in the future. It is the responsibility of the roadway designer to inform the **Right-Of-Way Design Division (ROW Design)** when, and what, land is being acquired for wetlands mitigation.

Project No.:  
 Control No.:  
 Location:

**SPECIAL ENVIRONMENTAL CONDITIONS  
 PROJECT DEVELOPMENT SUMMARY SHEET**

**WATERWAY PERMITS**

	<u>Type of Permit</u>	<u>Location</u>	<u>Permit Number</u>
Sample	Nationwide #14 Floodplain Permit	between Section 13+24, T2N-R23W Section 13+24 T2N-R23W	NE 99-11158

Special Plans (to be included in PS&E plan package):

- |                        |                              |                             |
|------------------------|------------------------------|-----------------------------|
| Aerial Sheets          | <input type="checkbox"/> Yes | <input type="checkbox"/> No |
| Mitigation Plan        | <input type="checkbox"/> Yes | <input type="checkbox"/> No |
| Special Cross-Sections | <input type="checkbox"/> Yes | <input type="checkbox"/> No |
| Others                 | <input type="checkbox"/> Yes | <input type="checkbox"/> No |

Special notes on plans:

None

Special provisions (See Attached):

See Attachment A: Fact sheet for a Nationwide #14 permit.

Special conditions (See Attached):

See Attachment B: The Corps of Engineers Authorization.

Additional comments:

See Attachment C: Floodplain permit from \_\_\_\_\_ City/County.

This project was delineated for the presence of wetlands on \_\_\_\_\_. Mandatory criteria, as defined in the 1987 Corps of Engineers Wetlands Delineation Manual, were used for wetland determinations. These findings were based on hydric soil, wetland plant, and wetland hydrology information gathered during this on-site evaluation.

\_\_\_\_\_  
 Environmental Permits Unit Manager (Signature & Date)

Project No.:  
Control No.:  
Location:

**HISTORIC SITES**

Historic bridges       Yes       No

Special provisions (See Attached):

Additional comments:

---

Environmental Section Manager *(Signature & Date)*

**OTHER ENVIRONMENT ISSUES**

Special conditions:

Special notes on plans:

Additional comments:

---

Environmental Section Manager *(Signature & Date)*

### 5.B.3 Public Notification of Wetland Mitigation

It is **NDOT's** intent to make the public aware of wetland issues as early in the life of a project as is feasible. To that end **NDOT** has adopted the following policy regarding public notification of wetland mitigation:

#### A. Public information meetings held for Engineering Reviews or Location Studies

1. A preliminary determination of wetlands will be done on aerial photos for use in the development of alternative concepts.
2. Information about the anticipated impact to wetlands will be made available to the public, either on handout material or on the displays. The wetland impact will be described as either major (more than three acres) or minor (less than three acres).

#### B. Major projects on new alignments that have a corridor study and hearing.

1. Location Hearing
  - a. The **Location Studies Engineer** provides avoidance analysis and preliminary estimate of wetland impacts to **EPU**.
  - b. The **EPU Biologist** returns the required mitigation area and potential mitigation sites.
  - c. At the location hearing, existing wetlands and potential mitigation sites that are truly feasible are shown.
2. Before Plan-In-Hand
  - a. The designer sends updated wetland impacts, based on limits of construction, to **EPU** (four weeks prior to plan-in-hand). Include revised avoidance analysis if impacted wetlands are different from corridor study.
  - b. The **EPU Biologist** sends the designer updated mitigation areas and prioritized mitigation sites.
3. During Plan-In-Hand
  - a. The preferred mitigation site is decided upon.
4. After Plan-In-Hand
  - a. The designer notifies **EPU** of the preferred mitigation site and continues design. (Include in plan-in-hand report.)
5. Design Hearing
  - a. The preferred mitigation site is shown.
  - b. Show existing wetlands and other alternate mitigation sites, if they are truly feasible.
  - c. The public hearing notice will include a location map with preferred site and other potential sites shown.

#### C. Design Hearing Held and Corridor Hearing Not Held

1. Before Plan-In-Hand
  - a. For a project with proposed new alignments, the designer sends avoidance analysis and estimated wetland impact based on limits of construction, to **EPU**. (four weeks prior to plan-in-hand.)
  - b. The **EPU Biologist** sends the designer required mitigation areas and prioritized mitigation sites.
2. During Plan-In-Hand
  - a. The preferred mitigation site is decided upon.

3. After Plan-In-Hand
    - b. The designer notifies **EPU** of the preferred mitigation site and continues design. (Include in plan-in-hand.)
  4. Design Hearing
    - a. The preferred mitigation site is shown.
    - b. Show existing wetlands and other alternate mitigation sites, if they were truly feasible.
    - c. The public hearing notice will include a location map with preferred site and other potential sites shown.
- D. Design Hearing Not Held and Three Acres or More Mitigation Required
1. Before Plan-In-Hand
    - a. The designer sends avoidance analysis and estimated wetland impacts, based on limits of construction, to **EPU**. (four weeks prior to plan-in- hand.)
  2. During Plan-In-Hand
    - a. The preferred mitigation site is decided upon.
  3. After Plan-In-Hand
    - a. The designer notifies **EPU** of the preferred mitigation site and continues design (Include in plan-in-hand report.)
  4. Hold Wetlands Information Meeting
    - a. The preferred mitigation site is shown.
    - b. Show existing wetlands and other alternate mitigation sites, if they were truly feasible.
    - c. The public information meeting notice will include a location map with preferred site and other potential sites shown.
- E. Design Hearing Not Held and Less Than Three Acres of Mitigation Required
1. Before Plan-In-Hand
    - a. The designer sends avoidance analysis and estimated wetland impacts, based on limits of construction, to **EPU**. (four weeks prior to plan-in- hand.)
    - b. The **EPU Biologist** sends the designer the required mitigation area and prioritized mitigation sites.
  2. During Plan-In-Hand
    - a. The preferred mitigation site is decided upon.
  3. After Plan-In-Hand
    - a. The designer notifies **EPU** of the preferred mitigation site and continues designing. (Include in plan-in-hand report.)
    - b. A location map with the preferred site and other potential sites will be sent to local newspapers with a note that **NDOT** will be mitigating the loss of wetlands due to the construction of pending Project No. \_\_\_\_\_.  
For more information contact \_\_\_\_\_.
- F. If wetland mitigation is handled by taking credit from a wetland bank, specific wetland information meetings are not necessary.

#### 5.B.4 Section 404 Permits

Section 404 of the Clean Water Act (Ref. 13.5) requires that anyone interested in depositing dredged or fill material into waters of the United States, including wetlands, must receive authorization for such activities through permitting from the **Corps of Engineers**. Activities in wetlands for which permits may be required include: placement of fill material, ditching activities, levee and dike construction, mechanized land clearing, land leveling, most road construction and dam construction.

The **Corps of Engineers** issues three types of permits: individual, regional and nationwide (NWP) general permits. An individual permit is required when a project is not exempted from regulation and is of a scope and magnitude that it does not fall under the other two categories. Regional and nationwide permits are issued for projects that have minimal environmental impacts. In evaluating a permit application, the **Corps of Engineers** analyzes the following factors:

- Conservation
- Economics
- Aesthetics
- General environmental concerns
- Historic values
- Fish and wildlife values
- Flood damage prevention
- Land use, navigation
- Recreation
- Water supply and water quality
- The needs and welfare of the people

For an individual permit on new alignments, the **Corps of Engineers** will require alternatives analysis. Impacts for alternate alignments must be calculated and retained in the project file by the designer. Required alternatives analysis includes:

- What was done to avoid wetlands impacts?
- What was done to minimize wetlands impacts?

Erosion control is a condition of the Section 404 permit, (See Chapter Two: Erosion and Sediment Control of the Drainage Design and Erosion Control Manual, Ref. 13.6) (<https://dot.nebraska.gov/media/ajjpyh3d/e-chap-2-erosion-control.pdf>). Plans must include control of water (and siltation due to runoff) into any water body including wetlands. **PDD** will identify any location where roadway runoff or other non-point source pollution may adversely impact sensitive water resources such as water supply reservoirs, ground water recharge areas, high quality streams and threatened and endangered aquatic species. **PDD** submits the necessary applications for Section 404 permits.

### 5.B.5 Section 10 of the Rivers and Harbors Act

Structures or work affecting navigable waters of the U.S. are regulated under Section 10 of the Rivers and Harbors Act of 1899 as amended (Ref. 13.7), (<https://www.epa.gov/cwa-404/section-10-rivers-and-harbors-appropriation-act-1899>). In Nebraska, only the Missouri River is considered a navigable river. If required, **EPU** will obtain a Section 10 permit from the **Corps of Engineers**.

### 5.B.6 Channel Changes

When a channel change is required to meet project objectives, site conditions should be evaluated early in the design process. Channel width and length, vegetation, ponding, existing erosion control measures, etc. should be noted and the new channel should be designed so as to equal or better these conditions. **EPU** should be notified of the proposed channel change as soon as possible in order to determine mitigation, special conditions, and to get the necessary outside agencies involved at the beginning of the project. This will benefit **NDOT** in the permitting process.

The **Nebraska Department of Environmental Quality (NDEQ)** and the **Corps of Engineers** typically requires the following conditions for channel changes for Nationwide (404) Permits:

1. A 50 foot minimum width buffer strip of native vegetation on each side of the channel, starting at the top of the bank and measuring outward.
2. In some cases 2:1 tree and shrub replacement, planted in the buffer strip.
3. Construction of a channel wide enough so that the new stream bottom area is equal to or greater than that of the channel to be filled and the cross-sectional area of the new channel is equal to or greater than that of the old channel.
4. New channel banks should be sloped no steeper than 1:3, (1:2 if certified by an engineer).
5. Channel length shall be equal to or greater than that of the channel to be filled if the total channel length is less than 100 feet (net loss).
6. No more than 300 feet of channel can be impacted.

If these conditions cannot be met, meet with the **EPU Manager** as soon as possible because an individual 404 permit will be required, increasing the time required for the permit process.

The **Corps of Engineers** also requires that any channel change designed without a grade control structure must have a registered engineer verify, in writing, that a grade control structure is not required. The following example statement has been accepted by **PDD** and by the **Corps of Engineers** as fulfilling this requirement:

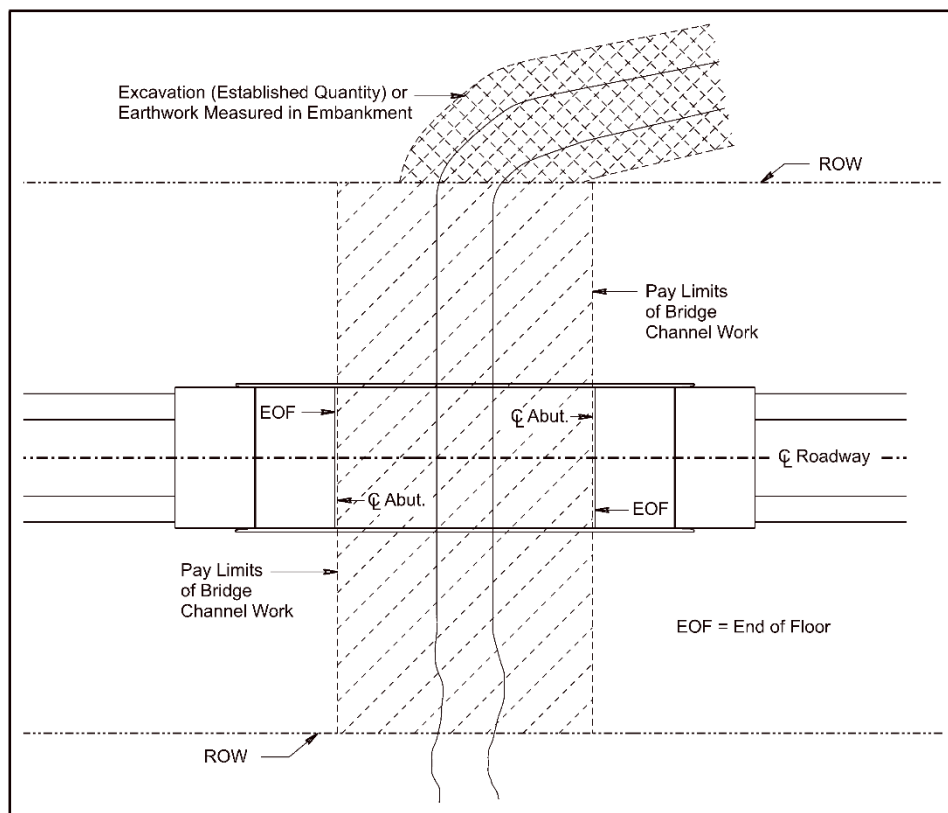
"I have determined that the channel change from Station 252 +/- 50 Rt. to Station 253 +/- Rt. does not require a grade control structure."

A copy of this transmittal shall be kept in the project file.

Deeds for land acquired for channel changes shall be written specifying the reason for the acquisition to forestall selling this land in the future. It is the responsibility of the roadway designer to inform **ROW Design** when, and what, land is being acquired for channel changes.

**5.B.6.a Bridge Channel Work**

The pay limits provided for channel work as a **Bridge Division (Bridge)** pay item will be from ROW to ROW (or as specified on the Bridge Data Sheet) and from centerline of abutment to centerline of abutment, (See EXHIBIT 13.3). Payment for channel work (and riprap) beyond the Bridge Plan quantity limits may be paid for as either Excavation (Established Quantity) or Earthwork Measured in Embankment. Excavation (Established Quantity) will be provided if the greatest earthwork net volume is excavation while Earthwork Measured in Embankment will be used if the greatest net volume is in fill. The roadway designer will coordinate with the **Bridge Designer** to decide how the work will be shown in the plans and how the limits of payment will apply.



**Exhibit 13.3 Pay Limits for Bridge Channel Work**

**5.B.7 Floodplains**

The **Federal Emergency Management Agency (FEMA)** administers the National Flood Insurance Program (NFIP). **FEMA** has established regulations for the modification of floodways and floodplains.

There can be no surcharge or increase of the 100-year flood profile resulting from highway construction in floodway (See the Drainage Design and Erosion Control Manual, (Ref. 13.6), Chapter One: Drainage, Section 5.C). If an area is mapped **FEMA** zone A or a flood fringe area on a Flood Insurance Rate Map (FIRM) and there is a local (**Town, City or County**) designated regulating authority, **NDOT** must obtain a Floodplain/Floodway permit if construction activities



occur in the mapped area. Flood Insurance Rate Maps may be found at (<https://msc.fema.gov/portal/home>). To apply for the permit a “No-Rise” certificate is required along with the application. For bridge construction activities in the mapped area, **Bridge** provides a “No-Rise” certificate and a Bridge Data Sheet. For roadway construction activities in the mapped area, **Roadway** provides a “No-Rise” certificate and a memo explaining the construction activities. Refer to Ref. 13.8 through 13.12 for further guidance. For additional information, see Chapter Seventeen: Resurfacing, Restoration and Rehabilitation (3R) Projects, Section 17.D, of this manual.

The designer will also add the appropriate floodplain wording to the PIH Report if/as required (See Appendix L “PIH Report & PQS Memo Floodplain Wording”, of this manual).

### 5.B.8 Water Quality

**NDOT** must comply with federal regulations related to water quality including the Clean Water Act (Ref. 13.5) and the Safe Drinking Water Act (Ref. 13.13), (<https://www.epa.gov/sdwa>). A Water Quality Certificate must be obtained from the **NDEQ**.

**PDD** will also research impacts of the project on any areas designed as principal or sole-source aquifers under Section 1424(e) of the Land Water Conservation Fund Act, (Ref. 13.4). If a rest area with a point source discharge is proposed as part of the project, **PDD** will also obtain a Section 402 permit (Procedures for Coordinating Highway Encroachments on Floodplains with Federal Emergency Management Agency, Ref. 13.8), (<https://www.fhwa.dot.gov/engineering/hydraulics/policymemo/0650asu3.cfm>).

**NDOT** is responsible for the quality of water exiting state right-of-way. **NDOT** is also responsible for maintaining the Stormwater Treatment Facilities (STFs) on Interstate and freeway projects (See Chapter Three: Stormwater Treatment of the *Drainage Manual*, Ref. 13.6). By statute, cities with a population over 10,000 are responsible for maintaining STFs placed on roadway projects other than Interstate and freeway. A statement highlighting this responsibility will be placed in the project agreement with the **City**.

### 5.C Air Quality

The Clean Air Act (Ref. 13.14), (<https://www.epa.gov/clean-air-act-overview>), was passed to protect and enhance the quality of the nation’s air resources. **EPA** has established air quality standards that must be followed. **Noise, Air & Hazmat** in the **Roadside Development and Compliance Unit (RDC)** of **PDD** will make all necessary air quality evaluations. Air analysis will be made for projects where the traffic exceeds 15,000 vehicles in the year of construction or 30,000 vehicles in the design year.

### 5.D Noise

Noise is defined as unwanted sound. Vehicles generate noise, and designers should work with the noise analyst to evaluate expected noise levels and measures to reduce traffic noise levels through location and design features. Sometimes embankment design and design features may serve to reduce noise levels. Criteria have been developed to analyze anticipated noise levels to determine if additional noise abatement measures should be incorporated into design. Noise sensitive areas, e.g., residences, businesses, schools, parks, etc., should be noted in the early

project stages for both developed and undeveloped lands for which development is planned, designed and programmed. The designer should work with **Noise, Air & Hazmat** if noise levels are expected to be a problem.

Noise levels should be considered during design of alignment, cross-section, earthwork balance and right-of-way. Sometimes natural barriers from the terrain may be effective noise barriers. Noise barrier structures should be located outside of the Horizontal Clear Zone if practicable. Stopping sight distance should be maintained. Some noise barrier designs incorporate concrete safety shapes. Barriers should begin or terminate at least 200 feet from the nose of gore areas. Refer to **American Association of State Highway and Transportation Officials (AASHTO) A Policy on Geometric Design of Highways and Streets** (Ref. 13.15), Chapter 4, for further information.

### **5.E Wildlife Issues**

Transportation agencies are responsible for recognizing potential conflicts between wildlife and transportation facilities and for minimizing those conflicts during all phases of roadway development. **PDD** coordinates wildlife and habitat studies and will notify **Roadway** of project-related concerns. The designer should consider the effects of roadway design on wildlife habitat and incorporate appropriate measures in project design.

Direct impacts on wildlife by roadway development stem from the disturbance of essential habitat components such as key forage areas, nesting sites, breeding grounds and essential escape cover. The Migratory Bird Act (<https://www.fws.gov/laws/lawsdigest/migtrea.html>) protects nesting bird habitat. Tree removal cannot be done during primary nesting season, (from April 1 through July 15), without a survey to check for nesting activity. If the tree removal activity will disrupt nesting, a permit must be obtained. The contractor shall be responsible for the nesting survey and for obtaining the permit. Wildlife also may be disturbed by interruptions of migration paths and highway mortality. The placement of fencing should take into consideration any restrictions it will have on animal movement. Any use of or modification to water bodies that may impact wildlife will also be included in any environmental documentation, (See Section 4.A of this chapter).

**PDD** provides early project coordination with the **Nebraska Game and Parks Commission** to identify endangered and/or threatened species concerns for use in design, copies of the determination will be provided to the designer. An endangered species is defined as any species that is in danger of extinction throughout all or a significant portion of its range. A threatened species is any species that is likely to become an endangered species within the foreseeable future throughout all or a significant portion of its range. If endangered or threatened species are concerns on a project, **EPU** will work with the designer to avoid or minimize impacts. If, at a public meeting/hearing or during other design activities, concerns are raised regarding the presence of endangered species, contact **EPU**.

**AASHTO's A Design Guide for Wildlife Protection and Conservation for Transportation Facilities** (Ref. 13.16) provides additional information, terms and concerns of the biological community.

## 5.F Social, Economic, and Environmental Impacts

As part of the social, economic and environmental review (SEE) for Class I and Class III projects (See Section 4 of this chapter) the following social impacts are considered:

1. Changes in community or neighborhood identity, such as splitting neighborhoods, isolating ethnic groups, separating residents from community facilities such as police and fire protection, school districts, churches, businesses, etc.
2. Travel patterns, accessibility, transit captives such as elderly, handicapped, non-drivers, pedestrian, bicyclists, etc.
3. Relocation impacts (See Chapter Twelve: Cost Estimating & Funding, Section 7.B.4, of this manual).
4. Impacts on the handicapped and minorities.
5. Economic impacts both for the region as well as adjacent highway-related and other businesses, etc.

Executive Order 12898 (2/11/94) (<https://www.epa.gov/laws-regulations/summary-executive-order-12898-federal-actions-address-environmental-justice>) covers Federal Actions to Address Environmental Justice in Minority Populations and Low Income Populations. **FHWA** has developed policies and procedures to use in complying with this Executive Order. Any project with Federal funding will require **NDOT**, through the NEPA process, to identify and address disproportionately high and adverse effects on minority and low-income populations. In design, avoidance, minimization, and/or mitigation must be considered for disproportionately high and adverse effects. Public involvement opportunities must be provided to the affected populations for proper alternative consideration. **PDD** will notify **Roadway** when Environmental Justice issues must be addressed.

## 5.G Archeological and Historical Features

Section 106 of the National Historic Preservation Act of 1966 (Ref. 13.17), (<https://www.achp.gov/digital-library-section-106-landing/national-historic-preservation-act>), requires an investigation be made for possible impacts of transportation projects on historic or archeological resources. A determination is necessary if any historic or archeological resources that are on or may be eligible to be on the National Register of Historic Places will be adversely impacted.

**NDOT** works with the **State Historic Preservation Officer** to evaluate sites to determine if they should be preserved or if they may be researched only, without the need for preservation. Historic sites may be bridges, buildings, neighborhoods, farmsteads, sites where significant events occurred, etc. If historic sites are present, the designer should coordinate with the **EDU Supervisor**.

## 5.H Hazardous Materials

### 5.H.1 Materials Prohibited or Restricted as Fill Materials

The **Corps of Engineers** has issued generic prohibitions of use of certain materials as fill in waters of the **United States** as defined by the Clean Water Act (33 U.S.C. 1344) (Ref. 13.5). The following materials are prohibited or restricted as fill materials in waters of the United States within the regulatory boundaries of the **Omaha District of the Corps of Engineers**:

1. Vehicle bodies, farm machinery and metal junk including appliances, containers and barrels (including plastic barrels).
2. The use of small aggregate, in the form of streambed material, for bank stabilization and erosion control below the ordinary high water mark of a waterbody or wetland when the material to be discharged is removed from a stream or river for such purpose. Small aggregate, from any source, placed below the ordinary high water mark of a waterbody or wetland when the proposed project will be unstable and subject to frequent failure.
3. The use of old or used asphalt as a fill material and the use of asphalt in general for bank stabilization or erosion control.
4. The use of organic debris (properly anchored trees and treetops are excluded).
5. Biodegradable building materials including wood debris, sheetrock, roofing materials, and chemically treated materials subject to leaching when placed in an aquatic environment. The use of clean brick and broken concrete will continue to be allowed on a case-by-case basis. Broken concrete should be free of exposed rebar and old asphalt.
6. Tires shall be prohibited unless placed in the form of a mat or other design and anchored to preclude entering the waterway.

**PDD RDC** will obtain proper authorization from the **Corps of Engineers** for any discharge of dredged or fill material into a water of the **United States**.

### 5.H.2 Guidelines for Handling Petroleum Tanks/Leaks on Construction Projects

The Resource Conservation and Recovery Act (RCRA) (Ref. 13.18), (<https://www.epa.gov/laws-regulations/summary-resource-conservation-and-recovery-act>), and the Comprehensive Environmental Response, Compensation and Liability Act (CERCLA) (Ref. 13.19), (<https://www.epa.gov/laws-regulations/summary-comprehensive-environmental-response-compensation-and-liability-act>), regulate hazardous waste sites. The locations of permitted and non-regulated hazardous waste sites should be identified.

On federal-aid highway projects, **FHWA** expects early investigation of all potential hazardous waste/petroleum sites to preclude costly delays. An initial site assessment should be done, as early as possible in the project development stages, to identify any known or potential waste site within the project limits.

For projects where no significant excavation is involved and a paper review of the tank sites reveals no problems, **NDOT** will not perform on-site drilling and testing. For projects with major excavation in the vicinity of fuel tanks, site drilling and testing may be required with the results incorporated into the EIS, (See Section 4.A.1 of this chapter).

During the on-site engineering review of projects, the locations of active and inactive fuel stations should be noted. Any stations converted to other uses should be flagged for follow-up. Once preliminary design is begun and the design is roughed out, the designer can request that the **Location Studies Unit** of **PDD** make a paper review of any fuel tank locations. The following activities will be included in the paper review:

1. Plans will be checked to see that the tank fill pipes/gas pumps are shown. A fill pipe is usually but not always directly over the tank. Vent pipes are almost always remotely located.
2. Cross-sections will be checked for cuts and fills, presence of storm sewer pipe, longitudinal or cross pipes. Even if the old grade line is matched, excavation may be needed for pavement widening, storm sewer pipes, or modern ditch sections.
3. The amount of right-of-way and its impact on existing tanks will be reviewed.
4. The **Fire Marshall's Office** will be contacted to find out tank registrations, approximate ages and sizes, when the sites were last inspected, and the results of any precision (tightness) testing.
5. The **NDEQ** will be contacted for sites on the active spill/leak list.
6. Local governments and longtime residents may be contacted for history.
7. The CERCLA map will also be checked.

Upon completion of this review, the **Location Studies Unit** of **PDD** will write a memo to **Roadway** (and **FHWA**, as appropriate, for the EIS) summarizing their findings.

In some cases, contaminated soil is not anticipated. In other cases, where questions remain, on-site drilling and testing may be needed. In those cases, the **Location Studies Unit** of **PDD** will request that **M&R** arrange testing. **M&R** will send a report to **PDD** which is then forwarded to **Roadway** and, if necessary, to **FHWA**.

### 5.H.3 Guidelines for Handling Contaminated Soils on Highway Right-of-Way

Sometimes unanticipated contaminated soils are encountered during construction activities. **NDEQ** has issued guidelines for handling petroleum-contaminated soils from an excavation or construction activity (e.g., during a trenching operation). The soils may be temporarily removed within the area of contamination and subsequently re-deposited back into the excavation and contaminated area under the following conditions:

1. The placement of underground equipment, such as a storm sewer line, cannot be allowed to act as a conduit for further migration of the contamination.
2. Impervious geological features, such as clay silt, cannot be punctured so as to open a path for contamination to migrate into an aquifer.
3. Cross-contamination of stacked fill material that expands the area of contamination cannot be allowed, i.e., the soil should not be stirred.
4. Migration of contamination from storm runoff due to the stockpiling of consolidated excavated soil cannot be allowed. The material shall be re-deposited at the end of the day or be covered with plastic cover until it is re-deposited.
5. Inversion of the layers of contamination in the replaced soil is not allowed. The contaminated soil needs to be placed back in the trench at the same layer from which it came.

These **NDEQ** guidelines do not apply to mass grading operations (e.g., cut and fill) in which contaminated soils are encountered. If contaminated soils are found during a mass grading operation, these soils need to be kept separate from the "clean" soils as recommended by **NDEQ**. Special handling will be needed.

## 6. LIAISON WITH OTHER AGENCIES AND ORGANIZATIONS

### 6.A Agreements

Intergovernmental agreements outlining the scope and participation of all parties will be executed for projects involving other units of government. The **Agreements & Consultants Services Section (Agreements)** in **PDD** prepares all agreements, except relinquishment agreements. Prior to the public hearing, covenant relinquishment agreements are prepared by **M&R**. Final relinquishment agreements are prepared prior to plans submittal to the **Plans, Specifications and Estimates Section (PS&E)**. **Design** may provide input for exhibits and/or displays which may be needed for the agreements. For additional information, see Chapter Seventeen: Resurfacing, Restoration and Rehabilitation (3R) Projects, Section 10.E, of this manual.

### 6.B Federal Agencies

Ordinarily, **FHWA** is the lead federal agency for **NDOT** contact. However, **NDOT** may also work with the **U.S. EPA, Corps of Engineers, U.S. Fish and Wildlife Service, National Park Service, FEMA, U.S. Forest Service, Bureau of Land Management, Bureau of Indian Affairs, the Architectural and Transportation Barriers Compliance Board (Access Board)** and other federal agencies. **PDD** serves as liaison with these agencies.

### 6.C Other State Agencies

**NDOT** works with many state agencies including the **Nebraska State Historical Society**, the **Natural Resource Commission**, the **Game and Parks Commission**, etc. In addition, **NDEQ** issues water quality certification, the **Advisory Council on Historic Preservation** works with **NDOT** on historic site issues, and the **Paleontological and Archaeological Highway Salvage Program** addresses archeological issues.

### 6.D Local and Regional Agencies

**PDD** coordinates with **Metropolitan Planning Organizations (MPOs)** in metropolitan areas, and the **Local Assistance Division** coordinates with city and county governments, natural resource districts, et. al.

### 6.E Public Participation and Input

Federal Policy requires public involvement in the development of transportation plans. The public participates in the planning process through the **State Highway Commission**, the **Board of Public Roads Classifications and Standards** and through other committees, meetings and hearings. In addition, information about transportation plans, projects and programs is disseminated through the public media and through mailings to interested organizations and individuals such as the **Nebraska Highway Coalition**, the **American Automobile Association**, the **Nebraska Motor Carriers Association**, etc.

Types of public meetings that are held by the **Roadway** include public information meetings, city officials meetings, pre-hearings, location public hearings, and design public hearings.

Communication between **NDOT** and the public is an important ongoing activity coordinated by the **Public Involvement Specialist** in the **Communications and Public Policy Division (Communications)**. Depending upon the nature of the project, several types of contact may be made during the course of a project.

The **Public Involvement Specialist** publishes notices of opportunity for hearings in general circulation newspapers in project areas to provide general information about the proposed projects to the general public and also to provide them the opportunity to submit a written request to **NDOT** to hold a public hearing. If no requests are submitted, **NDOT** may notify **FHWA** that no requests were received and that hearing requirements were thus satisfied.

## 6.F Consultants

Consultants are hired to assist **NDOT** on various projects. **Agreements** provides liaison with consultants, including:

- Participating in the selection of and negotiation with consultants.
- Maintaining certification records of consultants.
- Reviewing consultant billings.

Engineers who work in the **Consultant Design Units** in **Roadway** will be responsible for day to day business contacts with consultants including transmittal of data, progress inspections and meetings as set out in the scope of work. This does not include authorization to change the scope of work for the project, to exceed the agreed upon project cost or to extend the completion date. These authorizations come from the **Agreements Engineer**. If a change in scope of work is necessary, it should be discussed with the **Agreements Engineer** and that office will prepare a supplemental agreement for the additional cost. If a time extension is necessary, the **Agreements Engineer** will ask the consultant to provide a written extension request and will discuss this with the appropriate **Division** for approval of the time extension.

The **Agreements Engineer** should be informed of design public hearings so he/she can be prepared to have the consultant ready to go on Roadway Design Details. The **Agreements Engineer** will set up the scope of work and be in charge of the negotiations. Following a design public hearing, the negotiations will be completed so the consultant will be ready for Roadway Design Details as soon as approval is received from the **State Highway Commission** and **Governor**.

## 7. REFERENCES

- 13.1 National Environmental Policy Act of 1969: 42 U.S.C. 4321-4347, 23 CFR 771 Environmental Impact and Related Procedures, 40 CFR 1500-1508 Council on Environmental Quality Regulations. (<https://ceq.doe.gov/>)
- 13.2 Nebraska Department of Transportation, Design Process Outline, Current Edition. (<https://dot.nebraska.gov/business-center/design-consultant/>)
- 13.3 Section 4(f), U.S. Department of Transportation Act of 1966. (<https://www.environment.fhwa.dot.gov/legislation/section4f.aspx>)
- 13.4 Section 6(f), Land Water Conservation Fund Act. ([https://www.environment.fhwa.dot.gov/env\\_topics/4f\\_tutorial/related.aspx](https://www.environment.fhwa.dot.gov/env_topics/4f_tutorial/related.aspx))
- 13.5 Clean Water Act of 1977, 33 U.S.C. 1251 et seq. (<https://www.epa.gov/cwa-404/overview-clean-water-act-section-404>)
- 13.6 Nebraska Department of Transportation, Drainage Design and Erosion Control Manual, Current Edition. (<https://dot.nebraska.gov/business-center/design-consultant/rd-manuals/>)
- 13.7 Section 10, Rivers and Harbors Act of 1899, 33 U.S.C. 403, as amended and supplemented, 33 CFR 114-115. (<https://www.epa.gov/cwa-404/section-10-rivers-and-harbors-appropriation-act-1899>)
- 13.8 U.S. Department of Transportation, Federal Highway Administration, "Procedures for Coordinating Highway Encroachments on Floodplains with Federal Emergency Management Agency." (<https://www.fhwa.dot.gov/engineering/hydraulics/policymemo/0650asu3.cfm>)
- 13.9 "The Floodway: A Guide for Community Permit Officials," Federal Emergency Management Agency.
- 13.10 Executive Order No. 11988: Floodplain Management (as amended by Executive Order 12148). (<https://www.epa.gov/cwa-404/floodplain-management-executive-order-11988>)
- 13.11 Executive Order No. 11990: Federal Wetlands. (<https://www.epa.gov/cwa-404/protection-wetlands-executive-order-11990>)
- 13.12 U.S. Department of Transportation, Federal Highway Administration, "Location and Hydraulic Design of Encroachments on Flood Plains, Federal Aid Policy Guide, Volume 6, Chapter 7, Section 3, Subsection 2. (<https://www.gpo.gov/fdsys/pkg/CFR-2011-title23-vol1/pdf/CFR-2011-title23-vol1-part650-subpartA.pdf>)
- 13.13 Safe Drinking Water Act: 42 U.S.C. 300f, 300h and 300j-6, 23 CFR 650, Subpart E. (<https://www.epa.gov/sdwa>)



- 13.14 The Clean Air Act: 23 U.S.C. 109(1) as amended, 42 U.S.C. 7401-7428. (<https://www.epa.gov/clean-air-act-overview>)
- 13.15 American Association of State Highway and Transportation Officials, A Policy on the Geometric Design of Highways and Streets, Washington, DC., 2011.
- 13.16 American Association of State Highway and Transportation Officials, A Design Guide for Wildlife Protection and Conservation for Transportation Facilities, 1976, Washington, DC.
- 13.17 Section 106, National Historic Preservation Act as amended: 16 U.S.C. 470f. (<https://www.achp.gov/digital-library-section-106-landing/national-historic-preservation-act>)
- 13.18 Resource Conservation and Recovery Act of 1976 (RCRA) as amended: 42 U.S.C. 6901, 40 CFR 260-271. (<https://www.epa.gov/laws-regulations/summary-resource-conservation-and-recovery-act>)
- 13.19 Comprehensive Environmental Response, Compensation and Liability Act of 1980 (CERCLA), as amended: 42 U.S.C. 9601-9657 (<https://www.epa.gov/laws-regulations/summary-comprehensive-environmental-response-compensation-and-liability-act>)



Chapter Fourteen presents guidance for the design of New and Reconstructed projects; design guidance for 3R projects is provided in Chapter Seventeen.

# Chapter Fourteen

## Traffic

### 1. TRAFFIC ENGINEERING STUDIES

The **Traffic Engineering Division (Traffic Engineering)** is responsible for conducting a variety of studies, which are summarized in the following sections. The roadway designer is responsible for requesting information from **Traffic Engineering**.

#### 1.A Capacity Analysis

The principal objective of capacity analysis is to estimate the amount of traffic that can be accommodated by a given set of geometric features and to provide metrics for comparison of alternatives while maintaining a desired level of service. For example, this information can be used to determine whether improvements are needed or not. If so, the information can be further utilized to evaluate alternative geometric configurations. The roadway designer should confirm with **Traffic Engineering** that the design typical section and alignment contained in the Planning Document provides the intended capacity and level of service for the project (See Chapter Four: Intersections, Driveways and Channelization, Section 1.C.1, of this manual).

#### 1.B Safety Analysis

A safety analysis uses factors such as crash history, traffic volume data, and roadway configuration to predict the future performance of the roadway in terms of crash frequency and severity. A safety analysis may be used to determine the extent of project improvements, which may include:

- Roadway geometry
- Intersection improvements
- Shoulder width
- Rumble strips/stripes
- Superelevation rates
- Roadside improvements
- Roadside barrier installation/retention
- Speed limits
- Auxiliary lanes

A safety analysis may be used in evaluating the expected average crash frequency under both existing and proposed conditions. This evaluation may be assessed with other considerations such as, but not limited to, capacity, right-of-way costs, and environmental impacts, aiding the roadway designer in focusing project resources in areas which are in the greatest need of improvement thereby maximizing the efficient expenditure of **Nebraska Department of Transportation (NDOT)**, federal, and local funding.

### 1.C Volume Studies

Traffic volume studies are conducted to determine the levels of traffic along highways or at intersections during specified time periods (e.g. annual average daily traffic (ADT), peak hour traffic). Traffic study results are used to recommend the appropriate design standard and for planning, capacity analysis, accident rate analysis, and for other studies as needed.

### 1.D At-Grade vs. Interchange Recommendations

**Traffic Engineering** assists in the development of recommended interchange types and designs to be considered where two or more roadways intersect (at-grade intersection, interchange, roundabout, or other alternatives). For additional information see Chapter Four: Intersections, Driveways and Channelization, Section 1 and Chapter Five: Interstates, Grade Separations, and Interchanges of this manual.

### 1.E Weaving Section Analysis

**Traffic Engineering** analyzes weaving sections where traffic entering and exiting a roadway facility will cross paths. The length and number of lanes necessary in a weaving section are determined using capacity analysis techniques.

### 1.F Lane Configuration

Auxiliary lanes may be provided for left turns, right turns, or free flow right turns as recommended by **Traffic Engineering**. The length of the turn lane is typically determined by a combination of storage length and deceleration/taper requirements. Storage needs are often developed through a capacity analysis while deceleration/taper is typically obtained from design guidance documents. Turn lane length should be verified with **Traffic Engineering** (See Chapter Four: Intersections, Driveways and Channelization, Section 1.D, of this manual).

### 1.G Traffic Control Studies

Traffic control determination is the responsibility of **Traffic Engineering**. Recommendations for traffic control devices at intersections are made with regard to the type of traffic control necessary (none, yield sign, stop sign, or traffic signal) (See the Manual on Uniform Traffic Control Devices for Streets and Highways (MUTCD), Ref. 14.1, and the State of Nebraska, Supplement to the Manual on Uniform Traffic Control Devices, Ref. 14.2, <https://dot.nebraska.gov/business-center/contractor/mutcd/>). If traffic signalization is recommended, **Traffic Engineering** will develop the traffic signal design. For additional information see Section 4 of this chapter and Chapter Four: Intersections, Driveways and Channelization, Section 1.E.

## 1.H Pedestrian Crossings

Pedestrian crossings are used to facilitate the movement of the walking public, people in wheelchairs, and/or bicyclists across highways, railroad tracks, and rivers or streams. Warrant analysis for mid-block pedestrian crossings are the responsibility of **Traffic Engineering**. The roadway designer will coordinate the design of the pedestrian crossing with the design of the highway, sidewalk/bikeway/shared-use path, railroad crossing, or bridge. For additional information, see Section 4.A of this chapter, Chapter Four: Intersections, Driveways and Channelization, Section 1.C.10, and Chapter Sixteen: Pedestrian and Bicycle Facilities, Section 7.

## 2. ROADWAY SIGNS

Roadway signs are used to regulate traffic operations by advising/informing motorists of roadway rules, hazards, or function. These signs are provided to promote efficient vehicle operation on highways. Signing should be considered as an integral part of design and should be designed concurrently with the geometry of the roadway. The roadway designer will send notification that the preliminary roadway design is available to **Traffic Engineering** at "Roadway Design", Activity 5300, Clarity Task Code 5350 (See the Design Process Outline (DPO), Ref. 14.3) (<https://dot.nebraska.gov/business-center/design-consultant/>).

Supports for highway signs are considered as obstacles to motorists. The supports should be located outside of the Horizontal Clear Zone; they should be crashworthy or shielded if they are inside the Horizontal Clear Zone (See Chapter Six: The Typical Roadway Cross-Section, Section 9.A, of this manual).

**Traffic Engineering** determines the need for overhead signs. Although the roadway designer does not design the signs, the roadway designer will confirm that overhead signs are included in the cost estimate for the project and will verify that the locations of overhead signs meet horizontal and vertical clearances as defined in the Nebraska Minimum Design Standards (MDS), Ref. 14.4 (<https://dot.nebraska.gov/media/1z1n5kmb/nac-428-rules-regs-nbcs.pdf>) and in Chapter Three: Roadway Alignment, Section 3.D.

### 3. MARKINGS

Markings are an integral part of roadway design and should be designed concurrently with the geometry of the roadway. There are three general classifications of markings: pavement markings, object markers, and delineators.

Pavement markings are line markings such as center lines, edge lines, lane lines, parking lines, cross walk lines, and other symbols and legends. The roadway designer will consider the location of pavement markings when creating pavement jointing diagrams for Portland Cement Concrete pavement (See Chapter Eight: Surfacing, Section 2.A.2.a, of this manual); the joints should be in the same location where the markings will be to provide positive guidance to the driver when the markings may be difficult to see. The roadway designer will submit a preliminary jointing diagram to **Traffic Engineering** for review as soon as the alignment and roadway geometry are designed during "Roadway Design Details", Activity 5500, Clarity Task Code 5508 (See the *DPO*, Ref. 14.3).

Object markers warn of physical obstructions within or adjacent to the roadway that pose an obstacle to motorists such as piers, bridge abutments, flumes, and culvert headwalls. Object markers may warn of roadside conditions, such as abrupt changes in alignment or the end of a roadway.

Delineators are retroreflective devices mounted at the side of the roadway. They are used to guide traffic, especially at night. The units are installed at specified heights and spacing to delineate changes in the roadway. The roadway designer is responsible for determining the locations, spacing, and quantity of the delineators for a project and should refer to the Standard/Special Plans Book (*Standard Plans*) (Ref. 14.5) (<https://dot.nebraska.gov/business-center/design-consultant/stand-spec-manual/>) for guidance. The roadway designer should discuss the lateral offset distance of the delineators with **District** on the plan-in-hand; the offset determines the length of the delineator post which impacts the item cost.

#### 4. TRAFFIC SIGNALS

Traffic signals are used to direct conflicting movements of vehicles and/or pedestrians by assigning the right-of-way to various movements at different times. The design of traffic signals and signal timing is the responsibility of **Traffic Engineering** and should be coordinated with the design of the intersection geometry. **Traffic Engineering** may recommend the installation of conduits and loops for future work. Refer to Chapter Four: Intersections, Driveways and Channelization, Section 1.E.2, for additional information concerning the coordination of signal design with intersection design.

##### 4.A Pedestrian Signals

Warrant analysis for pedestrian crossing signals, as outlined in the *MUTCD* (Ref. 14.1), is the responsibility of **Traffic Engineering**. For further information, see Section 1.H of this chapter.

Accessible pedestrian signals are devices that provide non-visual guidance for those with visual disabilities. They are not routinely installed on signal projects, but can be installed upon request and the completion of an engineering study determining their need. The engineering study generally includes a discussion of need and locations with the requesting party. If pedestrian signals are installed on a project, the roadway designer should account for any project impacts such as the need for additional right-of-way for signal poles and pavement sawing, removal and replacement for the installation of detection conduits.

## 5. INTELLIGENT TRANSPORTATION SYSTEM

An Intelligent Transportation System (ITS) uses technology (e.g. traffic sensors, traffic cameras, computers, modern communications) to collect and analyze transportation data such as traffic flow, traffic speed, crashes, and other information. This information is sent to a control center where traffic control and enhancement strategies (such as anti-icing systems, signal timing or alternate routes) may be developed using real-time data. The strategy may then be transmitted to the driving public through such methods as message boards, radio announcements, GPS systems, self-driving cars, and other communication methods. The effective use of ITS may enhance the transportation system in many ways including reduced congestion, improved traffic flow, reduced crash potential, drivers alerted to adverse road conditions, improved efficiency of public transportation, a reduction in fuel usage and a reduction in air pollution. An efficient transportation system may also negate or delay the need for the expensive construction of additional traffic lanes.

In accordance with 23 CFR 940.11, "Project Implementation", (<https://www.fhwa.dot.gov/legsregs/directives/fapq/cfr0940.htm>) (Ref. 14.6), all ITS projects funded with highway trust funds shall be based on an engineering systems analysis. This analysis should be on a scale commensurate with the project scope.

When a project impacts existing ITS elements (e.g. cutting the power, moving the device, damaging the system), the roadway designer will coordinate with the **Roadway Design ITS/Lighting Unit** to verify that the project includes sufficient plans, provisions, and right-of-way to place the elements back to working order. This may include in-pavement systems into new pavement construction and/or sawing pavement for a retro-fit of the system. New ITS deployments are the responsibility of the **ITS/Lighting Unit**. For any additional information, contact the **ITS/Lighting Unit**.



## 6. WORK ZONE TRAFFIC CONTROL

**Traffic Engineering** is responsible for developing a traffic control plan (TCP) consisting of warning signs, markings, channelization devices, or other methods. The roadway designer will address construction-sequencing issues and coordinate the development of the traffic control plan with **Traffic Engineering** as early as possible in the design process.

When preparing roadway and construction phasing plans, the roadway designer should consider:

- The use of a detour versus construction under traffic
- The delay cost of a detour
- The capacity of a detour or temporary road to handle the expected traffic around or through the construction zone
- If the detour/temporary roadway geometry will meet or exceed minimum guidelines
- Roadside safety and clear zone requirements
- The constructability of the phasing
- The economic costs to users and adjacent property owners and businesses
- Community and social impacts, local festivals
- The maintenance of access to adjacent property owners

### 6.A Construction Under Traffic

The majority of projects will be built under traffic, when practicable. It may be necessary to encroach upon travel lanes, shift lanes, or even close lanes during construction. The frequency and length of time that traffic must be routed through the construction zone should be kept to a minimum and adequate warning will be provided to motorists.

The roadway designer should consider construction sequencing and the maintenance of traffic during construction throughout the entire design process. The following items should be considered and provided for in the design of a project that is to be built under traffic:

- Provide a minimum width of four feet for worker protection (two feet for barrier width and a two-foot clear space behind the barrier). Consult with **Traffic Engineering** regarding the barrier layout.
- Taper lengths for lateral lane transitions and lane drops should meet or exceed the minimums set by the *MUTCD* (Ref. 14.1).
- Day and night sight distances should meet or exceed the minimums presented in the **American Association of State Highway and Transportation Officials (AASHTO) A Policy on Geometric Design of Highways and Streets (Green Book)** (Ref. 14.7), Chapter 3, Section 3.2, "Sight Distance".

Often road improvements such as milling, armor coat, asphalt surfacing, and shoulder work will require the closing or partial closing of travel lanes on highways during construction. On highways of four lanes or more this may simply involve reducing the number of lanes in each direction so construction work can be completed or in the closing of two of the directional lanes (e.g. the eastbound lanes), shifting the traffic to the other lanes in an opposing traffic configuration by the construction of crossovers (See Section 6.A.1 of this chapter). On two-lane highways this may involve such methods as closing one lane and using a flagger to direct traffic through the

construction, the use of stop signs, yield signs, temporary signals, or other methods as the situation allows. **Traffic Engineering** will recommend the type of traffic control that is suitable. On roadways with high traffic volumes, it may be practicable to schedule construction at night, closing the roadway and detouring traffic to another route. The roadway designer will coordinate with the **Construction Division** and with **Traffic Engineering** regarding the construction schedule (day or night) and the number of lanes that will be open to traffic.

#### **6.A.1 Crossovers**

Crossovers are used on multi-lane divided highways to temporarily route traffic across the median to the opposite lanes so that construction can progress on the vacated side. Additional earthwork needed to construct the crossovers will be included in the earthwork quantities (See Chapter Seven: Earthwork, Section 2, of this manual). Single lane crossovers should be designed with 16 foot lane widths. The crossover pavement quantities will be included in the cost estimate and paid for separately (See Chapter Twelve: Cost Estimating & Funding, EXHIBITS 12.8 & 12.9, of this manual).

For information regarding left-in-place median crossovers, see Chapter Five: Interstates, Grade Separations, and Interchanges, Section 1.H.4, of this manual.

#### **6.A.2 Temporary Surfacing**

Additional temporary surfacing may be needed during different phases of construction for lane or shoulder widening, property entrances, etc. These surfacing quantities will be included in the cost estimate and paid for separately (See Chapter Twelve: Cost Estimating & Funding of this manual).

On New or Reconstructed projects with major grading involving disrupted accesses, the roadway designer should discuss the use of gravel, crushed rock, or millings with **District** on the plan-in-hand field inspection. These materials may be used to provide temporary access to adjacent properties during construction (See Chapter Twelve: Cost Estimating & Funding, EXHIBITS 12.5, 12.8 & 12.9, of this manual).

## 6.B Temporary Roads

In certain situations (e.g. the construction of culverts), it may be more practicable to construct a short route around the work zone than to build the project under traffic or to utilize a detour (See [EXHIBIT 14.1](#)). The following considerations apply in the design of a temporary road:

**Right-of-Way** - Right-of-way should be adequate to construct the temporary road or an easement will be acquired.

**Design Vehicle** – The temporary road should be designed using the same design vehicle as the project (See Chapter Four: [Intersections, Driveways and Channelization](#), Section 1.C.5, of this manual).

**Design Speed** – As a rule-of-thumb, the design speed for the temporary road should be 10 mph less than the existing posted speed.

**Sight Distance** – Stopping sight distance and intersection sight distance will be based on the design speed of the temporary road. The roadway designer should pay particular attention to sight distance where there is a combination of horizontal and vertical curves. For additional information see the *Green Book* (Ref. 14.7), Chapter 3, Section 3.2, “Sight Distance, and Chapter 9, Section 9.5, “Intersection Sight Distance”.

**Typical Section** - Typical temporary road sections are shown in [EXHIBIT 14.2](#).

**Grades** – Grades will be designed based on the temporary road design speed, the maximum allowable grade is 10% (See Chapter Three: [Roadway Alignment](#), Section 3.A, of this manual).

**Transitions** – Traffic may be moved between the main roadway and the temporary road by the use of tapers, curves, or a combination of the two.

1. **CURVES** – Horizontal curves should be designed according to the design speed of the temporary road. High-speed temporary roads ( $V \geq 50$  mph) should be designed according to the  $e_{\max} = 6\%$  superelevation table found in Chapter Three: [Roadway Alignment](#), [EXHIBIT 3.4c](#). Low-speed temporary roads ( $V \leq 45$  mph) should be designed in accordance with **FIGURE 3-7** of the *Green Book* (Ref. 14.7), using a relative gradient of 185:1. See Chapter Three: [Roadway Alignment](#), Section 2.B, of this manual for information on the design of horizontal curvature.
2. **TAPERS** – Taper rates between 29:1 ( $2^\circ$ ) and 11:1 ( $5^\circ$ ) are allowed. A 20:1 taper rate is recommended.

**Lateral Clearance to the Work Zone (Buffer Space)** - The distance required between the centerline of a temporary road section and the project centerline will be determined on a case-by-case basis. Factors affecting the required width of this space include construction clearances, side slope geometry, and temporary drainage requirements.

When a temporary road is required adjacent to bridge construction/reconstruction, the roadway designer will coordinate with the **Bridge Division (Bridge)** regarding the lateral offset of the temporary road to the bridge (See [EXHIBIT 14.2](#)) and the required size of the drainage structure(s) needed to handle the water flow or the use of a temporary bridge structure.

**Drainage** - Existing drainage patterns will be maintained to prevent flooding of the existing roadway and surrounding properties. Drainage structures needed to construct the temporary road will be included in the cost estimate and any required connection bands will be added to the build notes and cost estimates. If temporary drainage pipe is to be retained by the **District**, they should be consulted regarding the pipe lengths and diameters that can be used when the pipe is salvaged.

The roadway designer should pay particular attention to the drainage of the temporary road surface where there is a combination of horizontal and vertical curves.

**Earthwork** - Earthwork quantities for temporary roads will be included in the project earthwork calculations. Temporary road material will be placed as embankment and removed as excavation, specified for the temporary road. Construction phasing and material location should be considered in the earthwork quantities, verify that material is available for the construction of the temporary road.

**Surfacing - District** will determine the type of surfacing for each temporary road at the plan-in-hand inspection. The following considerations should be kept in mind:

- Pavement used to construct the temporary road will be structurally adequate to handle expected traffic.
- Pavement used to construct the temporary road will be estimated for the same quantity items as for the main roadway (See Chapter Twelve: Cost Estimating & Funding, EXHIBITS 12.8 & 12.9, of this manual) and will be included in the pavement quantities.
- If gravel surfacing is used, gravel embedment is required.

The roadway designer will do the preliminary calculations. The following individuals will calculate the final quantities, depending on the type of temporary road surfacing to be used:

Temporary Road Surfacing Type	Final Quantity Calculations by:
Concrete	Roadway Designer
Asphaltic Concrete	<b>M&amp;R</b>
Gravel & Gravel for Embedment	Roadway Designer
Embedment of Gravel	<b>M&amp;R</b>
Calcium Chloride	<b>M&amp;R</b>

**Traffic Engineering** – The roadway designer will submit the temporary road design, including design speed, to **Traffic Engineering**. **Traffic Engineering** will determine the pavement markings and signals needed to construct the temporary road, which will be included in the cost estimate.

**Erosion Control** – Temporary erosion control measures will be required for temporary road construction. Temporary erosion control methods may be found in Chapter Two: Erosion and Sediment Control, Section 5, of the Drainage Design and Erosion Control Manual (Drainage Manual) (Ref. 14.8) (<https://dot.nebraska.gov/media/ajjpyh3d/e-chap-2-erosion-control.pdf>). The roadway designer will review the temporary road design with the **Roadside Development & Compliance Unit** in the **Project Development Division**.

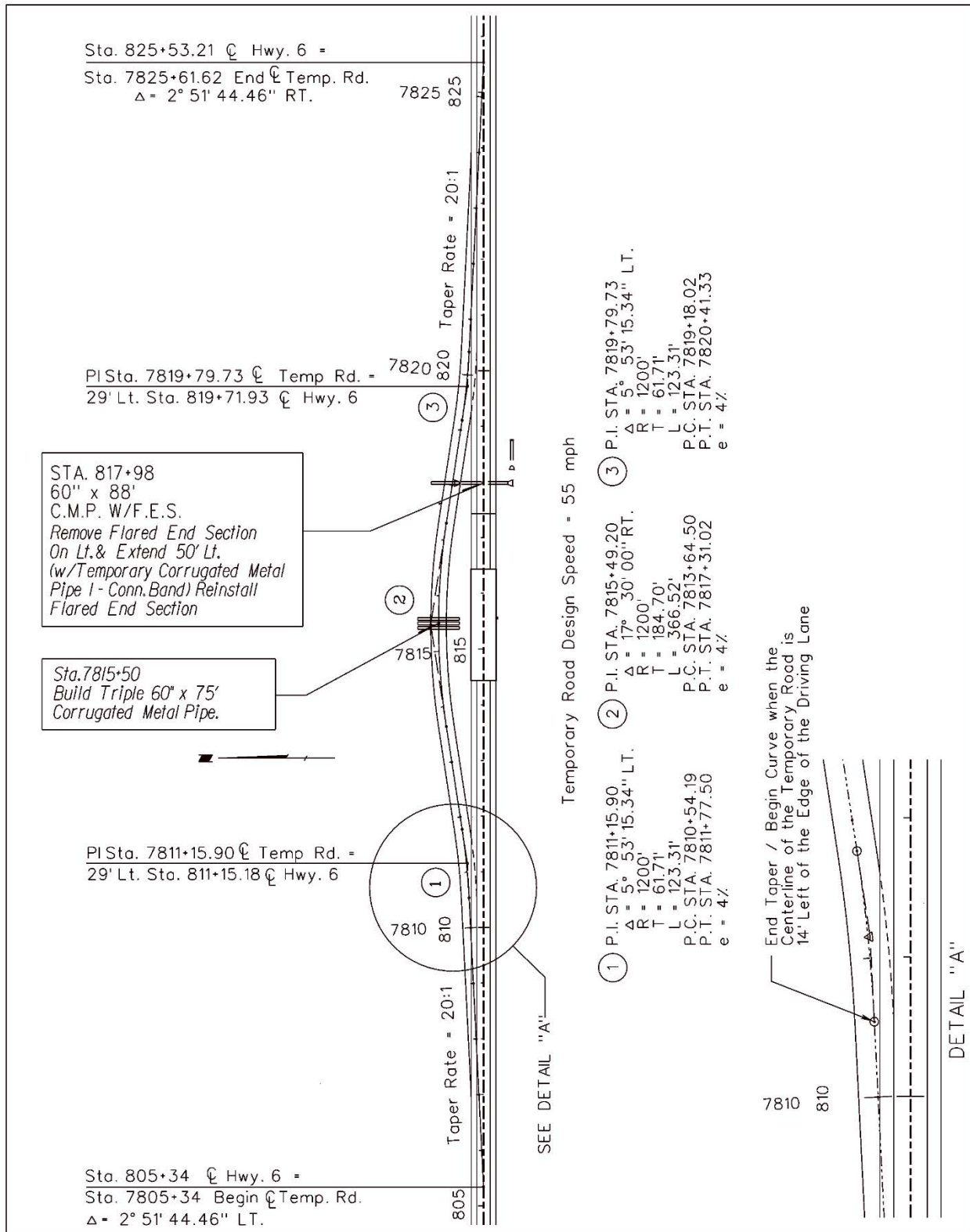
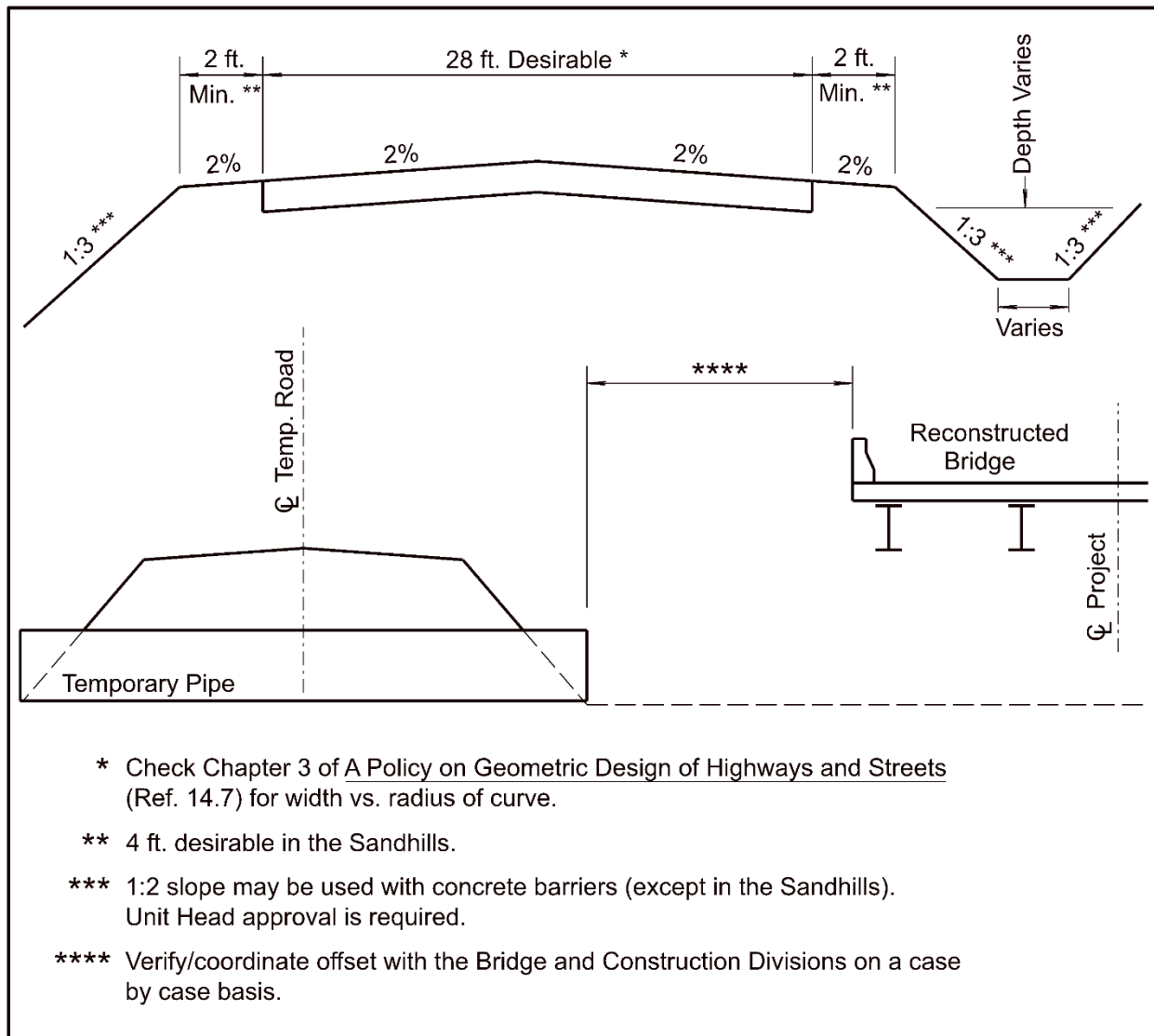


Exhibit 14.1 Example Temporary Road



**Exhibit 14.2 Typical Temporary Road Section**

### 6.C Identification of Work Zone “Significant Projects”

A projects’ effect on the flow of traffic through the work zone is critical to the success of the project in the public’s perception. Projects which have the possibility of congesting traffic beyond acceptable delays may be considered a “significant project”

A project may be labeled “significant” because it is:

Located within the boundaries of the **Transportation Management Areas (TMA)** of **Omaha** or **Lincoln** and the project is expected to occupy a location for more than three (3) days with either intermittent or continuous lane closures.

or

**Project Characteristics** - including but not be limited to project type, type of work zone (full closure, lane reductions, crossovers, night work, etc.), project schedule, area type (urban, suburban, rural).

**Travel and Traffic Characteristics** - including but not be limited to traffic volumes, seasonal and temporal variations, vehicle mix, type of travel (commuter, tourist, freight), public and private access, special events, weather impacts.

**Work Zone Characteristics** - including but not be limited to impacts on local and regional transportation networks, capacity issues, level of public interest, number of travelers impacted, expected safety impacts, expected delays, impacts on nearby commercial, public, and private facilities and properties.

or

Because the **District Engineer (DE)** so designated it.

For additional information see Appendix J, “Guidelines for Addressing Work Zone Mobility and Safety”, Section 4, of this manual.

A “Significant Project” designation requires:

- A decision at the Plan-In-Hand (PIH) & inclusion in the PIH Report.
- The **Traffic Control Engineer** will determine whether a project is “Significant” or not prior to and reconfirm after the PIH & include the decision reached in the PIH report.

Public participation **will be required** when a project is declared a “Significant Project”. (For additional information see Appendix J, “Guidelines for Addressing Work Zone Mobility and Safety”, Section 5, of this manual).

**PS&E Turn-in Sheet:** Check the box reading “Work Zone Significant Project Spec. (PS&E Plans)”. This means that the project will include a special provision that refers to a Traffic Control Plan and other items that will need to be taken care of during the project.

For additional information, see Appendix J, “Guidelines for Addressing Work Zone Mobility and Safety”, of this manual.

## 6.D Detours

Detours may guide traffic around construction zones outside of the project limits. A detour is a signed route within an existing roadway system that is appropriate for the intended traffic and the intended duration. The detour route(s) should be determined prior to the plan-in-hand for NEPA review and processing.

The following items should be considered in determining if a detour route is feasible and should be verified at the plan-in-hand:

- The delay cost of the detour; the roadway designer should coordinate with the **Highway Construction Scheduling Manager** in the **Construction Division**.
- Existing road(s) will be able to handle the expected volumes of traffic generated by the proposed detour. The roadway designer will design any required improvements to the detour roadway and/or intersection geometry.
- Bridges on the detour route shall be structurally adequate for the expected traffic composition. The roadway designer will coordinate bridge/bridge size structures on the detour route with **Bridge**.
- Existing pavement(s) shall be structurally adequate to handle the expected traffic volumes; the roadway designer will coordinate with the **Pavement Design Engineer** in the **Materials and Research Division** regarding necessary surfacing improvements.
- Environmental considerations/impacts along the detour route.
- The detour route should be a reasonable length, not requiring the motorist to travel too far from the normal route.
- The impact of the detour route on the operation of businesses, both along the project route and the detour.
- Local access will be provided to residents and businesses.
- The impact of the detour route on emergency vehicle operations.
- The impact of the detour route on school bus routes and schedules.
- Railroad crossings on the detour route; railroad crossing upgrades, crossing signals, and agreements with the railroad company will be coordinated with the **Rail Unit** in the **Local Assistance Division**.

The **District Operations & Maintenance Manager** should be consulted at the plan-in-hand about the feasibility of maintaining the detour during construction.

The roadway designer will coordinate the detour route selection and any improvements with the **District** and with all impacted **Divisions/Units** (e.g. **Bridge, Project Development, Construction**). The roadway designer will submit the proposed detour route to **Traffic Engineering** for review.

The selected route may require temporary geometric and surfacing improvements to handle the intended detour traffic. Pavement needed for detour improvements is paid for under a separate pay item group; the roadway designer will compute quantities of surfacing and other construction items required for the detour improvements (See Chapter Twelve: Cost Estimating and Funding, EXHIBITS 12.5, 12.8 & 12.9, of this manual).



If roads other than state highways are proposed for use as a detour, a signed agreement must be obtained from the appropriate governing agencies. The agreement will outline the surfacing, geometric, and other improvements to be accomplished and will depict the detour route. The **City/County** should be contacted early in the design process, informing them about the proposed detour route(s) and requesting information regarding local construction projects or special events (e.g. parades, local festivals) that will affect the choice and/or allowable time frame of a detour route. Proposed detour routes will be addressed at public meetings.

## 7. REFERENCES

- 14.1 United States Department of Transportation Federal Highway Administration, Manual on Uniform Traffic Control Devices for Streets and Highways (MUTCD), Washington, D.C., 2009. (<http://dot.nebraska.gov/business-center/contractor/mutcd/>)
- 14.2 State of Nebraska, Supplement to the Manual on Uniform Traffic Control Devices, 2011 (<https://dot.nebraska.gov/business-center/contractor/mutcd/>)
- 14.3 Nebraska Department of Transportation, Design Process Outline (DPO), Current Edition. (<https://dot.nebraska.gov/business-center/design-consultant/>)
- 14.4 Board of Public Roads Classifications and Standards, Nebraska Minimum Design Standards (MDS), Current Edition. (<https://dot.nebraska.gov/media/1z1n5kmb/nac-428-rules-regs-nbcs.pdf>)
- 14.5 Nebraska Department of Transportation, Standard/Special Plans Book (Standard Plans), Current Edition. (<https://dot.nebraska.gov/business-center/design-consultant/stand-spec-manual/>)
- 14.6 Title 23 of the “Code of Federal Regulations”, Chapter I – Subchapter K – Part 940 (23 CFR 940.11) (<https://www.fhwa.dot.gov/legsregs/directives/fapg/cfr0940.htm>)
- 14.7 American Association of State Highway and Transportation Officials, A Policy on Geometric Design of Highways and Streets (Green Book), Washington, D.C., 2018.
- 14.8 Nebraska Department of Transportation, Drainage Design and Erosion Control Manual, Current Edition (<https://dot.nebraska.gov/business-center/design-consultant/rd-manuals/>)

The information contained in Chapter Fifteen: Right-of-Way, dated May 2022, has been updated to reflect the October 2023 Errata. The errata addresses errors, changes in procedure, changes in NDOT department titles, changes in other Roadway Design Manual chapters and other reference material citations occurring since the latest publication of this chapter.

Chapter Fifteen presents guidance for the design of New, Reconstructed, and 3R projects; additional design guidance for 3R projects is provided in Chapter Seventeen.

## Chapter Fifteen Right-of-Way

This chapter provides general information regarding the design and acquisition of right-of-way. Right-of-way is land, either owned or with a right of usage (easement), utilized for transportation purposes. For additional information refer to the Right-of-Way Manual (Ref. 15.1) (<https://dot.nebraska.gov/media/0sopjmah/row-manual.pdf>).

### 1. RIGHT-OF-WAY SURVEY

A right-of-way survey will be required whenever a proposed highway improvement includes the acquisition of permanent easement rights and/or the purchase of additional land. The need for a right-of-way survey for temporary easements will be determined on a case-by-case basis. The **Right-of-Way Design Engineer** determines which projects require a right-of-way survey; information used to determine the need for a right-of-way survey includes:

- The “Highway Improvement Programming Request” (NDOT Form 73), provided by the **Program Management Division (Program Management)**
- The “Planning Document”, provided by the **Project Development Division (PDD)**
- Additional input from **Roadway Design**
- Additional input from the **District Engineer (DE)**

### 2. RIGHT-OF-WAY DESIGN PLANS

The **Right-of-Way Design Division (ROW Design)** is responsible for the coordination and preparation of the following right-of-way design plans:

#### 2.A Existing Plans

**ROW Design** maintains an archive of plans of previous projects in OnBase showing existing right-of-way, easements, and control of access. These plans may be found in “Document Types and Groups/NDOT ROW Design/NDOT ROW Archive Plans”. They may also be accessed by a custom query for “NDOT All Contract/Project Documents” and a search by Control Number. These plans may be used to determine if right-of-way will be needed on a project and in the creation of Ownership Plans (See Section 2.C of this chapter).

## 2.B Corridor Protection Plans

Highways in areas which may have residential and/or commercial development occurring prior to a planned highway improvement will be reviewed for corridor protection. Corridor protection is a procedure whereby the **Nebraska Department of Transportation (NDOT)** notifies the appropriate local government agencies and the general public of a planned transportation improvement and the intent to acquire right-of-way along a highway corridor. Corridor protection is designed to allow **NDOT** to review proposed development that may occur adjacent to the selected highway corridor, minimizing acquisition costs and reducing or eliminating development impacts to the highway project.

If corridor protection is needed, a recommendation will be made by **PDD, Roadway Design, ROW Design**, or the **District**. The **ROW Division (ROW)** has the responsibility for establishing corridor protection on state highways and notifying the public that corridor protection has been filed.

The following steps are required before initiating corridor protection on a new alignment:

- A location public hearing
- Approval of the draft NEPA document, if applicable
- A recommendation from the **Highway Commission**
- Approval from the **Governor**

The above steps are not required to initiate corridor protection on an existing alignment.

If corridor protection is needed and a relinquishment is involved, the relinquishment agreement must be signed before project corridor approval is presented to the **Highway Commission** (See Section 7.E of this chapter).

Corridor protection for projects on existing alignment will generally consist of a 300-foot-wide strip on both sides of the existing right-of-way. For projects on a new alignment a strip usually 400 feet in width on both sides of the proposed centerline will be designated for corridor protection. These widths are guidelines only and may vary depending on the terrain and roadway design standard. Applicable projects will have corridor protection procedures initiated after the project concept and alignment have been defined.

When a property owner files a preliminary subdivision plat or a request for a building permit in an area with corridor protection, the local zoning authority will inform the owner that **NDOT** has filed corridor protection and that the preliminary plat cannot be approved or that the permit cannot be issued until coordination with **NDOT** occurs. After receiving notification by the local authority, **NDOT** has two months to approve or deny the request. If **NDOT** denies the request, it has six months to negotiate and acquire the necessary right-of-way. If **NDOT** has not acquired the right-of-way within six months, the local authority can issue an approval of the preliminary subdivision plat or the building permit. For additional information about corridor protection see Nebraska Revised Statute 39-1311.02 (<https://nebraskalegislature.gov/laws/statutes.php?statute=39-1311.02>) and the Nebraska Dept. of Transportation Operating Instruction 60-9, "Corridor Protection" (Appendix B, "Selected NDOT Operating Instructions").

## 2.C Ownership Plans

Ownership Plans are created by **ROW Design** for projects that require new right-of-way. Ownership Plans depict preliminary survey, topography, current ownerships, property lines, and previous right-of-way in the area of the project. Ownership Plans will be prepared prior to the plan-in-hand activity during “Roadway Design” for New and Reconstructed projects (Activity 5300, Clarity Task 5350) (See the Design Process Outline (DPO), Ref. 15.2) (<https://dot.nebraska.gov/business-center/design-consultant/>). For Resurfacing, Restoration and Rehabilitation (3R) projects Ownership Plans may be delayed until right-of-way needs are more clearly determined.

The following items are used in the creation of Ownership Plans:

- The sheet files from **Roadway Design** provide the base plan layout (the roadway designer will coordinate the base plan layout with **ROW Design** at Meeting “A”, see the CADD Policy, <https://dot.nebraska.gov/business-center/design-consultant/>)
- The right-of-way survey (provides section corners, quarter-section corners, and lot corners)
- Title research by **ROW** (provides a five-year record of property ownership)
- Previous right-of-way and controlled access (provided by reviewing old plans, deeds, railroad maps, railroad leases, and city plats)

These plans may be available for use in public meetings.

## 2.D Preliminary Right-of-Way Plans

The roadway designer notifies **ROW Design** of the availability of the limits of construction (LOCs) from “Design L.O.C.s to ROW” (Activity 5300, Clarity Task 5389). The LOCs denote the extent of grading, culvert extensions, channel changes, driveways, sidewalks, retaining walls, removal of improvements, channel changes, environmental mitigation requirements, and any other construction items. LOCs may be shown for items which may require right-of-way or easements, either permanent or temporary. Examples of such items include temporary roads, channel cleanouts, public frontage roads, private drives, joint use drives, or removal of improvements.

The LOCs are added to the Ownership Plans and right-of-way is designed, along with permanent and/or temporary easements, permanent and/or temporary railroad easements, and rights of entry or occupation as needed.

The roadway designer will notify **ROW Design** when the following items are available:

- Typical sections
- Environmental or Aerial (E) sheets (See Chapter Eleven: Highway Plans Assembly, Section 4.E, of this manual)
- Roadway Design Details (Activity 5500, Clarity Task 5508) (See the *DPO*, Ref. 15.2)
- Roadway cross-sections
- Culvert cross-sections
- Access Control letter, if applicable (See Section 3 of this chapter)
- Discussions between **Roadway Design** and property owners regarding their tract (e.g. right-of-way taking, potential impacts)
- Do not disturb areas (Do Not Disturb notes will be coordinated between **Roadway Design** and **ROW**)

### 2.D.1 Right-of-Way Design

Right-of-way will generally be designed based on the need for and use of the tract of land (the construction, operation, and/or maintenance of the project). For additional information see Section 2.07B: Determination of Right of Way Boundaries and Types, of the Right-of-Way Design Manual (Ref. 15.1).

### 2.D.2 Permanent Easements

Permanent easements allow **NDOT** permanent access to land for specific purposes while the ownership of the land remains in private hands. A permanent easement is attached to the property deed and **NDOT** retains permanent easement rights through any subsequent changes in ownership. Permanent easements are often used in lieu of purchasing land for right-of-way when it is beneficial for the property owner to retain some rights in the acquisition and it does not inhibit **NDOT's** ability to construct, operate, and maintain the highway. Purchasing land for right-of-way should always be preferred however permanent easements may be considered when the benefits of a permanent easement over a land purchase can be determined. Examples of when permanent easements could be used include:

- For areas on one property that are used to provide access to other properties
- For areas that are occasionally or permanently affected by drainage
- To permanently allow **NDOT** access for maintenance
- For areas needed to fulfill environmental permit requirements (e.g. channel changes, buffer zones, access to wetland mitigation sites)
- To minimize impacts on the adjacent property
- For any other areas that are permanently needed for a specific purpose

### 2.D.3 Temporary Easements

Temporary easements grant **NDOT** the right to use private property for a specific time period and when the time period expires the right reverts to the property owners. Temporary easements are used to permit the use of a specified area by the contractor while building the road improvement. Examples of when temporary easements are used include:

- The construction or reconstruction of a private drive
- Access to an area during construction
- Temporary roads to accommodate traffic during construction
- Crossing rights on Bureau of Reclamation property
- Areas needed to accommodate construction equipment and/or materials
- Areas needed to remove structures and/or improvements
- Culvert, channel, and/or ditch cleanout
- Areas needed to facilitate grading operations
- Shaping (e.g. to blend in fill or cut in urban areas where the slope is 1:4 or flatter)
- Borrow pit or excess material disposal
- Building sewers or inlets that drain water from private property (e.g. an inlet in a private parking lot)
- Any other areas that are temporarily needed to facilitate construction

#### 2.D.4 Railroad Easements, Rights, or Leases

NDOT normally does not acquire land from railroads as right-of-way. Land required at crossings or which is parallel to the highway will normally be acquired in the form of an easement and right of entry. Railroads will typically not grant permanent property rights for roadways running parallel to the railroad, parallel property rights with the railroad will only be pursued after significant coordination with the **Local Assistance Division's Highway Liaison Manager** and **ROW** and may be refused by the railroad. Highway crossings of the railroad may require additional coordination with the **Highway Liaison Manager** and **ROW** to ensure that **NDOT** has the necessary property rights for occupying the railroad's right-of-way.

#### 2.D.5 ROW Design Review

When the preliminary right-of-way design has been finished the right-of-way designer will notify the **Roadway Design Unit Head (Unit Head)** that it is available for review and coordination. **ROW Design** then schedules a "R.O.W. Review Meeting" (Activity 5600, Clarity Task 5610) to coordinate the right-of-way design and to identify potential right-of-way impacts (See the *DPO*, Ref. 15.2). After this meeting, the Appraisal Plans are prepared.

#### 2.D.6 Preliminary ROW Estimate

The **Chief Appraiser** of **ROW** will perform a preliminary estimate of the right-of-way costs prior to the appraisal of the project.

#### 2.E Appraisal Plans

The Appraisal Plans are used to initiate the **ROW** appraisal and acquisition process and should be representative of the proposed right-of-way acquisitions needed for construction. The **ROW Appraisal Section (Appraisal)**, **PDD**, the **Utility Unit in Roadway Design (Utilities)**, and the **Rail Unit** in the **Local Assistance Division** use the Appraisal Plans. The appraiser may request a plan review with the roadway designer using the Appraisal Plans. The roadway designer should not change the alignment after the Appraisal Plan stage.

#### 2.F Negotiation Plans

Negotiation Plans reflect changes made to the Appraisal Plans as a result of the appraisal process. **Right-of-Way Negotiators** use Negotiation Plans to explain the offers to purchase right-of-way to landowners. If an agreement cannot be reached with a landowner on payment, the **State of Nebraska (State)** will file a condemnation to acquire the right-of-way. Right-of-way required for the project will either be acquired and paid for or condemned and paid for prior to advertising a project for bid letting.

## 2.G PS&E Plans

**ROW Design** will place the right-of-way plans in ProjectWise for use by **PDU**. When the roadway designer is ready to submit the Plans Package to the **Construction Division Plans, Specifications and Estimates Unit (PS&E)** for review (Activity 5700, Clarity Task 5790), he/she should obtain a Right-of-Way Certificate (**ROW Clarity Task 5666**) from the **Property Management Unit of ROW** (See Section 6 of this chapter). Changes/revisions to the right-of-way plans following submittal to **PS&E** will be coordinated with the **District, Roadway Design, PS&E, Utilities**, and any other **Divisions/Units** impacted by the revision.

## 2.H Plan Changes/Revisions

Changes to right-of-way plans may be made during any stage of development but most often occur during the appraisal and negotiation stages. The individual requesting a plan change or revision will notify the **ROW Design Engineer** and/or **Roadway Design** of possible conflict and project concerns. The appraiser or negotiator will also report specific suggestions or questions from the landowner and will ask the designer to review and, if practicable, change the design related to the questions. Some change requests and/or revisions may also be brought to **Roadway Design** through the **DE**. Requests from the roadway designer for right-of-way plan changes/revisions must be documented in the project file. Requests for plan changes/revisions will be sent to the **ROW Design Engineer** through the **Unit Head**. Plan changes occurring after the project has been advertised will be processed as a plan revision as outlined in Chapter Eleven: Highway Plans Assembly, Section 7.



### 3. ACCESS CONTROL

Access control is a restriction of the number and location of access points (intersections, driveways, and field entrances) along a highway. Access control along a highway reduces interruptions in the traffic flow, increasing the efficiency of the facility. Access rights will typically be acquired on:

- Interstates
- Freeways
- Expressways and other multi-lane divided highways

Access control will be considered on other highways when:

- The 20-year forecast traffic (ADT) is 3,001 or greater, as shown on the current 20 Year Forecast Traffic Map (<https://dot.nebraska.gov/travel/map-library/>)
- The route is within the present or projected two-mile zoning limits of cities of the first class (population 5,000 to 99,999) and within the present or projected three-mile zoning limits of primary (population 100,000 to 299,999) and metropolitan (population more than 300,000) class cities
- There are three miles or less between the Interstate and the connecting or parallel highway
- The development of a major highway, particularly where mobility is important

The degree of access control should be balanced between three essential public functions:

- Access to property
- Travel mobility
- Motorist safety

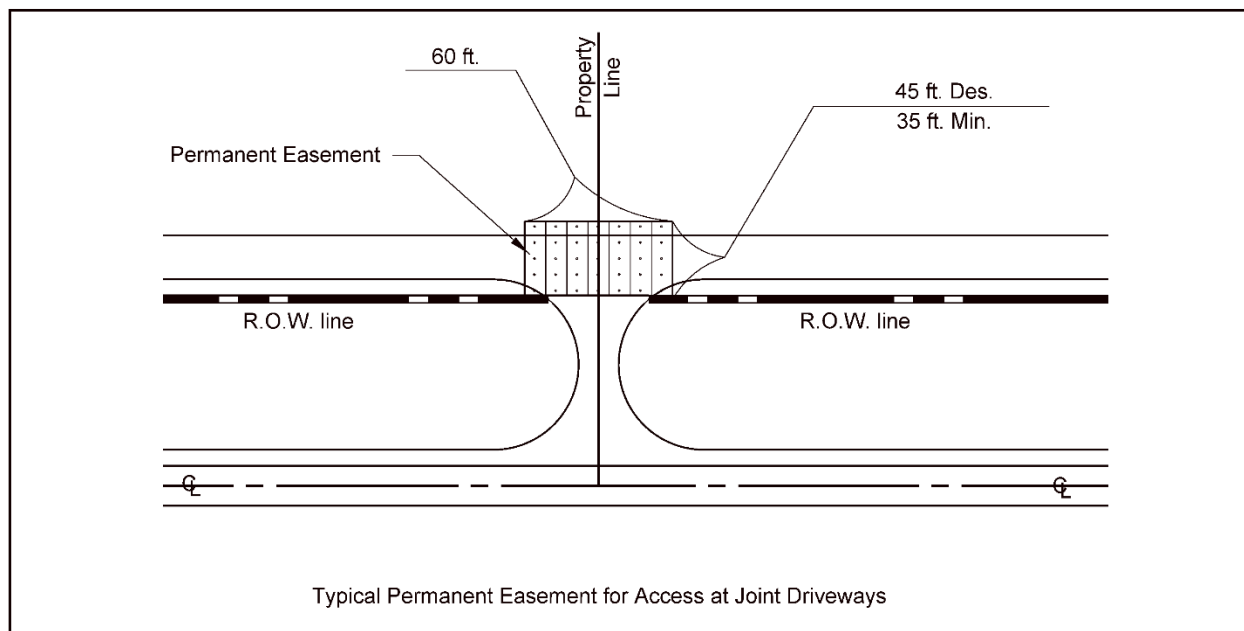
As authorized by the Nebraska Revised Statutes, Chapter 39-1327 (Ref. 15.4) (<https://nebraskalegislature.gov/laws/statutes.php?statute=39-1327&print=true>) **NDOT** may acquire, in public or private property, such rights of access as are deemed necessary including but not necessarily limited to air, light, view, egress, and ingress. The **State** cannot condemn property from one owner to provide access to property for another owner if the owner to be served by the access already has another access to his/her property. This is the case no matter how inconvenient the existing access may be or if the existing access is only a right-in, right-out situation because of median restrictions.

For additional information on access control and on the access control project review procedure, refer to the Access Control Policy to the State Highway System (Ref. 15.5) (<https://dot.nebraska.gov/media/v45nhanu/access-control-policy.pdf>).

### 3.A Access Control Design

There are currently two types of driveway classification: access and future access (access locations identified but not built as part of the highway project will be designated as future access). Access should be provided for each property along a project to allow for possible future development.

At the time that the access points are designed, existing entrances may be removed or relocated to connect to the designed access locations as a part of the highway project. Access control may need to be acquired for an urban tract where an existing driveway is closed. **NDOT** will be responsible for constructing the entrances at the designed access locations as a part of the project. **NDOT** will not construct the access locations referred to as future access. Driveways which serve multiple properties will be classified as "joint drives". [EXHIBIT 15.1](#) is an example of the typical permanent easement acquired for a driveway serving multiple properties.



**Exhibit 15.1 Typical Access Control at Joint Driveways**

The roadway designer will designate access locations for a project during "Roadway Design" (Activity 5300, Clarity Task 5350) (See the *DPO*, Ref. 15.2). Information used in determining access locations includes:

1. Obtaining relevant information from the **DE** and others
2. Reviewing the zoning, existing, and future land use
3. Conducting a field examination
4. Considering intersection sight distance, natural barriers, property lines, the development of future frontage roads, and traffic signal spacing

Property adjacent to the highway project must be permitted access to a public road unless the project results in the highway bordering property that previously did not have direct egress and ingress to the highway. If a parcel is "landlocked", and access is not practicable, the parcel may be purchased as part of right-of-way acquisition.

Items to consider when a roadway has existing controlled access and access is being revised as part of a current project include:

- When providing an unrestricted access to a property that previously had restricted access, the property may be considered as enhanced. The potential for enhancement will be considered during appraisal. Typically, **NDOT** has no obligation to provide access rights other than what presently exists. A decision to provide enhanced access should be justified.
- When access is restricted to a property that previously had unrestricted access, it is likely that the value of the property has changed. **NDOT** appraisers will consider these factors during the appraisal process.

Once the roadway designer is prepared to make recommendations about acquiring access control, the roadway designer should contact the **Property Management Section** of **ROW** and request to be placed on the agenda for the next available access control meeting. The roadway designer will present recommendations for or against acquiring access rights to the **Access Control Team** and must be able to support the recommendations. The roadway designer's presentation should include an aerial photo showing property lines and the access locations which meet the Access Control Policy to the State Highway System (Ref. 15.5) for the **Access Control Team's** review and approval.

At the meeting, the **Access Control Team** will review the project as part of the functional design review to determine access control. The **Access Control Team's** decision is based on many factors, including the following:

- Traffic counts
- Highway classification
- Safety of persons using the highway
- Preservation of the public's investment in the existing highway
- Effect of vehicles using the access point on the traffic-carrying capability of the highway
- Existing sight distance
- Highway alignment and configuration
- Volume and speed of traffic on the highway at the proposed access point
- Traffic volumes generated by the development served by the access and the extent to which improvement to the highway facilities by the persons requesting access will mitigate the adverse effects caused by the access point to the highway
- Closure or relocation of existing access points
- Moving the new access to a property line for a joint-use drive
- Conformance of proposed development to zoning regulations
- Dedication of right-of-way for future public streets to provide for the orderly development of the property abutting the highway

The roadway designer will be responsible for preparing the CA (control access) Letter, which indicates the decisions made by the **Access Control Team** (See EXHIBIT 15.2).



Pete Ricketts, Governor

**DATE:** September 28, 2015  
**TO:** Project File  
**FROM:** Consulting Firm Representative \_\_\_\_\_  
**THRU:** NDOT Consultant Coordinator \_\_\_\_\_ NDOT Assistant Design Engineer \_\_\_\_\_  
**SUBJECT:** Access Control  
 Project S 30-6(1046), US Schuyler to Rogers, C.N. 32033

Access Control for the above mentioned project was reviewed on August 23, 2017. A small amount of existing controlled access is summarized below. Access control will be acquired for US-30 as part of this project, except as noted below. Access control will be acquired for 220 ft. along intersecting public roads, except as noted below on County Road 15. This distance shall be measured from the closest edge of the nearest through lane.

Existing controlled access was documented in the following locations:

- Project 30-6(126), Schuyler East & West, Station 300+50 to 313+23, left and right.
- Project F-213(3) Station 576+93 to 584+24, right, within a segment of US-30 that will be relinquished near Rogers, NE.

**CA on County Roads**

Sta. 339+62.05	County Road 14	220' on both sides of County Road 14
Sta. 392+34.88	County Road 15	220' on south side of County Road 15 203' on north side to line up with existing driveway to east
Sta. 444+50.00	County Road 16	220' on both sides of County Road 16
Sta. 497+85.00	County Road 17	220' on both sides of County Road 17
Sta. 550+37.11	County Road 18	220' on both sides of County Road 18
Sta. 576+94.03	Center Street	220' on both sides of Center Street South
Sta. 603+66.70	County Road 19	220' on both sides of County Road 19 North

Kyle Schneweis, P.E., Director  
 Department of Transportation  
 1500 Highway 2  
 PO Box 94759  
 Lincoln, NE 68509-4759  
[dot.nebraska.gov](http://dot.nebraska.gov)

OFFICE 402-471-4567 FAX 402-479-4325  
 NDOT.ContactUs@nebraska.gov

C.N. 32033  
 September 28, 2015  
 Page 2

Drives

Main line	Side	Type	Notes
319+80	LT	Existing Farm Drive	Existing drive relocated 175' east
319+80	RT		New Access Location, Joint Field Entrance
318+37.71	RT	Existing Field Entrance	Close (move to 318+00)
326+32.94	RT	Existing Field Entrance	Close (move to 318+00)
341+45.44	LT	Existing Drive	Close (move to County Road 14)
342+45.04	LT	Existing Drive	Close (move to County Road 14)
342+76.80	RT	Existing Drive	Close (move to County Road 14)
343+76.75	LT	Existing Field Entrance	Close (move to County Road 14)
346+26.63	RT	Existing Field Entrance	Close (move to Sta. 352+75)
352+77.14	LT	Joint Field Entrance	New Access Location
352+77.14	RT	Field Entrance	New Access Location
364+00	LT		New Access Location
364+00	RT		New Access Location
364+86.41	RT	Existing Field Entrance	Close (move to Sta 364+00)
375+49.10	LT	Existing Join Access/Drive	Keep Open
375+49.10	RT	Field Entrance	New Access Location
387+71.30	RT	Existing Drive	Close (move to County Road 15)
397+80.50	LT	Existing Entrance	Close (move to County Road 15)
397+87.43	LT	Existing Field Entrance	Close (move to County Road 15)
398+62.74	LT	Existing Farm Drive	Close (move to County Road 15)
418+00	LT	Existing Farm Entrance	Keep Open
418+00	RT	Existing Field Entrance	Keep open
431+46.07	LT	Existing Field Entrance	Close (move to County Road 16)
432+19.39	RT	Existing Field Entrance	Close (move to County Road 16)
444+72.74	RT	Existing Field Entrance	Close (move to County Road 16)
470+83.64	LT	Existing Field Entrance	Close
471+00	LT	Existing Joint Field Entrance	Keep Open, Slightly shifted east
471+00	RT	Existing Field Entrance	New Access Location
487+26.39	LT		New Access Location, Driveway
487+26.39	RT		New Access Location, Field Entrance
490+60.15	LT	Existing Farm Entrance	Close (move to Sta 487+25)
499+27.40	LT	Existing Farm Drive	Close (move to County Road 17)
504+35.86	LT	Existing Field Entrance	Close
517+99.97	RT	Existing Field Entrance	Close
523+99.38	LT	Existing Field Entrance	Keep Open, Slightly shifted west
523+99.38	RT		New Joint Access Location, Field Entrance
525+12.54	RT	Existing Field Entrance	Close (move to Sta 523+99.38)
548+33.58	LT	Existing Residential Entrance	Close (move to County Road 18)
576+94.18	LT		New joint access location, Field Entrance
590+14.56	LT	Existing farm drive/entrance	Keep Open
590+14.56	RT	Existing farm drive/entrance	Keep Open
603+62.10	RT	Existing Field Entrance	Keep Open
641+96.78	RT	Existing farm drive/entrance	Close (move to Sta 644+00). Coordinate Rogers to North Bend
644+00	LT		New Access Location. Coordinate Rogers to North Bend
644+00	RT	Existing Field Entrance	Keep Open. Joint Access. Coordinate Rogers to North Bend

Other Items that were discussed:

Locations along US-30 provide access to wells/pivots and new/relocated accesses are proposed some distance away possibly making it more difficult to access wells/pivots (Example: 505+00 Lt is moving to 524+00 Lt). During PIH it was thought that several locations along the project were not access locations but a location where an owner drives down the foreslope / ditch to access wells.

CC:

- Project Development Division - Division Head
- District 3 Engineer
- Right of Way Division - R.O.W. Design Engineer
- Right of Way Division - Property Management
- Right of Way Division - Chief Appraiser
- FHWA
- Consultant

**Exhibit 15.2 Example Control Access Letter (Continued)**

### **3.B Access Control on the Interstate, Freeways and Expressways (Access Only at Interchanges)**

The Interstate, freeway and expressway (access only at interchanges) systems are multi-lane highways for through traffic with full control of access and no at-grade intersections. Access to the facility is allowed only at interchange locations. Access control should typically be acquired a minimum of 660 feet beyond the interchange ramp terminal (See [EXHIBIT 15.4](#)).

### **3.C Access Control on Expressways and Other Four-Lane Divided Highways**

An expressway highway is, or will ultimately be, a four-lane divided highway with full or partial control of access, with interchanges at major intersections, and at-grade intersections at designated minor public road intersections.

Selected public road intersections will be permitted at-grade. At-grade access from abutting property to the expressway at approved points will also be considered and allowed as noted in the [Access Control Policy to the State Highway System](#) (Ref. 15.5). See [EXHIBIT 15.3](#) for access spacing.

The desirable access spacing for expressways in developed urban areas should consolidate access locations. Access locations should be no closer than two blocks. The maximum allowable access spacing should also consolidate access locations and may match the existing street system and/or development. If possible, an access location on one side of the highway should be located opposite the access on the other side of the highway.

### **3.D Access Control on Other Highways**

In rural areas the spacing of access locations on other access controlled highways will take into consideration access to the property involved, including that from adjacent county roads or streets. Access locations required to provide reasonable access will be provided by **NDOT** (See [EXHIBIT 15.3](#)).

An effort should be made to consolidate access locations. When consolidating access locations, driveways on one side of the highway should be located opposite the driveways on the other side. Future access openings should be provided for each property, where warranted, to allow for possible future development.

Rural rules apply in undeveloped urban areas. In developed urban areas an effort will be made to consolidate access locations. Future access openings should be provided for each property, where warranted, to allow for possible future development.

### 3.E Access Control on Side Streets and Roads

On projects that include the purchase of access control, access points along intercepting public roads and highways will be located a sufficient distance from the intersection to avoid conflicts and to improve the efficiency of the highway intersection. Access control will be extended along these intercepting roads so that the proper distance from the intersection remains clear of intersections, driveways, and field entrances.

Access control will be purchased for a minimum distance of 220 feet along intercepting public roads and for 660 feet along intercepting highways (See [EXHIBIT 15.5](#)). To account for multiple through lanes, turning lanes, and variable median widths this distance will be measured from the closest edge of the nearest through lane of the mainline (See [EXHIBIT 15.6](#)). **Roadway Design** will calculate these distances in relation to the project centerline and provide the necessary information to **ROW Design** for the design of the access control.

Skewed intersections will have the access control measured along the centerline of the intersecting roadway from the closest edge of the nearest through lane of the mainline (See [EXHIBIT 15.7](#)). The access control limits will be offset to left and/or right of the intercepting road at this station. Intersections of greater than 15° skew should be evaluated on a case by case basis to determine if the minimum distances should be increased to maintain the integrity of the intersection.

Drives and field entrances along the intercepting roadway should be placed so that the driveway throat is beyond the access control limits. Exceptions to this policy must have approval of the **Access Control Team**.

Specific or unusual intersections will be evaluated on a case-by-case basis, with recommendations brought before the **Access Control Team** for approval.

### 3.F Public Notification

If access control is being purchased a public meeting should be considered. If held, the public meeting will follow the normal public notification and public hearing process. This meeting should be coordinated with **ROW**.

The Nebraska Revised Statutes, Chapter 39-1327 (Ref. 15.4), states that projects which establish access control on any segment of a project will require the written advice of the **State Highway Commission** and the consent of the **Governor**. A Highway Commission Statement will be prepared for projects that include new access control.

There are instances when, even though access control is not changed, access to individual properties may be affected, such as when islands are installed. When access is changed a public meeting is not usually required, it is sufficient to inform the impacted property owners of the changes.

<b>Table I</b>				
<b>Expressway and Other Multi-lane Divided Highways Including Non-Multi-lane Highways with future ADT over 6000</b>				
<b>Area Type</b>	<b>Desirable Access</b>		<b>Maximum Allowable Access*</b>	
	<b>Number of Access Locations per Mile</b>	<b>Spacing Between Access Pts.</b>	<b>Number of Access Locations per Mile</b>	<b>Minimum Spacing Between Access Points</b>
<b>Rural and Undeveloped Urban</b>	1	2,000 feet	3	1,000 feet
<b>Developed Urban</b>	Consider consolidation of drives	2 blocks	Consider consolidation of drives	Consider street system and/or development

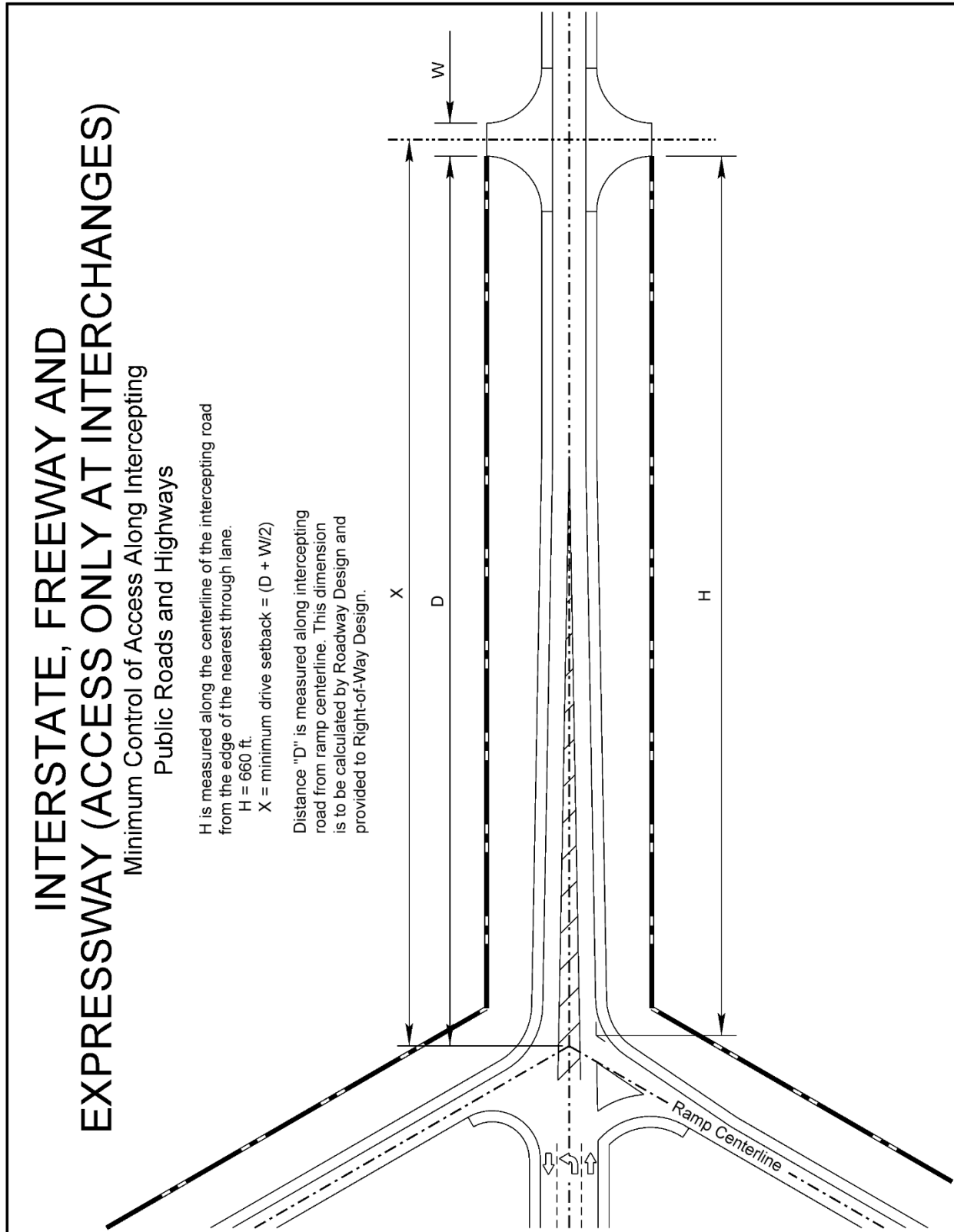
\* Maximum allowable access is no more than three access locations per mile with 1000 feet as the minimum distance between access locations. Minimum spacing should only be used for access to developed properties such as occupied farmsteads, residences, businesses, and land-locked parcels.

<b>Table II</b>				
<b>Other Controlled Highways</b>				
<b>Area Type</b>	<b>Desirable Access</b>		<b>Maximum Allowable Access</b>	
	<b>Number of Access Locations per Mile</b>	<b>Spacing Between Access Points</b>	<b>Number of Access Locations per Mile</b>	<b>Minimum Spacing Between Access Points</b>
<b>Rural and Undeveloped Urban</b>	3**	1,000 feet	Provide access to all properties **	Consider consolidation of drives
<b>Undeveloped Urban</b>	7**	600 feet	Provide access to all properties **	Consider consolidation of drives
<b>Urban</b>	Provide access to all properties **	Consider consolidation of drives	Provide access to all properties **	Consider consolidation of drives

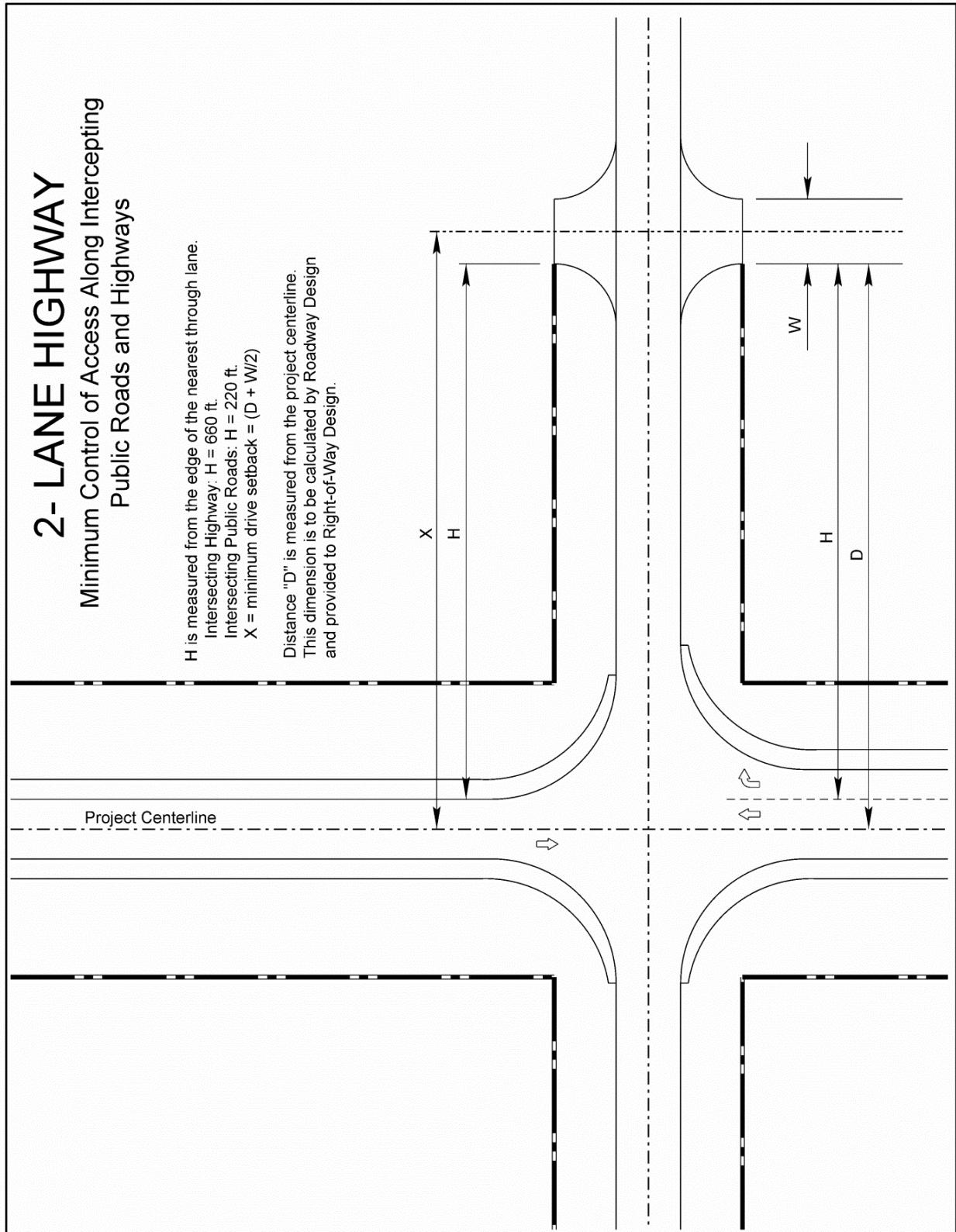
\*\* Future access openings should provide for each property, where warranted, to provide for possible future development.

**Exhibit 15.3 Desirable and Minimum Access Locations**

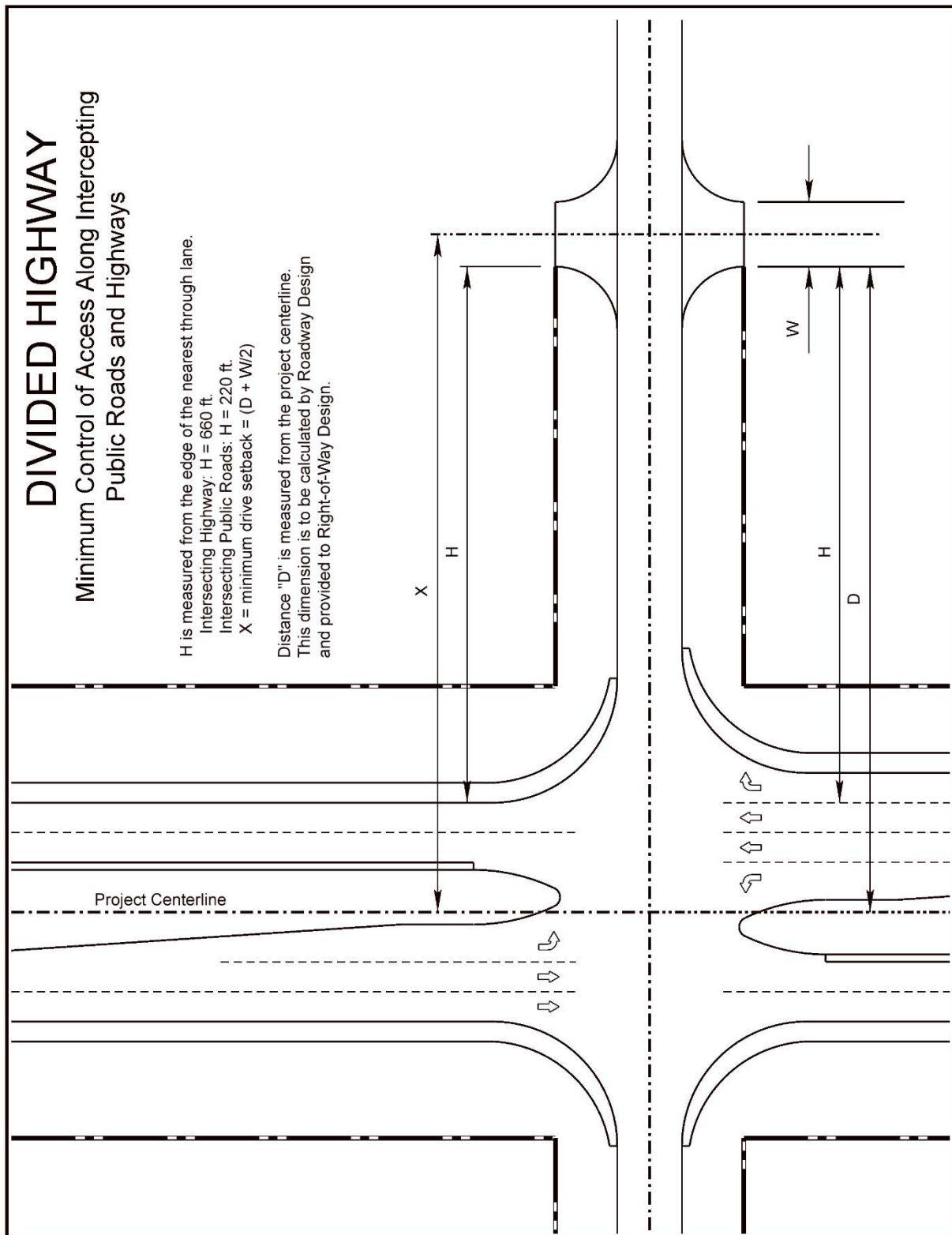




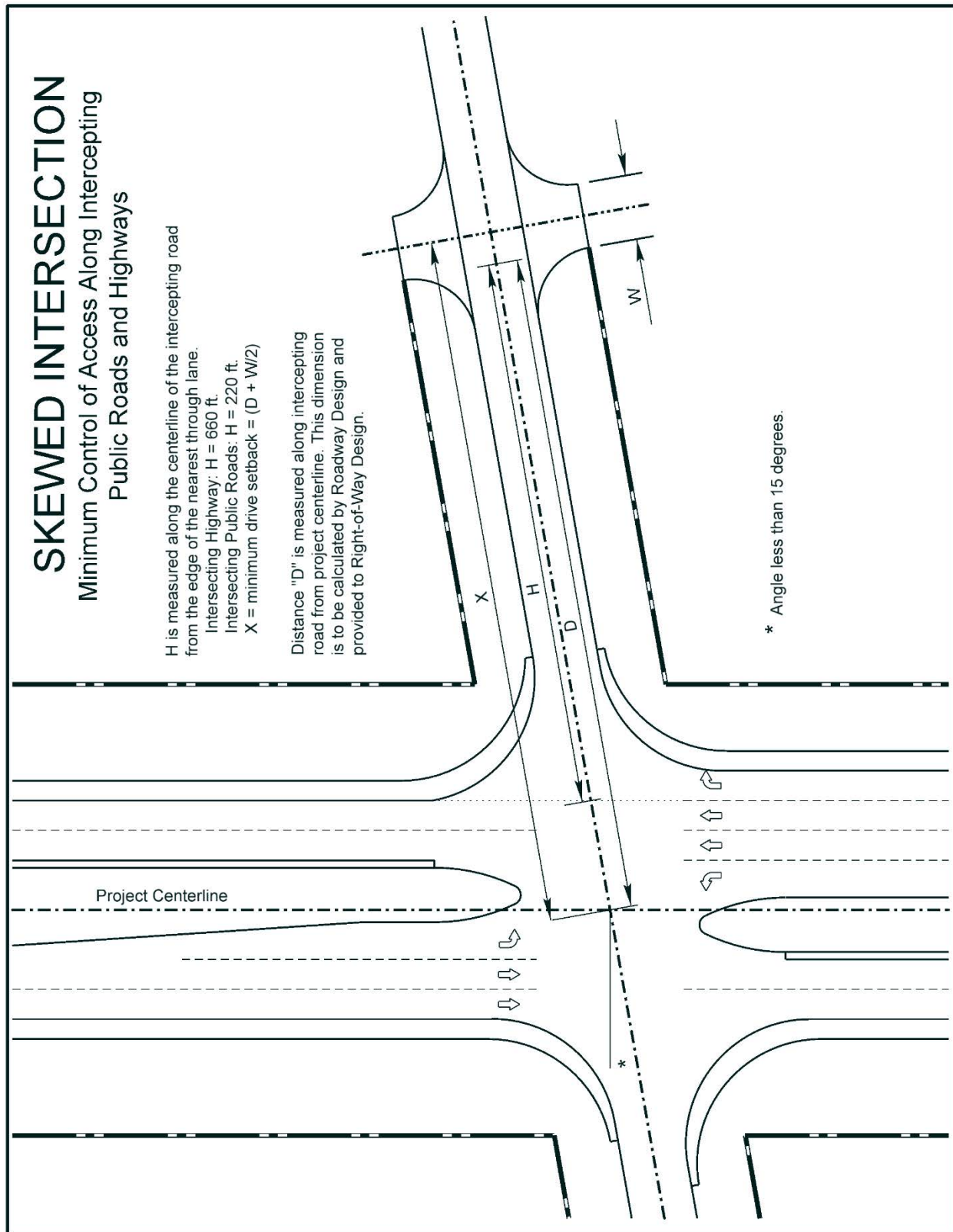
**Exhibit 15.4 Control of Access Along Intercepting Public Roads and Highways Interstate, Freeway and Expressway (Access only at Interchanges)**



**Exhibit 15.5 Control of Access Along Intercepting Public Roads and Highways  
 2-Lane Highway**



**Exhibit 15.6 Control of Access Along Intercepting Public Roads and Highways  
Divided Highway**



**Exhibit 15.7 Control of Access Along Intercepting Public Roads and Highways Skewed Intersection**

#### 4. APPRAISAL

Right-of-way appraisal begins with the Appraisal Plan distribution; appraisers may request a pre-appraisal meeting with the roadway designer to discuss the project. On some projects **Roadway Design** will hold a Public Information Meeting prior to appraisal and acquisition which may be attended by appraisers from **ROW**. This is a meeting to present project information, preliminary right-of-way needs, and the appraisal and negotiation process to the public. Public input and suggestions will be reviewed for consideration.

Following this Public Information Meeting, if held, the appraisal process begins. Appraisers generally meet with landowners where the acquisition and property damages are estimated to be more than an established dollar amount. Appraisers will notify the roadway designer and/or the right-of-way designer of questions, concerns, or suggestions from the landowners.

#### 5. ACQUISITION

**ROW Negotiators** may request a pre-negotiation meeting with the roadway designer to discuss the project at this time. The Pre-Negotiation meeting is the opportunity for the **ROW Negotiator** to gain an understanding of the roadway design details, any commitments the roadway designer has made, receive a description of the project phasing, and any background information the **ROW Negotiator** will need to be successful. Attendance by the roadway designer and their **Unit Head** is required. The right-of-way agent will contact property owners in person or by mail when property is to be acquired.

##### 5.A Contract Preparation

After appraisals have been prepared and reviewed, they are sent to the **ROW Negotiation Section**. Contracts are prepared showing itemized descriptions of the property to be acquired and the dollar value associated with each item. When the contracts to purchase and legal instruments to file are prepared, the **Negotiation Section** notifies **ROW Design**. **ROW Design** makes the necessary changes and sends out "tentative final" Negotiation Plans.

##### 5.B Condemnation

If the **State** and the landowner cannot agree on a settlement amount the negotiator will notify the **Chief Negotiator**. The **Chief Negotiator** will request a condemnation plat from **ROW Design**.

##### 5.C Relocation Assistance

A person or business displaced by a construction project is eligible to participate in the Relocation Assistance Program. This program is designed to help pay the expenses for relocating residential occupants, businesses, farm/ranch buildings, and non-profit organizations if they are displaced because of a highway improvement. For additional information see Chapter Seven of the Right-of-Way Manual (Ref. 15.1).

## 6. RIGHT-OF-WAY CERTIFICATION

Prior to the advertising of the letting date of a project, **ROW** will furnish a certificate stating either that the right-of-way is available to the contractor and clear of improvements or stating the estimated date when the right-of-way will be clear and available. The **Property Management Supervisor** will furnish the Right-of-Way Certificate, which will be signed by the **Right-of-Way Manager**. This certificate is sent to **Roadway Design**, and on PS&E Risk Based Projects (RBPs) and federally funded projects the **Construction Division** will transmit a certificate to **FHWA**.

**ROW Design** should provide the roadway designer with a listing of removal items which will appear on the Right-of-Way Certificate (**ROW** Clarity Task 5666) during the Review Appraisal Process, approximately three months prior the project letting.

### 6.A Public Interest Letters

The right-of-way should be acquired prior to the project letting date but sometimes right-of-way acquisition is delayed (e.g. through condemnation proceedings). To maintain construction schedules for projects on the NHS it is sometimes necessary to request special exception from **FHWA** on federally funded projects to proceed with the scheduled letting dates. This request should be in the form of a Public Interest Letter (PIL) (See [EXHIBIT 15.8](#)) that includes:

- Information about the project
- The status of right-of-way acquisitions
- How would construction proceed based on the limited right-of-way availability
- The benefit/cost to the public

This PIL shall conform to the requirements of Title 23 CFR 635.309 <https://www.govinfo.gov/content/pkg/CFR-2005-title23-vol1/pdf/CFR-2005-title23-vol1-sec635-309.pdf> and a "Memorandum of Understanding" with **FHWA** (See Appendix C, "Public Interest Letters"). It is very important that the pertinent information be included in this request to avoid additional delay and the letter should assert that one of the following conditions pertains to the project.

1. Although full legal possession of all necessary rights-of-way have not been acquired, the right of entry to and occupation of the property for the construction of the project has been obtained.
2. The acquisition or right of occupancy and use of a few parcels on the project is not complete but all occupants have had replacement housing made available. This request should only be made by **NDOT** under unusual circumstances. Work may be authorized if **FHWA** finds that it will be in the public interest.

The roadway designer should contact **ROW Negotiation** for the latest right-of-way status. Roadway designers should use this report when developing a PIL. Upon completion of the PIL:

1. The **Assistant Design Engineer (ADE)** will coordinate the PIL with **FHWA** and then send the PIL, through the **Roadway Design Engineer**, to the **Deputy-Director of Engineering** for approval (with a cc to the **Program Management Engineer**).
2. When the letter has been approved by the **Deputy-Director of Engineering** and **FHWA**, the **Deputy-Director of Engineering** will notify the **Roadway Design Engineer**, with a cc to:
  - The **Highway Contracts Manager**
  - The **ADE**
  - The **Program Management Engineer**
  - The **DE**
  - The **District Construction Engineer (DCE)**
  - The **Right-of-Way Manager**

Under the terms of the current **FHWA Nebraska Division** guidance, **NDOT** has approval authority for RBP projects which are not on the NHS. If a RBP project which is not on the NHS requires a PIL, a copy of the PIL will be sent to **FHWA** for information only (See Chapter One: Roadway Design Standards, Section 10.A.2, of this manual).

The same procedure as outlined above will be followed for a PIL on a project which is neither on the NHS or RBP, with the exception that **FHWA** coordination and approval will not be required.



Pete Ricketts, Governor

July 31, 2017

Deputy Director – Engineering  
Nebraska Department of Transportation  
1500 Highway 2  
Lincoln, NE 68509-4759

RE: Project No. S-6-3(1026); CN 71059; US-6/34 & US-183 East & West, Holdrege  
Project No. MISC-6-3(1030); CN 71059A; Sidewalk Vaults in Holdrege

Dear Deputy Director:

We request authorization to let the above-mentioned projects on August 31, 2017. This would accelerate the letting of Project S-6-3(1026) from the current scheduled letting on October 5, 2017 in order to hard tie this project to Project MISC-6-3(1030) US-6/34 Sidewalk Vaults in Holdrege (CN 71059a). The two projects overlap in the core business district in Holdrege. Letting both projects together in a single contract in August will enhance the coordination of work, lower the prospective bids, reduce the overall time to complete the work, and benefit the general public.

The property rights acquisitions for these projects includes 73 contracts on 47 tracts. As of today, 9 contracts on 9 tracts remain unsigned. The following describes the status of the remaining contracts to be acquired:

Tract 4 – NDOT met with the landowner on July 25, 2017. The landowner will discuss further with agent on July 31, 2017.

Tract 9L – NDOT's agent has not been able to make contact with this property owner. Contact was attempted on July 24 and July 25, 2017. Contact will be attempted again on July 31, 2017.

Tract 11 – NDOT's agent has not been able to make contact with this property owner. Contact was attempted on July 24 and July 25, 2017. Contact will be attempted again on July 31, 2017.

Tract 22 – The property owner's attorney is reviewing the documents. NDOT will be able to meet with owner's attorney July 27 or July 28, 2017.

Tract 23L (lessee) – Initial offer has been made with no indication of issues with offer. Meeting with lessee scheduled for July 27, 2017.

Tract 29 – Initial contact has been made. Follow-up contact will occur this week.

Tract 31 – Initial contact has been made. A meeting to discuss offer is scheduled July 27, 2017.

Tract 35 – The property owner has been contacted several times by email and phone and NDOT has been answering questions. NDOT will contact the owner July 27, 2017 to arrange time to obtain signatures.

Kyle Schneweis, P.E. Director  
Department of Transportation  
1500 Highway 2  
PO Box 94759  
Lincoln, NE 68509-4759  
[dot.nebraska.gov](http://dot.nebraska.gov)

OFFICE 402-471-4567 FAX 402-479-4325  
NDOT.ContactUs@nebraska.gov



Deputy Director - Engineering  
July 31, 2017  
Page 2

Tract 46L (lessee) – The offer packet has been mailed to lessee. Follow-up will be made by agent July 28, 2017.

Tract 46L is required for construction of Project MISC-6-3(1030). All other unsigned tracts are required for Project S-6-3(1026).

Ten day notice letters will be sent on August 1, 2017 for any of the contracts that remain unsigned on that date. If the contracts from the parties of the unsigned tracts are not received by August 11, 2017 condemnation proceedings will be initiated with those parties. This will provide time to acquire the land rights prior to the start of the vault construction currently scheduled for October 9, 2017 and for the roadway construction currently scheduled for March 26, 2018.

Project Details

Project S-6-3(1026) is a new and reconstruct project that will reconstruct 0.69 miles of US-6/34 located in Phelps County, beginning just west of the junction of US-6/34 and US-183 at mile marker (MM) 158+23, and extending east to approximately MM 158+90, just east of the East Avenue business center in Holdrege.

The improvements on this project comprise of removing the existing pavement consisting of asphalt, concrete, and brick, and reconstructing with 9-inch-thick, doweled concrete pavement on a foundation course with prepared subgrade. The project also includes installation of storm sewer, underdrains, sidewalks, curb ramps, lighting, traffic signals, and permanent pavement markings. Water main and sanitary sewer relocations will also be performed as a part of the project.

Moving the bid to August will allow us to tie the project bid to project MISC-6-3(1030) US-6/34 Sidewalk Vaults in Holdrege (CN 71059a). The Sidewalk Vault project will fill basements that extend under the sidewalk at two building locations along the project corridor and is being bid in August to allow time for the basement work to be completed prior to the roadway construction. This work is necessary for proper construction of the new roadway and storm sewer system being constructed under S-6-3(1026). Having the two projects tied for bid will greatly enhance the project coordination by having all the work performed under one general contractor.

Additionally, letting the project in August provides the best opportunity to receive lower bids as contractors try to line up work for the following construction season. Bid prices typically rise as bid lettings get closer to the construction season and contractor's workloads become established.

Therefore, I believe it to be in the public's interest to let this project in the August 31, 2017 letting because of the benefits described above. I request approval of this Public Interest Letter under the condition that NDOR will not allow the contractor to perform work on the unsecured tracts until legal and physical possession of them have been obtained. The contractor will be informed of the right-of-way status and our requirements through the bid proposal.

Sincerely,

\_\_\_\_\_  
Roadway Design Engineer

Approved by:

\_\_\_\_\_  
Deputy Director - Engineering

Attachments: Location Map

xc: Project File  
Highway Contracts Manager  
Assistant Design Engineer  
Program Management Engineer

District 7 Engineer  
District 7 Construction Engineer  
Right of Way Division Manager

## 7. MISCELLANEOUS

### 7.A Right-of-Way Markers

Right-of-way markers will be required on most projects. One marker should be set at each of the following points:

- At each point where the right-of-way width changes
- At each PC and PT
- At each PI without a curve
- At such other points required to accurately delineate the right-of-way, but not less than 20 per mile (10 per mile per side)

Where it is undesirable to set right-of-way markers, such as on lot or block lines in an urban area, the markers will be omitted and authorized **NDOT** personnel will place iron pipes or pins. Markers should be located so that it is possible for a person standing at one marker to see either adjacent marker. On projects where the existing right-of-way will be altered the existing markers should be reset. The summary of quantities should separately identify the quantities of new markers and markers to be reset.

### 7.B Re-establishing Land Monuments and Property Corners

When construction disturbs or threatens to disturb existing land monuments or lot corners, and when requested by the landowner or **DE**, the new lot corners and the new right-of-way breaks will be re-established under the construction contract by a licensed land surveyor hired by the contractor. This work will consist of establishing new right-of-way breaks where **NDOT** has purchased additional right-of-way and re-establishing property corners on the new right-of-way line where, through work that occurred in the area, the monuments were destroyed.

### 7.C Fencing

See Chapter Ten: Miscellaneous Design Issues, Section 6, of this manual.

## 7.D Relinquishment and Abandonment

When a segment of highway is relocated the functional classification of the old highway will be changed. **NDOT** shall offer to relinquish to the political or governmental subdivision(s) or public corporation(s) the portion of the old state highway that has been relocated. **NDOT** will relinquish the highway to the local agency after following the approved policy for relinquishment of highways. If an offer to relinquish a highway segment is not accepted by the local jurisdiction(s), the **State** may abandon it as provided by law. Properties shall not be land-locked; access to properties must be preserved.

Before the highway is relinquished the surfacing will be brought up to the minimum standards of its new functional classification (city street, county road, etc.), if necessary. The roadway designer has the responsibility of producing the necessary plans and estimates for any upgrades which are required before relinquishment and has the responsibility for the preparation of the exhibits for the public hearing and of the agreements with the local government(s) regarding the relinquishments.

Early acceptance by the local government is important. A signed Covenant Relinquishment Agreement is required before the public hearing. If a public hearing is not held, the signed agreement and petition are needed before presenting the project to the **Highway Commission** for location approval.

For additional information see Dept. of Transportation Operating Instruction 60-13, "Relinquishment of Roads from the Highway System" (Appendix B, "Selected NDOT Operating Instructions"), Nebraska Revised Statutes, Chapter 39-1313 (Ref. 15.7) (<https://nebraskalegislature.gov/laws/statutes.php?statute=39-1313>) Nebraska Revised Statutes, Chapter 39-1314 (Ref. 15.8) (<https://nebraskalegislature.gov/laws/statutes.php?statute=39-1314>) and Nebraska Revised Statutes, Chapter 39-1315 (Ref. 15.9) (<https://nebraskalegislature.gov/laws/statutes.php?statute=39-1315>).

## 8. REFERENCES

- 15.1 Nebraska Department of Transportation, Right-of-Way Manual, Current Edition. (<https://dot.nebraska.gov/media/0sopjmah/row-manual.pdf>)
- 15.2 Nebraska Department of Transportation, Design Process Outline (DPO), Current Edition. (<https://dot.nebraska.gov/business-center/design-consultant/>)
- 15.3 Board of Public Roads Classifications and Standards, Nebraska Minimum Design Standards (MDS), Current Edition. (<https://dot.nebraska.gov/media/1z1n5kmb/nac-428-rules-regs-nbcs.pdf>)
- 15.4 Nebraska Revised Statutes, Chapter 39-1327 (<https://nebraskalegislature.gov/laws/statutes.php?statute=39-1327&print=true>)
- 15.5 Nebraska Department of Transportation, Access Control Policy to the State Highway System, Current Edition. (<https://dot.nebraska.gov/media/v45nhanu/access-control-policy.pdf>)
- 15.6 State of Nebraska Department of Transportation, Standard Specifications for Highway Construction (Spec Book), 2017 (<https://dot.nebraska.gov/media/g4qp4y0d/2017-specbook.pdf>)
- 15.7 Nebraska Revised Statutes, Chapter 39-1313 (<https://nebraskalegislature.gov/laws/statutes.php?statute=39-1313>)
- 15.8 Nebraska Revised Statutes, Chapter 39-1314 (<https://nebraskalegislature.gov/laws/statutes.php?statute=39-1314>)
- 15.9 Nebraska Revised Statutes, Chapter 39-1315 (<https://nebraskalegislature.gov/laws/statutes.php?statute=39-1315>)

The information contained in Chapter Sixteen: Pedestrian and Bicycle Facilities, dated May 2022, has been updated to reflect the January 2023 Errata. The errata addresses errors, changes in procedure, changes in NDOT department titles, changes in other Roadway Design Manual chapters and other reference material citations occurring since the latest publication of this chapter.

Chapter Sixteen presents guidance for the design of New and Reconstructed projects; design guidance for 3R projects is provided in Chapter Seventeen.

## Chapter Sixteen

# Pedestrian and Bicycle Facilities

The Americans with Disabilities Act Title II Regulations ([Americans with Disabilities Act Title II Regulations | ADA.gov](#)), Section 11-8.3000, requires a transition plan when structural modifications are required to provide pedestrian accessibility. The plan will list the physical barriers limiting accessibility, methods for the modification of the barriers, a time frame for achieving compliance with Title II, and the responsible party. **NDOT's** transition plan is found at [Transition Plan \(nebraska.gov\)](#).

In accordance with 28 C.F.R §35.150(d)(2) ([eCFR :: 28 CFR 35.150 -- Existing facilities.](#)), **NDOT** has a duty to include within this plan an evaluation of the location where pedestrian walks cross curbs on its highways. The federal rule states: If a public entity has responsibility or authority over streets, roads, or walkways, its transition plan shall include a schedule for providing curb ramps or other sloped areas where pedestrian walks cross curbs, giving priority to walkways serving entities covered by the Act, including State and local government offices and facilities, transportation, places of public accommodation, and employers, followed by walkways serving other areas.

### 1. RESOURCE PUBLICATIONS

#### **Pedestrians:**

The **Nebraska Department of Transportation (NDOT)** will follow the guidance found in the Accessibility Guidelines for Pedestrian Facilities in the Public Right-of-Way (2023) (*Accessibility Guidelines*) (Ref. 16.1), issued by the Architectural and Transportation Barriers Compliance Board (<https://www.federalregister.gov/documents/2023/08/08/2023-16149/accessibility-guidelines-for-pedestrian-facilities-in-the-public-right-of-way>). Pedestrian facilities may follow local ordinances, at the **Assistant Design Engineer's (ADE's)** discretion, if they meet or exceed **NDOT** requirements.

*Accessibility Guidelines* (Ref. 16.1) requirements which the **Roadway Design Engineer** determines are technically infeasible on a project shall be documented in the project's correspondence file with the **Roadway Design Engineer's** signature. The documentation must clearly demonstrate why it is technically infeasible to fully comply with the requirements and that the requirements have been met to the maximum extent practicable. For additional information see the **NDOT** Operating Instruction 60-10, "ADA Accessibility Requirements in Transportation Projects" (Appendix B, "Selected NDOT Operating Instructions").

### **Bicycles/Shared Use Paths:**

For further guidance beyond what is found in this manual the designer should refer to the **American Association of State Highway and Transportation Officials (AASHTO's) Guide for the Development of Bicycle Facilities** (Ref. 16.2).

### **Roundabouts:**

Requirements for pedestrian and bicycle access at a roundabout may be found in the *Accessibility Guidelines* (Ref. 16.1). For further guidance the designer should refer to NCHRP Report 672, "Roundabouts: An Informational Guide", Second Edition (Ref. 16.3) ([http://onlinepubs.trb.org/onlinepubs/nchrp/nchrp\\_rpt\\_672.pdf](http://onlinepubs.trb.org/onlinepubs/nchrp/nchrp_rpt_672.pdf)).

## **2. DEFINITIONS**

**ACCESSIBLE ROUTE** – A continuous and unobstructed pedestrian circulation path in the public right-of-way, the various components of which comply with the guidance found in the *Accessibility Guidelines* (Ref. 16.1).

**ADA** - The Americans with Disabilities Act of 1990 (<http://www.ada.gov/>), which provides comprehensive civil rights protection to individuals with disabilities in the areas of employment, transportation, public accommodations, state and local government services, and telecommunications.

**ALTERATION** - Defined by the *Accessibility Guidelines* (Ref. 16.1) as "A change to a facility in the public right-of-way that affects or could affect pedestrian access, circulation, or use. Alterations include, but are not limited to, resurfacing, rehabilitation, reconstruction, historic restoration, or changes or rearrangement of structural parts or elements of a facility."

**BICYCLE FACILITIES** – Defined by the Manual on Uniform Traffic Control Devices for Streets and Highways (*MUTCD*) as "A general term denoting improvements and provisions that accommodate or encourage bicycling, including parking and storage facilities, and shared roadways not specifically defined for bicycle use."

**BICYCLE LANE** - Defined by *MUTCD* as "A portion of a roadway that has been designated for preferential or exclusive use by bicyclists by pavement markings and, if used, signs."

**BIKEWAY** – Defined by *MUTCD* as "A generic term for any road, street, path or way that in some manner is specifically designated for bicycle travel, regardless of whether such facilities are designated for the exclusive use of bicycles or are to be shared with other transportation modes."

**BLENDED TRANSITION** – Defined by the *Accessibility Guidelines* (Ref. 16.1) as "A raised pedestrian street crossing, depressed corner, or similar connection between the pedestrian access route at the level of the sidewalk and the level of the pedestrian street crossing that has a grade of 5 percent or less."

**CROSS SLOPE** – Defined by the *Accessibility Guidelines* (Ref. 16.1) as "The grade that is perpendicular to the direction of pedestrian travel."

**CROSSWALK** - The Nebraska Revised Statutes, Chapter 60 Motor Vehicles defines a crosswalk as:

1. "That part of a roadway at an intersection included within the connections of the lateral lines of the sidewalks on opposite sides of such roadway measured from the curbs or, in the absence of curbs, from the edge of the roadway; or
2. Any portion of a roadway at an intersection or elsewhere distinctly designated by competent authority and marked for pedestrian crossing by lines, signs, or other devices."

**CURB RAMP** - A connection between the pedestrian access route at the level of the sidewalk and the level of the pedestrian street crossing that has a grade which is between 5 percent and 8.3 percent inclusive in the direction of pedestrian travel. Curb ramps can be perpendicular or parallel, or a combination of parallel and perpendicular ramps.

**PEDESTRIAN** – Defined by *MUTCD* as "A person on foot, in a wheelchair, on skates, or on a skateboard."

**PEDESTRIAN CROSSING** – A pedestrian crossing facilitates the movement of the non-motorized public (e.g. pedestrians, bicyclists) across highways, railroad tracks, and rivers or streams.

**PEDESTRIAN RAMP** – A part of an accessible route that has a running slope which is between 5 percent and 8.3 percent inclusive in the direction of pedestrian travel.

**PUBLIC RIGHT-OF-WAY** - Defined by the *Accessibility Guidelines* (Ref. 16.1) as "Public land or property, usually in interconnected corridors, that is acquired for or dedicated to transportation purposes.

**RUNNING SLOPE** - Defined by the *Accessibility Guidelines* (Ref. 16.1) as "The grade that is parallel to the direction of pedestrian travel."

**SHARED ROADWAY** - Defined by *MUTCD* as "A roadway that is officially designated and marked as a bicycle route, but which is open to motor vehicle travel and upon which no bicycle lane is designated."

**SHARED USE PATH** - Defined by *MUTCD* as "A bikeway outside the traveled way and physically separated from motorized vehicular traffic by an open space or barrier and either within the highway right-of-way or within an independent alignment. Shared-use paths are also used by pedestrians (including skaters, users of manual and motorized wheelchairs, and joggers) and other authorized motorized and non-motorized users."

**SIDEWALK** – Defined by *MUTCD* as "That portion of a street between the curb line, or the lateral line of a roadway, and the adjacent property line or on easements of private property that is paved and intended for use by pedestrians."

**TECHNICALLY INFEASIBLE** – Defined by the Department of Justice in the 2010 ADA Standards for Accessible Design as "...or because other existing physical or *site* constraints prohibit modification or *addition* of *elements, spaces*, or features that are in full and strict compliance with the minimum requirements." (emphasis original to DOJ) A finding of "technically infeasible" still requires that the element of the pedestrian path in question be built to the minimum applicable standards to the maximum extent possible.

### 3. BIKEWAYS AND SHARED USE PATHS

By statute, the **State of Nebraska** does not allow bicycles and pedestrians on the Interstate System or on freeways, see the Reissue Revised Statutes of Nebraska 60-6,142 (<https://nebraskalegislature.gov/laws/statutes.php?statute=60-6,142>) and 60-6,144 (<https://nebraskalegislature.gov/laws/statutes.php?statute=60-6,144>). The **State of Nebraska** does permit bicycles on other roadways and roadway shoulders.

In some cases, the scope of work of a highway improvement project may include construction of separate bicycle or pedestrian facilities. In many instances design features of separate bicycle facilities are controlled by the adjoining roadway and are an element of the design of the roadway itself. For further information on bicycle facilities, see the Guide for Development of Bicycle Facilities (Ref. 16.2).

SIDEWALK & SHARED USE PATH MINIMUM WIDTHS		
	ON ROW	ON BRIDGES
* <b>SIDEWALK</b>	Four feet, providing five foot by five foot passing spaces every 200 feet ( <b>NDOT</b> prefers a continuous five foot width).	Four feet, providing five foot by five foot passing spaces every 200 feet ( <b>NDOT</b> prefers a continuous five foot width).
** <b>SHARED USE PATH</b>	Ten feet Shared use path widths of 11 feet to 14 feet should be used where pedestrian use is $\geq 30\%$ of the total pathway volume and there are 300 total pathway users in the peak hour.	*** Ten feet

\* *Accessibility Guidelines* (Ref. 16.1)

\*\* Guide for the Development of Bicycle Facilities (Ref. 16.2)

\*\*\* Bridge Office Policies and Procedures (Ref. 16.6)

NOTE: Designers should check municipal ordinances in regard to sidewalk and bikeway width requirements. This check is for information; **NDOT** is not required to design to local ordinances; however, **NDOT** may design to the local ordinance as long as it meets minimum guidance and the additional work is accomplished at the municipality's cost.

#### Exhibit 16.1 Sidewalk and Shared Use Path Minimum Widths



## 4. SIDEWALKS

The need for sidewalk should be considered during the preliminary design of a project. The final determination regarding the need to include sidewalk in a project will be made at the plan-in-hand inspection, giving consideration to the input of the local governing authority and public. Items to consider in determining the need for sidewalk to be included in the project include:

- When sidewalk currently exists along a roadway, non-compliant sidewalk should be brought into compliance.
- Build new sidewalk only as required to match into the existing sidewalk in 15 feet or less of length unless this results in a grade greater than 15%. **ADE** approval is required to exceed a length of 15 feet and/or a grade greater than 15%.
- Areas which are accessible prior to the project should remain accessible at the conclusion of the project, unless technically infeasible.
- If an existing bridge structure with a sidewalk is to be rehabilitated or replaced, sidewalk will typically be retained or included on the new structure.
- When provided, new sidewalk should connect the origins and destinations of existing pedestrian trips within the project limits, e.g. residential development and schools.

### 4.A Sidewalk Design Considerations

Widths - Sidewalk widths may vary; the minimum width is four feet, however, **NDOT** prefers a continuous width of five feet. For sidewalks less than five feet in width a passing area shall be provided at intervals of 200 feet or less. The passing area shall be a minimum of five feet by five feet. See [EXHIBIT 16.1](#) for additional information.

Cross Slope - The maximum allowable cross slope is 2%, except as noted elsewhere herein. **NDOT** prefers a cross slope of 1.5% to allow for construction tolerance.

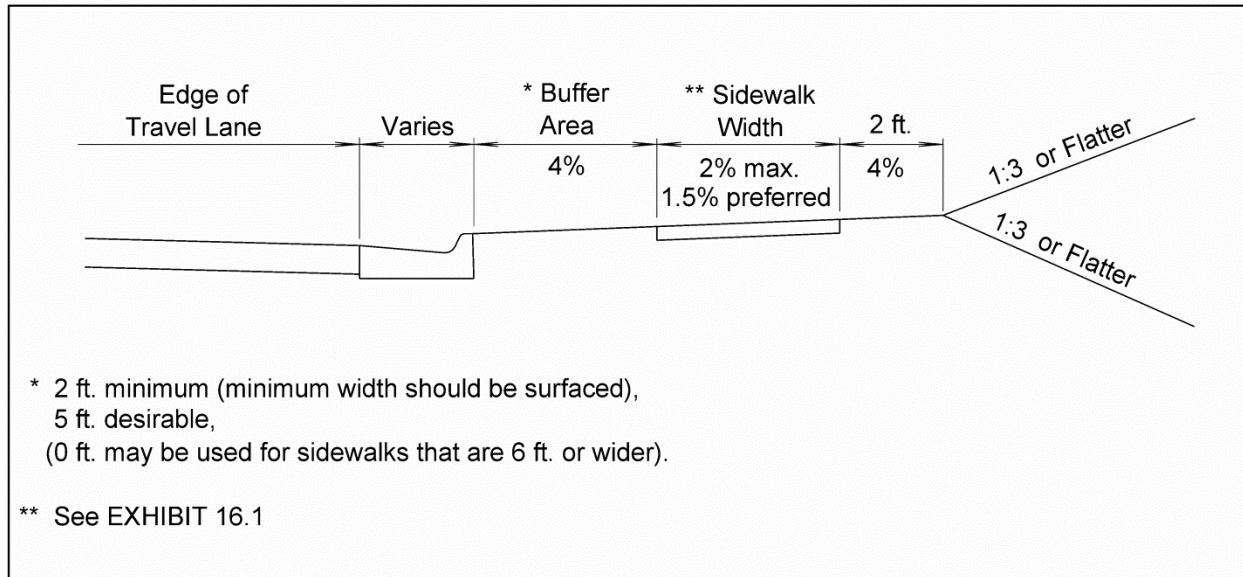
Running Slope (Grade) – Where the sidewalk is contained within the right-of-way, its grade shall not exceed the general grade established for the adjacent street or highway. When the sidewalk profile is independent of the roadway alignment, the maximum allowable sidewalk grade is 5%; if the grade of the sidewalk exceeds 5% a pedestrian ramp will be required.

Buffer Areas - Generally, based on the available right-of-way, a five foot wide buffer area between the back of curb and the edge of sidewalk is the preferred section ([EXHIBIT 16.2](#) illustrates the typical sidewalk section). Where right-of-way is limited a minimum buffer width of two feet should be provided to allow adequate space for hydrants, parking meters, and other roadside appurtenances. If no buffer is provided, a sidewalk width of six feet is provided to accommodate both these appurtenances and a minimum continuous four foot width for an access path.

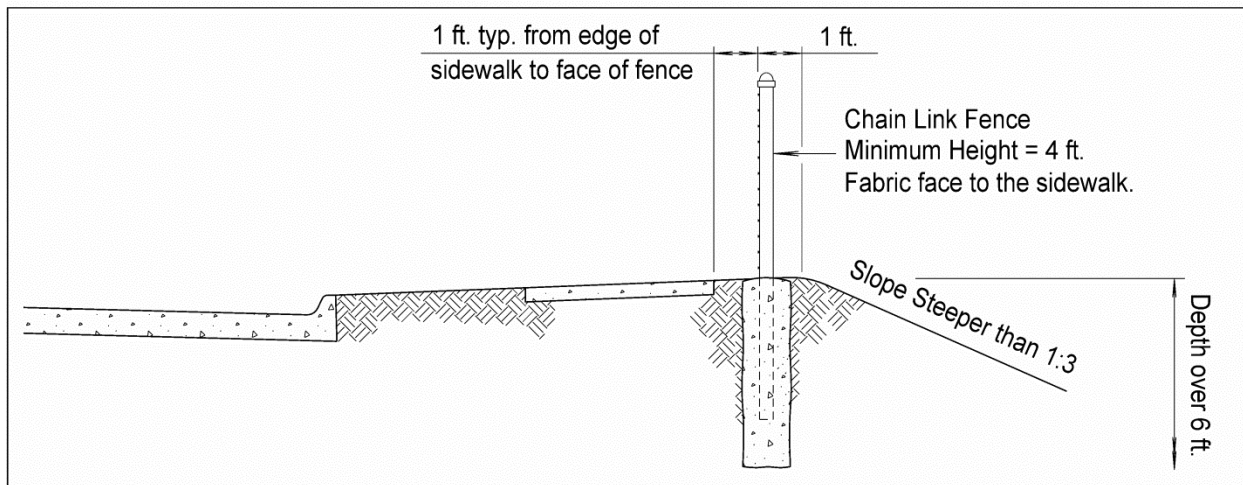
Protruding Objects – No object will be allowed to protrude more than four inches into the pedestrian circulation path between a height of two feet three inches and six feet eight inches above the sidewalk surface.

Curb Ramps - See Section 7 of this chapter.

**Fencing** – When a sidewalk is adjacent to a steep slope (steeper than 1:3) which is sloping away from the sidewalk, is over six feet in depth, and where no handrail or barrier is present a chain link fence should be installed, typically one foot from the sidewalk (See EXHIBIT 16.3). The fence should have a minimum height of four feet with the chain link fabric facing the sidewalk. If the sidewalk and the steep slope are on the approach to a viaduct or overpass, the concrete bridge railing should be extended onto the approach slab and, where possible, the sidewalk flared away from the traffic.



**Exhibit 16.2 Typical Sidewalk Section**



**Exhibit 16.3 Fencing on Steep Slopes Adjacent to a Sidewalk**

## 5. PEDESTRIAN UNDERPASSES

The minimum width of an underpass should be the clear width of the approaching sidewalk/shared use path; the desirable width is the sidewalk/shared use path width plus two feet clearance on each side. The minimum vertical clearance should be ten feet. For underpasses over 60 feet in length both dimensions may be increased. Sight lines should be unobstructed, providing a clear view of the open ends of the tunnel. The designer will address the concerns of the underpass users (including location and ventilation) and the drainage of the facility when designing the underpass. Lighting of the underpass will be coordinated with the **Roadway Design Lighting Unit**.

## 6. PEDESTRIAN CROSSINGS

Warrant analysis for mid-block pedestrian street crossings, pedestrian crossings at railroad tracks, and for pedestrian structures (overpasses and underpasses) is the responsibility of the **Traffic Engineering Division (Traffic Engineering)** and will be developed during the plan-in-hand or public meeting processes. The roadway designer will coordinate the design of the pedestrian crossing with the design of the highway, sidewalk/bikeway, railroad crossing, and/or bridge.

The design guidance for a pedestrian crossing includes:

- A pedestrian street crossing (hereafter referred to as a crosswalk) will connect departure and arrival sidewalks.
- Crosswalks shall continue through medians. The designer will verify that raised medians in the urban section of a project adhere to the *Accessibility Guidelines* (Ref. 16.1), providing pedestrian access across the street from curb ramp to curb ramp.
- On wide, divided roadways, **Traffic Engineering** may require a pedestrian refuge area in the median. A pedestrian refuge is an area a minimum of six feet wide in the direction of pedestrian travel that allows a pedestrian to stop and wait for traffic mid-crossing.
- Marked crosswalks shall be a minimum six feet wide.
- The maximum running slope in the direction of pedestrian travel shall be 5%.
- The maximum cross-slope at a yield or stop sign controlled crosswalk shall be 2%.
- The maximum cross-slope at a crosswalk that is not yield or stop sign controlled is 5%.
- The cross-slope of a mid-block crosswalk is permitted to match the street grade.
- Where a pedestrian structure is required, the **Bridge Division (Bridge)** is responsible for the design of the structure.
- Accessible pedestrian signals are optional devices that provide non-visual guidance for those with visual disabilities. They are not routinely installed on signal projects but can be installed upon request for, and the completion of, an engineering study that determines if they are needed for the project. The designer will coordinate the provision of accessible pedestrian signals at crosswalks with **Traffic Engineering**; for further information see Chapter Fourteen: Traffic, Section 4.A.

## 7. CURB RAMPS

Curb ramps compliant with the *Accessibility Guidelines* (Ref. 16.1) **are required**:

- At crosswalks (marked or unmarked)
- At an intersection having curb or other barriers to entry from a walkway
- Where accessible on-street parking is provided

Curb ramps **shall be** constructed or reconstructed on any New, Reconstructed, or 3R project where surfacing of any thickness, with or without milling, is placed on a crosswalk, whether the crosswalk is on the project mainline, on a side street, or at a signalized driveway or alley. Curb ramps are not required if the new surfacing does not extend to the crosswalk. Curb ramps may be built on any project, including Preventive Maintenance, with the concurrence of the **District Engineer (DE)** and the **Roadway Design Engineer**.

Curb ramps will be built using the curb ramp plan (See the Standard/Special Plans Book (Standard Plans), Ref. 16.4) <http://www.roads.nebraska.gov/business-center/design-consultant/stand-spec-manual/>).

Design guidance for curb ramps includes, but is not limited to:

- A curb ramp is a transition from the pedestrian access route to the pedestrian street crossing with a grade which is between 5% and 8.3% inclusive in the direction of pedestrian travel (the roadway designer is advised to design curb ramps to an 8% maximum slope whenever possible to allow for construction tolerance).
- A blended transition connects a pedestrian access route and a pedestrian street crossing with a grade of less than 5% in the direction of pedestrian travel. A blended transition will hereafter be referred to as a curb ramp and will be built using the curb ramp plan (See the *Standard Plans*, Ref. 16.4).
- The desirable orientation of a curb ramp is perpendicular to the direction of crossing vehicular traffic. A diagonal orientation should only be used when physical constraints preclude the use of a perpendicular ramp.
- When tying a curb ramp to existing sidewalk, build new sidewalk only as required to match into the existing sidewalk in 15 feet or less of length unless this results in a grade greater than 15%. **ADE** approval is required to exceed a length of 15 feet and/or a grade greater than 15%.
- On reconstruction projects, the *Proposed Guidelines (2013)* allows a transitional segment of sidewalk to match the cross slope of the existing sidewalk; this transition does not require technically infeasible documentation to the project file.
- Curb ramps should be the width of the sidewalk and shall be a minimum of four feet wide (exclusive of flared sides). Curb ramps on shared use paths will be the full width of the path.
- The maximum allowable ramp cross slope (perpendicular to the direction of pedestrian travel) is 2%; the preferred cross slope is 1.5%.
- Curb ramp length shall not exceed 15 feet.
- Where a side of a perpendicular curb ramp abuts a public sidewalk, the sides of the ramp shall be flared with a maximum 10% slope.
- A four foot by four foot minimum turning space will be provided at either the top of a perpendicular curb ramp or at the bottom of a parallel curb ramp. The turning space will

have a 2% maximum slope in any direction (**NDOT** prefers a slope of 1.5%). A five foot diameter for wheel chair foot rest swing is required if the turning space is adjacent to a vertical obstruction.

- The surface of a curb ramp shall be stable, firm, and slip-resistant.
- Gratings and similar access covers shall not be located on curb ramps or turning spaces.
- A detectable warning area for the visually impaired consisting of truncated domes shall be provided at each pedestrian curb ramp located at intersections, crosswalks, islands that are six feet in width or greater, and at signalized drives and alleys where a vehicle is not intended to stop.
- The detectable warning panels shall contrast visually with the adjacent gutter, street, or sidewalk (either darker or lighter).
- Detectable warning panels will typically be cast-in-place when built with a new curb ramp.
- When a surface applied detectable warning panel is used on an existing curb ramp, the bid pay item is “Detectable Warning Panel”.
- Transitions shall be free of abrupt changes:
  1. If the project changes the grade at the gutterline of an existing roadway through a crosswalk with existing curb ramps by one-quarter inch or less, no adjustment is required.
  2. If the project changes the grade at the gutterline of an existing roadway through a crosswalk with existing curb ramps by one-quarter inch to one-half inch, the grade change should be beveled at a maximum 1:2 ratio.
  3. If the project changes the grade of the existing roadway at the gutterline through a crosswalk with existing curb ramps by more than one-half inch, either match the grade at the gutterline through the crosswalk or reconstruct the curb ramp to current standards.
- Counter slopes of adjoining gutters and road surfaces connecting to the full width of a curb ramp shall be a maximum of 5%, measured along the direction of pedestrian travel (See [EXHIBIT 16.4](#)).
- Grade breaks must be perpendicular to the direction of pedestrian travel.
- Surface slopes that meet at grade breaks shall be flush.
- Pavement drainage is a particular concern at curb ramps. Consideration will be given to the locations of inlets and sidewalks or crosswalks to verify that there is sufficient room for the five foot blockout width required for a curb inlet and that neither grates nor ponded water are impediments to pedestrian travel (See the [Drainage Design and Erosion Control Manual \(Drainage Manual\)](#), Ref. 16.5, Chapter One: [Drainage](#), Section 10.B.1) (<http://www.roads.nebraska.gov/business-center/design-consultant/rd-manuals/>)
- Curb ramps may be constructed to meet local ordinances if those requirements meet or exceed **NDOT** requirements. Additional project costs associated with local ordinances will normally be the responsibility of the Municipality.
- Exemptions to the above requirements for curb ramps may be granted if:
  1. The curb ramp has been constructed to the standards to the maximum extent practicable,
  2. It is “technically infeasible” to construct a curb ramp which meets all of the standards, **and**
  3. There is an accessible alternate route approved by the municipality (a Municipal agreement will be required).

- An exemption to the construction of a curb ramp requires the **Roadway Design Engineer's** written approval in the project file. This exemption letter will document that the curb ramp was constructed to the maximum extent practicable, which aspects of the curb ramp were not built to the standards, and why it is technically infeasible to meet all of the requirements of the *Accessibility Guidelines* (Ref. 16.1).
- When there are no pedestrian facilities crossing the project, the designer **must** document this fact in the plan-in-hand report or in a decision document saved in the project file as the reason why curb ramps were not provided with the project.

Design details for curb ramps may vary according to many factors, including:

- Intersection radius
- Angle of street intersections
- Location of obstacles (e.g. fire hydrants, signs, and signal control devices)
- Possible sight obstructions
- Suitable location for stop bar

For additional information see the Nebraska Department of Transportation Operating Instruction 60-10, "ADA Accessibility Requirements in Transportation Projects" (Appendix B, "Selected NDOT Operating Instructions").

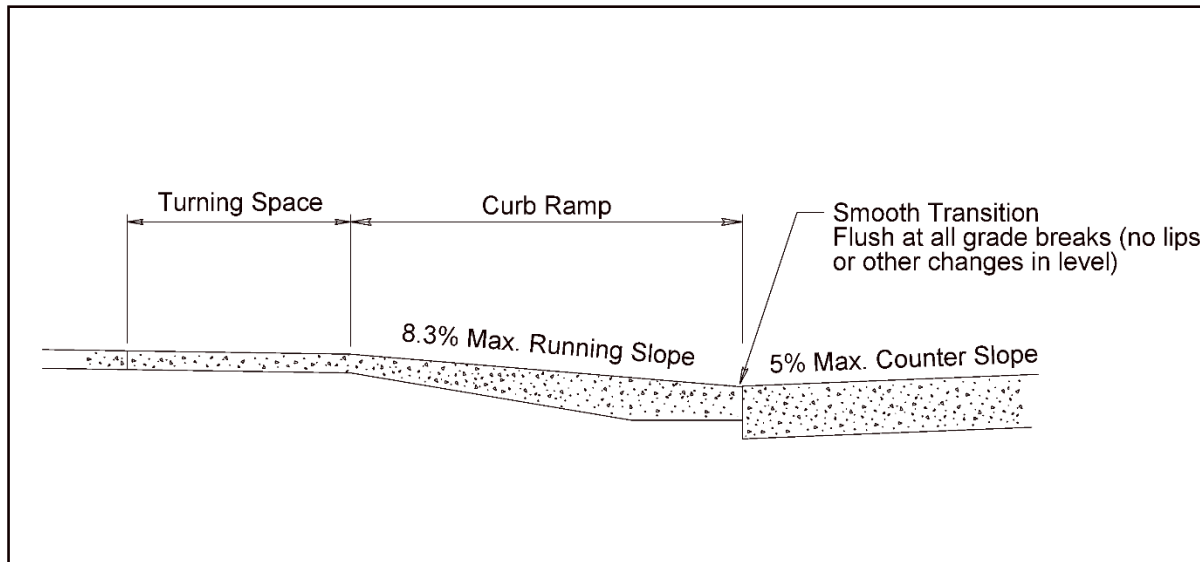


Exhibit 16.4 Curb Ramp Counter Slopes

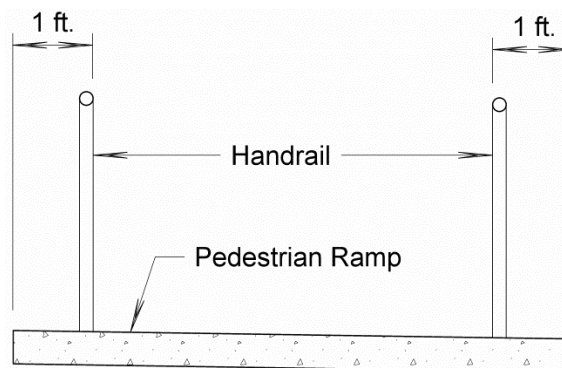
## 8. ACCESSIBLE ON-STREET PARKING

See Chapter Ten: Miscellaneous Design Issues, Section 13.A.

## 9. PEDESTRIAN RAMPS

A part of an accessible pedestrian route that has a slope which is between 5% minimum and 8.3% maximum in the direction of travel will be considered a pedestrian ramp and shall comply with the *Accessibility Guidelines* (Ref. 16.1) requirements, including:

- The maximum allowable slope of a pedestrian ramp in new construction shall be 8.3% in the direction of travel (with a desirable maximum slope of 8%).
- The maximum allowable cross slope shall be no greater than 2% (**NDOT** preferred cross slope is 1.5%).
- The maximum allowable rise for a length of run shall be 30 inches.
- Pedestrian ramps shall have a minimum clear width of four feet and shall have landings at the top and bottom of each ramp.
- The maximum allowable cross slope of a landing is 2% in any direction (**NDOT** prefers a cross slope of 1.5%).
- Landings shall be at least as wide as the pedestrian ramp and the length of the landing shall be at least five feet. If the pedestrian ramp changes direction at the landing, the landing shall have a minimum size of five feet by five feet.
- Pedestrian ramps which have a rise of more than six inches or are six feet or greater in length shall have handrails on both sides of the ramp (curb ramps are not required to have handrails).
- The surface of the pedestrian ramp run and landing shall extend a minimum of 12 inches beyond the inside face of the handrail (See EXHIBIT 16.5).
- Pedestrian ramps and their approaches will be designed so that water will not pond on walking surfaces.
- The surface of the pedestrian access route shall be firm, stable, and slip resistant.



**Exhibit 16.5 Typical Section of a Pedestrian Ramp**  
(Adapted from the *Proposed Guidelines (2013)*, Ref. 16.1)

## 10. STEPS AND STAIRS

Exterior stairs which connect levels that are not connected by an elevator, ramp, or other accessible means of vertical access must comply with the following *Accessibility Guidelines* (Ref. 16.1) guidelines:

- Steps on a flight of stairs shall have uniform riser heights of between four inches and seven inches and uniform tread widths of not less than 11 inches as measured from riser to riser.
- Stairway treads shall include a minimum two-inch wide strip which contrasts visually with the tread and riser. The strip shall be located at the front of and shall run the full width of the tread.
- The undersides of nosings shall not be abrupt. The radius of curvature at the leading edge of the tread shall be no greater than one-half inch.
- Risers shall be sloped or the underside of the nosing shall have a maximum angle of 30° from the vertical. Nosings shall project not more than one and one-half inches.
- Stairways shall have handrails on both sides of the stairs (See Section 11 of this chapter).
- Exterior stairs and their approaches shall be designed so that water will not pond on the walking surface.

The **Special Projects Unit** in **Bridge** will provide site-specific plans upon request from the roadway designer.

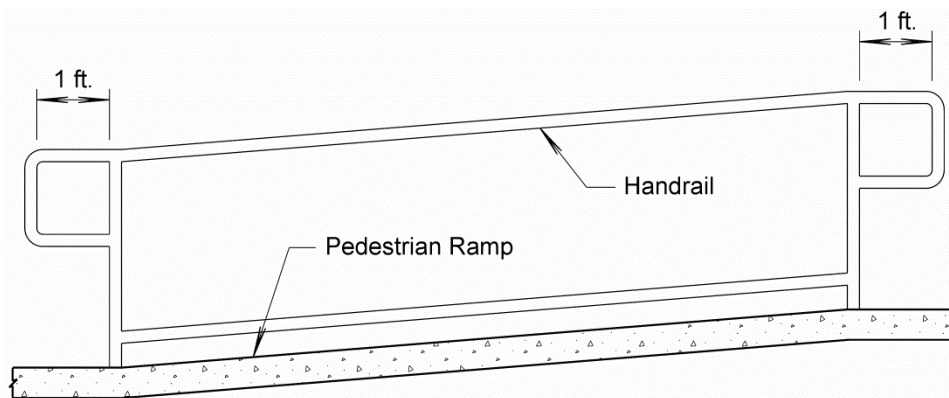
## 11. HANDRAILS FOR PEDESTRIAN RAMPS AND STAIRS

Handrails shall comply with the *Accessibility Guidelines* (Ref. 16.1) and will have the following features:

- Where required, handrails shall be provided along both sides of stairs and pedestrian ramp segments. The inside rail shall be continuous.
- If handrails are not continuous, they shall extend at least one foot beyond the top and bottom of the pedestrian ramp segment and the extension shall be parallel to the landing (See EXHIBIT 16.6).
- The minimum clear space between handrails and a vertical surface shall be one and one-half inches.
- Gripping surfaces shall be continuous.
- The top of handrails shall be between 34 and 38 inches vertically above the walking surface, stair nosing, and pedestrian ramp surface. The height of the handrail shall be consistent.
- Ends of handrails shall be rounded or smoothly turned to the wall, floor, or post.
- Handrails shall not rotate within their fittings.

The **Special Projects Unit** in **Bridge** will provide site-specific plans upon request from the roadway designer.





**Exhibit 16.6 Typical Handrail Extension at a Pedestrian Ramp**  
(Adapted from the *Proposed Guidelines (2013)*, Ref. 16.1)

## 12. PEDESTRIAN ACCESS DURING CONSTRUCTION

When construction obstructs pedestrian access, the roadway designer will consider the need for temporary access measures for pedestrians with disabilities to businesses or other publicly-used facilities during the construction of the project. The designer will also address the needs of disabled individuals crossing the project during construction and the need for implementing temporary measures to meet these needs when identified. Special consideration will be given to schools (when in session), publicly-accessed government offices and medical facilities. The designer will inform **PS&E** of the need to include the Special Provision titled “Pedestrian Access During Construction” on projects where there are pedestrian facilities within the limits of the project.

### 12.A Pedestrian Access Review

The roadway design process includes an investigation to determine the need for accessibility of the sidewalk, shared use path, and street crossings for disabled individuals during the construction of the project as follows:

**Roadway Design (Activity 5300, Clarity Task Code 5350)**: Prior to the plan-in-hand field inspection the roadway designer will take into account the possible need for disabled individuals to use the sidewalks, shared use paths, and street crossings in and through the project area. The designer will estimate the time of closure for the pedestrian access construction phase of the project, including utilities and other construction items, to assist in:

- Determining the type of temporary access required
- Designing the phasing of the pedestrian access
- The preparation of NEPA documents (if required)

This information will be made available to the public at a public meeting.

The roadway designer will request that the **District** investigate the need for access in and across the project area by pedestrians with disabilities and that the **District** contact public officials, business owners, and others, reporting the findings to **Roadway Design** at the plan in hand inspection. The evaluation of the use of the sidewalks, shared use paths, and street crossings in and through the construction zone by individuals with disabilities should include, but not be limited to:

- Contacting organizations in the community that provide support for persons with disabilities for their input
- An identification of people with disabilities living in, working in, or using the area of the project
- A determination of how, when, and in what way the area of the project is likely to be used by specifically identified persons with disabilities
- Obtaining the recommendations of the local officials regarding which temporary access measures should be considered during the construction of the project

**Plan-In-Hand (Activity 5300, Clarity Task Code 5380):** The roadway designer and **District** personnel should review commercial or publicly-used buildings along the project where the public access route provides the primary or only public pedestrian access to the building. The **District** should further identify how the project will impact pedestrian access to schools, governmental offices, medical facilities, and other buildings that are likely to generate regular pedestrian traffic on the public sidewalks, shared use paths, and street crossings. **Municipality/Village** representatives should be invited to attend the plan-in-hand to discuss handicapped accessible routes and known accessibility needs, both when the project is complete and during construction.

**Public Meetings:** The engineering statement or video for public meetings should address temporary pedestrian access during the construction of the project, e.g. “We are reviewing and will address pedestrian access”, and request information to identify needs for access in or across the project area during construction.

The roadway designer will compile the available information concerning disabled pedestrian access and discuss the need for temporary facilities which are to be constructed as a part of the project with his/her **Roadway Design Unit Head (Unit Head)** and with the **District**. If there is no identifiable need for special accommodation for access to use the project area during the construction period, special accommodations will not be included with the plans, however a special provision will be added to the project stating that the **District** will be responsible for providing pedestrian access identified during construction.

**Design Detail Review (Activity 5500, Clarity Task Code 5576):** Before notification that the Roadway Design Detail Plans are available (Clarity Task Code 5550), **District** personnel should meet with local officials, property owners, and local resource agencies for disabled persons to:

- Verify that the information concerning the usage patterns and subsequent needs of disabled pedestrians is current
- Inform the local officials and resource agencies of the proposed temporary pedestrian access facilities and of the tentative project schedule

**12.B      Example Special Provisions**

- The contractor will construct sidewalks in such a way that will minimize the time that pedestrian access to properties along the project is closed.
- The contractor will maintain pedestrian traffic at all times that the business is open or provide an accessible route to be used during the closing of sidewalk at Station \_\_\_\_\_.
- The contractor may close the sidewalk from Friday to Monday (after normal business hours or when the business is closed).
- The contractor must construct a temporary ADA pedestrian accessible path or access at Station \_\_\_\_\_.
- The contractor will develop and implement a plan for the phasing of work that involves the obstruction, removal, or construction of sidewalks to minimize the disruption of pedestrian access to adjoining businesses. A plan will be implemented to provide reasonable temporary access during sidewalk construction to a business that uses the public sidewalk for its only or ADA accessible pedestrian access.

**13.            ADA UPGRADES - COST SHARING**

See the Nebraska Dept. of Transportation Operating Instruction 60-11, "Municipal Cost Sharing" (Appendix B, "Selected NDOT Operating Instructions").

## 14. REFERENCES

- 16.1 Architectural and Transportation Barriers Compliance Board, Accessibility Guidelines for Pedestrian Facilities in the Public Right-of-Way (*Accessibility Guidelines*), Washington, D.C., August 8, 2023. (<https://www.federalregister.gov/documents/2023/08/08/2023-16149/accessibility-guidelines-for-pedestrian-facilities-in-the-public-right-of-way>)
- 16.2 American Association of State Highway and Transportation Officials, Guide for the Development of Bicycle Facilities, Fourth Edition, Washington, D.C., 2012.
- 16.3 Transportation Research Board, "Roundabouts: An Informational Guide – Second Edition", NCHRP Report 672, Washington, DC, 2010. ([http://onlinepubs.trb.org/onlinepubs/nchrp/nchrp\\_rpt\\_672.pdf](http://onlinepubs.trb.org/onlinepubs/nchrp/nchrp_rpt_672.pdf))
- 16.4 Nebraska Department of Transportation, Standard/Special Plans Book (*Standard Plans*), Current Edition. (<http://www.roads.nebraska.gov/business-center/design-consultant/stand-spec-manual/>)
- 16.5 Nebraska Department of Transportation, Drainage Design and Erosion Control Manual (*Drainage Manual*), Current Edition. (<http://www.roads.nebraska.gov/business-center/design-consultant/rd-manuals/>)
- 16.6 Nebraska Department of Transportation, Bridge Office Policies and Procedures (*BOPP*), 2013. (<http://www.roads.nebraska.gov/media/2912/bopp-manual.pdf>)
- 16.7 Nebraska Department of Transportation, Design Process Outline (*DPO*), Current Edition. (<https://dot.nebraska.gov/business-center/design-consultant/>)

The information contained in Chapter Seventeen: Resurfacing, Restoration and Rehabilitation (3R) Projects, dated May 2022, has been updated to reflect the October 2023 Errata. The errata incorporates DES 22-03: “Practical Design: Bridge or Culvert Replacement Projects” (approved by the Nebraska Division of the FHWA on January 18, 2023), incorporates DES 23-02: “3R Standards for Expressways with Access only at Interchanges” (approved by the Nebraska Division of the FHWA on August 11, 2023), addresses errors, changes in procedure, changes in NDOT department titles, changes in other Roadway Design Manual chapters and other reference material citations occurring since the latest publication of this chapter.

Chapter Seventeen provides requirements and guidance unique or specific to the design of 3R projects and such requirements and guidance take precedence over those in other chapters. Information in other chapters may still apply to a 3R project, if not included in Chapter 17.

The arrangement of Chapter Seventeen generally follows the Chapter order of the Roadway Design Manual (RDM) (e.g. Earthwork is Chapter Seven of the *RDM* and Section 7 of Chapter Seventeen).

## Chapter Seventeen

# Resurfacing, Restoration and Rehabilitation (3R) Projects

Resurfacing, Restoration and Rehabilitation (3R) projects are generally undertaken to preserve and extend the life of highway assets. Most 3R projects are initiated because of a pavement condition that indicates a need for pavement resurfacing, or a bridge condition that indicates a need for bridge rehabilitation or repair. Generally, it is not the purpose of 3R projects to increase highway capacity. 3R projects improve the reliability of the transportation system, maintain the mobility of the highway user, and may mitigate highway operational and safety issues. A 3R project usually involves pavement resurfacing or rehabilitation, sometimes accompanied by cross-section or roadside improvements. These projects may include, but are not limited to:

- Improvements to grades, vertical curves and horizontal curves, including superelevation
- Improving intersections and railroad crossings
- Building or upgrading roadway appurtenances, such as guardrail
- Improving and/or widening through lanes and shoulders
- Flattening of sideslopes
- Removing, relocating, replacing or shielding roadside obstacles (e.g. culvert headwalls)
- Improving stopping sight distances
- Incidental improvements relating to safety or traffic operations (e.g. rumble strips, striping, beveled edge)
- Increasing pavement friction
- Short segments of roadway designed to New and Reconstructed standards (see Section Chapter One: Roadway Design Standards, Section 6.B, of this manual)
- Segments designated as maintenance activities
- Bridge work of all types
- Adding auxiliary lanes, including turning and passing lanes (e.g. Super 2 corridors, see Section 1.G of this chapter)

- 3R improvements adjacent to 2 new lanes (2 plus 2 strategy, see Section 1.F of this chapter)
- Restoring the surfacing base to the original condition
- Removing a portion of the existing base to accommodate the required pavement thickness
- Recycling strategies which incorporate the existing road surfacing or structure into the base
- Signing, reflexive guide posts, pavement marking and traffic signals
- Building or upgrading curb ramps

As a starting point, 3R projects shall solve the documented problem by updating pavement and/or bridge assets. As part of the design process, the **Roadway Design Division (Roadway)** will consider operational and crash mitigation measures, as recommended by the **Traffic Engineering Division (Traffic Engineering)**. Other improvements or changes to the existing highway may also be considered for inclusion in the work scope if the estimated benefits (e.g. reduced number or severity of crashes, reduced maintenance costs) over the anticipated life cycle of the project are more than the estimated extra costs of designing and constructing them. Conversely, if costs exceed benefits, a change being considered may not be included in the scope of work. The **Nebraska Department of Transportation (NDOT)** is required to evaluate compliance with the Nebraska Minimum Design Standards (MDS) (Ref. 17.1), found in Chapter 2 of the Nebraska Administrative Code, Title 428 (<https://dot.nebraska.gov/media/1z1n5kmb/nac-428-rules-regs-nbcs.pdf>), issued by the **Board of Public Roads Classifications and Standards (Board of Public Roads)**.

### **The NDOT Policy on The Predicted Safety Performance of 3R Projects**

It is desirable that a 3R project will improve the overall safety performance of the highway, as estimated by a documented analysis during the design phase. It is required that a 3R project not reduce the overall safety performance of the highway.

### **Analyses of Benefits Versus Costs**

A performance-based design process using benefit/cost analyses provides the basis for design of 3R projects, focusing on the decision whether to include improvements in the scope of a 3R project. They determine the cost effectiveness of crash mitigation measures, lane or shoulder widening, flattening of slopes and other scope-of-work decisions. The costs and benefits of alternatives are compared to achieve a practicable approach, without sacrificing the overall safety of the segment. **Benefits** are generally crash reduction savings or operational improvements. **Costs** to be considered include (but are not limited to) construction, permitting, National Environmental Policy Act (NEPA) compliance, Preliminary Engineering, Construction Engineering, Right-of-Way, Utilities, Contingencies, Mobilization, Temporary Roads and/or Detours. Roadway designers may also consider the project schedule and potential delay to the improvement. Analyses and decisions as a result of a benefit/cost analysis shall be documented in the project file, with approval by the **Roadway Design Assistant Design Engineer (ADE)**.

For additional guidance, see NCHRP Report 876, Guidelines for Integrating Safety and Cost-Effectiveness into Resurfacing, Restoration, and Rehabilitation (3R) Projects (*NCHRP Report 876*) (Ref. 17.2) (<https://nap.nationalacademies.org/catalog/25206/guidelines-for-integrating-safety-and-cost-effectiveness-into-resurfacing-restoration-and-rehabilitation-3r-projects>).

## 1. 3R DESIGN STANDARDS AND GUIDELINES

Minimum design standards for 3R work on State highways have been issued by the **Board of Public Roads** in the *MDS* (Ref. 17.1). If these standards for 3R work cannot be satisfied, the procedure for the relaxation of the 3R minimum design standards must be followed (See Chapter One: Roadway Design Standards, Section 10.B, of this manual).

### 1.A 3R Versus Other Work Types

In comparison to New or Reconstructed projects, 3R projects generally have a shorter project delivery time, have fewer impacts on the environment, fewer and less extensive right-of-way acquisitions, and are less costly. Preventive Maintenance projects generally have even fewer impacts and lower costs. A reconstruction strategy is generally applied when an entire project segment needs to be completely re-built, including a new or modified base. For additional information, see Chapter One: Roadway Design Standards: Section 6, of this manual.

For resurfacing projects, the appropriate minimum design standards are applied to the project segment based on the expected service life. Each design standard and the associated project's expected service life are as follows.

- **PREVENTIVE MAINTENANCE:** A highway surface maintenance strategy has an expected service life of up to 12 years.
- **RESURFACING, RESTORATION AND REHABILITATION (3R):** A 3R resurfacing strategy typically has an expected service life up to 20 years.
- **NEW AND RECONSTRUCTED:** A pavement strategy typically involves construction or reconstruction of an entire pavement, base and subgrade system; these projects have an expected service life exceeding 20 years.

For some 3R projects, it may be appropriate to apply New and Reconstructed standards to a segment (or segments) within the length of the project (See Chapter One: Roadway Design Standards, Section 6.A, of this manual). For any such segment, if these standards cannot be satisfied, the procedure for the relaxation of the New and Reconstructed minimum design standards will be followed (See Chapter One: Roadway Design Standards, Section 10.B, of this manual). It may not always be practicable to apply New and Reconstructed standards.

For the design process, system preservation projects are initially separated into two categories, typically based on the equivalent thickness of the pavement strategy as recommended by the **Materials and Research Division (M&R)**:

- i. Two inches or less of surfacing or its equivalent<sup>1</sup> thickness.
  - a. Processed by **Roadway** as a Preventive Maintenance project.
- ii. More than two inches of surfacing or its equivalent<sup>1</sup> thickness.
  - a. Processed by **Roadway**.
  - b. Initially assumed to be a 3R scope of work, with the application of 3R standards.

---

<sup>1</sup> M&R has determined that two inches of in place recycle is structurally equivalent to one-quarter inch of Hot Mix Asphalt, e.g. a pavement determination of two inches of in place recycle followed by a one and one-half inch overlay is equivalent to a two-inch resurfacing.

During the design process, these initial assumptions need to be verified. For some projects, the scope may be adjusted and different standards than initially assumed may be applied. For resurfacing projects, consistency with the expected service life is an important factor. For example, a curbed segment has an initial assumption of Category ii, i.e. 3R standards (expected service life up to 20 years) but the design process leads to a full-depth pavement reconstruction and application of New and Reconstructed standards. That is outside the scope of the primary need, which is system preservation. The strategy therefore may be adjusted to fit a Preventive Maintenance scope (expected service life up to 12 years) to address the primary need.

Another possibility is adjusting the scope of a Category i project to more than two inches of equivalent thickness and the project remains as a Preventive Maintenance project (expected service life up to 12 years). In rare cases, for a variety of factors, it may be anticipated that the typical maintenance strategy will fail well before its expected service life. These factors include, but are not limited to the existing pavement condition, overall pavement thickness, heavy truck loading and environmental conditions. At the **Roadway Design Unit Head's (Unit Head)** request, the **Pavement Design Engineer in M&R** may evaluate the expected service life of a proposed maintenance strategy on a specific project. If the **Pavement Design Engineer** determines the strategy will not meet its anticipated service life, the equivalent surfacing thickness may exceed two inches and still be constructed to Preventive Maintenance standards as long as the expected service life does not exceed 12 years.

A pavement strategy that requires replacement of the entire pavement structure and construction of a new base or modification<sup>2</sup> of the existing base will generally be designed to New and Reconstructed standards. However, practical design considerations may allow deferment of widening the highway cross-section to a future New and Reconstructed project, and the application of 3R standards to the current project. Examples include reconstructing the pavement structure without modification of the existing base, and short segments built to New and Reconstructed standards.

If it is determined that *reducing* an existing geometric design feature is practicable, according to a documented benefit-cost analysis, it can be reduced. However, it cannot be reduced below the current 3R guidance in the *MDS* (Ref. 17.1) without first receiving a Design Relaxation of the *MDS* and/or Design Exception (See Chapter One: Roadway Design Standards, Section 10.B, of this manual) and, for shoulder width for a segment on the Priority Commercial System, below the Priority Commercial System policy (See Chapter Six: The Typical Roadway Cross-Section, Section 2.A.1, of this manual) without approval of the **ADE**.

---

<sup>2</sup> Modification of the base is defined as improving (addition of a foundation course) or strengthening the existing base through chemical (fly ash, lime, etc.) or mechanical (geofabric, geogrid, etc.) means. It does not include Subgrade Preparation of an existing base which is considered Restoration of the base to its original condition.



**1.B      3R Design Controls**

**1.B.1      Design Year Forecast Traffic**

The design year for all 3R projects is 20 years (the year of initial construction plus the expected life of the pavement).

**1.B.2      Design Speed**

The minimum design speed is the speed limit determined by **Traffic Engineering** to be posted at the completion of the construction of the 3R project. For segments within the termini of a 3R project designed to New and Reconstructed standards, the design speed of the segment will be the appropriate New and Reconstructed project design speed (See Chapter One: Roadway Design Standards, Section 7.B, of this manual).

**1.C      Bridge Rehabilitation (3R) Work**

See Chapter One: Roadway Design Standards, Section 6.B.1, and Section 10.B of this chapter.

## 1.D Interstate NHS 3R Projects

The Nebraska criteria follows the **American Association of State Highway and Transportation Officials (AASHTO)** publication, A Policy on Design Standards - Interstate System (*I-State Green Book*) (Ref. 17.4). The minimum design standards used for 3R Interstate projects should be the **AASHTO** Interstate standards that were in effect at the time of the most recent New and Reconstructed project on the section of the Interstate or its inclusion into the Interstate system, and the 3R criteria described in the *MDS* (Ref. 17.1). Interstate design criteria that does not meet **AASHTO** guidance requires a design exception and a relaxation of the *MDS* (Ref. 17.1) (see Chapter One: Design Standards, Section 10, of this manual).

Interstate pavement replacement projects should be designed to *MDS* (Ref. 17.1). New and Reconstruction standards and are not addressed in this chapter.

### 1.D.1 **Wyoming to Big Springs (0+00 to 102+00)**

THIS SECTION IS BLANK INTENTIONALLY

### 1.D.2 **Colorado to Grand Island (102+00 to 312+10)**

For 3R improvements, the following policies should be applied. If not, document the circumstances and rationale for the decision and place in the project file, along with **ADE** approval.

- 1) Maintain existing outside surfaced shoulder widths
- 2) Trench widen inside surfaced shoulders to four feet with added beveled edge where needed
- 3) Add rumble strips to surfaced shoulders
- 4) Update guardrail to MASH criteria
- 5) Modify bridge buttress height to 35 inches
- 6) Maintain existing cross-section geometrics
- 7) For culverts large enough to be considered an obstacle and currently
  - a) protected with guardrail, extend the culvert to 35 feet from the edge of the traveled way and eliminate the guardrail
  - b) not protected with guardrail, but closer than 35 feet from the edge of the traveled way, analyze to determine the cost-effectiveness of extending or shielding

### 1.D.3 Grand Island to Lincoln (312+10 to 395+62)

For 3R improvements, the following policies should be applied. If not, document the circumstances and rationale for the decision and place in the project file, along with **ADE** approval.

- 1) Maintain existing outside surfaced shoulder widths
- 2) Add beveled edge to the inside shoulder
- 3) Add rumble strips to surfaced shoulders
- 4) Update guardrail to MASH criteria
- 5) Modify bridge buttress height to 35 inches
- 6) Maintain existing cross-section geometrics
- 7) For culverts large enough to be considered an obstacle and currently
  - a) protected with guardrail, extend the culvert to 35 feet from the edge of the traveled way and eliminate the guardrail
  - b) not protected with guardrail, but closer than 35 feet from the edge of the traveled way, analyze to determine the cost-effectiveness of using in place, extending, or shielding
- 8) Limit bridge improvements to 3R repairs (See Section 1.C of this chapter) or maintenance activities (See Chapter One: Roadway Design Standards, Section 6.C, of this manual)
- 9) Avoid lane closures for bridge work between 6 a.m. Friday and 9:00 p.m. on Sunday and during Holidays
- 10) Avoid bridge construction activities that require daytime lane closures
- 11) Limit lane closures for pavement repairs and overlays and shouldering work to nighttime hours
- 12) Request a design relaxation for Bridge widths that do not meet 3R *MDS* criteria (Ref. 17.1) for bridge width (See Chapter One: Design Standards, Section 10, of this manual)

### 1.D.4 Lincoln to Omaha (395+62 to 455+31)

THIS SECTION IS BLANK INTENTIONALLY

### 1.E 3R Standards for Expressways with Access Only at Interchanges

In response to the January 3, 2022, amendments to 23 CFR 625 (see Chapter One: Roadway Design Standards, Section 1.A.1 of this manual), and in accordance with a Memorandum of Understanding between **NDOT** and the **Board of Classifications and Standards (Board)**, executed on August 22, 2023 (<https://dot.nebraska.gov/media/2nvj4ir2/ndot-practical-design2023-1.pdf>), Policy DES 23-02 will allow **NDOT** to use newly established 3R (Resurfacing, Restoration, and Rehabilitation) Standards for projects on highway segments functionally classified as Expressway, but limited to such expressway segments that allow access only from interchanges (the national functional classification is Freeway) (See EXHIBIT 17.1). For purposes of this policy, as noted in EXHIBIT 17.1, the design standard allowing “existing” refers to design features as per the most recent New or Reconstructed project on the segment of the expressway.

Policy DES 23-02 is expected to be an interim measure until completion of an expected revision to the *MDS* (Ref. 17.1) expressly allows 3R Standards for the applicable Expressway projects.

#### **General Conditions applicable to this Policy**

- (1) It is understood that it is appropriate to allow 3R Standards on Expressway Projects because the expressway segments on which the 3R projects will be constructed were initially designed and constructed to modern and well accepted design standards. Allowing 3R projects on these highway segments is also practical because it allows **NDOT** to extend the useful life of these modern expressway segments.
- (2) As a part of the development of a 3R Expressway Project, **NDOT** will complete a crash history review using a standard crash analysis model to determine whether there is any existing significant need for making additional improvements with the project related to any **Board** non-complying geometric feature. Any geometric change made from this analysis would meet or exceed 3R standards for that geometric feature.
- (3) Policy 22-03, “Bridge or Culvert Replacement Projects” (see Section 1.H of this chapter) may also be used to make bridge or culvert improvements as a part of an Expressway 3R Project.
- (4) If **NDOT** decides to replace a bridge or a culvert under Policy 22-03 on a State Expressway within the corporate limits of a **Municipality**, **NDOT** will coordinate with the **Municipality** through normal processes.

If the above conditions are not met, then **NDOT** would not move forward with an Expressway 3R project; in that case, **NDOT** reserves the right to request a relaxation of standards from the **Board** (see Chapter One: Roadway Design Standards, Section 10.B, of this manual).

**State Functional Classification: Expressway (Access Only At Interchanges)**  
**National Functional Classification: Principal Arterial – Other Freeways and Expressways**

Design Speed	Posted Speed Limit
Lane Width	12 ft.
Shoulder Width	4-Lane: Lt. = 3 ft. pvd/Rt. = 8 ft. pvd ≥ 6-Lane: Lt. = Existing/Rt. = 8 ft. pvd
<b>Horizontal Alignment</b>	
Maximum Superelevation	8%
Minimum Radius (Based on Maximum Superelevation)	Existing
<b>Vertical Alignment</b>	
Crest K Value	Existing
Sag K Value	Existing
Maximum Grade	Existing
Stopping Sight Distance	Existing
<b>Cross Slope</b>	
Lane	1.5% to 2.5% (D)
Shoulder	2% to 6% (B)
<b>Clear Zone</b>	
Fixed Obstacle Clearance	Existing (5)
Lateral Offset to Obstruction	Nominal Shoulder Width (P)
Vertical Clearance	16 ft. (7)

<b>Bridges</b>	
Clear Bridge Width	37.5 ft. (N)
Structural Capacity	(F)

**Note: “Existing” refers to design features as per the most recent construction plans.**

<p>(5) This area, measured from the edge of the through travel lane, may have crashworthy or break-away obstacles and shall be free of non-shielded obstacles except:</p> <ol style="list-style-type: none"> <li>1. Traffic signal poles, railroad signals, railroad tracks, bridge rails, ditches, side slopes, driveways, intersections, bike/pedestrian paths, earth dikes, parallel drainage culverts, curbs, raised islands, guardrails, median barriers, crash cushions, drainage inlets, drainage flumes, culverts with flared end sections, erosion control devices, fire hydrants, and traffic control devices;</li> <li>2. Other obstacles if the NDOT, in its sole discretion, determines based upon an accident review and a Roadside Safety Analysis Program (RSAP) review or a comparable AASHTO approved economic analysis, that the cost to remove or treat such obstacle exceeds the benefits from such removal or treatment.</li> </ol> <p>(7) Vertical clearance shall be provided over the entire roadway including traveled lanes and paved shoulder width. For sign trusses and pedestrian overpasses, the vertical clearance is 1 ft. greater.</p> <p>(B) The surfaced shoulder slope should not be less than the slope of the adjacent lane.</p> <p>(D) On roadways where there are more than two lanes inclined in the same direction, the cross slope may be increased by 0.5% to 1% for each additional lane, up to a maximum of 3%.</p> <p>(F) The Design Loading used shall be the original design loading or, if unknown, use HS20.</p> <p>(N) For rehabilitated bridges it is desirable to use the new and reconstructed clear bridge width.</p> <p>(P) The “nominal shoulder width” is defined as the shoulder width presented in this table.</p>
---

**Exhibit 17.1a 3R Standards for Municipal Expressway (Access Only At Interchanges)**

**State Functional Classification: Expressway (Access Only At Interchanges)**  
**National Functional Classification: Principal Arterial – Other Freeways and Expressways**

Design Speed	Posted Speed Limit
Lane Width	12 ft.
Shoulder Width	4-Lane: Lt. = 3 ft. pvd/Rt. = 8 ft. pvd ≥ 6-Lane: Lt. = Existing/Rt. = 8 ft. pvd
<b>Horizontal Alignment</b>	
Maximum Superelevation	8%
Minimum Radius (Based on Maximum Superelevation)	Existing
<b>Vertical Alignment</b>	
Crest K Value	Existing
Sag K Value	Existing
Maximum Grade	Existing
Stopping Sight Distance	Existing
<b>Cross Slope</b>	
Lane	1.5% to 2.5% (D)
Shoulder	2% to 6% (B)
<b>Clear Zone</b>	
Fixed Obstacle Clearance	Existing (5)
Lateral Offset to Obstruction	Nominal Shoulder Width (P)
Vertical Clearance	16 ft. (7)

<b>Bridges</b>	
Clear Bridge Width	37.5 ft. (N)
Structural Capacity	(F)

**Note: “Existing” refers to design features as per the most recent construction plans.**

- (5) This area, measured from the edge of the through travel lane, may have crashworthy or break-away obstacles and shall be free of non-shielded obstacles except:
1. Traffic signal poles, railroad signals, railroad tracks, bridge rails, ditches, side slopes, driveways, intersections, bike/pedestrian paths, earth dikes, parallel drainage culverts, curbs, raised islands, guardrails, median barriers, crash cushions, drainage inlets, drainage flumes, culverts with flared end sections, erosion control devices, fire hydrants, and traffic control devices;
  2. Other obstacles if the NDOT, in its sole discretion, determines based upon an accident review and a Roadside Safety Analysis Program (RSAP) review or a comparable AASHTO approved economic analysis, that the cost to remove or treat such obstacle exceeds the benefits from such removal or treatment.
- (7) Vertical clearance shall be provided over the entire roadway including traveled lanes and paved shoulder width. For sign trusses and pedestrian overpasses, the vertical clearance is 1 ft. greater.
- (B) The surfaced shoulder slope should not be less than the slope of the adjacent lane.
- (D) On roadways where there are more than two lanes inclined in the same direction, the cross slope may be increased by 0.5% to 1% for each additional lane, up to a maximum of 3%.
- (F) The Design Loading used shall be the original design loading or, if unknown, use HS20.
- (N) For rehabilitated bridges it is desirable to use the new and reconstructed clear bridge width.
- (P) The “nominal shoulder width” is defined as the shoulder width presented in this table.

**Exhibit 17.1b 3R Standards for Rural Expressway (Access Only At Interchanges)**

## 1.F 2+2 Projects

This section defines criteria for a 2+2 Project (i.e. designing and constructing two new lanes adjacent to an existing two-lane highway facility to create a four-lane corridor).

The existing lanes along the corridor remain on existing alignment and will be preserved using a 3R strategy for the functional classification of the existing roadway. The new lanes will meet the New and Reconstructed Standards that apply to the functional classification of the roadway (See Chapter Six: The Typical Roadway Cross-Section, Section 8, of this manual).

### 1.F.1 **2+2 Project Safety**

In general, 2+2 projects increase the posted speed of the highway. This increase necessitates an evaluation of the geometry of the existing lanes for compliance with standards and guidance, to include crash mitigation measures as agreed to by the **Roadway** and **Traffic Engineering** and to evaluate the practicability of these enhancements. In addition to the evaluation performed by **Traffic Engineering, Roadway** shall review the following:

- Existing driveways will be considered for consolidation or conversion to right in and right out and should undergo review with the **District** as well as the **Access Control Team**. See Chapter 15, Right of Way, Section 3, of this manual for Access Control review.
- New and existing frontage roads should be considered for design or modification, **District** should be consulted for the design and/or modification of frontage roads. See Chapter 4, Intersections, Driveways, and Channelization, Section 1.B.4, of this manual for design and use of Frontage Roads.
- Existing intersections should be evaluated for intersection sight distance based on the proposed conditions (See Section 9.5 of A Policy on Geometric Design of Highways and Streets (*Green Book*), Ref. 17.5).

### 1.F.2 **2+2 Project Bridges**

**Bridge** and **Roadway** will coordinate to determine the scope of the bridge work. As part of a 2+2 project, existing bridges may be rehabilitated, repaired, widened, and/or replaced at the existing elevation based on the bridges in-service performance. The **Bridge Hydraulics Section** will be required to review the existing lanes and new lanes as a system to determine the appropriate bridge hydraulic conveyance needs and balance the bridge needs to the needs of the overall 2+2 project.

### 1.F.3 **2+2 Project Lighting**

Within the 2+2 project limits, lighting should be evaluated as if it were a New and Reconstruction Project for both the existing and added lanes. See Chapter Ten: Miscellaneous Design Issues, Section 13, of this manual for additional information.

#### 1.F.4 2+2 Cross-Section Alternatives

The roadway designer shall develop two primary cross-section alternatives to determine the impacts of constructing additional lanes on either side of existing alignment. In the development of these cross-section alternatives, it is preferred to construct the additional lanes on a single side of the existing alignment and to minimize reconstruction and crossing over the existing lanes. Any alternative that necessitates the shifting of the new lanes from one side to the other will require additional analysis be conducted by the roadway designer. This analysis will include a recommendation from **Traffic Engineering**, geometric review, constructability review, associated cost comparisons, and other potential impacts (e.g. environmental, right-of-way, earthwork). The roadway designer shall prepare a decision document, for approval by the **Roadway Design Engineer**, for any shift in the new lanes from one side of the existing highway to the other.

#### 1.G Super 2 Projects

Super 2 projects add passing lanes, in strategic locations, to an existing two-lane roadway. The objectives of adding passing lanes to an existing two-lane roadway are to reduce delay, improve overall traffic operations, and improve safety. The objectives are consistent with the objectives of Resurfacing, Restoration, and Rehabilitation (3R) projects, thus improving an existing two-lane highway to a Super 2 highway is defined as a 3R improvement.

##### 1.G.1 Objectives of Adding Passing Lanes

Passing lanes are a unique improvement for two-lane highways because they can improve the level of service (LOS) for the roadway but do not increase the roadway capacity. The capacity of the roadway is controlled by the typical roadway segment, with only one lane for each direction of travel. In general, the Highway Capacity Manual (Ref. 17.6) specifies a maximum capacity of 3,200 passenger cars/hour for both directions combined on two-lane roadways, regardless of whether passing lanes are present.

##### 1.G.2 Location Guidelines for Passing Lanes

Location guidelines for passing lanes are as follows:

- a. Passing lanes should generally be placed where traffic platooning is highest. It may be desirable to place passing lanes just downstream of a town, a major intersection, or a series of horizontal curves so that any platoons formed in those areas can be dissipated.
- b. Passing lanes should be placed, when practicable, at locations where there is a substantial length of uninterrupted roadway downstream where traffic operational benefits can be obtained. For example, it generally would not make sense to locate a passing lane just upstream of a town because the potential downstream benefits of the passing lane might be quickly dissipated as traffic passes through the town.
- c. It is also desirable in locating passing lanes to avoid sensitive environmental areas, such as wetlands, and areas of historical or archeological interest.
- d. The passing lane location should appear logical to the driver. The value of passing lanes is more obvious to the driver at locations where passing sight distance is restricted than on long tangent sections which already provide good passing opportunities.
- e. The choice of passing lane location should be designed with above-minimum stopping sight distance at the lane-addition and lane-reduction tapers.



- f. The location of major intersections and high-volume driveways should be considered in selecting passing lane locations to minimize the volume of turning movements on a roadway section where passing is encouraged. Where the presence of higher-volume intersections or driveways cannot be avoided, special provisions for turning vehicles, such as auxiliary turn lanes, should be considered. Low-volume intersections and driveways do not usually create problems within passing lanes; however, it is desirable to avoid locating the lane-addition and lane-reduction transitions near intersections or driveways, since turning movements are not desirable where drivers may be focused on changing lanes. Other physical constraints, such as bridges and culverts, should be avoided, where practical, if their presence increases the construction cost or restricts the provision of a continuous shoulder.

### 1.G.3 Geometric Design of Passing Lanes

Geometric design of passing lanes should consider lane and shoulder widths, other cross-section elements, lane-addition and lane-reduction taper designs, and intersection treatments.

- 1) The width for all lanes on Super 2 roadways, including passing lane sections, should be 12 feet.
- 2) The surfaced shoulder width adjacent to passing lanes along Super 2 highways should be built to the following widths:
  - a) Design year ADT greater than or equal to 4,000 vehicles/day: six-foot minimum surfaced shoulder width
  - b) Design year ADT less than 4,000 vehicles/day: four-foot minimum surfaced shoulder width
- 3) The surfaced shoulder width adjacent to a Super 2 passing lane may be wider than the minimum shown above. For example, a wider shoulder may be considered for corridors with higher ADTs, for corridors with substantial pedestrian and bicycle volumes, or for Priority Commercial corridors. Also, the surfaced shoulder width may be designed to match the adjacent sections of two-lane highway. However, surfaced shoulders should be constructed to the minimum widths shown above if right-of-way constraints or potential environmental impacts justify use of the minimum width. Shoulders may be omitted next to passing lanes in curb-and-gutter sections. This shoulder width should be shown and labeled on the Typical Cross-Section Sheet(s) for the project (See Chapter Eleven: Highway Plans Assembly, EXHIBIT 11.3, of this manual).
- 4) The roadway designer should provide the fixed-obstacle clearance from the 3R MDS (Ref. 17.1) adjacent to a new passing lane. This distance should be shown and labeled on the main typical section for the project. A minimum 1:3 slope should be used for the new foreslope between the shoulder point and the existing embankment or ditch. Where practicable, based on right-of-way constraints and potential environmental impacts, the roadway designer may maintain the clear zone distance that was built in a previous New and Reconstruction project. Foreslopes steeper than 1:3 should be avoided, except where a traffic barrier is provided.
- 5) The recommended minimum length for a passing lane is 1,000 feet, not including the taper lengths.
- 6) The recommended maximum passing lane length is 2.0 miles, not including the tapers.
- 7) Based on current Nebraska practice for climbing lanes, the lane addition taper for passing lanes should use a taper rate of 1:50.

- 8) The lane-reduction transition area of a passing lane should use a minimum taper rate of 1:50. In most cases, the outside lane will be dropped, and traffic will move to the inside lane, but in specific cases where it is found to be appropriate, the inside lane may be dropped, and traffic will move to the outside lane.

Directional flow rate (pc/h)	Optimal passing lane length (mi)
100	0.50
200	> 0.50-0.75
400	> 0.75-1.00
≥ 700	> 1.00-2.00

NOTE: The units, pc/h, based on the Highway Capacity Manual (Ref. 17.6), represent passenger car equivalents per hour. The passenger car equivalent volume is the traffic volume in vehicles/hour, with greater weight given to trucks than passenger cars.

### Exhibit 17.2 Optimal Lengths of Passing Lanes

#### 1.G.4 Average Passing Lane Spacing

Average passing lane spacing tables are shown below. Highway Capacity Manual (Ref. 17.6) procedures were used to develop these values. These tables are typically meant for planning purposes. Traffic operations analyses should be conducted in conjunction with safety analyses for specific applications. Since these tables are recommended for planning purposes, interpolation of values in these tables should be done conservatively. The spacings shown are from the beginning of one passing lane to the beginning of the next passing lane, excluding the tapers. Tables are divided for different truck percentages, percent no passing zones, and terrain type.

Target LOS	Percent Trucks	Two-Way AADT (veh/day)									
		1000	2000	3000	4000	5000	6000	7000	8000	9000	10000
<b>30% No Passing Zones, Level Terrain</b>											
B-	10%	No PL	No PL	No PL	No PL	>60.0	33.5	16.5	11.0	8.0	6.5
	20%	No PL	No PL	No PL	No PL	>60.0	31.5	16.0	11.0	8.0	6.5
	30%	No PL	No PL	No PL	No PL	>60.0	31.0	16.0	9.5	8.0	6.5
B	10%	No PL	No PL	No PL	No PL	28.0	15.5	10.0	7.0	5.0	3.5
	20%	No PL	No PL	No PL	No PL	28.0	15.0	10.0	7.0	5.0	3.5
	30%	No PL	No PL	No PL	No PL	27.5	15.0	10.0	6.5	5.0	3.5
B+	10%	No PL	No PL	No PL	26.5	14.0	9.5	5.5	3.5		
	20%	No PL	No PL	No PL	26.5	14.0	9.5	5.5	3.5		
	30%	No PL	No PL	No PL	25.5	14.0	9.5	5.5	3.0		
A	10%	No PL	No PL	43.0	13.5	7.5	4.0				
	20%	No PL	No PL	41.0	13.5	7.5	4.0				
	30%	No PL	No PL	39.0	13.0	7.5	4.0				
<b>50% No Passing Zones, Level Terrain</b>											
B-	10%	No PL	No PL	No PL	>60.0	35.5	19.0	13.0	9.0	7.0	5.5
	20%	No PL	No PL	No PL	>60.0	35.5	19.0	13.0	9.0	7.0	5.5
	30%	No PL	No PL	No PL	>60.0	34.5	19.0	12.5	8.5	7.0	5.5
B	10%	No PL	No PL	No PL	28.5	16.5	12.0	8.0	6.0	4.0	2.5
	20%	No PL	No PL	No PL	28.5	16.5	12.0	8.0	6.0	4.0	2.5
	30%	No PL	No PL	No PL	28.0	16.0	11.5	8.0	5.0	4.0	2.5
B+	10%	No PL	No PL	47.0	14.5	10.0	7.0	4.0	2.5		
	20%	No PL	No PL	45.5	14.5	10.0	6.5	4.0	2.5		
	30%	No PL	No PL	43.5	14.5	10.0	6.5	4.0			
A	10%	No PL	No PL	16.5	8.5	4.0					
	20%	No PL	No PL	16.5	8.5	4.0					
	30%	No PL	No PL	16.0	8.0	4.0					
<b>70% No Passing Zones, Level Terrain</b>											
B-	10%	No PL	No PL	No PL	57.0	25.0	16.5	11.5	8.5	6.5	5.0
	20%	No PL	No PL	No PL	56.5	25.0	16.0	11.5	8.5	6.5	5.0
	30%	No PL	No PL	No PL	55.5	24.5	16.0	11.5	8.0	6.5	5.0
B	10%	No PL	No PL	No PL	20.5	14.0	10.5	7.0	5.5	3.5	2.5
	20%	No PL	No PL	No PL	20.5	14.0	10.5	7.0	5.5	3.5	2.5
	30%	No PL	No PL	No PL	20.0	13.5	10.0	7.0	4.5	3.5	2.5
B+	10%	No PL	No PL	27.0	12.5	8.5	5.5	3.0			
	20%	No PL	No PL	26.5	12.5	8.0	5.5	3.0			
	30%	No PL	No PL	26.0	12.0	8.0	5.5	3.0			
A	10%	No PL	>60.0	13.5	6.5	2.5					
	20%	No PL	58.0	13.5	6.5	2.5					
	30%	No PL	55.5	13.0	6.0	2.5					

Assumptions:

- 1-mi passing lane length
- Percent of traffic in peak hour (k) = 0.09
- Peak-hour factor (PHF) = 0.90
- Directional split (D) = 0.50

Notes:

- No PL = no passing lanes needed to achieve target LOS
- Shaded area = target LOS cannot be achieved with passing lanes of specified length

**Exhibit 17.3 Average Passing Lane Spacing (mi) Needed to Meet Specific LOS Targets on Two-Lane Highways in Level Terrain**  
 (Source: Highway Capacity Manual, Ref. 17.6)

Target LOS	Percent Trucks	Two-Way AADT (veh/day)									
		1000	2000	3000	4000	5000	6000	7000	8000	9000	10000
<b>30% No Passing Zones, Rolling Terrain</b>											
B-	10%	No PL	No PL	No PL	>60.0	23.0	13.5	9.5	7.5	6.5	5.5
	20%	No PL	No PL	No PL	37.0	18.0	11.0	9.0	7.0	6.0	5.5
	30%	No PL	No PL	No PL	30.0	14.0	9.5	7.5	6.0	5.5	5.0
B	10%	No PL	No PL	No PL	20.0	13.0	8.5	6.5	4.5	3.5	3.0
	20%	No PL	No PL	54.0	16.0	11.0	7.0	5.5	4.0	3.5	2.5
	30%	No PL	No PL	30.0	15.0	8.5	6.5	4.5	3.5	3.0	2.5
B+	10%	No PL	No PL	25.0	12.0	7.5	4.5	3.0			
	20%	No PL	No PL	18.5	10.0	6.5	3.5	2.5			
	30%	No PL	No PL	15.0	9.0	4.5	3.0				
A	10%	No PL	50.5	13.0	6.0	2.5					
	20%	No PL	27.5	10.5	4.5						
	30%	No PL	20.0	8.5	4.0						
<b>50% No Passing Zones, Rolling Terrain</b>											
B-	10%	No PL	No PL	>60.0	25.5	15.5	11.0	8.5	6.5	5.5	5.0
	20%	No PL	No PL	59.5	19.5	13.5	9.0	7.5	6.0	5.5	4.5
	30%	No PL	No PL	39.5	18.5	11.0	8.5	6.5	5.0	5.0	4.5
B	10%	No PL	No PL	27.5	14.0	10.0	7.0	5.0	3.5	2.5	2.0
	20%	No PL	No PL	21.0	12.0	8.5	6.0	4.5	3.0	2.5	
	30%	No PL	No PL	17.5	11.5	7.0	5.0	3.5	2.5	2.0	
B+	10%	No PL	53.5	14.5	8.5	5.5	3.0				
	20%	No PL	29.5	12.5	7.0	4.5	2.5				
	30%	No PL	22.5	10.5	6.5	3.0					
A	10%	No PL	18.0	8.0	3.0						
	20%	No PL	14.0	6.5							
	30%	No PL	12.0	5.0							
<b>70% No Passing Zones, Rolling Terrain</b>											
B-	10%	No PL	No PL	54.5	19.5	14.0	10.0	8.0	6.0	5.0	4.5
	20%	No PL	No PL	36.0	16.5	12.5	8.5	7.0	5.5	5.0	4.5
	30%	No PL	No PL	26.0	16.0	10.0	8.0	6.0	5.0	4.5	4.0
B	10%	No PL	No PL	20.0	12.0	9.0	6.0	4.5	3.0	2.5	
	20%	No PL	No PL	17.0	10.5	8.0	5.5	4.0	3.0	2.0	
	30%	No PL	44.0	14.5	10.0	6.5	4.5	3.0	2.0		
B+	10%	No PL	29.5	12.0	7.0	4.5	2.5				
	20%	No PL	21.0	10.5	5.5	3.5					
	30%	No PL	17.5	9.0	5.5	2.0					
A	10%	No PL	14.5	6.0							
	20%	No PL	12.0	4.5							
	30%	No PL	10.0	3.5							

Assumptions:

- 1-mile passing lane length
- Percent of traffic in peak hour (k) = 0.09
- Peak-hour factor (PHF) = 0.90
- Directional split (D) = 0.50

Notes:

- No PL = no passing lanes needed to achieve target LOS
- Shaded area = target LOS cannot be achieved with passing lanes of specified length

**Exhibit 17.4 Average Passing Lane Spacing (mi) Needed to Meet Specific LOS Targets on Two-Lane Highways in Rolling Terrain (Source: Highway Capacity Manual, Ref. 17.6)**

## 1.H Practical Design: Bridge or Culvert Replacement Projects

Policy DES 22-03, January 2023, provides flexibility in the application of Nebraska’s highway design standards in accordance with a Memorandum of Understanding between **NDOT** and the **Board of Public Roads**, executed on October 26, 2022 (<https://dot.nebraska.gov/media/xwalmslw/ndot-program.pdf>). This policy provides for (a) complete replacement of a single structure or multiple structures (bridges, non-buried structures, and/or culverts), or (b) for structure replacement(s) (bridges, non-buried structures, and/or culverts) done as part of a Resurfacing, Restoration and Rehabilitation (3R) work or project when the conditions of this policy are satisfied.

### 1.H.1 Standards and Intent

Unless stated otherwise, reference to the **Board of Public Roads’** standards or current standards refers to the *MDS* (Ref. 17.1) standards in effect during the design phase of a project or work. The intent of projects and works done under this policy is to design and build as close to the *MDS* (Ref. 17.1) New & Reconstructed geometric design standards as practicable – in the judgement of **NDOT** – but not to build below the *MDS* (Ref. 17.1) 3R geometric design standards. Under this policy, the design of the replacement culvert(s), bridge(s), or non-buried structure(s) shall be as follows (“existing” refers to design features as per the most recent construction plans).

#### **General Conditions:**

- 1) There has been a 3R or New & Reconstructed project completed that conformed to *MDS* (Ref. 17.1) standards, since 1985, at the location of each culvert(s), bridge(s), or non-buried structure(s) to be replaced, i.e., the highway has been previously improved, and
- 2) **NDOT** has completed a recent crash history review using a standard crash analysis model at and near each bridge or culvert location, and that study does not reveal a crash history related to a *MDS* (Ref. 17.1) non-complying geometric feature.

#### **Replacement Bridges or Non-Buried Structures:**

- A. Shall meet the *MDS* (Ref. 17.1) New & Reconstructed standard for structural capacity.
- B. Will meet current **NDOT** hydrologic and hydraulic conditions (not a **Board of Public Roads** standard), see Chapter One of the Drainage Design and Erosion Control Manual (*Drainage Manual*, Ref. 17.8) (<https://dot.nebraska.gov/media/qhubv1ji/d-chap-one-drainage.pdf>)
- C. Roadways approaching and adjacent to the bridge or non-buried structure within project or work termini will
  - Match existing lane width, shoulder width, and paved shoulder width (see I. in **Other Conditions and Clarifications**, below) and
  - Transition horizontal and vertical alignment from the replacement bridge or non-buried structure into (1) existing alignment, or (2) meeting or exceeding *MDS* (Ref. 17.1) 3R standards, whichever is the greater (either 1 or 2)

**Replacement Culvert (Buried Structures, even if greater than the 20-foot span width):**

- A. Shall meet the *MDS* (Ref. 17.1) New & Reconstructed standard for structural capacity.
- B. Will meet current **NDOT** hydrologic and hydraulic conditions (not a **Board of Public Roads'** standard), see Chapter One of the *Drainage Manual* (Ref. 17.8)
- C. Roadways within project or work termini will
  - (1) Match existing lane width, shoulder width, paved shoulder width, and fixed obstacle clearance or (2) meet or exceed *MDS* (Ref. 17.1) 3R standards, whichever is the greater (either 1 or 2), and
  - Transition horizontal and vertical alignment from culvert replacement into (1) existing alignment, or (2) meeting *MDS* (Ref. 17.1) 3R standards, whichever is the greater (either 1 or 2)

**Other Conditions and Clarifications:**

- I. For a bridge or non-buried structure replacing a bridge or non-buried structure, the clear bridge width shall at least match the approach geometry. For example, if lane widths are 12 feet wide, and shoulders are six feet wide, the design clear bridge width will be 36 feet (see the first bullet in C, above)
- II. There shall be no significant changes expected in the foreseeable future for (a) land use along the highway or change in highway functional classification, or (b) traffic volume, i.e., volumes are expected to stay within the highway segment's current ADT category within the *MDS* (Ref. 17.1) New & Reconstructed minimum standards.
- III. If **NDOT** decides to replace a bridge or culvert under this policy on a state or federal highway within the corporate limits of a **Municipality**, **NDOT** will coordinate with the **Municipality** through normal processes.
- IV. The **Board of Public Roads** will not require specifically and separately tracked documentation concerning the cost savings for use of this program, in part because **NDOT's** planning and design process has several built-in processes, reports, and documentation that will confirm that a project or work is eligible for this program, including the Plan-in-Hand decision making process of the **District Engineer**, **Roadway Design Engineer**, and other key staff. **NDOT** will include or add the savings from this program with or into the current practical design savings reports that are reported annually to the **Director** of **NDOT**. The **Board of Public Roads** may ask for a report on these savings periodically from **NDOT**.

If the above conditions are not met, **NDOT** would not move forward with a Bridge or Culvert replacement project or work under this policy; in that case **NDOT** may request a relaxation of standards from the **Board of Public Roads** and a design exception from the appropriate **FHWA/NDOT** level of authority (See Chapter One: Roadway Design Standards, Section 10, of this manual).

## 2. 3R DESIGN PROCESS

### 2.A Initial Processing of Asset Preservation Projects

System preservation projects are initially separated into two categories, Maintenance and 3R. The categorization is based on the thickness of the pavement strategy, as recommended by **M&R**. If during the design process it is determined that the project goals cannot be met within the defined category the roadway designer, with **Unit Head** approval, should request **M&R** provide for further processing:

- i) up to 12 years of pavement life
  - a) Processed by **Roadway** as a Preventive Maintenance project.
- ii) 12 to 20 years of pavement life
  - a) Processed by **Roadway**.
  - b) Initially assumed to be a 3R scope of work, with the application of 3R standards.

For additional information, see Section 1.A of this chapter.

### 2.B Asset Preservation Templates

In general, 3R projects are developed and assigned on three activity templates: the 3R with ROW template, the 3R without ROW template, and an M&R template.

1. The 3R with ROW template is used for projects which require a substantial level of design and where updating the roadway to 3R standards will require the purchase of right-of-way. These projects are usually assigned to a unit in **Roadway** or to a **Consultant**.
2. The 3R without ROW template is used for projects which require a substantial level of design but where updating the roadway to 3R standards can be accomplished within the existing right-of-way. These projects are usually assigned to a unit in **Roadway** or to a **Consultant**.
3. Roadway Design Preventive Maintenance template projects (See Chapter One: Roadway Design Standards, Section 6.C.2) maintain the existing roadway to its original condition, maintain a minimum condition of bridges, maintain, and in some instances upgrade, roadside appurtenances such as guardrail, and may include ADA accessibility work. These projects do not typically require a substantial level of design, are accomplished within the existing right-of-way, and are usually assigned to a unit in **Roadway**.
4. The M&R Maintenance Template is used for those projects that have primarily asset preservation needs where repair is needed to maintain the mobility within the highway corridor. These projects generally do not require guardrail updates or ADA work and do not require a **City** or **County** agreement. The activities for these projects will be assigned to **M&R**. The title sheet of the plans will indicate Maintenance and will be signed by the **M&R Division Engineer** as Coordinating Professional. For additional information, see Chapter One: Roadway Design Standards, Section 6.C, of this manual.

## 2.C Preliminary Roadway Design

The preliminary design phase develops the engineering design and evaluation, defined by the project's description and scope, in collaboration with other stakeholders within **NDOT** (e.g. **Right-of-Way Division (ROW)**, **Utilities Unit in Roadway (Utilities)**, **Project Development Division (PDD)**, **Program Management, M&R, Construction Division (Construction)**, **Traffic Engineering**). Such collaboration will support and identify the best decision-making process and preferred design alternative. Preliminary design is instrumental to time-effectiveness and cost-effectiveness, impacting highway planning and design.

During the preliminary design process, the project schedule and milestones should be monitored. The environmental process is a critical step in keeping a project on schedule throughout the preliminary design phase. Close coordination is important for a complete evaluation of a project in order to avoid the need for environmental re-evaluations, which could delay a projects' schedule.

**Roadway Design** will hold Project Coordination Meetings (PCM) during the preliminary design phase (See the Design Process Outline (DPO), Ref. 17.7 (<https://dot.nebraska.gov/business-center/design-consultant/>), and Appendix K, "Project Coordination Meetings", of this manual). The participants of these meetings will review, identify and address a projects' scope, traffic maintenance and phasing, environmental class, NEPA, environmentally sensitive areas, mitigation measures, and environmental commitments.

Once all the issues have been addressed and there are no more changes to the scope or design of the project, the NEPA process can be finished and the Roadway Design Details process can begin. A final PCM is held to review all the environmental commitments and the projects' ultimate design.

## 2.D Plan-in-Hands

The roadway designer will notify **District** that the Plan-in-Hand Plans and the "Plan-In-Hand Checklist" are available in OnBase (See Chapter Eleven: Highway Plans Assembly, EXHIBIT 11.2, of this manual). The need for **Roadway** participation on a plan-in-hand will be determined on a project-by-project basis by the **Unit Head** in conjunction with the **District**. In general, plan-in-hand inspections will not be required on projects being developed with a M&R development schedule. Individual projects may dictate a need to visit a project or to have the **District** conduct an inspection. If a plan-in-hand is held, the roadway designer should request the **District** to provide a list of issues to be considered on the plan-in-hand visit including hydraulic, traffic operations, and maintenance issues.

Work beyond pavement preservation on a 3R project (e.g. added turn lanes or spot safety improvements) which was not included on the **NDOT Form 73** should be noted as a change in the plan-in-hand report and requires the approval of the **Roadway Design Engineer**. The roadway designer is responsible for writing the plan-in-hand report.

For additional information, see the *DPO* (Ref. 17.7), Phase 3: Design, Activity 5300, Clarity Task Codes 5380 and 5388.



### 3. ROADWAY ALIGNMENT

#### 3.A Vertical Alignment Design

##### 3.A.1 Vertical Curve

Improving vertical curvature is not typical on a 3R project. An improvement may be considered if there is relevant crash history (the roadway designer will review recommendations provided by **Traffic Engineering**). Improving a vertical curve should have a greater benefit than cost, as documented by a benefit/cost analysis (See the introductory commentary “Analyses of Benefits Versus Costs” of this chapter).

The roadway designer will use the K values from **TABLES 3-35** and **3-37** of the *Green Book* (Ref. 17.5) when checking the existing vertical alignment against the 3R standards in the *MDS* (Ref. 17.1) for stopping sight distance. If the determination is to improve the vertical curve, the re-designed vertical curve shall meet (or exceed) the 3R standards in the *MDS* (Ref. 17.1).

If the existing vertical curve is perpetuated, and does not meet the 3R standards in the *MDS* (Ref. 17.1), a design relaxation must be obtained (See Chapter One: Design Standards, Section 10.B, of this manual).

If a vertical curve is perpetuated at less than the posted speed limit, the **District** and **Traffic Engineering** will be advised, through the PIH Report, of the computed maximum allowable speed.

##### 3.A.2 Grade

The existing vertical grade should not be modified unless an improvement is made to the vertical curve (See Section 3.A.1 of this chapter). The existing grade should be evaluated to determine any locations where a horizontal grade and superelevation may not provide adequate slope (cross slope and running slope) for roadway runoff (See Chapter Three: Roadway Alignment, Section 3.A.2, of this manual).

Before the plan-in-hand field inspection the roadway designer should:

1. List segments of the roadway which are on the low side of superelevated curves and/or which have grades between 2% and 3.5% and a list of all roadway grades greater than 3.5% and evaluate erosion control techniques for these segments with the **Roadside Development & Compliance Unit Supervisor** in **PDD**.
2. Review grades over 3.5% for the inclusion of curb and flume. See the *Drainage Manual* (Ref. 17.8), Chapter Two: Erosion and Sediment Control, Section 7.E.
3. Avoid installation of new curb and flume locations on 3R projects when it involves acquiring environmental permits and the acquisition of property rights on a project where right-of-way activities are not included. For additional tactics to mitigate erosion, contact the **Roadside Development & Compliance Unit** in **PDD**.
4. Evaluate new and existing curb locations for potential ponding on the traveled way. If ponding is identified as a potential occurrence, consider remedial actions consistent with the *Drainage Manual* (Ref. 17.8), Chapter One: Drainage, Sections 9 and 10.

The roadway designer should consider adding passing lanes on 3R projects if warranted by a safety analysis and recommended by **Traffic Engineering**. The passing lane should be designed using the criteria presented in Section 1.G of this chapter and in Chapter 3: Roadway Alignment, Section 3.A.4, of this manual.

### **3.A.3 Vertical Taper Rates**

The Vertical Taper Rates for overlays and transitions shall be consistent with Chapter Eight: Surfacing, Section 5.D, of this manual.

### **3.B Horizontal Alignment Design**

Horizontal alignment design speed will be reviewed for the degree of curve and the superelevation rate. The horizontal degree of curve is typically not improved on a 3R project, increasing the superelevation is more likely to occur (See Section 3.B.1 of this chapter). An improvement to the horizontal alignment may be considered if there is relevant crash history (the roadway designer will review recommendations provided by **Traffic Engineering**). Improving horizontal alignment should have a greater benefit than cost, as documented by a benefit/cost analysis (See the introductory commentary “Analyses of Benefit Versus Costs” this chapter).

When considering a horizontal alignment improvement, other factors (e.g. environmental impacts, right-of-way needs) can affect the decision and may result in delaying the project. The improvement may be removed from the project and programmed as a “Phased 3R Project”, according to DOT-OI 60-16, “Policy for Phase Constructed 3R Projects” (See Appendix B, “Selected NDOT Operating Instructions” of this manual).

If the decision is to improve the horizontal alignment, the roadway designer should begin with the desirable New and Reconstruction design criteria for the horizontal curve. However, the roadway designer could review the corridor and determine if less than desirable criteria would meet the need for improving the horizontal curve and typical cross-section. The 3R standards in the *MDS* (Ref. 17.1) should be met or exceeded when proposing horizontal curve improvements. Additional measures should be considered to mitigate an identified crash history, see section 3.B.3 of this chapter.

If the existing horizontal curve does not meet the requirements of the *MDS* (Ref 17.1), a design relaxation must be obtained (See Chapter One: Design Standards, Section 10.B, of this manual) unless a design relaxation was previously granted for the horizontal curve and if circumstances (such as functional classification and ADT) have not changed significantly.

If the decision is not to improve the horizontal alignment, other measures should be considered to mitigate an identified crash history, see section 3.B.3 of this chapter.

### 3.B.1 Superelevation

The superelevation shall be reviewed by the designer and improvements considered as recommended by the **Traffic Engineering** review. For 3R projects, the superelevations being improved will be designed in accordance with Chapter Three: Roadway Alignment, Section 2.C, of this manual except as follows:

- The roadway designer should check the existing superelevation using the as-built  $e_{max}$ . In the event no as-built information is available, the  $e_{max} = 6\%$  table (See Chapter Three: Roadway Alignment, EXHIBIT 3.3c, of this manual) can be used and, if practicable, the existing superelevation should be improved to match the table.
- If the existing superelevation rate is over 6%, the existing superelevation should be checked using the  $e_{max} = 8\%$  table (**TABLE 3-10** of the *Green Book*, Ref. 17.5). An 8% superelevation will not be exceeded without the approval of the **Roadway Design Engineer**.
- For low-speed urban applications ( $V \leq 45$  mph) the roadway designer should check the superelevation using the  $e_{max} = 4\%$  table (See Chapter Three: Roadway Alignment, EXHIBITS 3.3d & TABLE 3-13 of the *Green Book*, Ref. 17.5).
- The rate of superelevation ( $e$ ) should be listed in the curve data on the plans for all curves; it is not acceptable to place the phrase "Use Existing Superelevation" on the plans.
- Existing spiral transitions should be perpetuated on 3R projects.
- Decreasing the superelevation may not be practicable and is usually unnecessary.

When superelevation correction results in a wedge that is difficult to construct (six inches or more), reducing the superelevation correction should be considered.

### 3.B.2 Pavement Widening on Curves

For 3R projects, it is desirable that a two-foot widening be added on the inside lane of a horizontal curve if all the following conditions occur:

1. The curve radius is less than 1,910 feet.
2. The operating speed is 45 mph or greater.
3. The roadway does not have surfaced shoulders.
4. The projected average daily truck traffic is more than 50 per day.

Field observations or **District** recommendation may also justify the need for pavement widening on curves.

### 3.B.3 Traffic Control Devices for Horizontal Alignment

Traffic control devices such as signs, raised pavement markings and reflective guideposts may be installed to mitigate identified crash history. Regarding advisory curve and speed signs, both the **District Engineer (DE)** and the **Traffic Engineer** will be notified by the roadway designer for the appropriate action, as follows. If the final configuration of a curve has a calculated design speed:

- a. Greater than 5 mph and less than or equal to 10 mph less than the posted speed limit, the placement of advisory curve and speed signs is *desirable*.
- b. Greater than 10 mph and less than or equal to 15 mph less than the posted speed limit, the placement of advisory curve and speed signs is *required*.

## 4. INTERSECTIONS, DRIVEWAYS AND CHANNELIZATION

### 4.A Driveways and Intersections

For 3R projects, **Traffic Engineering** will review the crash history for the entire project including intersections and driveways and, if necessary, identify mitigation methods for reducing the potential for or severity of crashes. The existing skew of an intersection will not be changed unless justified by the crash history and a cost-effectiveness analysis or if realignment is made necessary by other design features of the project.

The adequacy of intersection/driveway geometry should be reviewed and discussed prior to the plan-in-hand. If adequate, the existing intersection/driveway geometry will be matched. Intersection sight distance is considered a desirable condition on 3R projects, mitigation is not required unless there is an identified problem.

If justified based on the crash history, intersections and driveways on 3R projects may be evaluated for intersection sight distance using departure sight triangles for Case B1 (left turn from a minor road) found in Chapter 9 of the *Green Book* (Ref. 17.5). If the existing conditions do not meet the required minimum sight distance, the roadway designer should either adjust the design or inform the **District** and **Traffic Engineering** so that the approach to the intersection or driveway may be signed accordingly.

When a roadway is resurfaced, the intersections and driveways will also be resurfaced unless the **DE** indicates otherwise. The intersection/driveway surfacing material should be decided on the plan-in-hand.

- On Asset Preservation projects produced in **M&R**, **M&R** will provide the quantities and locations of the driveways and intersections.
- On Preventive Maintenance projects produced in **Roadway**, **Roadway** will provide the location and area of each driveway and intersection and **M&R** will provide the final asphalt quantities.
- On 3R projects designed and managed by **Roadway**, **Roadway** will provide the location and area of each driveway and intersection and **M&R** will provide the final asphalt quantities.
- If the resurfacing of an existing intersection/driveway which ties into rock or gravel surfacing results in a grade raise in excess of 0.5 inches, either crushed rock or gravel will be placed behind the intersection/driveway surfacing. Consult with the **DE** during the plan-in-hand to determine the unit of measurement and the type of aggregate to be used. An estimate of 10 CY for intersections and 5 CY may be used for driveways (10 tons and 5 tons respectively in **Districts 1 & 2**).
- Driveways and intersections with slopes steeper than 1:6 perpendicular to the through roadway which are inside the 3R Project Clear Zone (See Section 6.D of this chapter) should be considered for 1:6 side slopes if there is sufficient existing right-of-way or as recommended by **Traffic Engineering** based on the crash history. See Chapter Four: Intersections, Driveways and Channelization, EXHIBITS 4.14 and 4.15, of this manual for grading examples.
- Subgrade Preparation will be included for all new intersection and driveway pavement.

#### 4.B Raised Medians

In general, curb heights adjacent to high-speed roadways (posted speed limit  $\geq 50$  mph) should be no greater than four inches and should slope at no greater than  $45^\circ$  from the gutter to the top of curb. There are instances where a four-inch curb is insufficient to adequately address the existing hydraulic needs of the roadway; in these instances, permission to retain a curb height greater than four inches requires the approval of the **Roadway Design Engineer** (for pavement drainage considerations see the *Drainage Manual* (Ref. 17.8), Chapter One: Drainage, Sections 9 and 10). Six-inch high curbs are allowed for roundabout curb and splitter islands and to within 400 feet of the inscribed roundabout circle (See Chapter Four: Intersections, Driveways and Channelization, Section 1.A.3, of this manual).

Raised medians with six-inch curb on two-lane high-speed roadways ( $V \geq 50$  mph) will be considered for modification or removal. If **Traffic Engineering** determines that the raised curb median should be retained, the median curb height will be reduced to four inches or less. The slope of the curb face will not be altered.

Before the plan-in-hand, the roadway designer should review raised medians on high-speed roadways ( $V \geq 50$  mph) with **Traffic Engineering** to determine if they should remain in place, be modified, or be removed. Median modifications or removals should be noted on the plan-in-hand report.

Where there are raised medians on cross-roads which are proposed to be modified, the medians should be reviewed by **Traffic Engineering**. Raised medians should generally be located outside of the mainline total shoulder width and the intersection should be checked with the appropriate design vehicle turning template (See Chapter Four: Intersections, Driveways and Channelization, EXHIBIT 4.13, of this manual).

### 5. INTERCHANGES AND GRADE SEPARATIONS

Interchange ramps will only be re-constructed to new geometrics if there is a safety issue or if the ramp pavement needs to be replaced as recommended by **M&R**.

The roadway designer should verify the need for bridge work for grade separation bridges. If the grade separation bridge needs are not the primary need for the project, these needs could be spilt out and repairs and rehabilitation completed as a separate project. Once the project process extends beyond the PCM 35 meeting (See Appendix K of this manual), grade separation bridge needs should be completed as part of a separate project.

When a grade separation bridge must be replaced, the approach profiles will not be improved unless crash performance data identifies a sight distance or other problem that needs to be mitigated as part of the improvement. The approach pavement may need to be replaced on the existing alignment on a profile that does not meet the new and reconstruction criteria. This can be performed as a short segment of new and reconstruction (See Chapter One: Roadway Design Standards, Section 10.B, of this manual).

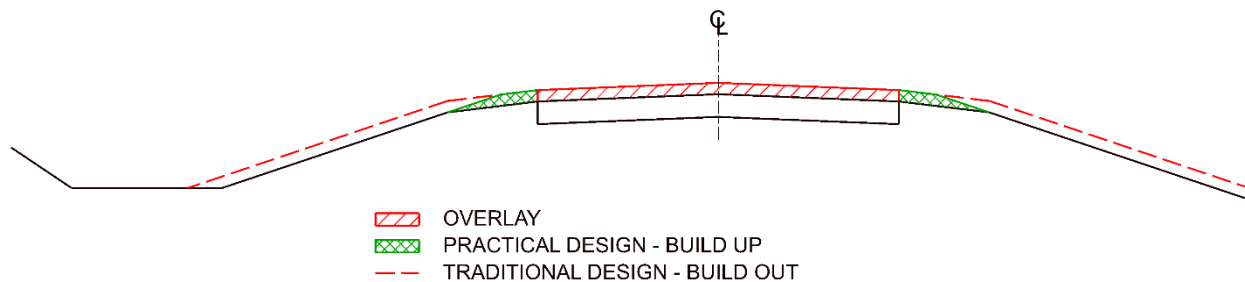
New overhead structures should accommodate a grade raise on the undercrossing roadway (See Chapter Ten: Miscellaneous Design Issues, Section 2.E.1, of this manual).

## 6. THE TYPICAL ROADWAY CROSS-SECTION

### 6.A Initial Roadway Assumption for 3R Projects and Analysis of Alternatives

As a starting point for determining a typical cross-section for a 3R project, assume a desirable highway design typical cross-section. The desirable typical cross-section is the roadway top width as shown in the most recent as-built plan set OR the roadway top width from which the highway was most recently reconstructed. The roadway designer should compare the desirable highway design typical to the 3R minimum design standards lane and shoulder widths (See the *MDS*, Ref. 17.1) and use whichever is greater. This desirable top width can be compared to or tested against other narrower alternatives to decide on the project's typical cross-section. Analysis of cost effectiveness and safety performance is a means of comparing or testing various alternatives to achieve a practicable, cost-effective and timely project (See the introductory commentary "Analyses of Benefits Versus Costs" of this chapter). The shoulder width determined should be shown and labeled on the Typical Cross-Section Sheet(s) for the project (See Chapter Eleven: Highway Plans Assembly, EXHIBIT 11.3, of this manual).

For example, if building back the existing top width provides needed safety performance; it should be the selected alternative. However, a "built up" strategy instead of a "build out" strategy might be the selected alternative (See EXHIBIT 17.5). Applying a narrower shoulder over the existing foreslopes and avoiding "slivers" of embankment, new right of way and environmental permitting, while maintaining the overall safety performance, could be the appropriate alternative for the highway segment.



**Exhibit 17.5 Build Up Strategy vs Build Out Strategy**

## 6.B The Traveled Way

For 3R projects, there is potential for adjusting the cross-slope from the as-built plans on the existing roadway. The roadway designer should evaluate correcting the cross-slope of the roadway as part of the project to bring it into accordance with the Minimum Design Standard for that functional classification of roadway. Typically, this is a correction to 2% cross-slope. If cross-slope correction is needed, additional asphalt quantities may be required for the project.

12-foot lanes are desirable and the minimum width for most highway segments based on the *MDS* (Ref. 17.1). However, a lane width may be constructed (or striped) at less than 12 feet if a cost/benefit analysis shows more benefits than costs. Any reduction in lane width must first be approved by the **Roadway Design Engineer**. A reduction in lane width may result in a need for a design exception and/or a relaxation of the *MDS* (Ref. 17.1) (See Chapter One: Roadway Design Standards, Section 10, of this manual).

Application of a high friction surface course to the mainline roadway or bridge may provide a safety benefit to the project.

## 6.C Shoulders

The composition and dimensions of the shoulders will be part of a review of the as-built plans. Options may exist where the type and width of the shoulders could be modified to avoid additional work outside of the shoulder hinge point. The shoulder width chosen should be shown on the plans and labeled on the Typical Cross-Section Sheet(s) for the project (See Chapter Eleven: Highway Plans Assembly, EXHIBIT 11.3, of this manual).

For example, if there is a proposed four-inch grade raise on a roadway with two 12-foot lanes and eight-foot turf shoulders, the roadway could be designed to two 12-foot lanes, seven-foot shoulders, of which two feet is surfaced, with rumble strips and a beveled edge. Performing a benefit/cost analysis may conclude that this is more cost effective and provides an overall reduction in crashes. As part of this example, the shoulder width labeled on the plans should be shown as seven-foot. The width is less than what was previously constructed but wider than the 3R minimum width defined in the *MDS* (Ref. 17.1).

For shoulders that were previously designated (for example) as 10-foot with eight-foot paved, and where the surfaced width matches or exceeds the *MDS* (Ref. 17.1), the paved width will be identified as the shoulder width. The turf transition between the paved shoulder and the shoulder hinge point will not be labeled as part of the shoulder.

For 3R projects on the Priority Commercial System (See Chapter One: Roadway Design Standards, Section 4.F, of this manual), the minimum shoulder width shall follow the *MDS* (Ref. 17.1).

For guidance regarding the installation of two-foot surface shoulders on lower volume roadways, see Chapter Six: The Typical Roadway Cross-Section, Section 2.A.2, of this manual.



## 6.D The 3R Project Clear Zone

The Roadside Design Guide (Ref. 17.9) defines a Clear Zone as the total roadside border area, starting at the edge of the traveled way, available for safe use by errant vehicles. This area may consist of a shoulder, a recoverable slope (1:4 or flatter), a non-recoverable traversable slope (1:3 or flatter), and/or a clear run-out area.

Horizontal Clear Zone (HCZ) refers to the minimum clear zone requirements established for a segment of highway during a New and Reconstruction project (when the highway was originally built or most recently reconstructed). The HCZ may have also been referred to as the Lateral Obstacle Clearance in previous versions of the *MDS* (Ref. 17.1). One of the defining characteristics of the HCZ in the *MDS* is that side slopes must be 1:6 or flatter. For highway segments constructed or reconstructed prior to 1971 (when **NDOT** began establishing clear zones), there is no defined HCZ.

Fixed Obstacle Clearance (FOC) refers to the minimum clear zone requirements that must be met or maintained on a segment of highway for a 3R project. One of the differences between HCZ and FOC is the allowable side slope within the clear zone. FOC allows side slopes 1:3 or flatter.

The 3R Project Clear Zone is a term used to describe the specific clear zone established as part of a 3R project. It is desirable that all 3R projects perpetuate the existing HCZ. Therefore, the desired 3R Project Clear Zone is the previously established HCZ for that highway segment.

It may not be practicable to perpetuate all elements of the HCZ previously established (or for the entire length of the 3R project) based on site conditions or other constraints. If this cannot be done, the roadway designer may adjust the 3R Project Clear Zone to no less than the applicable FOC from the *MDS* (Ref. 17.1) with **Unit Head** approval.

If there are roadside obstacles inside the HCZ area, but outside the FOC area, the obstacles may be shielded (protected) provided it is cost effective. A benefit/cost analysis (BCA) should be conducted to determine whether it is cost effective to protect the obstacles, remove them, or allow them to remain in place. A BCA ratio of 2:1 is desired when making this decision. In these instances, there is flexibility to allow obstacles to remain in place, down to the minimum applicable FOC width from the *MDS* (Ref. 17.1). A decision document describing the analysis should be completed and placed in the project file.

For Rural Interstate 3R projects, the 3R Project Clear Zone is 35 feet. The 3R Project Clear Zone is 30 feet for Municipal Interstate 3R projects.

If the FOC width from the *MDS* (Ref. 17.1) is not practicable to attain, the procedure for the relaxation of the 3R minimum design standards will be followed (See Chapter One: Design Standards, Section 10.B, of this manual).

In summary, the 3R Project Clear Zone should be noted in design plans as either HCZ or FOC as noted below:

1. The desirable condition is to set the 3R Project Clear Zone equal to the HCZ from the previous New and Reconstruction project, if 1:6 slope and clear of obstacles. It will be shown on the project's Typical Cross-Section Sheets and labeled "Horizontal Clear Zone" (See Chapter Eleven: Highway Plans Assembly, Section 4.B, of this manual); or
2. The FOC width from the *MDS* (Ref. 17.1) is applied to the 3R project if the previous project was constructed or reconstructed prior to 1971, or if applying the HCZ from a previous project is not practicable, as demonstrated by a BCA. This distance should be shown and labeled "Fixed Obstacle Clearance" on the project's Typical Cross-Section Sheets (See Chapter Eleven: Highway Plans Assembly, Section 4.B, of this manual).

Auxiliary Lanes should be evaluated using the selected 3R Project Clear Zone. See Chapter Six: The Typical Roadway Cross-Section, EXHIBIT 6.15, of this manual for additional information.

For more information on obstacles and shielding, see Section 9 of this chapter and Chapter Nine: Guardrail and Roadside Barriers of this manual.

#### **6.E Foreslopes and Other Slopes, Earth Dikes, and Mailbox Turnouts**

If the project includes foreslope grading, small slivers of fill should be avoided. It is desirable to construct slopes that are 1:3 or flatter. The minimum foreslope that should be used within the 3R Clear Zone is 1:3 (See Section 6.D of this chapter). Slopes beyond the 3R Clear Zone may be steeper than 1:3 but the roadway designer should evaluate the project as a whole and consider departure crashes, crash history and trends along the segment. Fill slope treatments beyond the 3R Clear Zone should be applied consistently along the length of the project. This evaluation should consist of a benefit/cost analysis to use the existing slopes in place.

The roadway designer should use a slope no steeper than 1:4 when blending shoulder construction to an existing 1:6 or flatter foreslope. A 1:3 slope should be used to blend the shoulder construction to an existing foreslope which is steeper than 1:6. Except where a slope is shielded, slopes steeper than 1:3 should be avoided unless there is a decision document approved by the **ADE**.

New earth dikes within the 3R Project Clear Zone (See Section 6.D of this chapter), which are perpendicular to the traffic, will have a 1:6 slope on both the onsite (upstream) and offside (downstream) face of the dike. Dikes and maintenance turnarounds in a median will have 1:10 slopes on both faces of the dike. When reconstructing a median dike, the roadway designer will verify that the median pipe and/or inlet still drains.

Driveways and Intersections within the 3R Project Clear Zone with slopes steeper than 1:6, which are perpendicular to the through roadway, may be used in place based on the crash history and recommendations by **Traffic Engineering**, otherwise consider building 1:6 side slopes.

Mailbox turnouts will be built as detailed in Standard Plan 307, "Mailbox Turnout" (See the Standard/Special Plans Book (Standard Plans), Ref. 17.10) (<https://dot.nebraska.gov/business-center/design-consultant/stand-spec-manual/>).

## 6.F Turn Lanes and Auxiliary Lanes

An auxiliary lane may be added to a 3R project without grading to New and Reconstructed standards.

An existing sub-standard right-turn lane on a rural un-signalized high-speed ( $V \geq 50$  mph) roadway (where a surfaced shoulder has been re-striped to provide a turn lane) will be reviewed by **Traffic Engineering** to determine if the turn lane is warranted.

If the right-turn lane is not warranted, removal of the right-turn lane may be considered. The decision to remove should be based on the cost to improve the turn lane to updated geometric standards. If the cost and impacts to right-of-way and the environment is significant, and removal seems like the best option, the roadway designer should consult with **Communications Division** about the appropriate public engagement to help determine the societal impacts of removing the turn lane. The turn lane may be removed only after the public comments have been considered.

If the right-turn lane is warranted, and if there is not a crash problem, geometrics may be improved, and the right-turn lane can remain in place. If warranted, and there is a history of crashes, consider either improving the right turn lane (i.e. increase storage or taper length) or building an offset right-turn lane (see Chapter Four: Intersections, Driveways and Channelization, Section 1.D.3, of this manual).

**Traffic Engineering** may recommend turn lanes and lane configuration changes by re-striping the roadway. The roadway designer should verify that the new configuration does not violate the 3R minimum design standards for shoulder or surfaced shoulder width.

For example, an existing 24-foot wide roadway may only require six-foot wide surfaced shoulders by standards, but the existing section has eight-foot wide surfaced shoulders. When the roadway is re-striped to a 36-foot wide three-lane section, two-foot wide surfaced shoulders result. This arrangement would require either expanding the existing shoulders to obtain the six-foot wide surfaced shoulder or a design exception and/or a relaxation of the *MDS* (Ref. 17.1) could be considered if added shoulders are not needed based on engineering analysis (See Chapter One: Design Standards, Section 10, of this manual).

## 7. EARTHWORK

If the volume of the shoulder construction plus the embankment is less than 500 cu. yds. per mile, pay for “Earth Shoulder Construction” only (See Chapter Eight: Surfacing, Section 4.C, of this manual). If the total exceeds 500 cu. yds. per mile, the pay items would be “Earthwork Measured as Embankment” and “Earthwork Shoulder Construction”.

Any grading under new pavement (e.g. at guardrail, mailbox turnouts, culvert locations) will be paid for as “Earthwork Measured as Embankment”, or “Roadway Grading”, where necessary. See Chapter Seven: Earthwork, Sections 4.B.1 and 4.C of this manual).

The required roadway grading details will be shown on the Typical Cross-Sections or on the General Information (G) Sheets (See Chapter Eleven: Highway Plans Assembly, Sections 4.B and 4.G, of this manual).

If paying for embankment as an established quantity (EQ), a balance factor of 1.0 shall be used and the pay item will be “Earthwork Measured in Embankment (EQ)” (See Chapter Seven: Earthwork, Section 4.B.1, of this manual).

When using “Earthwork Measured in Embankment (EQ)” as the pay item: the embankment quantity will be multiplied by an assumed balance factor of 1.5 when calculating the pay item “Water Applied”.

The roadway designer should provide design data and Earthwork Data (Q) Sheets for projects with adequate surveys (See Chapter Eleven: Highway Plans Assembly, Section 4.Q, of this manual).

Cross-sections, when included, should show grading (e.g. for culverts, guardrail grading).

See Chapter Seven: Earthwork, of this manual, for additional information.

## 8. SURFACING

### 8.A Mainline Surfacing Taper Rate

For an overlay on a high-speed ( $V \geq 50$  mph) roadway, the minimum taper rate at the end of the project is 33 feet to each inch of change in grade (e.g. for a two-inch mill with a four-inch overlay:  $2 \times 33 = 66$  feet). The preferred taper rate is 50 feet to each inch of change in grade (e.g. for a two-inch mill with a four-inch overlay:  $2 \times 50 = 100$  feet).

The taper rate at the end of an overlay on a low-speed ( $V \leq 45$  mph) roadway is 25 feet to each inch change in grade or ending at an intersection if it is within the taper length.

### 8.B Rumble Strips, Edgeline Rumble Stripes, and Centerline Rumble Stripes

Rumble strips, edgeline rumble stripes, and centerline rumble stripes should be perpetuated on projects, considered for inclusion in the scope of work as recommended or advised by the **Traffic Engineering** and/or the **District**, or constructed as needed to meet the requirements of the NDOT Policy on The Predicted Safety Performance of 3R Projects (refer to this chapter's Introduction). Construction of rumble strips on the project may be coordinated with another project in the area to reduce mobilization costs.

For additional requirements, guidance and information on rumble strips, edgeline rumble stripes, and centerline rumble Stripes, see Chapter Eight: Surfacing, Section 7, of this manual.

### 8.C Beveled Edge

See Chapter Six: The Typical Roadway Cross-Section, Section 2.C, of this manual.

### 8.D Surfacing Quantities

Additional quantities for asphalt are required if cross-slope correction is utilized as part of the project. Also, correcting the superelevation requires additional quantities be provided. Additional quantities for superelevation and cross-slope correction are shown separately on the Design Plans.

For additional information see Chapter Eight: Surfacing, Section 5, of this manual.

## 9. GUARDRAIL AND ROADSIDE BARRIERS

Obstacles within the 3R Project Clear Zone should be evaluated to see if they should be removed, shielded, or may be left in place. The 3R Project Clear Zone is defined in Section 6.D of this chapter. Any guardrail or barrier design will be in accordance with Chapter Nine: Guardrail and Roadside Barriers of this manual.

Existing roadside barriers must be reviewed for compliance with the National Cooperative Highway Research Program (NCHRP) Report 350 or the Manual for Assessing Safety Hardware (MASH). If guardrail or hardware work is necessary, the guardrail will be upgraded to the MASH criteria.

The Bridge Buttress will be assessed based on the existing guardrail height connection. If the guardrail is to be upgraded, the roadway designer will identify the need for upgrading buttress remodel. The roadway designer will notify the **Bridge Designer** of the buttress remodel request.

### 9.A Within the 3R Project Clear Zone

Existing guardrail shielding an obstacle within the 3R Project Clear Zone **will not** be removed without mitigating the obstacle it is intended to shield. If the obstacle was previously mitigated, the guardrail may be removed. Any guardrail that is to be removed as part of the project should be discussed at the plan-in-hand and included in the Plan-In-Hand Report. Mitigating the obstacle may include extending a culvert, adding a flared end section, removing a tree, flattening a foreslope, etc.

### 9.B Cost-Effectiveness Analysis

If a cost-effectiveness analysis indicates that an obstacle within the 3R project clear zone may be used in place without shielding, the roadway designer shall include the analysis and backup data in the project file. It is desirable to flatten existing fill slopes steeper than 1:3, however, existing fill slopes that are not shielded, may be used in place per the *MDS* (Ref. 17.1) within the applicable 3R fixed obstacle clearance.

The **Unit Head** or designee should perform a cost effective analysis such as “Roadside Safety Analysis Program” (RSAP) or similar to determine the desirability of the following:

- Removing existing guardrail if the obstacle is removed or modified
- Installing a barrier to shield obstacles within the 3R Project Clear Zone.
- Installing a barrier to shield concrete box culverts and for culvert pipes with a diameter greater than 36 inches which are located within the 3R Project Clear Zone
- Delineating an obstacle which is not practicable to remove or shield

Existing guardrail, which a cost-effectiveness analysis indicates is not required, **may not** be removed without the written approval of the **Roadway Design Engineer** as evidenced by a Design Decision Document filed in the project folder.

### 9.C Roadside Barriers and End Treatments

When it is not possible to install sufficient roadside barrier length to shield the 3R Project Clear Zone as appropriate (e.g. a railroad access drive which cannot be relocated and is within the design length of the guardrail), the roadway designer will obtain the concurrence of the **Unit Head** and document the reason in the project file.

For guardrail design, the roadway designer should use the tables and typical layout guidance found in Chapter Nine: Guardrail and Roadside Barriers, EXHIBIT 9.3, of this manual for runout length ( $L_r$ ) values. The roadway designer may interpolate  $L_r$  values for speeds not listed in the tables. There are several common guardrail design scenarios on 3R projects that may occur.

- A Guardrail End Treatment Type I (See Chapter Nine: Guardrail and Roadside Barriers, Section 4.A, of this manual) may be installed to minimize earthwork and to avoid buying right-of-way on projects where right-of-way is not being purchased for other features of the project.
- The area behind the roadside barrier (either new installation or existing) will be evaluated for the required barrier deflection (See **Table 5-6** of the Roadside Design Guide, Ref. 17.9) and cleared or re-designed as necessary.
- A short radius guardrail may be used in select situations with **Unit Head** approval (See Chapter Nine: Guardrail and Roadside Barriers, Section 7.A, of this manual).
- Cable guardrail may be installed at the locations that warrant a roadside barrier when the additional barrier deflection is allowed, including culvert locations when there are concerns with snow and drifting.

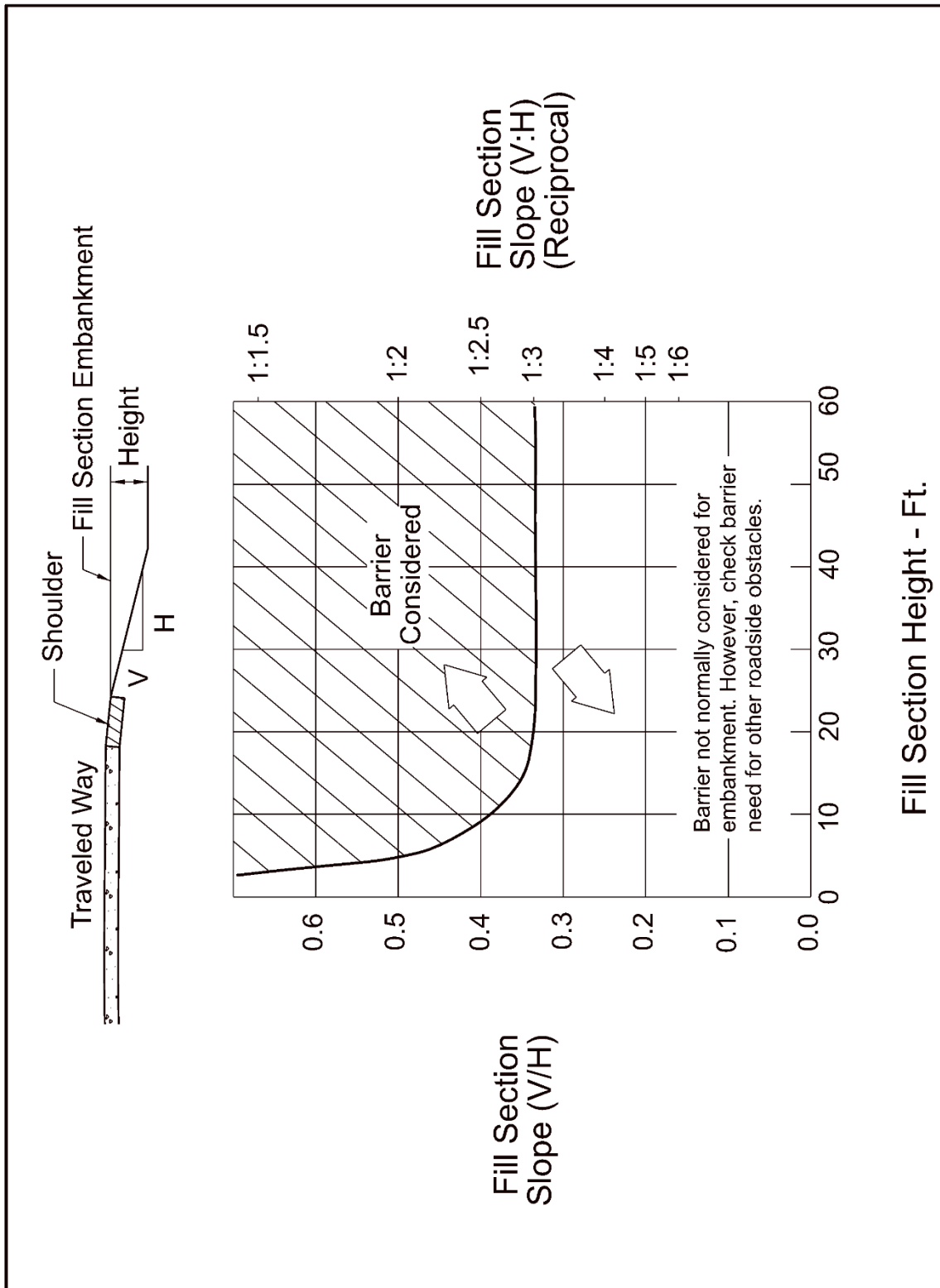


Exhibit 17.6 Comparative Barrier Consideration for Embankments  
 Source: Roadside Design Guide (Ref. 17.9)



## 10. MISCELLANEOUS DESIGN ISSUES

### 10.A Railroads

Work on railroad right-of-way must conform to Title 415, Nebraska Administrative Code, Chapter 6 (Highway-Rail Crossings – Construction, Repair and Maintenance) and requires a special provision prepared by the **Rail Unit** in the **Local Assistance Division**. Chapter 6 may be found at ([Chapter-6.pdf \(nebraska.gov\)](#)).

The roadway designer should e-mail the **Highway Liaison Manager** in the **Rail Unit** in the **Local Assistance Division** with the Project C.N., Project No., Designer, and Designer's Phone Number for the initiation of the "Railroad Project Information Sheet" (NDOT-95) after the plan-in-hand.

For the **Plans, Specifications and Estimates (PS&E)** turn-in, the roadway designer should compute separate quantities for the work which is on railroad right-of-way (See Chapter Twelve: Cost Estimating & Funding, Section 1.E, of this manual).

The condition of a railroad crossing, the width of the crossing, and the distance to the center and nearest point of the signals should be noted on the plan-in-hand.

### 10.B Bridges

Bridges on 3R projects will generally be used in place with some measure of preservation applied to the structure. Generally, these activities will consist of needed repairs to the structure and surrounding area to preserve the asset (See Chapter One: Roadway Design Standards, Sections 6.B.1 and 6.C.2.a, of this manual).

The roadway designer should review the bridge determination during Roadway Design (Clarity Task 5350) and determine if additional roadway work is required to accommodate the bridge determination. For example, if there are erosion issues at the abutment, flumes or inlets may be needed at the end of the bridge deck to mitigate this erosion. Additional inlets or flumes may be needed at the bridge corners if the bridge determination includes three-inch or four-inch "Curb Angles".

There may be a need for bridge repairs that necessitate traffic maintenance and phasing of construction activities. This may require the use of temporary signals, barriers, or stream access crossings to accommodate construction.

Guardrail connections and bridge rail on the project will be evaluated and, if necessary, upgraded to current criteria (e.g. guardrail meeting NCHRP 350 is in place). The roadway designer should request a determination of the acceptability of the bridge rail by **Bridge** prior to the plan-in-hand field inspection (see Section 9.C of this chapter for additional information).

The roadway designer will make adjustments to the approach roadway cross-section as needed to match the bridge cross-slope. Tapering of the roadway cross-slope may be needed to match the bridge floor elevation.

See Sections 1.G & 17.B of this chapter and Chapter Ten: Miscellaneous Design Issues: Section 2, of this manual for additional information.

### **10.C Temporary Roads**

Either phased construction, detour, shoofly or temporary roads may be used to accommodate traffic during construction. See Chapter Fourteen: Traffic, Section 6, of this manual for details.

### **10.D Lighting**

Before the plan-in-hand, the roadway designer should request a review of state highway junctions for lighting warrants from the **Roadway Design ITS/Lighting Unit (ITS/Lighting)**. See Chapter Ten: Miscellaneous Design Issues, Section 13, of this manual for additional information.

### **10.E Agreements/Cost Sharing**

#### **10.E.1 Agreements**

Projects located within the corporate limits of a municipality, **Sanitary Improvement District (SID)**, or in rural areas that demonstrate urban traffic characteristics should be reviewed before the plan-in-hand for ADA work, lighting, and applicable cost sharing. **City/Village/SID** representatives should be invited to the plan-in-hand and be informed of the estimated cost (See DOT-OI 60-11, "Municipal Cost Sharing", Appendix B, "Selected NDOT Operating Instructions", of this manual).

An agreement is required at the request of the **DE** or if any of the following items are associated with the project. Those may include:

1. Financial participation, including city betterments (See DOT-OI 60-11, "Municipal Cost Sharing", Appendix B, "Selected NDOT Operating Instructions") of this manual).
2. Rehabilitation of **Municipality**-owned utilities.
3. **City** work off the highway system that may require coordination.
4. Elimination of encroachments on **State** right-of-way.
5. Assignment of duties/responsibilities for maintenance or operation of facilities
  - a. Storm sewer and culverts
  - b. MS4 Stormwater Treatment Facilities (STFs)
  - c. Traffic signals
  - d. Lighting structures and power
  - e. No parking zone ordinances
6. Relocation or change in function of municipal or county roadways.
7. Detour utilizing local street or county roads.

### 10.E.2 Letter of Notification

If the conditions above that require an agreement are not met, then a Letter of Notification may be used to provide the **Municipality** an opportunity to comment on the project. A Letter of Notification may also be used when constructing ADA ramps and transitions. The letter should include a statement commenting that the **City** or **County** is responsible for the maintenance of the ADA ramps, transitions, and sidewalk that are constructed as part of the project. As part of the letter, the location of the ramps that are part of the project should be included.

The Letter of Notification should include an option for the **City** or **County** to respond with comments or concerns. If they have concerns, then **NDOT** should consider entering into an agreement with the **City** or **County** establishing responsibility of local for operations, maintenance and repairs for the sidewalk or ADA Ramps.

### 10.F Utilities

Utility coordination for 3R projects is handled similarly to utility coordination on New and Reconstruction projects. The roadway designer should reference Chapter Ten: Miscellaneous Design Issues, Section 12, of this manual for detailed information regarding utility coordination on both project types. This section will highlight areas key to the delivery of 3R projects.

The roadway designer should review the project with the **Utility Coordinator** in **Roadway** before the plan-in-hand to discuss the project scope in order to determine any possible utility impacts, as well as after the plan-in-hand to determine if additional survey for utilities is required.

The **Utility Coordinator** and **Utility Engineer** should be invited to Project Coordination Meetings 30, 35, and 50 for identifying and determining impacts to utilities within the project limits.

#### 10.F.1 Preliminary Utility Inspection Report

To verify the location and type of existing utilities on the project site, the **Utility Coordinator** conducts a review of the project utilizing the Nebraska One-Call website, NDOT ARMS permit database, and may conduct a field visit to verify the information. An additional utility survey may need to be ordered to address additional utilities identified by the **Utility Coordinator** which are not in the **NDOT** survey.

A review of existing **NDOT** owned utilities also needs to be conducted on every project. The roadway designer will need to coordinate with the **Utility Coordinator** on this review. **NDOT** owned utilities are managed by **Traffic Engineering**, **ITS**, **Lighting**, and **Strategic Planning**. Below is a non-exclusive list of **NDOT** owned utilities for each division.

**Traffic Engineering**: traffic control devices, traffic signals and signs, etc.

**Roadway Design ITS**: Intelligent Transportation Systems (ITS): cameras, towers, Dynamic Message Signs (DMS) boards, pavement sensors, etc.

**Roadway Design Lighting**: light poles, pull boxes, lighting control centers, etc.

**Strategic Planning**: automated traffic counters, weigh in motion sensors, etc.

Each device is likely to have the associated underground fiber optic and electrical lines that may be in conflict and need to be mitigated.

The **Utility Coordinator** will incorporate any existing **NDOT** owned utilities into the Preliminary Utility Inspection Report. The report will also address where the existing facility is located, if it will conflict with the project, how that conflict is anticipated to be resolved, and who is responsible for resolving the conflict. Construction plans and Special Provisions may be required if a **NDOT** owned utility is in conflict. A summary of existing and proposed **NDOT** owned utilities shall be captured in the PIH report.

The **Utility** Coordinator will complete the Preliminary Utility Inspection Report on OnBase and provide a copy to the roadway designer. The Preliminary Utility Inspection Report identifies the type of and owner of each facility on the project, where the existing location is expected to be, if the facility is anticipated to be in conflict, and if the required utility relocation work will be conducted by the utility company or **NDOT's** contractor. A preliminary utility cost estimate is also provided on the Preliminary Utility Inspection Report.

### 10.F.2 Utility Potholing

The roadway designer may encounter underground utilities that are impacted by the design and should review the project with the **Utility Coordinator** to determine if potholing is necessary. Potholing is a localized excavation method for obtaining visual confirmation of the location of existing utilities. The roadway designer can develop a design to avoid some utility impacts once the location of existing utility facilities is confirmed. It is more likely that potholing will be required in Urban areas as underground utilities are more prevalent and a greater disruption if impacted.

### 10.F.3 Plan-in-Hand Report

A Utility Summary shall be included in the plan-in-hand report. The Utility Summary shall be comprised of a list of the utility companies in the project area, any anticipated conflicts affecting those utilities, and any utility facility that should be avoided, if possible. Existing and proposed **NDOT** owned utilities shall also be addressed in the plan-in-hand report.

The information to be included in the plan-in-hand shall consist of who has facilities within the project area, where those facilities are located, if any existing facilities are in conflict with the project, how the utility conflict will be mitigated, and who is responsible for relocating the utility in conflict, whether it is the utility company or the **NDOT** Contractor.

The Preliminary Utility Inspection Report can be used to assist the roadway designer in developing this summary. However, additional coordination may be required with the **Utility Coordinator** if a significant amount of time has passed since the Preliminary Utility Inspection Report was created.

### 10.F.4 Utility Status 45 Estimate

The initial utility estimate is developed by **PDD** at 2.9% of the construction cost. The utility cost estimate needs to be updated at the time of the Status 45 estimate due to the varied nature of utility impacts on each project. The roadway designer needs to coordinate with the **Utility Coordinator** to develop an updated cost estimate that pertains to the actual utility relocation work on the project. For additional information, see Chapter Twelve: Cost Estimating & Funding of this manual.

#### 10.F.5 Status of Utilities

This is required for the **PS&E** submittal. It will be requested by the **Contracts Unit** in **Construction** and provided by the **Utility Coordinator**. The roadway designer is not responsible for submitting Status of Utilities to **PS&E**.

### 11. HIGHWAY PLANS ASSEMBLY

3R projects are most often shown as plan view over plan view (piggyback) sheets. A resurfacing project may be drawn on Plan and Profile (L) Sheets (See Chapter Eleven: Highway Plans Assembly, Section 4.L, of this manual). If there are special ditches on the project; the use of plan and profile sheets for resurfacing projects can be avoided by placing a special ditch chart on the General Information (G) Sheet (See Chapter Eleven: Highway Plans Assembly, Section 4.G, of this manual). Functional Design Plans (Phase 4) are generally not produced for 3R Projects.

### 12. COST ESTIMATING & FUNDING

Each 3R project should have an accurate itemized estimate developed in **Roadway**. 3R project development is typically shorter than for New and Reconstruction projects, therefore, cost estimates need to be updated frequently. This keeps the unit prices current and the project budget accurate for planning. Specifically, status 30 and 45 estimates are key in project programming and planning. Status 40 estimates are not typically produced for 3R Projects. See Chapter 12: Cost Estimating & Funding, of this manual for a detailed description of estimate preparation. When other governmental agencies are sharing the cost of the improvements, these costs should be split out in the estimate (See chapter 12, Chapter Twelve: Cost Estimating & Funding, Section 2.F, of this manual).

### 13. PROJECT DEVELOPMENT

Environmental impacts should be weighed as part of the evaluation of the project scope, schedule and cost. Impacts to resources could have a detrimental impact to the timely delivery of the improvement.

#### 13.A Wetland Impacts and Environmental Permits

The Planning Document will provide sufficient information to the **404/Wetlands Biologist** of the **Technical Resources Unit (TRU)** in **PDD** to determine if wetland delineation is required, if additional delineations are required the roadway designer will coordinate with the **404/Wetlands Biologist**. Mitigation strategy should be discussed prior to the plan in hand inspection with the **404/Wetlands Biologist**. If the **404/Wetlands Biologist** has determined that no acceptable mitigation bank site is located in proximity to the project, on-site mitigation may be required. See Chapter Thirteen: Planning and Project Development, Section 5.B, of this manual for further information.

#### 13.B Environmental Classification

Federally funded 3R projects generally fall into a Class II for Environmental Classification. Class II is a Categorical Exclusion (CE). The CE will have varying degrees of documentation required based on the impacts associated with the scope of work. Evaluation will occur for sensitive areas (Section 4(f), Section 6(f), Hazardous Materials, etc.) that are located within the project's environmental study area. If impacted by the project, such as acquiring temporary easements or modified access to a 4(f) property, additional coordination or mitigation may be required from the regulatory agencies. For additional information see Chapter Thirteen: Planning and Project Development, Section 5.A.1, of this manual.

#### 13.C Floodplains

Projects with floodplain encroachments are certified by **Roadway** and **Bridge Hydraulics Sections** (See Section 17.D of this chapter) and are submitted to the **Highway Environmental Biologist** for submittal of the floodplain permit to the community. Certifications are uploaded to Onbase by **Roadway** and **Bridge Hydraulics**.

Floodplain permit applications are uploaded by the **Highway Environmental Biologist** to Onbase, as well as the approved floodplain permit.

## 14. TRAFFIC

**Traffic Engineering** will conduct a safety review for each 3R project and recommend mitigation measures based on the crash history. The roadway designer will review the mitigation measures for consistency with the scope of the project and for possible inclusion in the project. Recommendations that exceed the scope of the proposed project may be forwarded to the **NDOT Safety Committee** for a recommendation to program a safety project.

For example, the roadway designer shall request a crash data analysis from the **Highway Safety Manager** in **Traffic Engineering** for a curve identified as having crash issues. If the crash analysis indicates that the traveling public may benefit from improving the curve, the dollar amount of the benefit (the value of the expected change in the number and type of crashes) will be requested from the **Traffic Engineering Highway Safety, Evaluation, and Analysis Unit**.

If indicated by the crash history and if recommended by **Traffic Engineering**, the roadway designer shall evaluate the acceleration and deceleration lengths of interchange, rest area, and weigh station ramps to see if they are compatible with the design speed (See Chapter 10 of the *Green Book*, Ref. 17.5), and will coordinate with **Traffic Engineering** as required.

Changes to the existing roadway configuration may require a level of public input commensurate with the significance of the change. For example, the removal of striped right turn lanes, would require public input. The roadway designer shall coordinate with the **Communication Division** when the scope of the project is known, to determine the necessary level of public involvement including Public Information Meetings, flyers, or press releases. Other significant roadway changes that may necessitate public involvement include adding right turn lanes, adding two-way left turn lanes, road diets, complete streets, or other geometric changes that may impact the public.

## 15. RIGHT-OF-WAY

It is preferable to avoid right-of-way acquisition on 3R projects; however, additional right-of-way may be needed for the completion of the project. Acquisition of additional property rights may result in controversy and delay to the project due the acquisition process or the public involvement process.

Appropriate details and reasons for acquiring right-of-way should be communicated to the **ROW Design Engineer** during Roadway Design (Clarity Task 5350). The need for additional right-of-way may stem from intersection improvements, culvert extensions, guardrail grading, or any other design feature.

When projects, which do not have right-of-way acquisition scheduled, may require additional property rights, this should be communicated to the **ROW Design Engineer** and the **Project Scheduling and Program Management Division** as soon as these areas are known so that **ROW** may begin right-of-way survey. See Chapter Fifteen: Right-of-Way, of this manual for additional information.

## 16. PEDESTRIAN AND BICYCLE FACILITIES

NDOT has adopted the guidance in the [Accessibility Guidelines for Pedestrian Facilities in the Public Right-of-Way \(2023\)](https://www.federalregister.gov/documents/2023/08/08/2023-16149/accessibility-guidelines-for-pedestrian-facilities-in-the-public-right-of-way) (*Accessibility Guidelines*) (Ref. 17.11), issued by the **Architectural and Transportation Barriers Compliance Board** (<https://www.federalregister.gov/documents/2023/08/08/2023-16149/accessibility-guidelines-for-pedestrian-facilities-in-the-public-right-of-way>). Facilities for those with disabilities may meet local requirements if those requirements meet or exceed **NDOT** policy.

For 3R projects in **Omaha, Lincoln** and other first-class cities, the roadway designer should meet with the **City** and discuss pedestrian and bicycle facilities. This meeting could occur prior to or as part of the PIH inspection. The 3R project scope should support the communities plans for multimodal facilities. The 3R project should build pedestrian and bicycle facilities if there is sufficient right of way to accommodate the facilities, Sidewalks should be connected to the sidewalks that are discontinuous and adjacent to the highway right-of-way. The cost of the pedestrian and bicycle facilities should be paid for as part of the municipal cost share for the project (See the Nebraska Dept. of Transportation Operating Instruction 60-11, “Municipal Cost Sharing” in Appendix B, “Selected NDOT Operating Instructions”, in this manual). The municipal cost share should begin just beyond the curb ramps and pedestrian facilities adjacent to the highway intersections. Pedestrian and bicycle facilities over bridges may not be practicable and should be discussed with the **ADE** for recommendations on how to proceed.

For 3R projects in all other **Cities**, the designer should consider the need for pedestrian and bicycle facilities. The designer should consider the types of business, parks or schools, worn paths, and existing facilities that are not continuous or not connected and discuss the need for facilities along the highway with the **DE**. If it is determined that there is a need for improved pedestrian and bicycle facilities, they will be constructed as part of the project scope. These facilities will desirably be constructed on the highway right of way. For cities with a population less than 5,000, pedestrian and bicycle facilities will be constructed as a project cost.

For additional information, see Chapter Sixteen: [Pedestrian and Bicycle Facilities](#), Chapter Ten: [Miscellaneous Design Issues](#), Section 14.A, “Accessible Parking”, and DOT-OI 60-10, “ADA Accessibility Requirements in Transportation Projects” (Appendix B, “Selected NDOT Operating Instructions”), in this manual.



## 17. DRAINAGE DESIGN AND EROSION CONTROL

### 17.A Culverts and Hydraulic Considerations

3R projects generally do not require a hydraulic analysis of culverts unless there is a known drainage or hydraulic problem, or culvert replacement. Known drainage or hydraulic problems can include highway overtopping, channel degradation, scour, deteriorating culverts, embankment settlement, etc. Culvert survey and survey sheets should be checked for culvert conditions. Show all culverts on all 3R projects where we have a culvert survey (Use in Place) where needed. Culverts in poor condition should be considered for replacement. When a culvert is to be replaced, a hydrologic and hydraulic analysis is completed to determine the size of the replacement structure. Drainage and culvert replacements should be discussed with **District** personnel.

The roadway designer should be consistent with culvert extensions, looking at the project as a whole. In general, culverts that are extended will be extended to the 3R FOC. Culverts may be extended to the New and Reconstructed HCZ distance with the written approval of the **Roadway Design Engineer**. Culvert extensions should be reviewed when culvert extensions require extensive grading or special ditches. Drainage of culverts and ditches should be perpetuated to maintain existing flow patterns.

Pipe replacements should consider the risk of corrosion in the selection of pipe material. The roadway designer should refer to the pipe material policy for the selection of pipe material. In addition, the NRCS Web Soil Survey (<https://websoilsurvey.nrcs.usda.gov/>) can be used to assist in the determination of the "risk of corrosion" of the pipe replacement. The risk of corrosion is expressed as "low", "moderate", or "high".

When extending a culvert in a location where additional property rights are being acquired, the roadway designer should review the right-of-way design and try to provide at least 10 feet of cleanout space beyond the ends of the culvert.

For additional information, see Section 1.H of this chapter.

### 17.B Concrete Box Culverts

There are instances where limitations to impacts in channels/wetlands or absence of time in the schedule to acquire property rights prohibits extending concrete box culverts. In these instances, it may be possible to extend the parapet and wings vertically to account for a raise in grade. The ability to increase the height of the parapet and wings is structure dependent and requires the approval of the **Bridge Special Projects Unit** prior to the plan-in-hand visit. Contact the **Bridge Special Projects Engineer** prior to the plan-in-hand visit to discuss the needs of the project. Written concurrence from the **Bridge Special Projects Engineer** is necessary to raise the parapets and walls on each culvert or bridge sized box culvert. In the event none of these options are feasible, an acceptable solution may be to remove the wings and a portion of the box and extend back the same distance with a taller parapet and wings designed to handle the increased soil pressures.

Concrete box culverts with a span of three feet or less may be extended with culvert pipes (the roadway designer will request special plans from the **Special Projects Unit in Bridge**). When box culverts are extended, the preferred method is to remove the wings and two feet of the culvert

barrel before extending the culvert. As an option (e.g. for phasing), the wings of the box culverts may be removed to the parapet line and the extension doweled into the existing box (a special plan will be required from the **Special Projects Unit in Bridge**). Discuss the preferred method with **District** on the Plan-in-Hand.

If there is a drop in the stream bed elevation, concrete box culverts can be modified to a larger rise to accommodate the drop in elevation before extending.

### **17.C Pipe Culverts**

Culverts may remain within the 3R Project Clear Zone if they are:

- 36 inches or less in diameter or round-equivalent culverts 36 inches or less in width which have flared end sections,
- are within 45° of perpendicular to the direction of travel, and
- meet 1:3 or flatter side slopes.

For Interstate Projects, culverts large enough to be considered an obstacle and either within the 3R Project Clear Zone, or currently protected with guardrail, should be analyzed for extension to the 3R Project Clear Zone.

For replacement of median drains on the Interstate, the designer should select a type of pipe (pipe material) that is consistent for the Interstate segment.

#### **17.C.1 Headwall Removal**

Headwalls on pipes 36 inches or less, and multi-pipe installations 30 inches or less within the 3R Project Clear Zone (See Section 6.E of this chapter) should be removed and replaced with flared end sections (refer to Chapter Nine: Guardrail and Roadside Barriers, EXHIBIT 9.1, of this manual).

Where an existing concrete headwall is in place, the concrete will be completely removed.

#### **17.C.2 Pipe Extension**

If pipe extensions are needed, culvert pipes should be extended in kind. A pipe culvert extension may be skewed up to 3° without an elbow.

Corrugated metal pipes should be extended in two-foot increments. When a metal culvert pipe is extended that does not have an existing end treatment or which is on a skew, a minimum of two feet should be removed from the end of the culvert before extending. If a corrugated metal pipe is extended, the pipes will be connected with an approved water-tight connecting band. If a corrugated metal pipe is shortened and then extended, a concrete collar will be used. When metal arch pipes are extended, concrete collars will be used instead of a connecting band.

Concrete pipes should be extended in four-foot increments utilizing a concrete collar to connect to the existing pipe.

## 17.D Floodplains

An **NDOT** review is required on projects to determine whether a project encroaches upon a Base Floodplain. Projects that encroach upon a Base Floodplain or Regulatory Floodway must meet the following:

1. Base Floodplains – No increase greater than one foot of rise in the Base Flood Elevation, based on the 1% annual chance event (100-year event); and,
2. No increase in potential for property loss or hazard to life; and
3. Regulatory Floodways – No rise in the Base Flood Elevation within a Regulatory Floodway, based on the 1% annual chance event (100-year event).

If the above criteria cannot be met, a project may require an adjustment to the plans to meet the requirements or undergo a Conditional Letter of Map Revision (CLOMR)/Letter of Map Revision (LOMR) process. The **Roadway Hydraulics** and/or **Bridge Hydraulics Section(s)** will provide more guidance if/when this occurs.

The roadway designer's responsibilities for floodplain reviews is to upload and maintain the appropriate project information to Onbase, including the Project Description, Location Map, and Design plans showing the limits of construction. The responsibility for completing the floodplain certification, including the certification of compliance with floodplain regulations, rests with:

- a. The **Bridge Hydraulics Section** for bridge-sized structures, which are structures having an opening measured along the center of the roadway of more than 20 feet (multiple culverts, bridge or box culvert), or
- b. The **Roadway Hydraulics Section** for other structures (bridge, box culvert or multiple pipe culverts with less than a 20-foot span, encroachments into a floodplain by the highway embankment, and other obstructions).

The designer will also add the appropriate floodplain wording to the PIH Report if/as required (See Appendix L "PIH Report & PQS Memo Floodplain Wording", of this manual).

Floodplain terminology which may be encountered by the roadway designer include:

- Participating Community – a **County, City, or Village** in the **State of Nebraska** which participates in the National Flood Insurance Program (NFIP). Project work that will encroach upon a Base Floodplain within the jurisdiction of a participating community requires a permit from that community before it can start. A list of participating communities can be found in the Community Status Book on the **Federal Emergency Management Agency (FEMA)** website (<https://www.fema.gov/flood-insurance/work-with-nfip/community-status-book>).
- Non-Participating Community - a **County, City, or Village** in the **State of Nebraska** which does not participate in the NFIP. Project work that will encroach upon a Base Floodplain within the jurisdiction of a non-participating community does not require a permit from the community.
- Mapped Community – A **County, City, or Village** which has **FEMA** approved and published floodplain mapping that covers the community's jurisdiction. Some maps have been approved and published but not printed due to a lack of any Base Floodplains within the extents of the map. Communities located within these areas will usually be identified

as a NSFHA (No Special Flood Hazard Area) community. Base Floodplains and Regulatory Floodways encroached upon by a project within a Mapped Community require a certification showing compliance with floodplain regulations.

- Unmapped Community - A **County, City, or Village** which does not have **FEMA** approved and published floodplain mapping. In such communities, **NDOT** policy is to define drainage's having a watershed in excess of 640 acres (one square mile) upstream of where project work occurs as potential Base Floodplains. **NDOT** policy is also to define potential Base Floodplains as areas that the **Nebraska Department of Natural Resources (NeDNR)** has identified on its website as Flood Awareness Areas or as a Preliminary Flood Hazard Layer. Potential Base Floodplains encroached upon by a project within an Unmapped Community require a certification showing compliance with floodplain regulations.

For more information regarding floodplain encroachments, see Chapter 1 in the *Drainage Manual* (Ref. 17.8).

#### **17.E      Seeding & Erosion Control**

Type B seeding for an overlay project should be based on the width of the estimated disturbance. Generally, seeding equipment works in eight-foot increments so an overlay project may only require an eight-foot width of Type B seeding (See Chapter Two: Erosion and Sediment Control, Section 6.A.1 of the *Drainage Manual*, Ref. 17.8, for further information). Type A seeding may be used in areas as coordinated with the **Roadside Development and Compliance Unit** in **PDD**.

## 18. REFERENCES

- 17.1 Board of Public Roads Classifications and Standards, Nebraska Minimum Design Standards (MDS), Current Edition.  
(<https://dot.nebraska.gov/media/1z1n5kmb/nac-428-rules-regs-nbcs.pdf>)
- 17.2 Transportation Research Board, National Cooperative Highway Research Program, Guidelines for Integrating Safety and Cost-Effectiveness into Resurfacing, Restoration, and Rehabilitation (3R) Projects, (NCHRP Report 876) ISBN 978-0-309-48225-7, Washington D.C., 2018 (<https://nap.nationalacademies.org/catalog/25206/guidelines-for-integrating-safety-and-cost-effectiveness-into-resurfacing-restoration-and-rehabilitation-3r-projects>)
- 17.3 Federal Highway Administration, Bridge Preservation Guide, U.S. Department of Transportation, FHWA, Washington, D.C., 2018.  
(<https://www.fhwa.dot.gov/bridge/preservation/guide/guide.pdf>)
- 17.4 American Association of State Highway and Transportation Officials, A Policy on Design Standards - Interstate System, (*I-State GB*) Washington, D.C., 2016.
- 17.5 American Association of State Highway and Transportation Officials, A Policy on Geometric Design of Highways and Streets (the *Green Book*), Washington, D.C., 2018.
- 17.6 Transportation Research Board, National Research Council, Highway Capacity Manual, Sixth Edition, Washington, D.C., 2017.
- 17.7 Nebraska Department of Transportation, Design Process Outline (DPO), Current Edition  
(<https://dot.nebraska.gov/business-center/design-consultant/>)
- 17.8 Nebraska Department of Transportation, Drainage Design and Erosion Control Manual (Drainage Manual), Current Edition  
(<https://dot.nebraska.gov/business-center/design-consultant/rd-manuals/>)
- 17.9 American Association of State Highway and Transportation Officials, Roadside Design Guide, Washington, D.C., 2011.
- 17.10 Nebraska Department of Transportation, Standard/Special Plans Book, (*Standard Plans*) Current Edition. (<https://dot.nebraska.gov/business-center/design-consultant/stand-spec-manual/>)
- 17.11 Architectural and Transportation Compliance Board, Accessibility Guidelines for Pedestrian Facilities in the Public Right-of-Way (Accessibility Guidelines), Washington, D.C., August 8, 2023. (<https://www.federalregister.gov/documents/2023/08/08/2023-16149/accessibility-guidelines-for-pedestrian-facilities-in-the-public-right-of-way>)



Nebraska Department of Transportation  
Operating Instruction 60-4  
January 16, 2018

## PROJECT NUMBERING

1. **Purpose:** To provide policy for numbering highway construction projects. The office of primary responsibility is the Program Management Division. This DOT-OI supersedes DOT-OI 60-4 dated January 10, 2018.
2. All project numbers consist of three major parts:
  - A. In part one, the **Prefix** indicates the appropriation type or the highway system. See attachment #1.
  - B. The second part is the **Route Number/Zone** field, consisting of not more than four characters. For projects on the state highway system, the first three characters are the state highway **route number**. The final character is the **zone** of the route in which the project begins. Zones are established for the state from west to east and from south to north. Each state highway is assigned a direction for zoning purposes. Zones for the interstate system differ from those on the rest of the highway system. See attachments #3 and #4. Projects off the highway system, but on a federal-aid route, use the four-character federal-aid route number as the second part of the project number. For projects off the state highway system, all four characters are in a single entity and have no relationship to highway route numbers or zones. They instead reference the county or indicate that the project is statewide.
  - C. Part three is the **Unit** number consisting of not more than four characters. Numbering is sequential within each zone by highway route number. Projects not on the highway system and federal-aid interstate projects begin their sequential series with number 1. Other federal-aid projects on the highway system begin their series with number 101. Highway system projects not using federal funds (including interstate) begin their series with 1001. Projects that contain four characters in part three of their project number **do not** involve federal funds.

When inputting project numbers into the PPM computer system, an eight-character standard is used, consisting of the 4-character Route/Zone field and the 4-character Unit field. Prefixes, dashes and parenthesis are omitted and preceding zeros are used as placeholders, e.g.: NH-80-4(110) is coded as 08040110.

Operating Instruction 60-4

Prefix	Route Number	Zone	Unit	Written On Plans and Other Documents	Input into PPM
STP	84	6	106	STP-84-6(106)	08460106
BRO	7084		5	BRO-7084(5)	70840005
HSIP	STWD*		30	HSIP-STWD(30)	STWD0030

\*Note that the STWD references the location of the project (statewide) and is not part of the prefix.

3. The general types of project numbers include:

- A. Projects on the state highway system are numbered using the highway number, zone and sequential number (in parenthesis), e.g.: NH-2-3(112). Projects on links and spurs use the state spur/link number and a sequential number, e.g.: STP-S55G(102).
- B. Urban system projects in cities of 5,000 or more population use the urban system (5000-6000 series) and the sequential number, e.g.: URB-5044(3).
- C. Federal-aid secondary system projects off the state highway system (major and minor collectors) use the system number and a sequential number, e.g.: RUR-2755(4). Major collectors are numbered from 2000-3000, and minor collectors have a 7000 series number.
- D. Projects not on a federal-aid system use the county number and a sequential number, e.g.: TAP-55(110). Off-system county bridge projects use the county number preceded by "70" and a sequential number, e.g.: BRO-7055(125).
- E. There are other miscellaneous projects, particularly those with federal-aid special funding, which use project numbers not included in these general guidelines. These numbers are assigned by FHWA and have no correlation to our numbering system.

Attachments:

- #1 - Project Prefix Letters
- #2 - Highway Numbers by Direction
- #3 - Non-Interstate Zone Map
- #4 - Interstate Zones
- #5 - Interstate Zone Map

Khalil Jaber, P.E.  
Deputy Director-Engineering



**Project Prefixes**

**Federal-Aid Project Prefixes**

Prefix	Description	Federal Participation Rate
<i>Federal Program Categories</i>		
NH	<i>National Highway Performance Program:</i> Resurfacing, rehabilitation or reconstruction of highways designated as part of the National Highway System, including the Interstate.	80% (90% on the interstate if not used to add capacity)
BR/ BH	<i>Federal-Aid Bridge – On System:</i> Replacement (BR) or rehabilitation (BH) of bridges on the federal-aid highway system.	80%
BRO/ BHO	<i>Federal-Aid Bridge – Off System:</i> Replacement (BRO) or rehabilitation (BHO) of bridges not on the federal-aid system.	80%
STP	<i>Surface Transportation Program - Any Area:</i> Construction, reconstruction, rehabilitation, resurfacing, restoration of federal-aid highways. These funds are generally used on non-NHS highways.	80% (90% on the interstate if not used to add capacity)
LCLC/ MAPA	<i>Surface Transportation Program – Urban Attributable:</i> STP funds set aside for use in Nebraska’s two metropolitan areas with a population over 200,000, Lincoln (LCLC) and Omaha (MAPA). These funds can be used for any of the purposes outlined Under STP funds above.	80%
URB	<i>Surface Transportation Program – Urban:</i> STP funds set aside for use in Nebraska’s first class cities (population between 5,000 and 50,000). These funds can be used for any of the purposes outlined under STP funds above.	80%
TAP	<i>Transportation Alternatives Program:</i> Used for various activities such as: bicycle/pedestrian trails, landscaping, rehabilitation of historic structures and environmental mitigation.	80%
HSIP	<i>Highway Safety Improvement Program:</i> Used to carry out safety improvements on any public road or publicly owned bicycle or pedestrian trail.	90%
RRZ	<i>Rail Highway Hazard Elimination Program:</i> Used to construct new grade separation structures.	90%
HRRR	<i>High Risk Rural Road Program:</i> Used to carry out construction on roadways functionally classified as rural collectors and local roads.	90%
RRX	<i>Rail Crossing Protection:</i> Used to improve rail highway crossings.	90%
SRTS	<i>Safe Routes to School Program:</i> Used for projects to improve the ability of students to walk or bike to school.	100%
SPR	<i>State Planning and Research:</i> Used by NDOT for planning and research activities.	80%
PL	<i>Metropolitan Planning:</i> Allocated to metropolitan areas to carry out transportation planning processes required by federal law.	80%
PLH/ FLH	<i>Public Lands Highways/Forest Lands Highways:</i> projects within, adjacent to or providing access to public lands or forest highways.	100%
DPS/ DPU/ EM	<i>Earmarks:</i> Used for specific projects designated in federal legislation.	Varies
ER	<i>Emergency Relief:</i> Emergency repairs and restoration of federal aid highways damaged by natural disasters or catastrophic failures.	80% - 100%

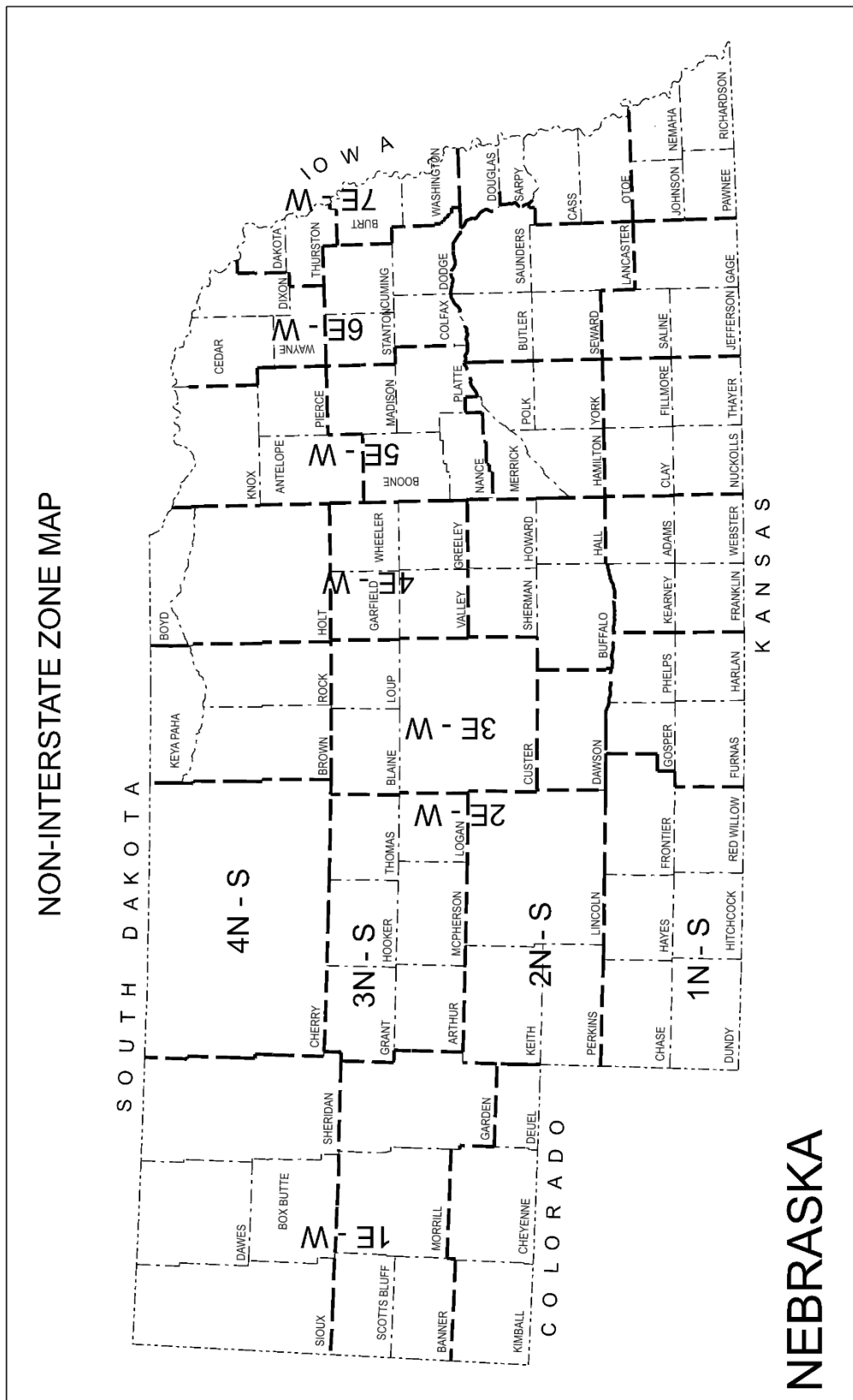
**Project Prefixes**

**State Funded Project Prefixes**

<b>Prefix</b>	<b>Description</b>	<b>Comments</b>
S	Resurfacing, rehabilitation or reconstruction of state highways.	100% State Highway Cash Fund
SRR	Resurfacing, rehabilitation or reconstruction of roads into or within state parks and recreational areas.	100% SRR funds for roads within parks. 90% SSR, 10% local for exterior roads.
NFG	State grade crossing funds used for rail crossing protective devices and closures.	100% NFG funds
TMT	Train Mile Tax: State tax on rail traffic used for constructing, rehabilitating, relocating or modifying railroad grade separation structures.	Up to 100% TMT funds
RD	Restoration and rehab projects such as armor coat, fog seal, joint and crack seal, asphalt and concrete patching.	100% State Highway Cash Fund
STR	Minor structure work such as bridge or box culvert repair.	100% State Highway Cash Fund
MISC	Minor projects such as culvert repair, landscaping or minor grading.	100% State Highway Cash Fund
ELEC	Minor electrical projects such as lighting and traffic signals.	100% State Highway Cash Fund

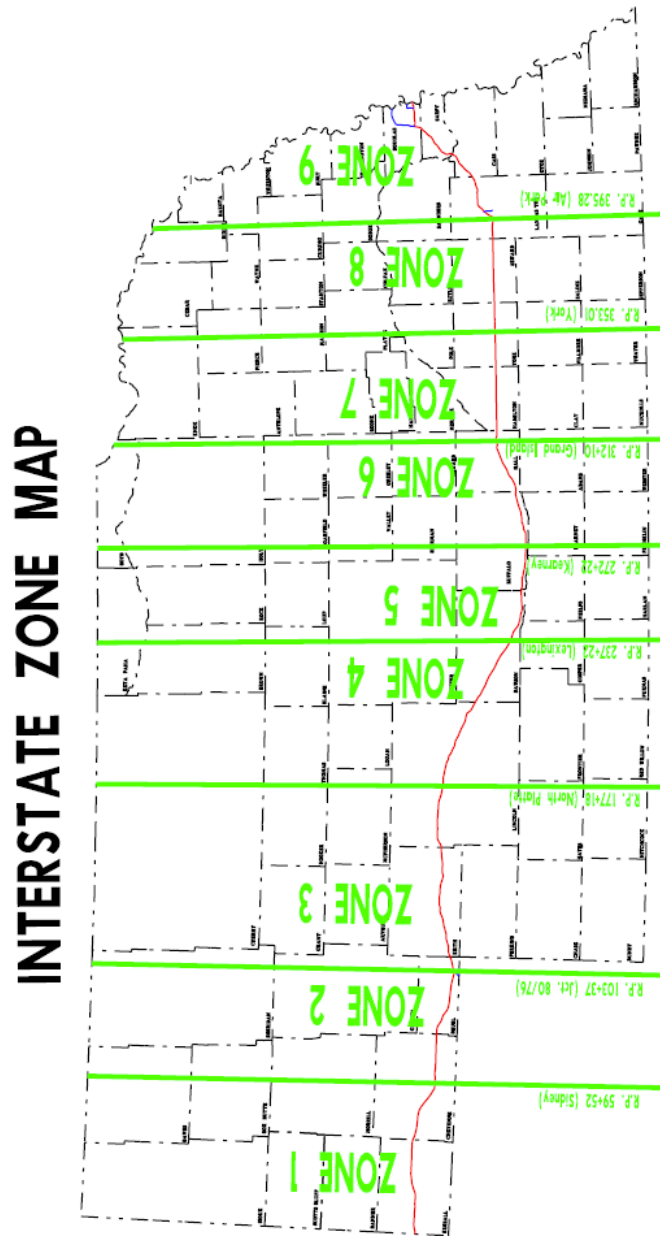
**HIGHWAY NUMBERS BY DIRECTION**

Highway No.	Direction	Highway No.	Direction	Highway No.	Direction
1	West-East	39	South-North	84	West-East
2	West-East	40	West-East	85	South-North
4	West-East	41	West-East	87	South-North
5	South-North	43	South-North	88	West-East
6	West-East	44	South-North	89	West-East
7	South-North	45	South-North	91	West-East
8	West-East	46	South-North	92	West-East
9	South-North	47	South-North	94	West-East
10	South-North	50	South-North	95	West-East
11	South-North	51	West-East	97	South-North
12	West-East	52	South-North	98	West-East
13	South-North	53	South-North	99	South-North
14	South-North	56	West-East	103	South-North
15	South-North	57	South-North	105	South-North
16	South-North	58	South-North	109	South-North
17	South-North	59	West-East	110	South-North
18	West-East	61	South-North	112	South-North
19	South-North	62	West-East	116	South-North
20	West-East	63	South-North	121	South-North
21	South-North	64	West-East	128	West-East
22	West-East	65	South-North	131	South-North
23	West-East	66	West-East	133	South-North
24	West-East	67	South-North	136	West-East
25	South-North	68	South-North	137	South-North
25A	South-North	69	South-North	138	South-North
26	West-East	70	West-East	159	West-East
27	South-North	71	South-North	183	South-North
29	South-North	73	South-North	250	South-North
30	West-East	74	West-East	275	West-East
31	South-North	75	South-North	275B	West-East
32	West-East	77	South-North	281	South-North
33	West-East	78	South-North	283	South-North
34	West-East	79	South-North	370	West-East
35	South-North	81	South-North	385	South-North
36	West-East	83	South-North		
38	West-East				



**INTERSTATE ZONES**

<b>Zone No.</b>	<b>Location</b>	<b>Interstate Route No.</b>
1	Wyoming State Line – Sidney	80
2	Sidney – I-76	80
3	I-76 – North Platte	76, 80
4	North Platte – Lexington	80
5	Lexington – Kearney	80
6	Kearney – Grand Island	80
7	Grand Island – York	80
8	York – West Lincoln	80
9	West Lincoln – Omaha	80, 180, 480, 680
1	South Sioux City Spur– Iowa Line	129



Nebraska Department of Transportation  
Operating Instruction 45-01  
December 8, 2017

## UTILITY REHABILITATION NEGOTIATIONS

1. **Purpose:** To provide policy for negotiating the relocation and adjustment of utility facilities concerning the basis of payment to the utility and for requesting federal participation in the non-betterment costs. The office of primary responsibility for this DOT-OI is the Roadway Design Division. This DOT-OI supersedes DOT-OI 45-1 dated February 15, 2000.
2. Highway construction projects frequently require the revision and relocation of utilities. Reimbursable costs represent the eligible non-betterment expenditures of the utility required to accomplish these revisions and relocations. These expenditures may be paid on a lump sum or actual cost basis and with state funds only or, under certain conditions, federal participation may be requested. See Federal-Aid Policy Guides 23 CFR 645A, "Utility Relocations, Adjustments, and Reimbursement, and 23 CFR 645B, "Accommodation of Utilities."
3. Federal participation in utility agreements normally will be requested only under the following conditions, where:
  - A. Federal funds available to Nebraska would increase substantially. Generally, this would be the case if the federal appropriations type is one of the following: Interstate, Emergency Relief, Discretionary Bridge Replacement, Demonstration, or Defense Access.
  - B. Federal funds available to Nebraska are in danger of lapsing if not obligated.
  - C. A need exists to accelerate the obligation of federal funds to utilize obligation authority by administratively imposed deadlines.
  - D. Local contributors specifically request federal participation and would be required to provide a greater share of project costs if federal participation was not approved.
4. Subject to the approval of the Roadway Design Division Engineer, the Utilities Engineer or Assistant Roadway Design Division Engineer may recommend the following actions:
  - A. Designation of various utility items as non-participating for federal funds on any project, regardless of appropriation type, when technical engineering and administrative difficulties indicate it would be impractical and uneconomical to request approval of federal participation, except when the use of state or local funds is illegal.

Operating Instruction 45-01

- B. Negotiation of lump-sum agreements with utility companies when the non-betterment portion of the utility rehabilitation estimate is \$25,000 or less and federal participation is not to be requested.
- C. Negotiation of lump-sum agreements with utility companies in accordance with Federal-Aid Policy Guide 23 CFR 645.113 when the non-betterment portion of the utility rehabilitation estimate is \$25,000 or less and federal participation is to be requested.
- D. Processing actual cost agreement final billings of \$25,000 or less as lump sum payments when federal participation is not to be requested (not requiring a contract audit).

Khalil Jaber, P.E.  
Deputy Director-Engineering



Nebraska Department of Transportation  
Operating Instruction 45-2  
January 31, 2018

## UTILITY AND RAILROAD PAYMENTS

### SECTION 1: UTILITY PAYMENTS – Roadway Design Division

1. **Purpose:** To provide policy for expediting payments to utility and railroad companies. The office of primary responsibility for SECTION 1 is the Roadway Design Division. The office of primary responsibility for SECTION 2 is the Local Assistance Division. This DOT-OI supersedes DOT-OI 45-2 dated July 5, 2005.

2. Highway construction projects frequently require the installation, revision, and relocation of utility facilities. Costs incurred are borne entirely by the companies until reimbursed by the state or other governmental subdivisions. This instruction is intended to minimize the time that company funds are tied-up in work related to department activities. Prompt partial and progress payments to utility companies will be made upon receipt of detailed company billings. Retained amounts due on final billings will be paid promptly upon completion of applicable department or FHWA audit procedures.

#### 3. The Controller Division will:

- A. Make up to a 95 percent partial payment to utility companies upon receipt of progress or final billing and a written request from the Roadway Design Division Engineer or the Utilities Engineer.
- B. Make immediate and full payment to utility companies of "lump sum" type billings that are submitted in accordance with previously executed agreements or as recommended for payment by the Roadway Design Division Engineer or the Utilities Engineer.

#### 4. The Roadway Design Division will:

- A. Advise the utility companies of their option of submitting periodic progress billings to avoid unnecessary tie-up of their funds pending submission of one final and complete detailed bill to include any applicable cost shares.
- B. Municipal utility facility reimbursement policy is set forth in DOT-OI 60-11, Municipal Cost Sharing, 3, F, (1)(2)(3).

Operating Instruction 45-2

## **SECTION 2: RAILROAD PAYMENTS – Local Assistance Division**

1. Highway construction projects frequently require the installation, revision, and relocation of railroad facilities. Costs incurred are borne entirely by the companies until reimbursed by the state or other governmental subdivisions. This instruction is intended to minimize the time that company funds are tied-up in work related to department activities. Prompt partial and progress payments to railroad companies will be made upon receipt of detailed company billings. Retained amounts due on final billings will be paid promptly upon completion of applicable department or FHWA audit procedures.

### **2. The Controller Division will:**

- A. Make 100 percent partial payment to railroad companies upon receipt of progress or final billing and a request from the Highway Liaison Manager in the Local Assistance Division.
- B. Make immediate and full payment to railroad companies of "lump sum" type billings that are submitted in accordance with previously executed agreements or as recommended for payment by the Highway Liaison Manager in the Local Assistance Division.
- C. Forward a copy of each railroad payment accounting coding document to the Local Assistance Division.

### **3. The Local Assistance Division will:**

- A. Advise the railroad companies, but not necessarily as part of agreements, of their option of submitting progress bills to avoid unnecessary tie-up of their funds pending submission of final billings.

Khalil Jaber, P.E.  
Deputy Director-Engineering

Nebraska Department of Transportation  
Operating Instruction 45-5  
March 31, 2021

## AGREEMENTS

1. **Purpose:** To provide policy for the preparation, distribution, and disposition of agreements between the department and an outside party. The office of primary responsibility is the Project Development Division. This DOT-OI supersedes DOT-OI 45-5 dated January 17, 2001.
2. Due to the extensive number of agreements, the variable nature of technical performance, and the governmental requirements originating in many different areas, the Project Development Division (PDD) will prepare, coordinate, distribute, monitor, and maintain departmental agreements, excluding those agreements associated with bid lettings, right-of-way acquisition, purchasing, and the contracts and bonds for highway construction. Those divisions which normally prepare their own agreements, or use a standard form of agreement, will submit prepared agreements to the PDD for review prior to execution by outside parties.
3. When necessary, managers will request that agreements be prepared by the PDD and will submit a NDOT Form 65, "Request for Agreement."
4. Agreements will be reviewed "in-house" by the Controller Division and PDD prior to execution by any party.
5. Except for standard agreements which have had prior review, all agreements prepared outside the PDD should be submitted to the PDD for review before negotiations are begun. When a standard agreement is revised, it should also be submitted for review.
6. The originating office is responsible for obtaining the signatures of parties outside the department. Following execution by an outside party, agreements will be **hand-carried** to the PDD for internal coordination.
7. Internal coordination will be accomplished by using a RDP Form 656-A, "Agreement Monitoring System - Agreement File Update." The originating office will complete the description and coordination portion of the form. The computer portion will be completed by the PDD.
8. Individuals to whom agreements are routed for coordination will promptly coordinate and have the agreement hand-carried to the next office indicated on the coordination sheet and immediately advise the PDD, via telephone, if he/she disagrees with the contents of the agreement or believes that further coordination with other offices is required.
9. Signatory responsibility for agreements is defined by DOT-OI 45-6.

Operating Instruction 45-5

10. Following execution by the department and approval (when necessary) of the FHWA, the PDD will coordinate with the originating office for the distribution of the agreements. The department's original, or a copy if the department is not a party to the agreement, will be retained in the PDD files. The PDD will then enter the basic data into the computerized agreement monitoring system.
11. Agreements retained in the PDD files will be microfilmed after ten years from the execution date. At that time, most originals will be destroyed. Agreement microfilm cards and a reader are available in the PDD for use by others.
12. The agreement number, which is a descriptive number indicating the originating office, agreement type, year, and sequence will be used by the PDD for filing purposes. Cross-reference listing by the agreement number, control number, and project number will be available in the PDD.
13. **Requirements for Agreement Preparation and Review:**
  - A. **Offer, acceptance, and a "meeting of the minds":**
    - (1) The preliminary definition of performance specifications is normally established through personal contact and written proposals.
    - (2) Where federal financing is involved, it is imperative to caution against beginning work before receiving notice to proceed, since work performed before federal authorization is ineligible for federal reimbursement.
    - (3) Failure of the contracting parties to interpret and understand all contract provisions identically tends to generate misunderstandings, disagreements, and legal problems. Accordingly, check each contract or agreement carefully for clarity and complete coverage of performance requirements as it affects each party to the contract.
    - (4) A "closing conference" with all parties is highly recommended on agreements containing complex performance details to assure complete understanding before contract execution.
  - B. **Cost Principles:** Managers will establish cost principles for use in determining the allowability of individual items of cost. These cost principles will be appropriately identified or referenced in each contractual document. If federal-aid is involved, cost principles will be those established by the applicable provisions of the governing Federal-Aid Highway Program Manual, grant agreement, Office of Management & Budget circular, other directives, and the contract cost principles and procedures set forth in the Federal Acquisition Regulations System (48 CFR, 1.31), as appropriate.

**C. Consideration:**

- (1) Check each agreement to see if the following are clearly answered. What are the pay items? When will payment be made? How will the amount to be paid be determined? Who is to be paid and who pays? Form of payment, i.e., cash offset against cost sharing, etc.?
- (2) In some cases, the requirement of consideration may be satisfied without monetary payment for work performance. An example of this would be obtaining covenants from counties, cities, and other political subdivisions to cause certain restrictions and to perform certain acts in consideration of the department making certain highway revisions either on its own behalf, or as an agent for the FHWA.

**D. Performance:**

- (1) Extra care and attention in defining and describing the detailed work to be done will do much toward eliminating misunderstanding, extra correspondence, and the need for supplemental agreements. Check each agreement carefully to see if the following are clearly answered. What is to be done? When will it be done? Where will it be done? Who will do it? How will it be done?
- (2) Attention should be directed to provisions in event of nonperformance.
- (3) Where applicable, attention should be directed to provisions concerning the handling of credits for materials recovered.

**E. Authority:** Contracts and agreements should be thoroughly checked for accurate inclusion, reference, and compliance with applicable laws, rules, and regulations.

**F. Cost Sharing:** Contracts and agreements should be reviewed for clear definition of the participants, sharing formula, when participants contribute, and how participants contribute.

**G. Covenants:** Contracts and agreements should be reviewed for clear definition of stewardship, liability, inspection, audit permission, retention of records, Disadvantaged Business Enterprises, and nondiscrimination.

**H. Guidelines for Requesting Contract and Agreement Reviews from the Legal Counsel:**

- (1) Agreements covering simple work performance and nominal amounts of consideration -- no review necessary.
- (2) Standard agreements and contracts -- request a review once for form and legal sufficiency unless changed and after each state legislative session or issue/revision of applicable FHWA publications.

Operating Instruction 45-5

- (3) Agreements and contracts involving complex provisions – review regardless of consideration amount.
- (4) Formulation of policy is not a responsibility of the Legal Counsel. Questions involving policy will be taken to the applicable deputy director.

**I. Guidelines for Requesting Contract and Agreement Reviews by the Operational Analysis & Audit Division (OAAD):**

- (1) Contracts exceeding \$50,000 must be sent to the OAAD for a pre-award audit.
- (2) Contracts not based on a firm, fixed price must go to the OAAD for a post-audit to determine the total allowable contract costs.

**J. General Guidelines:**

- (1) Avoid indefinite or ambiguous language and be explicit. The terms "and/or" should never be used.
- (2) Insure that each agreement includes all of the proper parties, but not more parties than necessary to perform the subject of the agreement.
- (3) Do not automatically make the state a party to every agreement -- only when necessary.
- (4) FHWA publications will be included by reference, as applicable.

Khalil Jaber, P.E.  
Deputy Director-Engineering

Nebraska Department of Transportation  
Operating Instruction 45-06  
March 31, 2021

## DELEGATION OF AUTHORITY

1. **Purpose:** To provide policy, delegate authority, and establish accountability for selected financial obligations and activities. The office of primary responsibility is the Controller Division. This DOT-OI supersedes DOT-OI 45-06 dated December 8, 2017.

### 2. Annual Operating Budget:

- A. Division Heads and District Engineers, or their designee, are responsible for the preparation and management of their annual operating budget.
- B. Deputy Directors are responsible for reviewing and approving the annual operating budgets for their respective areas of responsibility.
- C. The Director will review and approve the Department's annual operating budget.
- D. Any adjustments to the Division/District operating budgets must be approved by the Division Head/District Engineer and will be submitted to the Controller Division on an Allotment Change form BF-9. The Controller Division will request the approval of the Resource Manager, Deputy or Director for any adjustments deemed necessary.

### 3. Six-Year Plan for Highway Construction:

- A. The Deputy Director-Engineering, in consultation with the State Highway Commissioners, District Engineers, and appropriate Division Heads, is responsible for annually updating the Nebraska Surface Transportation Program.
- B. The Nebraska Surface Transportation Program and changes thereto must be submitted to the Director for approval.

### 4. Computer Development Projects:

Computer technology project ideas and proposals must be submitted to the Business Technology Support Division (BTSD) Project Management Officer (PMO) using the Business Technology Project Proposal form provided by BTSD. The PMO will assign a Project Manager and they will work with the submitter to fully understand the desired outcome of the project and develop preliminary estimates of time, cost and resources to complete the project. The project proposal will be forwarded to the Information Technology Management Team (ITMT) for their approval. The project sponsor(s) may be invited to a meeting to review the project proposal with the ITMT. The ITMT will then decide to either approve or reject the project proposal.

Operating Instruction 45-06

If the project proposal is approved, a BTSD Project Manager will begin working with the submitter to establish the project team, develop the project charter and begin collecting business requirements. Once the project charter has been completed, it must be approved by the project sponsor(s). If the project charter includes a major change or addition to the project scope as determined by the BTSD Management Team, it will be forwarded to the ITMT for their approval. The project sponsor(s) may be invited to a meeting to review the project charter with the ITMT. The ITMT will then decide to continue with the project, or go back to the original project scope or reject the project.

The ITMT consists of the Deputies, Director and BTSD Manager.

The BTSD Management Team consists of the BTSD Manager, Project Management Officer and Technical Services Officer.

The BTSD Project Manager will be the person to manage the project based off of the BTSD Project Management Methodology and will be assigned by the BTSD Management Team.

## 5. Contracts and Agreements:

- A. Agreements related to state highway projects with cities, counties, utilities, and irrigation districts shall be executed by the Division Head responsible for administering the agreement. District Engineers shall provide their concurrence for these agreements. Unusual or complicated agreements may be referred to the appropriate Deputy for signing. Relinquishment agreements will be executed by a Deputy Director in accordance with DOT-OI 60-13.
- B. Agreements related to state highway projects with federal agencies, state agencies, and other states must be submitted to the Director, or appropriate Deputy Director in the Director's absence, for execution. **Exception:** A Deputy Director or the appropriate Division Head, responsible for administering the agreement, may execute routine agreements.
- C. Other agreements (such as service, research, registered land surveying, underground fuel leak investigations, and consultant agreements) will be executed by the Division Head or District Engineer responsible for administering the agreement.
- D. Construction contracts awarded through the letting process will be executed by the Deputy Director-Engineering, Construction Engineer or Contract Lettings Engineer.
- E. Construction contract progress estimates, final payments, tentative acceptance and as-built plans shall be approved by the District Engineer, the District Construction Engineer or Assistant District Construction Engineer in the absence of the District Engineer.



Operating Instruction 45-06

- F. The below individuals shall have approval to execute construction project change orders and supplemental agreements for the following limited amounts:
- (1) District Engineer or District Construction Engineer: \$0.00 - \$100,000
  - (2) Construction Engineer: \$100,000 - \$250,000
  - (3) Deputy Director – Operations or Deputy Director – Engineering: over \$250,000
- G. District Engineers, District Construction Engineers or District Operations and Maintenance Managers shall approve all NDOT let capital facilities project pay estimates, change orders and supplemental agreements.
- H. The Local Projects Engineer shall approve the following requests, agreements and supplemental agreements:
- (1) All Local Public Agency (LPA) Project Programming Requests, NDOT Form 530.
  - (2) All LPA project program agreements and supplemental project program agreements.
  - (3) Consultant agreements and supplemental agreements as to form, for preliminary engineering and NEPA services for LPA Federal-aid projects and for Recreation Road projects. Local Projects Section Sections Heads may approve these agreements in lieu of the Division Head.
  - (4) All NE-LTAP agreements with NDOT and FHWA. Design exceptions for LPA's and public interest letters (ROW conditional certifications, force account work, sole source purchases) for LPA's shall have final approval by the Deputy Director – Engineering.
- I. The Construction Division Head or designee shall approve as to form consultant professional services agreement and supplemental agreements for construction engineering and design services during construction for LPA Federal-aid projects and for Recreation Road projects.
- J. State Highway Improvement Programming Requests, NDOT Form 73, shall be approved by the Deputy Director – Engineering and the Program Management Engineer. Approval by the Deputy Director – Engineering may be delegated to specific Division Heads, as shown below, when the improvement request involves their functional areas.
- (1) Resurfacing, Restoration and Rehabilitation (3R), new and reconstruction – Roadway Design Engineer.
  - (2) Maintenance – Materials and Research Engineer.
  - (3) Traffic Signals/Sign Projects – Traffic Engineer.

Operating Instruction 45-06

- (4) Bridge Only Projects – Bridge Engineer.
  - (5) Railroad Upgrade/Circuitry/Warning Devices – Intermodal Planning Engineer.
  - (6) Right-of-Way Only Projects – Right of Way Manager.
  - (7) Intermodal Transportation System Projects – Operations Manager.
- K. All State Transportation Improvement Program requests (STIP) shall be approved by the Program Management Engineer or the Highway Projects Funds Manager.
- L. The following documents shall be approved by the Right-of-Way Manager or to a specific Section Head in the Right-of-Way Division such as the Right-of-Way Design Engineer, Chief Appraiser, Chief Negotiator/Relocation Supervisor, Highway Beautification Supervisor or Property Management Supervisor.
- (1) Consultant Service Contracts
    - [a] Right-of-Way Design
    - [b] Title Search
    - [c] Appraisal and/or Appraisal Review
    - [d] Relocation Assistance
  - (2) Acquisition contracts for the purchase of right-of-way.
  - (3) Demolition contracts for the demolition of buildings/improvements in the right-of-way.
  - (4) Clearing/grubbing contracts let through the Right-of-Way Division for tree removal.
  - (5) Agreements for state services. (*Right-of-Way Division only*)
  - (6) Right-of-Way certificates
- M. Approval authority for various Local Public Agency documentation shall be delegated to section heads in the Right-of-Way Division as follows, with one exception. Local Public Agency Right-of-Way certificates shall be approved by the Right-of-Way Division Manager.
- (1) Right-of-Way Plan approval delegated to the Right-of-Way Design Engineer.
  - (2) Preliminary Right-of-Way Estimate approval delegated to the Chief Appraiser.
  - (3) Appraisal/Appraisal Review approval delegated to the Chief Appraiser.

Operating Instruction 45-06

- (4) Relocation Assistance delegated to the Chief Appraiser/Relocation Supervisor.
  - (5) Acquisition approval delegated to the Chief Negotiator/Relocation Supervisor.
  - (6) Project Review delegated to the Right-of-Way Local Public Agency Coordinator.
6. **Miscellaneous:** The Project Concept Review (engineering review) for each state highway construction project must be approved by the District Engineer, the Roadway Design Engineer and the Deputy Director-Engineering.

Khalil Jaber, P.E.  
Deputy Director-Engineering

**This Page Intentionally Left Blank**

Nebraska Department of Transportation  
Operating Instruction 60-09  
December 18, 2017

## CORRIDOR PROTECTION

1. **Purpose:** To provide policy for establishing corridor protection on state highways and notifying the public that corridor protection has been filed. The office of primary responsibility for this DOT-OI is the Right-of-Way Division. This DOT-OI supersedes DOT-OI 60-9 dated April 24, 2012.
2. Highways in areas having the potential to develop prior to a planned highway improvement will be reviewed for corridor protection as defined in Sections 39-1311 through 39-1311.05, Nebraska Statutes. If there is a need for corridor protection, a recommendation will be made by the Project Development Division, Roadway Design Division, Right-of-Way Division, or District Engineer.
3. The following are required before initiating corridor protection for a project on a **new alignment**: (a) a location public hearing, (b) if applicable, FHWA approval of the draft environmental impact statement, (c) a State Highway Commission recommendation, and (d) approval by the Governor. For a project on an **existing alignment**, the above requirements are unnecessary in order to initiate corridor protection.
4. The Project Development Division, Roadway Design Division, or Property Management Section of the Right-of-Way Division will write a letter to the Right-of-Way Division Manager, through the Deputy Director - Engineering, requesting that corridor protection procedures be initiated on the proposed project (See Attachment). Copies of the letter will be sent to the Project Development Division, Roadway Design Division, District Engineer, Property Management Section, and Right-of-Way Design Section of the Right-of-Way Division.
5. For projects using an existing alignment for which it is deemed necessary to file corridor protection, a strip 300 feet wide will be designated on both sides of the existing right-of-way. In the case of projects on a new alignment, a strip 400 feet wide on both sides of the proposed centerline will be designated for corridor protection. These widths are guidelines and may vary depending on the terrain and design. Projects will have corridor protection procedures initiated after the project concept and alignment has been defined.
6. The Right-of-Way Design Section will begin title research and prepare corridor protection maps after the corridor centerline, length, and width have been established by joint action of the Project Development Division, Roadway Design Division, and Right-of-Way Division. After a corridor protection plan is completed by the Right-of-Way Design Section, said plan will be sent to the Property Management Section.
7. The Property Management Section will file the corridor protection plan with the appropriate city and/or county officials as outlined in Sections 39-1311 through 39-1311.05, Nebraska Statutes. A signed receipt will be obtained from the appropriate governmental official receiving the corridor protection plan, acknowledging that such plan has been received.

Operating Instruction 60-09

8. The Property Management Section shall send an annual notice to each zoning authority and all utility companies as listed with the Utilities Unit of the Roadway Design Division, where corridor protection is currently filed. This notice shall be prepared in April of each year.
9. After corridor protection has been filed, functional plans will be prepared to determine the right-of-way requirements. After the functional plans are completed, they will be reviewed to determine if an amended corridor protection plan should be filed. An amended corridor protection plan is filed in the same manner as an original filing.
10. The Property Management Section will forward copies of the corridor protection map and the signed filing receipt to the Project Development Division, Roadway Design Division, District Engineer, and Highway District Right of Way Permits Officer.
11. At appropriate locations along the proposed highway project, the District Engineer will erect signs which are visible to the public and which state that corridor protection has been filed.
12. The Property Management Section shall obtain approvals for the release of a corridor protection project from the District Engineer, Roadway Design Engineer and the Project Development Engineer on an annual basis. Such requests for release shall be routed in January of each year.
13. The Property Management Section will promptly notify the appropriate city and/or county official of corridor protection release after receiving approval from the District Engineer, Roadway Design Engineer and the Project Development Engineer.

Attachment #1 of 1

Khalil Jaber, P.E.  
Deputy Director-Engineering

Operating Instruction 60-09

DATE \_\_\_\_\_

TO Right-of-Way Division Manager

FROM Location Studies Section Engineer \_\_\_\_\_

THRU Project Development Division Engineer \_\_\_\_\_  
Deputy Director-Engineering \_\_\_\_\_

SUBJECT Request for Corridor Protection  
Project No. \_\_\_\_\_  
Location: \_\_\_\_\_  
C.N. \_\_\_\_\_

The design of the project ( \_\_\_\_\_ ) will be along  
1) the existing highway alignment, 2) on new alignment. Corridor protection is needed for the  
area annotated on the attached map. Notes: (that corridor protection has already been  
established along US-75 south of the N-2 junction.)

After concurrence by the Deputy Director, please initiate the process to provide corridor  
protection at this location. The Project Development Division will supply additional information  
as may be necessary.

Attachment

xc: Project Development Division  
Roadway Design Division  
District Engineer  
Property Management Section  
Right-of-Way Design Section

DOT-OI 60-09  
Attachment #1

**This Page Intentionally Left Blank**



Nebraska Department of Transportation  
Operating Instruction 60-10  
December 29, 2017

## ADA ACCESSIBILITY REQUIREMENTS IN TRANSPORTATION PROJECTS

1. **Purpose:** The State of Nebraska, Department of Roads, (NDOT), will include accessibility features in applicable construction and maintenance projects or activities on the transportation systems for which it has jurisdictional responsibility as required by the Rehabilitation Act of 1973 and the Americans with Disabilities Act of 1990 (ADA) and as further defined and clarified in the Americans with Disabilities Act Accessibility Guidelines (ADAAG) <https://www.access-board.gov/adaag-1991-2002.html>. The office of primary responsibility is the Roadway Design Division. This DOT-OI supersedes DOT-OI 60-10 dated May 13, 2009.
2. **Scope:** This DOT-OI establishes policy for accessibility of pedestrian facilities on street or highway projects on the State Highway System, the National Highway System (NHS), and for local projects funded in whole or in part with state or federal highway funds. This DOT-OI shall be considered in conjunction with DOT-OI 60-11 which details the financial responsibilities of project participants.

### A. Projects or Activities Subject to the Requirements of this Policy:

- (1) New Construction projects (Section 3A)
- (2) Reconstruction projects (Section 3B)
- (3) Other construction projects that meet any of the following criteria (Section 3C):
  - (a) Pavement overlays with a design thickness of 1.5 inches or greater
  - (b) Pavement repair or patching that requires replacement of curb within a crosswalk that does not currently have a curb ramp
- (4) Traffic signal installation or reconstruction (Section 3D)
- (5) Construction Projects on Local Roads and Streets (Section 3E)
- (6) Roadway Maintenance Activities (Section 3F)
- (7) Construction Authorized by Right-of-Way Permits (Section 3G)

Operating Instruction 60-10

**B. Projects or Activities Excluded From the Requirements of this Policy:** The following projects or activities are excluded from the requirements of this policy provided that the work does not create an elevation difference greater than 0.5 inches at the gutter line in a crosswalk.

- (1) Constructing chip seals, sand seals, microsurfacing, fog seals or armor coats
- (2) Patching or repairing potholes
- (3) Striping or re-striping roadways including crosswalks
- (4) Maintaining, repairing, replacing or upgrading roadside safety devices such as guardrail or median barrier
- (5) Maintaining and repairing traffic signals as further identified in Section 3D
- (6) Maintaining, repairing, replacing or upgrading permanent traffic control signs and devices
- (7) Constructing overlays by milling and resurfacing with a design thickness of less than 1.5 inches
- (8) Placing overlays with a design thickness of less than 1.5 inches
- (9) Pavement repair or patching that does not require replacement of curb within a crosswalk
- (10) Maintaining or repairing roadside shoulders
- (11) Sealing pavement joints and cracks
- (12) Grinding or profiling pavement surface
- (13) Patching or repairing of utility pavement cuts
- (14) Constructing, maintaining, repairing, replacing or upgrading of roadway lighting
- (15) Maintaining or repairing drainage systems
- (16) Retrofitting pavement with dowel bars
- (17) Repairing or replacing sidewalk panels
- (18) Other work not specifically covered by Section 3

Although the above listed Projects or Activities are exempt from the requirements of this Policy, any Project or Activity that requires the closure of a sidewalk shall conform to the requirements of Section 4.

Operating Instruction 60-10

3. **Accessibility Policy for Applicable Projects or Activities:** The following shall apply to projects or segments of projects.
- A. **New Construction Projects** – New construction projects are constructed in a new location and are designed to meet the new and reconstructed requirements of the Nebraska Minimum Design Standards. Accessibility features will be included to the extent required by the AADAG.
  - B. **Reconstruction Projects** – Reconstruction projects are projects designed to conform to the new and reconstructed requirements of the Nebraska Minimum Design Standards in an existing location of a roadway. Accessibility features will be included to the extent technically feasible as provided by the AADAG.
  - C. **Other Pavement Projects** – Other pavement projects include:
    - Pavement overlays with a design thickness of 1.5 inches or greater
    - Pavement repair or patching that requires replacement of curb within a crosswalk that does not currently have a curb ramp

The following subsections apply to other pavement projects:

- (1) **Curb Ramps** – Curb ramps will be constructed within project limits. Curb ramps should be constructed, or reconstructed when necessary, whenever an activity listed in Section 2.A. alters the pavement in a crosswalk. When an activity causes a differential in elevation in gutter line at a crosswalk with a curb ramp in excess of 0.5 inches, the differential must be eliminated.
- (2) **Landing Area of the Curb Ramp** – Whenever a new curb ramp is installed as a part of a project, the landing area on the sidewalk side of the curb ramp will be evaluated to identify and implement, if reasonable, other improvements to provide an open and useable landing area. For example, reasonable steps should be taken to relocate signs and other objects to a location outside of the landing area.
- (3) **Sidewalk** – New sidewalks will not ordinarily be installed and existing sidewalks will not ordinarily be replaced except as necessary to create a transition from the new curb or landing area to the adjacent sidewalk. Based on Neb. Rev. Stat. §§ 39-2105 and 39-1339, generally, cities and villages have the duty to construct, operate, and maintain sidewalks and curb ramps along the state highway system within the corporate limits.
- (4) **Driveways** – Ordinarily, driveways will not be replaced or reconstructed as a part of this policy.

Operating Instruction 60-10

**D. Installation or Reconstruction of Traffic or Pedestrian Signals** – The following shall apply when a traffic signal is installed or rebuilt and pedestrian or bicycle traffic is expected to be present within the next five years:

- (1) Assess the need and install accessible pedestrian signals with the work when necessary.
- (2) Install curb ramps necessary for the proper functioning of the traffic signal.
- (3) Install sidewalks to connect the curb ramps to the existing pedestrian routes. If no connecting sidewalks currently exist within the limits of the project, the NDOT shall build sufficient sidewalk to access the pedestrian push button and enter into an agreement for the local entity to complete the sidewalks at a later time.

The following shall apply when a pedestrian or school crossing traffic signal is installed or reconstructed:

- (1) Assess the need and install accessible pedestrian signals with the work when necessary.
- (2) Install curb ramps necessary for the proper functioning of the traffic signal.
- (3) Install sidewalks to connect the curb ramps to the existing pedestrian routes. If no connecting sidewalks currently exist within the limits of the project, NDOT shall enter into an agreement for the local entity to complete the sidewalks.

Traffic signal, pedestrian signal or school crossing signal installation or reconstruction completed by a municipality or as part of a right-of-way permit or agreement shall meet the requirements of this section. In addition, work that is performed by a developer as a part of a right-of-way permit shall include the construction of all necessary connecting sidewalks or trails.

When a signal is installed, or reconstructed, the need for accessible pedestrian signals shall be studied and if warranted integrated into the pedestrian push button to the extent required in Public Rights-of-Way Accessibility Guidelines (PROWAG).

For the purposes of this policy, reconstruction of a traffic signal shall not include routine maintenance, repair of the traffic signal, replacement of signal heads, replacement of any cabinet components, or replacement of poles, mast arms, signal components or controller cabinet.

Traffic signal installations at locations where pedestrians are not allowed to cross should have signs indicating no crosswalk. Traffic signal installations at locations where pedestrians are not expected within the next five years should not include the installation of pedestrian signals unless there is an engineering basis for such installation.

Operating Instruction 60-10

**E. Construction Projects on Roads and Streets Off the State Highway System –**  
Local street or road projects funded in whole or in part with federal or state funds or activities on the NHS regardless of funding must be designed and constructed in compliance with this policy.

- (1) The local entity has a duty to ensure that the project plans and specifications comply with the applicable requirements. NDOT is authorized, but not required, to confirm the local entity's completion of its duty under this paragraph.

If the local entity declares it is not technically feasible to comply with a particular accessibility requirement, the local entity shall submit to the NDOT Local Projects Engineer documentation from a professional engineer licensed to practice in the State of Nebraska that describes how meeting the specific requirement is technically infeasible and a design plan showing how the local entity intends to make the facility accessible to the maximum extent feasible.

The Local Projects Engineer shall review and approve or deny the proposed design plan. Any deviations from the ADAAG must meet the test of technically infeasible.

- (2) The NDOT will apply the requirements of this document in the following manner:

- (a) Each agreement between NDOT and a local entity shall contain the following language:

“The local entity shall comply with the requirements of the Rehabilitation Act of 1973 and Title II of the Americans with Disabilities Act of 1990 (ADA), and applicable federal regulations and standards to the extent required by the policy “ADA Accessibility Requirements in Transportation Projects.”

- (b) The local entity shall not submit a project for letting unless it or its consultant has confirmed that the project is in compliance with the ADA and ADAAG.
- (c) The local entity shall certify to NDOT that the project has been constructed in substantial compliance with the plans and specifications and that the completed construction complies with the requirements of Title II of the ADA, applicable federal regulations, and the ADAAG to the extent required by this policy.

Operating Instruction 60-10

F. **Roadway Maintenance Activities** – Generally, maintenance activities (Section 2B) are not alterations and are not subject to the requirements of this policy except to the extent specifically identified below.

- (1) Curb ramps shall be installed when pavement repair or patching requires the replacement of a curb within a crosswalk that does not have existing curb ramps.
- (2) The accessibility of a crosswalk will be restored to pre-activity conditions whenever surface maintenance of the highway causes a 0.5 inch differential in the surfacing within the crosswalk. The 0.5 inch differential will need to be eliminated either by tapering or grinding.

G. **Construction Authorized by Right-of-Way Permits** – Right-of-way permits issued or agreements entered into by NDOT including the construction or modification of pedestrian facilities shall contain the condition that the permittee will comply with the requirements of this policy, applicable federal regulations, and the ADAAG. Permits shall not be issued for work until an engineer, licensed to practice in the State of Nebraska, has certified to NDOT that the plans comply with this policy. NDOT is authorized, but not required to review the plans to confirm compliance with this policy. Traffic Impact Studies will be required to determine whether pedestrians are expected to be present at the site of the permitted construction and if so, what accessible pedestrian facilities are required. If the project is within the corporate limits of a municipality or its extra-territorial jurisdiction, the applicant should coordinate the need for constructing pedestrian facilities with the municipality. When accessible sidewalks or other pedestrian facilities are not constructed as part of a permitted project within the corporate limits of a municipality or its extra-territorial jurisdiction, the applicant shall enter into an agreement with the municipality stipulating the responsibility for completion of the accessible pedestrian facilities when required by this policy. The NDOT District Engineer or their designee has the right, but not the duty to verify through on-site inspection that the ADA facilities as constructed meet the requirements of the ADAAG and Public Rights-of-Way Accessibility Guidelines (PROWAG).

4. **Temporary Accessible Pedestrian Facilities:** Temporary accessible pedestrian facilities should be constructed when any primary accessible route or crossing will be blocked.

The person or entity in charge of the project or activity shall determine whether any of the pedestrian facilities within the limits of the project are used as a primary accessible route across the project or to an adjoining commercial, retail, medical or governmental property.

A primary accessible route or crossing is (a) a moderate to heavily used accessible crosswalk that serves as a connector between businesses with regular pedestrian traffic, or between parking areas and business, medical or governmental buildings dependent on such parking or (b) a public sidewalk used as a part of an accessible route to a business, when there is no reasonable alternate accessible route for customers traveling to that business.

Operating Instruction 60-10

In a business district, provision for one primary accessible crossing through the work zone shall be made at least every two blocks.

Temporary accessible pedestrian facilities should include accessibility features as practicable and reasonably consistent with the features present in the existing pedestrian facility.

Blocked sidewalks and re-designated accessible routes shall be marked in accordance with Section 6.D. of the MUTCD.

5. **Design Standards:** NDOT adopts the ADAAG as the design standard to be used when facilities are designed pursuant to this policy. NDOT will design to the standards of the Public Rights-of-Way Accessibility Guidelines (PROWAG) whenever the requirements of the PROWAG exceed the requirements of ADAAG. NDOT and FHWA anticipate that the PROWAG will be published as a final rule and be incorporated into the Federal Regulations. In the event the Federal Regulations are revised to establish PROWAG as a design standard, NDOT shall meet its requirements. FHWA has indicated in a memo dated January 23, 2006 that the PROWAG is the state of the practice and shall be used for design except when the ADAAG is more restrictive.
6. **Resolving Accessibility Complaints:** It is the District Engineer's responsibility to resolve complaints concerning the accessibility of pedestrian facilities on highway right-of-way. Complaints shall be handled in an expeditious manner to ensure the timely resolution of all complaints. Complaints received in offices outside the District Office will be sent to the attention of the District Engineer for investigation and resolution. When received in the District, a copy of the complaint will be forwarded to the State of Nebraska ADA Contact, 301 Centennial Mall South, Mall Level, P.O. Box 94905, Lincoln, NE 68509-4905, the NDOT Civil Rights Coordinator in the Human Resources Division and to the Roadway Design Engineer. The DAS Statewide Civil Rights Coordinator is responsible for monitoring the resolution of these complaints. The Roadway Design Division will function as a resource during resolution of the complaints. The NDOT Civil Rights Coordinator shall develop and update forms for the Pedestrian Accessibility Complaint Process and Request for Modification Process. These documents along with the State's ADA Complaint Procedure are available on the Department's web site or from the NDOT Civil Rights Coordinator.
7. **Technically Infeasible:** The ADA provides a limited exception to meeting the accessibility requirements for projects and activities altering an existing facility when it is technically infeasible to meet those requirements. Section 4.1.6 (1) (j) of the ADAAG states as follows:

EXCEPTION: In alteration work, if compliance with Section 4.1.6 is technically infeasible, the alteration shall provide accessibility to the maximum extent feasible. Any elements or features of the building or facility that are being altered and can be made accessible shall be made accessible within the scope of the alteration.

Operating Instruction 60-10

'Technically infeasible' is defined in the ADAAG as follows:

*Technically Infeasible.* Means, with respect to an alteration of a building or a facility, that it has little likelihood of being accomplished because existing structural conditions would require removing or altering a load-bearing member which is an essential part of the structural frame; or because other existing physical or site constraints prohibit modification or addition of elements, spaces, or features which are in full and strict compliance with the minimum requirements for new construction and which are necessary to provide accessibility.

After exhausting all reasonable alternatives, it may sometimes be determined under this policy that strict adherence to all accessibility requirements may not be technically feasible. A design that does not meet the requirements may be allowed when consistent with this section.

A. The following is a nonexclusive list of situations when an exception may be considered:

When ADAAG slope requirements cannot be met because of the difference in elevation between the highway and:

- (1) the floor elevation of existing buildings or structures;
- (2) the topography or geography of the area adjoining the project;
- (3) the elevation of intersecting streets and roads.

When building the project in strict compliance with the ADAAG would cause:

- (1) the project to encroach on an environmentally sensitive or protected area;
- (2) the project to not conform with minimum design standards;
- (3) the project to negatively affect historic property, park lands, tribal lands or other similar properties;
- (4) an adverse effect on the safety of the traveling public.

B. In determining whether a finding of technical infeasibility under the ADAAG should be granted, the NDOT may consider the availability of a reasonable alternate accessible route.



Operating Instruction 60-10

- C. When it is asserted that compliance with a particular standard is technically infeasible, documentation shall be submitted to the NDOT Roadway Design Engineer that describes why all the requirements cannot be met and providing a design complying to the fullest extent possible. The request for an exception shall provide all necessary facts showing that a design in strict adherence would qualify as technically infeasible. The request shall include a complete description of the work considered to be beyond the scope of the transportation improvement that would be required. Cost to make a facility accessible is a consideration but is not a determining factor.
- D. The Roadway Design Engineer has the authority to approve or deny requests by NDOT and others for an exception based on a finding of technical infeasibility.
8. **Maintenance of Accessible Facilities:** Based on Neb. Rev. Stat. §§ 39-2105 and 39-1339, generally, cities and villages have the duty to construct, operate, and maintain new and existing sidewalks and curb ramps along the state highway system within the corporate limits. Construction, operation, and maintenance of facilities constructed outside the corporate limits shall be addressed by agreement with the local agency or the Sanitary Improvement District.
9. **Training:** The NDOT will provide training required to implement this policy.
10. **NDOT Publications:** The NDOT Roadway Design Manual and Standard/Special Plans, the NDOT Construction Manual, the NDOT Right-of-Way Manual and the NDOT Maintenance and Operations Manual shall be amended or supplemented by the Division responsible for each manual as appropriate to provide guidance for ADA accessibility issues.
11. **Documentation:** Documentation of project specific decisions related to accessibility shall be kept in the project records and archived as required by the records retention policy. Non-project related decision documents shall be retained in the appropriate file in the District and archived according to the records retention policy. All documentation shall be copied to the appropriate folder in the NDOT document management database.

Khalil Jaber, P.E.  
Deputy Director-Engineering

**This Page Intentionally Left Blank**

Nebraska Department of Transportation  
Operating Instruction 60-11  
April 28, 2020

## MUNICIPAL COST SHARING

1. **Purpose:** To provide policy for the calculation of the municipal share of project costs for projects on **non-freeway** state highways located within or adjacent to the corporate limits of a municipality. Project costs include costs for preliminary engineering, eligible utility rehabilitation, construction, right-of-way and construction engineering. This policy applies to all **non-freeway** state highway projects including: “New and Reconstructed” projects, “Resurfacing, Restoration and Rehabilitation” (3R) projects, and “Maintenance” projects. This policy does not apply to projects determined by the Department to be “wants” or economic development projects. Projects classified as “wants” are projects that do not satisfy a state highway transportation need or that exceed the recognized need. Economic development projects are projects that are being built primarily to accommodate adjacent economic development. The office of primary responsibility for this DOT-OI is the Roadway Design Division. This DOT-OI supersedes DOT-OI 60-11 dated December 3, 2013. This policy is in compliance with and supplementary to Nebraska Revised Statutes.
2. **Statutory References:** Neb. Rev. Stat. §§ 39-1339 and 39-2105 (See Attachment A).
3. **State Highways Abutting, Adjoining or Adjacent to the Municipal Corporate Limits:**
  - A. In accordance with Sections 5, 6, and 7, a municipal corporation will be required to participate in the cost of the entire width of a project if:
    - (1) A portion of a state highway abuts, or adjoins the corporate limits of the municipality, or
    - (2) A portion of a state highway that is adjacent to the corporate limits when it appears to the Department that the state highway is being used by municipal traffic as if it were within the corporate limits of the municipality.
  - B. Apportionment of costs will be based upon the municipal corporate limits existing on the date that the department signs the municipal agreement.
4. **Agreements:**
  - A. Projects involving a municipal contribution: The Department and municipality shall enter into a written agreement establishing the scope of the project and a tentative construction schedule. It is the intent of the Department that the project be coordinated throughout the project term with the municipality.

Operating Instruction 60-11

- B. Projects involving no municipal contribution: When a municipality is not required to make a financial contribution to a project, a written agreement for parking restrictions, encroachments, municipal-owned utilities, and other matters is required. If an existing municipal maintenance agreement adequately covers parking restrictions, encroachments, municipal-owned utilities, and other aspects of the project, and if no financial participation or change in participation is required, no new or modified agreement is necessary.

**5. Municipal Share – all Municipalities:**

- A. A municipality will not be required to share in project costs if the estimated municipal share is \$10,000 or less.
- B. Unless addressed elsewhere herein, a municipality will pay 100 percent of the project costs of a project that is at the request of and for the sole benefit of the municipality.
- C. A municipality will pay 100 percent of the costs of improvements constructed at the request of the municipality which are beyond the scope of and are not warranted by the highway project.
- D. Relinquishment Projects: Municipalities will not normally share in the cost of projects accomplished as part of a relinquishment agreement. Improvements under these projects will be based upon DOT-OI 60-13, Relinquishment of Roads from the Highway System.

**E. Traffic operations and lighting systems:**

- (1) The project costs for traffic signals and/or lighting systems, not part of a “New and Reconstructed”, “3R”, or “Maintenance” project, will be allocated 50 percent to the Department and 50 percent to the municipality. Project costs include the cost of all work required for the construction of the traffic signals and/or lighting systems, such as intersection geometric improvements.
- (2) The municipality will pay 100 percent of the cost of operating, repairing and maintaining the traffic signal and/or lighting system.
- (3) Roundabouts will be part of the project costs when the Department deems them necessary. The municipality will pay 100 percent of the difference in project costs when a roundabout is built at their request in lieu of the Department’s recommended design.

**F. Rail/highway grade crossing safety projects:**

- (1) Project costs will be funded with a combination of state, federal, local and railroad funds. The cost sharing on specific projects will be determined by an agreement between the parties involved. Eligible project items may include preliminary and construction engineering, right-of-way, utilities, and construction costs.

Operating Instruction 60-11

- (2) Railroad companies require that the construction of all pedestrian viaducts must incorporate a chain link fence as part of a rail safety project. The chain link fence must be a minimum of six (6) feet high and extend along the railroad track right-of-way for a minimum of 500 feet in each direction from the pedestrian viaduct, on both sides of the track. NDOT agrees to participate in a one-time maximum payment of \$40,000 to the municipality for fence construction. NDOT assumes no other liability or involvement beyond said financial participation. Municipalities will be responsible for 100% of the cost of obtaining all necessary right-of-way, construction, and maintenance of said fence, as well as any necessary reconstruction costs. These terms will be included in the project agreement with the municipality.

**G. Highway and Municipal Drainage Facilities:**

- (1) Definitions:

**Highway drainage facilities** are the facilities designed to collect and drain waters from the highway, the right-of-way and adjoining lands. These highway drainage facilities are usually located within the highway right-of-way.

**Municipal drainage facilities** are the facilities used by the municipality for the drainage of waters including waters draining from the highway drainage facilities. These municipal drainage facilities are usually located outside of highway right-of-way.

**Additional drainage waters** are the increased waters reaching the drainage facilities due to the project being built.

- (2) Apportionment of costs:

Highway drainage facilities: Costs will be shared as a project cost.

Municipal drainage facilities: The municipality will pay all costs associated with the upgrade of municipal drainage facilities.

- (3) Drainage design – No additional drainage waters:

The Department will design its highway drainage facilities to collect and discharge storm water based on the design guidelines set out in the Roadway Design Division's "Drainage Design Manual", if feasible, based on all applicable considerations. When the highway drainage facilities connect or drain into the municipal drainage facilities, the Department will calculate and notify the municipality of the capacity of the municipal drainage facilities necessary to convey waters away from the highway. When the capacity of the municipal drainage facilities does not comply with the Department's design guidelines, the Department will notify the municipality that it should upgrade its municipal drainage facilities. The Department will request, for safety and liability reasons, that the municipality commit to one of the plans for upgrading their municipal drainage facilities as described below:

Operating Instruction 60-11

- (a) The municipality provides the Department with reasonable written assurances of a present plan for a future upgrade of its municipal drainage facilities. The municipality shall provide the Department with the details of its proposed improvements that will convey the design hydraulic event determined by the Department.
- (b) The municipality requests that the project include an upgrade of its municipal drainage facilities to be paid for solely by the municipality, and the municipality shall enter into an agreement with the Department concerning this upgrade of its facilities prior to the Department beginning the design of the project.

If the Department determines that significant additional drainage waters will be conveyed to the municipal drainage facilities because of the design of the project, the Department will determine, on a case-by-case basis, whether the municipal drainage facilities will be upgraded and whether the Department will share in any portion of the cost of such upgrade. The extent of the upgrade to the municipal drainage facilities and the division of cost for such upgrade will be a matter of negotiation to be resolved and set forth in an agreement with the municipality.

**H. Municipal Utility Reimbursement Policy:**

- (1) Non-betterment relocation of municipality-owned utilities made necessary by the construction or reconstruction of state highways within the municipal corporate limits are eligible as a project cost. The relocated municipality-owned utilities shall meet all applicable standards or codes that govern the installation, operation, and maintenance of said facilities.
- (2) All relocation of municipality-owned utilities made necessary by the construction or reconstruction of state highways outside the corporate limits and located within the state right-of-way are not eligible for reimbursement by the Department.
- (3) Non-betterment relocation of municipality-owned utilities due to construction or reconstruction of state highways which are located outside the corporate limits and outside the state right-of-way are eligible as a project cost for reimbursement by the Department. The relocated municipality-owned utilities shall meet all applicable standards or codes that govern the installation, operation, and maintenance of said facilities.
- (4) Any municipality-owned utility cost that is eligible as a project cost will be included in the project cost sharing. When it is determined that a municipality is required to participate in the cost of a project, the cost sharing will be in accordance with Sections 5, 6, and 7.

Operating Instruction 60-11

- I. **Americans with Disabilities Act (ADA) Compliance:** The municipality will be responsible for 100 percent of the costs for upgrading existing sidewalks and curb ramps to meet ADA accessibility guidelines, which are outside the normal scope of the project and are at the request of the municipality.

**6. Municipal Share – Municipalities with a Population of 5,000 or Less:**

- A. Except as provided in this section, the municipality with a population of 5,000 or less will not ordinarily be required to participate in the cost of a project.
- B. **On Highway Parking Areas:** The municipality will pay 100 percent of the costs of constructing additional parking areas and the reconstruction of existing parking areas, which are at the request of the municipality. One hundred percent of the costs of resurfacing existing parking areas will be the responsibility of the Department.
- C. **Federal-Aid Safety Projects:** The minimum municipal share is 20 percent of the total cost of a federal-aid safety project for projects on streets or roads that are not on the state highway system. At the discretion of the Strategic Safety Infrastructure Projects Team, federal-aid safety projects with a municipal share can have a cap on federal-aid safety funds. No municipal contribution is required for a federal-aid safety project on the state highway system.
- D. **Americans with Disabilities Act (ADA) Upgrades – Sidewalks and Curb Ramps:**
  - (1) **“New and Reconstructed” Projects:** The municipality will not be required to share in the costs of constructing or reconstructing sidewalks and curb ramps when included in the normal scope of a “New and Reconstructed” project.
  - (2) **“3R” or “Maintenance” Projects:**
    - (a) Sidewalks will not ordinarily be reconstructed as a part of a “3R” or “Maintenance” project, unless the municipality requests that sidewalks be reconstructed, at its sole cost, as a part of the project.
    - (b) Curb ramps will be constructed or reconstructed to meet federal and state accessibility guidelines under “3R” and “Maintenance” projects at no cost to the municipality. The cost of constructing or reconstructing sidewalk required to blend these curb ramps into the adjoining sidewalk will also be performed at no cost to the municipality.

**7. Municipal Share – Municipalities with a Population Over 5,000:**

- A. Municipalities with a population over 5,000 may be required to participate in the cost of a project within, or in some instances, adjacent to the corporate limits of the municipality.

**B. Computation of Total Cost for “New and Reconstruction” Projects:**

A municipality’s project cost share shall be based on the number of thru-traffic lanes as described below. Where the number of lanes is in transition, the start and end points for the differing number of lanes shall be at the mid-point of each transition. Turn lanes, medians, parking areas and surfaced shoulders shall not be considered to be thru-traffic lanes.

- (1) **Projects including no more than two thru-traffic lanes:** Except as provided in Section 5 of this DOT-OI, the municipality will not be required to share in the cost of a project that includes no more than two thru-traffic lanes.
- (2) **Projects including no more than four thru-traffic lanes:** Except as provided in Section 5 of this DOT-OI, the municipality will pay 20 percent of the project cost attributable to any portion of the project that includes four thru-traffic lanes.
- (3) **Projects including more than four thru-traffic lanes:** Except as provided in Section 5 of this DOT-OI, the municipality will pay a share of the cost of the project attributable to any portion of the project that includes more than four thru-traffic lanes. The municipality’s share will be based upon the number of thru-traffic lanes in excess of the lesser number of lanes entering or leaving the municipality, however, the municipality’s minimum share will be 20 percent.

**Example one:** If the highway enters the municipality with two thru-traffic lanes and leaves the municipality with four thru-traffic lanes and the project has a two thru-traffic lane segment, a four thru-traffic lane segment and a six thru-traffic segment, the municipal cost share is 0 percent of the cost of the two thru-traffic lane segment, 20 percent of the cost of the four thru-traffic lane segment and 66.67 percent of the cost of the six thru-traffic lane segment of the project.

**Example two:** If the highway enters and leaves the municipality with four thru-traffic lanes and the project has a four thru-traffic lane segment and a six thru-traffic lane segment, the municipal cost share is 20 percent of the cost of the four thru-traffic lane segment and 33.33 percent of the cost of the six thru-traffic lane segment of the project.

**Example three:** If the highway enters and leaves the municipality with six thru-traffic lanes and the project has a six thru-traffic lane segment and an eight thru-traffic lane segment, the municipal cost share is 20 percent of the six thru-traffic lane segment and 25 percent of the cost of the eight thru-traffic lane segment of the project.

**C. Computation of Total Cost for “3R” and Maintenance” Projects:**

A municipality’s project cost share shall be based on the number of thru-traffic lanes as described below. Where the number of lanes is in transition, the start and end points for the differing number of lanes shall be at the mid-point of each transition. Turn lanes, medians, parking areas and surfaced shoulders shall not be considered to be thru-traffic lanes.



Operating Instruction 60-11

- (1) The municipality's share will be the cost of the number of thru-traffic lanes in excess of the lesser number of thru-traffic lanes entering or leaving the municipality.

**Example one:** If the highway enters and exits the municipality with two thru-traffic lanes and the project has a two thru-traffic lane segment and a four thru-traffic lane segment, the municipal cost share is 0 percent of the cost of the two thru-traffic lane segment and 50 percent of the cost of the four thru-traffic lane segment of the project.

**Example two:** If the highway enters and exits the municipality with four thru-traffic lanes and the project has a four thru-traffic lane segment and a six thru-traffic lane segment, the municipal cost share is 0 percent of the cost of the four thru-traffic lane segment and 33.33 percent of the cost of the six thru-traffic lane segment of the project.

**Example three:** If the highway enters the municipality with two thru-traffic lanes and exits the municipality with four thru-traffic lanes and the project has a two thru-traffic lane segment, a four thru-traffic segment and a six thru-traffic lane segment, the municipal cost share is 0 percent of the cost of the two thru-traffic lane segment, 50 percent of the cost of the four thru-traffic lane segment and 66.67 percent of the cost of the six thru-traffic lane segment of the project.

**Example four:** If the highway enters the municipality with four thru traffic lanes and exits the municipality with six thru-traffic lanes and the project has a four thru-traffic lane segment, a six thru-traffic lane segment and an eight thru-traffic lane segment, the municipal cost share is 0 percent of the cost of the four thru-traffic lane segment, 33.33 percent of the cost of the six thru-traffic lane segment and 50 percent of the cost of the eight thru-traffic lane segment of the project.

- (2) Municipalities will not normally share in the cost of resurfacing projects accomplished as part of a relinquishment agreement.
- (3) Because funding is limited and because many municipalities have their own annual resurfacing programs, District Engineers may elect to allow the municipality to design, let, and construct municipal resurfacing projects. In such cases, the preliminary and construction engineering costs are 100 percent the responsibility of the municipality. Resurfacing projects on the highway system let by the municipality shall include elimination of barriers to access as defined under the Americans with Disabilities Act and subsequent Federal regulations or technical guidance.

**D. Bridges:**

- (1) The municipal share of the total cost of new construction, replacement, rehabilitation, redecking, widening and placing a structural overlay, and adding sidewalks to bridges will be determined pursuant to Section 7.B. Construction of additional width for lanes or sidewalks beyond that which is existing or under contract by the municipality shall be constructed at the municipalities cost.

Example: If the Department is replacing a two-lane bridge with an existing sidewalk on one side and the municipality requests that the new bridge accommodate a planned but not contracted three lane section with a shared use path on one side and a sidewalk on the other, the additional costs associated with the additional lane and the additional width of walkway would be 100% municipal cost.

- (2) In general, bridge maintenance work will not require municipal cost participation (i.e. polymer deck overlays, abutment repair, pier repair, deck repair, joint repair, curb repair, curb replacement, and approach slab repair).

**E. Americans with Disabilities Act (ADA) Compliance – Sidewalks and Curb Ramps:**

- (1) **“New and Reconstructed” Projects:** The municipality will share in the costs of constructing or reconstructing sidewalks and curb ramps to meet state and federal accessibility regulations and technical guidance when included in any “New and Reconstructed” project as a project cost.
- (2) **“3R” or “Maintenance” Projects:**
  - (a) Sidewalks will not ordinarily be reconstructed as a part of a “3R” or “Maintenance” project, unless the municipality requests that sidewalks be reconstructed, at its sole cost, as a part of the project.
  - (b) Elimination of barriers to access including the construction of curb ramps will be constructed or reconstructed to meet state and federal accessibility regulations and technical guidance under “3R” and “Maintenance” projects with resurfacing of any thickness. The municipality will share in the cost of eliminating barriers to access including constructing or reconstructing curb ramps, and sidewalk construction or reconstruction required to blend these curb ramps into the adjoining sidewalk as a project cost.

- F. **On Highway Parking Areas:** The municipality will be responsible for 100 percent of the costs of constructing additional parking areas and/or the reconstruction or resurfacing of existing parking areas, which are at the request of the municipality.

Operating Instruction 60-11

**G. Federal-Aid Safety Projects:**

- (1) **Municipality is Responsible Charge:** The municipal share of a federal-aid safety project either **on** or **off** the highway system, and the **Municipality is the Responsible Charge**, is 100 percent of the Preliminary Engineering, Final Design, and NEPA Services costs of the projects and a minimum of 10 percent of the Right-Of-Way, Utilities, Construction, and Construction Engineering costs of the project. At the discretion of the Strategic Safety Infrastructure Projects Team, federal-aid safety projects with a municipal share can have a cap on federal-aid safety funds.
- (2) **NDOT is Responsible Charge:** The municipal share of a federal-aid safety project either **on** or **off** the state highway system and **NDOT is the Responsible Charge** is a minimum of 20 percent of the total cost of the project, including Preliminary Engineering, Final Design, NEPA Services, Right-of-Way, Utilities, Construction, and Construction Engineering. At the discretion of the Strategic Safety Infrastructure Projects Team, federal-aid safety projects with a municipal share can have a cap on federal-aid safety funds.

**H. Traffic Signals and Lighting Systems:** For the purpose of determining the municipal share of traffic signals and/or lighting systems installed as part of a “New and Reconstructed”, “3R”, or “Maintenance” project, the costs are considered a project cost. The municipality will pay 100 percent of the cost of operating, repairing and maintaining the traffic signal and/or lighting system. The municipal agreement will detail the municipality’s duties and responsibilities related to operation, maintenance and repair of the traffic signal or street lighting systems.

Khalil Jaber, P.E.  
Deputy Director-Engineering

**ATTACHMENT "A"**

Neb. Rev. Stat. § 39-1339

State highway system; connecting links, defined; duty of department.

Except as provided in section 39-1372, the responsibility of the department for the maintenance of connecting links on the state highway system shall be determined in accordance with the following provisions:

- (1) The department shall be liable for the cost of surface maintenance of the traveled way of connecting links, not including the parking lanes thereon, in cities of the metropolitan, primary, and first classes; PROVIDED, such connecting links were constructed under the authority of the department and construction costs were paid in whole or in part with county, state or federal-aid funds. The department shall not be responsible for the maintenance of any connecting link or portion thereof, which was not built in whole or in part with county, state or federal-aid funds;
- (2) The department shall be liable for all of the surface maintenance of the traveled way of connecting links, including parking lanes thereon, in cities of the second class and villages; PROVIDED, such connecting links were constructed under the authority of the department and construction costs were paid in whole or in part with county, state or federal-aid funds. The department shall not be responsible for the maintenance of any connecting link or portion thereof which was not built with county, state or federal-aid funds;
- (3) The responsibility of the department for the maintenance of the connecting links, described in subdivisions (1) and (2) of this section, shall be limited to such things as are caused either by wear and tear of travel on such connecting links or by acts of God. Maintenance shall not be construed to include (a) snow removal, (b) maintenance caused by constructing, placing, replacing, repairing, or servicing water mains, sewers, gas lines, pipes, utility equipment, or other similar things placed beneath, across, or upon the surface of any portion of a connecting link, or (c) repairs or reconstruction going beyond the scope or normal surface maintenance or wear and tear of travel;
- (4) The maintenance of structures, on the connecting links described in subdivisions (1) and (2) of this section, shall not be limited to the traveled way but shall include the entire structure; PROVIDED, the department shall have no responsibility for the maintenance of appurtenances to such connecting links and the structures thereon, except by special agreement with the city or village in which the connecting link is situated. Appurtenances shall include, but are not limited to, sidewalks, storm sewers, guardrails, handrails, steps, curb or grate inlets, driveways, fire plugs, or retaining walls;

Operating Instruction 60-11

- (5) The department shall maintain and keep in repair all public bridges and the approaches thereto when located in cities of the first class and on connecting links, which were constructed under the authority of the department and construction costs were paid in whole or in part with state or federal funds;
- (6) Nothing contained in this section shall be construed to prevent the department from entering into special agreements with cities or villages regarding the reconstruction and maintenance of connecting links in such cities and villages; and
- (7) As used in this section, unless the context otherwise requires, connecting link shall mean a street now designated as a state highway.

Neb. Rev. Stat. § 39-2105  
Functional classifications; jurisdictional responsibility

Jurisdictional responsibility for the various functional classifications of public highways and streets shall be as follows:

- (1) The state shall have the responsibility for the design, construction, reconstruction, maintenance, and operation of all roads classified under the category of rural highways as Interstate, expressway, and major arterial, and the municipal extensions thereof, except that the state shall not be responsible for that portion of a municipal extension which exceeds the design of the rural highway leading into the municipality. When the design of a rural highway differs at the different points where it leads into the municipality, the state's responsibility for the municipal extension thereof shall be limited to the lesser of the two designs. The state shall be responsible for the entire Interstate system under either the rural or municipal category, and for connecting links between the Interstate and the nearest existing state highway system in rural areas, except that if such a connecting link has not been improved and sufficient study by the Department of Transportation results in the determination that a link to an alternate state highway would provide better service for the area involved, the department shall have the option of providing the alternate route, subject to satisfactory local participation in the additional cost of the alternate route;
- (2) The various counties shall have the responsibility for the design, construction, reconstruction, maintenance, and operation of all roads classified as other arterial, collector, local, and minimum maintenance under the rural highway category;
- (3) The various incorporated municipalities shall have the responsibility for the design, construction, reconstruction, maintenance, and operation of all streets classified as expressway, which are of a purely local nature, that portion of municipal extensions of rural expressways and major arterials which exceeds the design of the rural portions of such systems, and responsibility for those streets classified as other arterial, collector, and local within their corporate limits; and

Operating Instruction 60-11

- (4) Jurisdictional responsibility for all scenic-recreation roads and highways shall remain with the governmental subdivision, which had jurisdictional responsibility for such road or highway prior to its change in classification to scenic-recreation made pursuant to this section and sections 39-2103, 39-2109, and 39-2113.

Note – The Department has defined the phrase “exceeds the design”, as used in the Statutes, to apply to the overall design of the roadway including the number of thru-traffic lanes entering or leaving the municipality. Because a municipal design and a rural design differ as far as appurtenances and drainage, the Department has established 20% as the minimum participation for new and reconstruction projects with four thru lanes within cities of the first class. Further refinement of the municipal participation rate will be based upon the actual number of thru-traffic lanes built with the project compared to the number of thru lanes entering or leaving the municipality. The test of “excess” in design applies to any point where the highway enters and/or leaves the municipality and not necessarily at the site of the improvement. Department policy defines the point where the highway enters and/or leaves the municipality to be the corporate limits of the municipality.

Website for Chapter 39 Nebraska Highway and Bridge Law State Statutes  
<http://uniweb.legislature.ne.gov/laws/browse-chapters.php?chapter=39>

Nebraska Department of Transportation  
Operating Instruction 60-12  
October 23, 2019

## Cost Sharing for Local Roads Crossing Freeways and Expressways

1. **Purpose:** To provide policy for determining the local (city or county) share of project costs on local roads crossing or intersecting state highway freeways and expressways. The office of primary responsibility for this DOT-OI is the Roadway Design Division. This DOT-OI supersedes DOT-OI 60-12 dated September 3, 2003.
2. Off-system crossroad and interchange improvements:
  - A. When the Department is constructing or upgrading an off-system crossroad over or under a freeway or expressway as a part of a new or reconstructed freeway or expressway project, it is Department policy that the “project” will fund construction of the crossroad to match the existing typical<sup>1</sup> section of the crossroad. If a county or city desires the crossroad to be constructed to an expanded typical section (multiple lanes), the county or city shall pay for all costs, associated with the crossroad, in excess of those required to match the existing typical section.
  - B. When no Department freeway or expressway expansion project is planned and a county or city desires to expand the typical section of an off-system crossroad passing over or under a freeway or expressway, the county or city shall pay for all expansion costs.
3. Distribution of cost savings resulting from changes in the number or design of local roads crossing or connecting to a freeway.
  - A. When the Department is planning a freeway reconstruction project, the “base” design must first be established and cost estimated. This is usually replacing those local facilities “in kind”. If the parties agree to eliminate a city or county road grade separation, the Department may apply up to the net cost savings to enhancing other features of the project of mutual interest, including other local roads within the project, with the following stipulations:
    - (1) A formal agreement is required.
    - (2) The savings cannot be applied to roads outside the project limits.
    - (3) The savings must be applied at the time of the Department’s project.
    - (4) The savings must be applied to features that meet but do not exceed the standards of the Board of Public Roads Classifications and Standards, and to features that fit within the local long-range comprehensive plan.

Khalil Jaber, P.E.  
Deputy Director-Engineering

<sup>1</sup> existing typical is defined as the typical section in place, or under contract by the city or county, at the time the Department conducts its project contract letting.

**This Page Intentionally Left Blank**



Nebraska Department of Transportation  
Operating Instruction 60-13  
February 12, 2018

## RELINQUISHMENT OF ROADS FROM THE HIGHWAY SYSTEM

1. **Purpose:** To provide policy for the relinquishment of roads, by preparation, distribution, and disposition of relinquishment agreements between the Nebraska Department of Transportation and an outside party. The office of primary responsibility for this DOT-OI is the Project Development Division. This DOT-OI supersedes DOT-OI 60-13 dated September 25, 2007.

2. **General:**

When a segment of highway is relocated, the functional classification of the old highway will be changed. The Department will offer to relinquish to the political or governmental subdivision(s) or public corporation(s), any portion of the old state highway that has been relocated. If an offer to relinquish a highway segment is not accepted by the local jurisdiction(s), the State may abandon it as provided by law (See Section 8 "Abandonment of Roadway"). The Department will relinquish the highway to the local agency after following the approved policy for relinquishment of highways.

Before relinquishment, the Department will evaluate the condition of the roadway to determine the need for any rehabilitation. It is the intent of the Department to only relinquish roads that will provide suitable service for the travelling public.

Other than surface rehabilitation, improvements to the roadway will not be made. At the time of relinquishment, the Nebraska Department of Transportation (NDOT) will assess the adequacy of structures and determine if any reparation or corrective action is required. It is the intent of the State to relinquish only those structures which are structurally and functionally adequate for the purpose for which they will be used.

In any relinquishment or closure proceeding where the NDOT owns fee simple title to the underlying land, ownership should be reserved by the NDOT. However, the land may be sold according to Nebraska Statute Sec. 39-1325. If sold, the contract must guarantee that utility companies have a perpetual right to utilize the former state right of way.

Whenever a public hearing for a highway project is held, the Department of Transportation's presentation will include a statement explaining the proposed changes in the highway system and the proposed segments of the existing highway to be relinquished to local jurisdiction.

A highway may be automatically relinquished by the state when its functional classification changes. However, it is preferable to acquire a signed relinquishment agreement with the County or City prior to highway removal or location approval.

The relinquishment or abandonment of a highway segment must be recommended by the NDOT and the Highway Commission and approved by the Governor. This action should take place at the location approval stage.

**3. Procedure for Completing Agreements:**

The Project Development Agreements Engineer is the activity manager for relinquishment activities in the Project Scheduling System (Clarity), and will initiate all agreements pertaining to relinquishments and changes in classification and jurisdictional responsibility. The development of the agreement will be according to the time frame defined in Clarity.

The activity manager will coordinate this effort with Roadway Design, Project Development, Right of Way, and the District Engineer (DE). Throughout this entire process, Clarity will be updated by the activity manager to reflect the progress of the relinquishment activity for each applicable project.

The Project Development Agreements Engineer will attend dry-run hearings to review projects with relinquishments.

**4. Covenant Agreement Process:**

**A. Expressway Projects**

Alignment concepts are studied by the Project Development Division. Example projects are expressway studies and could include, new railroad viaduct construction, major river crossings or city bypass routes.

- (1.) During the course of such studies, Project Development will discuss the possibility of relinquishment with the governmental entity affected. Whenever possible, a commitment in the form of a resolution or letter of intent to accept the relinquishment will be obtained from each governmental entity involved.
  - a. When potential changes in the National and/or State Functional Classification of roadways is an issue, Materials & Research, Functional Classifications Section staff will be a part of the discussion with Local entities.
- (2.) Once an alignment is selected as the preferred route, a location hearing is normally conducted. Relinquishment information is provided in the engineering presentation and public comment is received.
- (3.) The Agreements Engineer will be notified when a relinquishment agreement is needed, and will be advised of any special or specific information necessary to accurately define any previously agreed upon circumstances.
- (4.) The Agreements Engineer will prepare a covenant agreement covering the proposed relinquishments. The draft review process will include Project Development, Roadway Design, Roadway Asset Management Engineer, and the respective DE.

Operating Instruction 60-13

- (5.) If a petition or resolution has not been received from the local jurisdiction, then the relinquishment agreement will contain a paragraph stating that by signing the agreement, the governmental entity is petitioning the State to relinquish said State Highway, according to Nebraska Statute Section 39-1314.
  - (6.) The Agreements Engineer will be advised of any subsequent revision(s) or supplementals to the relinquishment(s), by the initiating division, and will prepare the necessary Supplemental Document(s).
  - (7.) The Agreements Engineer will send the agreement(s) to the appropriate DE to obtain the local signatures and certification.
- B. Non-Expressway Projects
- (1.) The Project Development Division or the Roadway Design Division will notify the Agreements Engineer when a Relinquishment agreement is needed.
  - (2.) Whenever possible, a commitment, in the form of a resolution or letter of intent to accept the relinquishment, will be obtained from each governmental entity involved.
  - (3.) If Clarity calls for action, the Agreements Engineer will notify Roadway Design that project details are needed to start the relinquishment process.
  - (4.) The Agreements Engineer will prepare a covenant agreement covering the proposed relinquishments. The draft review process will include Project Development, Roadway Design, Roadway Asset Management Engineer and the respective DE.
  - (5.) The Agreements Engineer will be advised of any subsequent revision(s) or supplementals to the relinquishment(s), by the initiating division and will prepare the necessary Supplemental Document(s).
  - (6.) The Agreements Engineer will send the agreement(s) to the appropriate DE to obtain the local signatures and certification.
- C. Expressway and Non-Expressway Projects
- (1.) The DE will receive agreement(s) from the Agreements Engineer and will obtain signatures from representatives of local jurisdiction(s).
  - (2.) The DE will return signed agreements to the Agreements Engineer.
  - (3.) The Agreement Monitoring System will be initiated and updated by the Agreements Engineer.

Operating Instruction 60-13

- (4.) The Agreements Engineer will file one completely executed agreement and will send other(s) to the District Engineer along with a copy in the District's file.
- (5.) The DE will return the fully executed agreement(s) to the local jurisdiction(s).
- (6.) The Agreements Engineer will be advised of any subsequent revision(s) or supplementals to the relinquishment(s), by the initiating division, and will prepare the necessary Supplemental Document(s).

**5. Final/Supplemental Agreement Process:**

- A. For all projects, if a covenant agreement exists, the Agreements Engineer will furnish a copy of the agreement to the Roadway Design Division for review and definition of reference points describing final areas of relinquishment. The Roadway Design Division will furnish the required geometric details to the Agreements Engineer for incorporation into the agreement.
- B. The Agreements Engineer will review all information with the applicable Division(s) to finalize the agreement.
- C. If not previously stated in the covenant agreement, and no petition of relinquishment exists, the agreement will contain a paragraph stating that by signing the agreement, the County or City is petitioning the State to relinquish said State Highway, according to Nebraska Statute Section 39-1314.
- D. A draft agreement will be sent to the: Roadway Asset Management Engineer; Roadway Design Division and the respective DE for review. If significant changes or additions are made during this review process, another review may be necessary.
- E. Appropriate changes will be made only with consensus, and will be accomplished by the Agreements Engineer.
- F. After final review, agreements will be provided to the DE by the Agreements Engineer.
- G. The DE will obtain signatures from representatives of local jurisdiction(s).
- H. The DE will return signed agreements to the Agreements Engineer.
- I. The Agreement Monitoring System will be initiated and updated by the Agreements Engineer.
- J. The Agreements Engineer will file one completely executed agreement and will send the other(s) to the DE along with a copy for the District's file.
- K. The DE will return the fully executed agreement(s) to the local jurisdiction(s).
- L. The Agreements Engineer will be advised of any subsequent revision(s) to the relinquishment(s), and prepare the necessary Supplemental Document(s).

**6. Internal Distribution:**

After the agreements are signed the following distribution will be made by the Agreements Engineer within the Department:

- (1.) Roadway Design
- (2.) Traffic Engineering
- (3.) Right of Way
- (4.) Controller: Maintenance Unit
- (5.) District Engineer
- (6.) Project Development: Project Studies & Survey Engineer
- (7.) Materials & Research: Roadway Asset Management Engineer
- (8.) Operations
- (9.) Materials & Research: Mapping Section

**7. Document Recording and Final Disposition:**

When the Right of Way Division receives notice of the executed agreement, they will file all necessary legal documents, for the relinquishment, at the appropriate County Office and notify the DE and the Agreements Engineer when the relinquishment was recorded.

The DE shall notify the appropriate local officials, in writing, with copies to: the Agreements Engineer, Roadway Asset Management Engineer, Director, all Deputy Directors, the appropriate Highway Commissioner, and all appropriate Division Heads, of the effective date of change of jurisdictional responsibility.

Roadway Asset Management Engineer will make the final Functional Classification submittal to the Federal Highway Administration, perform all the necessary documentary changes in functional classifications, update the official state highway and local road/street Functional Classification maps and make submittal action to the American Association of State Highway and Transportation Officials (AASHTO) for Route Number changes when necessary.

If necessary the Traffic Engineer will issue a highway route revision informing all concerned officials of the new highway location, number, and identify the old highway.

Operating Instruction 60-13

8. **Abandonment of Roadway:**

Projects should not progress to the design hearing stage without a signed agreement covering all relinquishments of highways affected by the project.

If the local government refuses to accept the relinquishment, the Department of Transportation will delay the project until an agreement with the local jurisdictions can be reached. If an agreement is not obtainable, the Department may abandon the segment as a public road, as provided by Section 39-1314 of State Statute, so the project may continue.

Khalil Jaber, P.E.  
Deputy Director – Engineering

Nebraska Department of Transportation  
Operating Instruction 60-16  
October 23, 2019

## POLICY FOR PHASE CONSTRUCTED 3R PROJECTS

1. **Purpose:** To provide policy for projects when construction is phased due to the condition of the pavement and time constraints necessary to develop a 3R project. The office of primary responsibility for this DOT-OI is the Roadway Design Division. This DOT-OI supersedes DOT-OI 60-16 dated June 5, 2012.

### 2. Scope:

A significant level of project development is required for “3R” projects in order to prepare them for letting. Occasionally the project development timeframe exceeds the remaining life of the pavement. In these cases, pavement condition and ability of the State maintenance forces to maintain the rapidly deteriorating roadway surface dictate that the rehabilitation of the surfacing occur prior to the projected letting of the project. This policy will allow for the phasing of the construction of the project to complete the surface rehabilitation as soon as possible and concurrently pursue the development of the remaining features necessary to meet the 3R standards such as culvert modification, widening, property acquisition, etc.

### 3. Policy:

It is the policy of the NDOT that when the construction of a project is phased due to the condition of the asset, a follow-up project addressing those design features requiring development to meet the design standards shall be let as soon as project development allows. The funds necessary to build the follow-up or “phase 2” project shall be set aside from the District’s allocation at the time the phase 1 project is awarded. These funds will not be redirected to a different purpose without the approval of the Deputy Director – Engineering.

The decision to construct a project in phases will be made by the Roadway Design Engineer following a request by the District Engineer and with the concurrence of the Program Management Engineer, the Materials and Research Engineer, and when appropriate, the Bridge Engineer.

Khalil Jaber, P.E.  
Deputy Director – Engineering

**This Page Intentionally Left Blank**



Nebraska Department of Transportation  
Operating Instruction 60-19  
July 24, 2020

## USE OF PROPRIETARY AND STATE FURNISHED ITEMS

1. **Purpose:** To provide policy for use of patented or proprietary (sole source) products and NDOT supplied material on NDOT roadway and bridge construction projects, (and Local Public Agency projects when let by NDOT). The office of primary responsibility for this DOT-OI is the Construction Division. This is a new DOT-OI.

2. **References:** 23 CFR Part 635 [FHWA Docket No. FHWA-2018-0036] RIN 2125-AF84 Construction and Maintenance – Promoting Innovation in Use of Patented and Proprietary Products, and 23 CFR 635.407.

3. **The FHWA revised its regulations** to provide greater flexibility for States to use proprietary or patented materials in Federal-aid highway projects. This final rule rescinds the requirements limiting the use of Federal funds in paying for patented or proprietary materials, specifications, or processes specified in project plans and specifications, thus encouraging innovation in transportation technology and methods. This final rule is effective October 28, 2019.

4. **The revision of the rule has prompted questions** regarding the required documentation for the use of sole source or proprietary products on NDOT construction projects. The use of sole source and the use of NDOT or LPA supplied material are addressed below.

### 5. Patented or Proprietary Products (Sole Source)

NDOT and LPA adhered to the Federal regulations when Patented or Proprietary items are used in a state-let construction project. In order to maintain the integrity of the letting process, the change in the Federal regulations has created the need to develop a policy for NDOT and LPA projects when a proprietary product is specified. Regardless of funding type, NDOT policy requirements are as stated below.

This policy will apply when:

- NDOT or LPA specifies a proprietary in Federal-aid contracts, or
- NDOT or LPA references a single trade name material in specifications and on plans, or
- NDOT or LPA specifies proprietary products on their Approved Products List (APL) or Nebraska Qualified Material Vendors List (NQMVL), or
- NDOT or LPA uses specifications where only one manufacturer can meet the requirements.

To ensure transparency regarding the selection of materials or products used for NDOT/LPA projects, the Department will require a letter to the file, signed by the responsible Section Head (or project owner if and LPA), documenting why it's in the public interest for the Sole Source product to be specified. The letter should address whether there is a suitable alternative available and if the product is needed for synchronization. The letter must clearly substantiate the benefit of specifying the Sole Source product or material. The public interest justification may be completed on a program-wide basis for those Sole Sourced materials or products where the application is program-wide and where project specific public interest justification letters are not

Operating Instruction 60-19

feasible, programmatic justifications will cover the use of the material or product on all projects for a specified amount of time, not to exceed one year, before re-evaluation of the Sole Source justification must take place.

**6. NDOT or LPA Supplied Material**

Federal regulations regarding material or products supplied by NDOT or an LPA are covered under 23 CFR 635.407, and are not encompassed in the final rule change. This means that the approval process for **NDOT or LPA supplied material on Federal-aid products will require a Public Interest Finding (PIF)** substantiating that it's in the public interest to require the contractor to use materials furnished by, or sources designated for use by, the NDOT or LPA. Factors to justify a PIF could include such items as cost effectiveness, material lead times, system integrity, and local shortages of material. The PIF must be signed by the Deputy Director - Engineering or their designee.

When the use of NDOT or LPA furnished manufactured material is approved based on a PIF, such use must be made mandatory. Manufactured materials to be furnished by NDOT or LPA must have been acquired through competitive bidding.

When NDOT or LPA owns or controls a local natural materials source, such as a borrow pit or a stockpile of salvaged pavement material, etc., the materials may be designated for either optional or mandatory use (optional use does not require a PIF). The location, cost, and any conditions to be met for obtaining the materials that are made available to the contractor must be stated in the special provisions.

Projects that are not federally funded must adhere to the process above, except that the PIF should be in the form of a letter to the file with the signature of the responsible Section Head (or project owner if an LPA). Deputy Director – Engineering signature is not required when the project is not Federal-aid participating.

**7. The information above is not intended to be all-inclusive.** Unique situations will be handled as they arise. Please contact the Contracts Letting Manager if you have questions or need additional information regarding the subjects herein.

Moe Jamshidi, P.E.  
Deputy Director – Operations

**Subject: PUBLIC INTEREST LETTERS**

MEMORANDUM OF UNDERSTANDING

This MOU implements the provisions of 23CFR635.309(b), (c), (g) and (h) for State Highway Projects. The statements required in these paragraphs are contained in a document called the Right of Way certificate (certificate), and need to be prepared prior to any bid advertisement. The certificate will be certified by the Right of Way Division's Property Management Supervisor and will be approved by the Right of Way Division Manager.

The Monthly Project Scheduling Team is responsible for reviewing individual projects to determine if the provisions of (c)(3) are applicable. When the team decides that those provisions are applicable a letter will be prepared justifying why it is in the public's interest to proceed with advertising the project. The letter will be signed by the Roadway Design Engineer and will include a brief description of each un-acquired tract sufficient to form a reasonable conclusion of the significance of the tract.

The Deputy Director-Engineering will review the public interest letter and give consideration to the following factors in determining if advertising the project is in the public interest.

1. The proposed starting date of the contract
2. The feasibility of moving the project to another letting
3. The number and significance of the remaining un-acquired tracts
4. The exact status in the acquisition process of the un-acquired tracts
5. The overall justification of exactly why it is in the public interest to have the project in a particular letting.

On those projects not involving residential or business displacees still in occupancy the Deputy Director's decision will be final. No approval is required by the FHWA.

The Contracts Section of the Construction Division will provide an information copy of all ROW certificates and public interest letters to the FHWA prior to each letting.

If a Residential or business displacee is still in occupancy the above-described letter will be presented to the FHWA for approval.

ORIGINAL SIGNED BY:

\_\_\_\_\_  
Allan L. Abbott  
Director-State Engineer  
Nebraska Department of Transportation

\_\_\_\_\_  
Bruce Lind  
Division Administrator  
Federal Highway Administration

12/07/1998



U.S. Department of Transportation  
**Federal Highway Administration**  
1200 New Jersey Avenue, SE  
Washington, DC 20590  
202-366-4000

---

## Civil Rights

## Civil Rights



U.S. Department of Justice  
Civil Rights Division  
*Disability Rights Section*



U.S. Department of Transportation  
**Federal Highway Administration**

### **Department of Justice/Department of Transportation Joint Technical Assistance<sup>1</sup> on the Title II of the Americans with Disabilities Act Requirements to Provide Curb Ramps when Streets, Roads, or Highways are Altered through Resurfacing**

Title II of the Americans with Disabilities Act (ADA) requires that state and local governments ensure that persons with disabilities have access to the pedestrian routes in the public right of way. An important part of this requirement is the obligation whenever streets, roadways, or highways are *altered* to provide curb ramps where street level pedestrian walkways cross curbs.<sup>2</sup> This requirement is intended to ensure the accessibility and usability of the pedestrian walkway for persons with disabilities.

An alteration is a change that affects or could affect the usability of all or part of a building or facility.<sup>3</sup> Alterations of streets, roads, or highways include activities such as reconstruction, rehabilitation, *resurfacing*, widening, and projects of similar scale and effect.<sup>4</sup> Maintenance activities on streets, roads, or highways, such as filling potholes, are not alterations.

Without curb ramps, sidewalk travel in urban areas can be dangerous, difficult, or even impossible for people who use wheelchairs, scooters, and other mobility devices. Curb ramps allow people with mobility disabilities to gain access to the sidewalks and to pass through center islands in streets. Otherwise, these individuals are forced to travel in streets and roadways and are put in danger or are prevented from reaching their destination; some people with disabilities may simply choose not to take this risk and will not venture out of their homes or communities.

Because resurfacing of streets constitutes an alteration under the ADA, it triggers the obligation to provide curb ramps where pedestrian walkways intersect the resurfaced streets. See *Kinney v. Yerusalim*, 9 F 3d 1067 (3rd Cir. 1993). This obligation has been discussed in a variety of technical assistance materials published by the Department of Justice beginning in 1994.<sup>5</sup> Over the past few years, state and local governments have sought further guidance on the scope of the alterations

requirement with respect to the provision of curb ramps when streets, roads or highways are being resurfaced. These questions have arisen largely due to the development of a variety of road surface treatments other than traditional road resurfacing, which generally involved the addition of a new layer of asphalt. Public entities have asked the Department of Transportation and the Department of Justice to clarify whether particular road surface treatments fall within the ADA definition of alterations, or whether they should be considered maintenance that would not trigger the obligation to provide curb ramps. This Joint Technical Assistance addresses some of those questions.

#### **Where must curb ramps be provided?**

Generally, curb ramps are needed wherever a sidewalk or other pedestrian walkway crosses a curb. Curb ramps must be located to ensure a person with a mobility disability can travel from a sidewalk on one side of the street, over or through any curbs or traffic islands, to the sidewalk on the other side of the street. However, the ADA does not require installation of ramps or curb ramps in the absence of a pedestrian walkway with a prepared surface for pedestrian use. Nor are curb ramps required in the absence of a curb, elevation, or other barrier between the street and the walkway.

#### **When is resurfacing considered to be an alteration?**

Resurfacing is an alteration that triggers the requirement to add curb ramps if it involves work on a street or roadway spanning from one intersection to another, and includes overlays of additional material to the road surface, with or without milling. Examples include, but are not limited to the following treatments or their equivalents: addition of a new layer of asphalt, reconstruction, concrete pavement rehabilitation and reconstruction, open-graded surface course, micro-surfacing and thin lift overlays, cape seals, and in-place asphalt recycling.

#### **What kinds of treatments constitute maintenance rather than an alteration?**

Treatments that serve solely to seal and protect the road surface, improve friction, and control splash and spray are considered to be maintenance because they do not significantly affect the public's access to or usability of the road. Some examples of the types of treatments that would normally be considered maintenance are: painting or striping lanes, crack filling and sealing, surface sealing, chip seals, slurry seals, fog seals, scrub sealing, joint crack seals, joint repairs, dowel bar retrofit, spot high-friction treatments, diamond grinding, and pavement patching. In some cases, the combination of several maintenance treatments occurring at or near the same time may qualify as an alteration and would trigger the obligation to provide curb ramps.

#### **What if a locality is not resurfacing an entire block, but is resurfacing a crosswalk by itself?**

Crosswalks constitute distinct elements of the right-of-way intended to facilitate pedestrian traffic. Regardless of whether there is curb-to-curb resurfacing of the street or roadway in general, resurfacing of a crosswalk also requires the provision of curb ramps at that crosswalk.

---

<sup>1</sup> The Department of Justice is the federal agency with responsibility for issuing regulations implementing the requirements of title II of the ADA and for coordinating federal agency compliance activities with respect to those requirements. Title II applies to the programs and activities of state and local governmental entities. The Department of Justice and the Department of Transportation share responsibility for enforcing the requirements of title II of the ADA with respect to the public right of way, including streets, roads, and highways.

<sup>2</sup> See 28 CFR 35.151(i)(1) (Newly constructed or altered streets, roads, and highways must contain curb ramps or other sloped areas at any intersection having curbs or other barriers to entry from a street level pedestrian walkway) and 35.151(i)(2) (Newly constructed or altered street level pedestrian walkways must contain curb ramps or other sloped areas at intersections to streets, roads, or highways).

<sup>3</sup> 28 CFR 35.151(b)(1).

<sup>4</sup> 2010 ADA Accessibility Standards, section 106.5.

<sup>5</sup> See 1994 Title II Technical Assistance Manual Supplement, Title II TA Guidance: The ADA and City Governments: Common Problems; and ADA Best Practices Tool Kit for State and Local Governments: Chapter 6, Curb Ramps and Pedestrian Crossings under Title II of the ADA, available at [ada.gov](http://ada.gov).

Page last modified on October 25, 2018.

U.S. Department of Transportation  
**Federal Highway Administration**  
1200 New Jersey Avenue, SE  
Washington, DC 20590  
202-366-4000

---

## Civil Rights

## Civil Rights

### **Glossary of Terms for DOJ/FHWA Joint Technical Assistance on the ADA Title II Requirements to Provide Curb Ramps When Streets Roads or Highways are Altered Through Resurfacing**

This glossary is intended to help readers understand certain road treatments referenced on page 2 of the DOJ/FHWA Joint Technical Assistance on the ADA Title II Requirements to Provide Curb Ramps When Streets Roads or Highways are Altered Through Resurfacing. The definitions explain the meaning of these terms from an engineering perspective and are provided in the order in which they appear in the Technical Assistance document.

#### **Treatments that are considered alterations of the road surface**

**Reconstruction** – Reconstruction refers to removing all or a significant portion of the pavement material and replacing it with new or recycled materials. This may include full-depth reclamation, where the pavement surface is demolished in place and new pavement surface is applied. In addition, reconstruction may also include grinding up a portion of the pavement surface, recycling it and placing it back, and then adding a wearing surface, such as in cold in-place asphalt recycling. Reconstruction often includes widening or geometrical changes to the roadway profile.

**Rehabilitation** – Rehabilitation refers to significant repairs made to a road or highway surface, including activities such as full slab replacement, filling voids under slabs (slabjacking), widening, and adding additional structural capacity.

**Open-graded surface course** – Open-graded surface course, also known as “open-graded friction course,” involves a pavement surface course that consists of a high-void, asphalt concrete mix that permits rapid drainage of rainwater through the course and off the shoulder of the road. The mixture consists of either Polymer-modified or rubber-modified asphalt binder, a large percentage of one-sized coarse aggregate, and a small amount of fibers. This treatment prevents tires from hydroplaning and provides a skid-resistant pavement surface with significant noise reduction.

**Microsurfacing** – Microsurfacing involves spreading a properly proportioned mixture of polymer modified asphalt emulsion, mineral aggregate, mineral filler, water, and other additives, on a paved surface. Microsurfacing differs from slurry seal in that it can be used on high volume roadways to correct wheel path rutting and provide a skid resistant pavement surface.



**Thin lift overlays** – Thin lift overlays are thin applications of mixtures of hot mix asphalt. Thin lift overlays may also require some milling along curbs, manholes, existing curb cuts, or other road structures to assure proper drainage and cross slopes.

**Cape seal** – A cape seal is a thin surface treatment constructed by applying a slurry seal or microsurfacing to a newly constructed chip seal. It is designed to be an integrated system where the primary purpose of the slurry is to fill voids in the chip seal.

**In-place asphalt recycling** – In-place asphalt recycling is a process of heating and removing around 1-2 inches of existing asphalt and remixing the asphalt with the addition of a binder additive and possible aggregate to restore the wearing surface for placement and compaction. All of this is performed in a train of equipment.

#### **Treatments that are considered maintenance of the road surface**

**Crack filling and sealing** – Crack filling and sealing involves placing elastomeric material directly into cracks in pavement.

**Surface sealing** – Surface sealing involves applying liquid sealant to pavement surface in order to stop water penetration and/or reduce oxidation of asphalt products. Sand is sometimes spread over liquid to absorb excess material.

**Chip seals** – Chip Seals involve placing graded stone (chips) on liquid emulsified asphalt sprayed on pavement surface. The surface is rolled to enable seating of chips.

**Slurry seal** – Slurry seals involve spraying a mixture of slow setting emulsified asphalt, well graded fine aggregate, mineral filler, and water on the pavement surface. It is used to fill cracks and seal areas of old pavements, to restore a uniform surface texture, to seal the surface to prevent moisture and air intrusion into the pavement, and to improve skid resistance.

**Fog seals** – Fog seals are a type of surface sealing.

**Scrub sealing** – Scrub sealing is type of surface sealing

**Joint crack seals** – Joint crack seals are usually associated with concrete pavement. This work consists of routing and cleaning existing cracks and joints and resealing to prevent water and non-compressibles from entering into the pavement joints and subgrade materials.

**Joint repairs** – Joint repairs are usually associated with concrete pavement. This work consists of selectively repairing portions of the pavement where the slabs are generally in good condition, but corners or joints are broken. The depth of the patch could be full depth or partial depth.

**Dowel retrofit** – Dowel retrofits are usually associated with concrete pavement. This work involves the installation of dowel bars connecting slabs in existing pavements. Pavement with dowel bar retrofits can have life extensions of as much as 20 years. Its application is almost exclusively on high-speed Interstate highways.

**Spot high-friction treatments** – Spot high-friction treatments involve using epoxy based resin liquids as a binder for an aggregate with high-friction properties. These are used in locations where drivers are frequently braking and the pavement surface has less resistance to slipping.

**Diamond grinding** – Diamond grinding involves using a gang saw to cut grooves in the pavement surface to restore smoothness and eliminate any joint faulting.

**Pavement patching** – Pavement patching involves selectively repairing portions of the pavement where the slabs are generally in good condition, but corners or joints are broken. The depth of the patch could be full depth or partial depth.

Page last modified on October 25, 2018.

**UPGRADING RURAL INTERCHANGES  
ON I-80 IN NEBRASKA**

The following is a guide for upgrading I-80 interchange bridges and approaches in rural areas. These guidelines are based on economic analyses that compare the benefits derived from accident cost reduction to the cost of the improvement. This should be used for interchange projects and projects involving intersecting highways at an interchange.

1. Crossroads with a design year ADT of less than 3000:

- A. If the bridge width meets "Needs Study" criteria and the structural condition is sufficient to use in place, repair the bridge as needed. Upgrade the guardrail and bridge rail, use the existing gradeline in place, and upgrade the pavement surface as needed. Sign the roadway for reduced speed, if necessary.
- B. If the bridge width does not meet "Needs Study" criteria or if the bridge has major structural deficiencies, replace the bridge to "New and Reconstructed" standards. The clear roadway width on the new bridge must meet minimum design standards and should match the width of the approach roadway plus shoulders. The new bridge should be a two-span structure providing adequate lateral clearance for the outside travel lanes on I-80. Retaining walls should be considered where it is possible to use a shorter bridge length. Upgrade the guardrail.
- C. Use the existing gradeline in place if it meets "Needs Study" criteria (max. allowable speed for crest vertical curves: 40 mph below 400 ADT and 45 mph at and above 400 ADT) and upgrade the pavement surface as needed. Sign the roadway for reduced speed, if necessary.

2. Crossroads with a design year ADT of 3000 or greater:

- A. If the bridge width meets "Needs Study" criteria and the structural condition is sufficient to use in place, repair the bridge as needed. If the existing gradeline meets "Needs Study" criteria, use the gradeline in place, widen the roadway at the ramp terminals to provide left-turn lanes if justified by the Traffic Engineering Division, upgrade the pavement surface as needed, upgrade the guardrail, and sign the roadway for reduced speed, if necessary. Further study may be needed to determine if the bridge should be widened or replaced to accommodate left-turn-lane storage.
- B. If the bridge width does not meet "Needs Study" criteria or if the bridge has major structural deficiencies, replace the bridge to meet "New and Reconstructed" standards. The new bridge should be a two-span structure providing adequate lateral clearance for the outside travel lanes on I-80. Retaining walls should be considered where it is possible to use a shorter bridge length.
- C. Rebuild the crossroad if the existing vertical alignment does not meet "New and Reconstructed" standards. However, if the impact to adjacent property is significant, consider design features closer to minimum or lower design speeds. If the vertical alignment is sufficient, upgrade the pavement surface as needed.

ORIGINAL SIGNED BY:

Approved \_\_\_\_\_ Date: 6-19-96  
Monty W. Fredrickson  
Deputy Director – Engineering

SUPPLEMENT TO THE  
I-80 RURAL INTERCHANGE STUDY

This supplement describes the economic analyses that provide the guidelines contained in “**UPGRADING RURAL INTERCHANGES ON I-80 IN NEBRASKA**”. The information that helped develop the guidelines came from a 1995 study of rural I-80 interchanges.

## BACKGROUND

In Nebraska, I-80 was built between 1957 and 1974. Many of its rural interchanges have four-span bridges and vertical geometrics that do not meet modern “New and Reconstructed” standards.

The four-span bridges, typically, have piers located three to four meters from the edge of the driving lane of I-80. This does not meet the DR-1 lateral obstacle clearance of 11 meters. New two-span bridges provide the required lateral clearance.

Roadway approaches of the crossroad were originally designed to provide minimum stopping sight distances for 80 km/h (50 mph). Under modern criteria, many of these vertical alignments now have minimum stopping sight distances for only about 70 km/h (45 mph).

## ACCIDENTS

A review of accidents occurring during the five-year period from June 1989 to May 1994 revealed a significant increase in the number of accidents on the crossroad over I-80 when current ADT exceeds 2,500. Most of these accidents occurred near the ramp terminals where slowing, stopping, and turning maneuvers occur.

Interchanges where the crossroad carries less than 2,500 current ADT have less than one accident per year on the average. Major improvements, such as reconstruction of the gradeline, may not be cost effective since the potential for reducing accidents is low.

Because the current ADT of 2,500 appeared to be the dividing line for accidents, a design year ADT of 3,000 is used in the recommendations.

Some accidents may be attributed to sight distance. As stated above, many of these crossroads have only 70 km/h (45 mph) speeds for minimum stopping sight distance for crest vertical curves. Stopping sight distance at the ramp terminals will generally be higher for a passenger vehicle.

Sight distance for vehicles turning onto the crossroad from the ramp was evaluated. Vehicles on the crossroad would normally have to slow down to less than 85 percent of the mainline speed of 90 km/h (55 mph) when a passenger vehicle pulls out from a stop condition at the ramp terminal, turns either left or right, and proceeds. Sight distance requirements are met for a 90 km/h (55 mph) design speed to allow a passenger vehicle to turn left onto the crossroad and not interfere with a passenger vehicle approaching from the left.

Accidents on I-80 near interchanges are relatively few. Most occur at a grade separation, normally hitting the guardrail and occasionally the piers.

**GEOMETRIC DEFICIENCIES**

Three primary geometric deficiencies exist at many of the interchanges. First, there is the lateral obstacle clearance deficiency for through-traffic lanes on I-80 because of pier location. Second, there is a bridge width deficiency for the crossroad over I-80. Third, there is also less than a 90 km/h (55 mph) minimum sight distance on the crossroad. Replacing the bridge with a two-span structure which meets “New and Reconstructed” standards would correct the first of these deficiencies, but not the third.

A substantial investment went into constructing the I-80 interchanges and justification for correcting the current deficiencies should be based on an effective cost analysis. A benefit/cost analysis compares the reduction in accident costs derived from a safety improvement to the cost of the improvement.

Depending on the pavement history, the guardrail would normally be replaced three times (minimum) or four times (maximum) over a 50-year period. The benefit/cost analysis considers both possibilities.

**BRIDGE WIDTH**

For new or reconstructed bridges on state highways, the clear roadway width must meet minimum design standards and should match the width of the approach roadway plus shoulders. The width of most bridge approaches is 44’ (24’ roadway and 10’ shoulders).

**CALCULATIONS AND CONCLUSIONS**

1. If bridge widening is required, it is more cost effective to replace the existing four-span bridge with a two-span bridge that meets “New and Reconstructed” standards, than to widen and redeck the existing bridge.
  - A. Assuming an average bridge length of 235’ and a crossroad approach of 44’, the cost of widening and redecking an existing bridge to 46.4’ (44’ plus 2.4’ for width of rails) is \$501,584.
 
$$235' \times 46.4' \times \$46/\text{sf} = \$501,584$$
  - B. Assuming that the average bridge could be shortened by 35’ using retaining walls, the latter costing \$115,000, the cost of replacing an existing bridge with a new structure is \$642,104.
 
$$200' \times 46.4' \times \$56.80/\text{sf} = \$527,104$$

$$\$527,104 + \$115,000 = \$642,104$$
  - C. A life-cycle, 50-year, cost analysis of upgrading the guardrail three or four times to protect the outside piers of an existing four-span bridge indicates the following additional cost for widening an existing bridge. The costs of installation, maintenance, and accidents are included.

	Three Guardrail <u>Upgrades</u>	Four Guardrail <u>Upgrades</u>
Low volume traffic	\$130,170	\$148,175
Medium volume traffic	\$175,878	\$193,878
High volume traffic	\$218,196	\$236,196

Note: “Low volume traffic” refers to western I-80, Wyoming border to I-76 (5,800 ADT). “Medium volume traffic” refers to central I-80, I-76 to Grand Island (12,460 ADT). “High volume traffic” refers to eastern I-80, Grand Island to Seward (17,680 ADT).

D. Therefore, the total cost of widening and redecking an overpass bridge is:

Three Guardrail Upgrades

Low volume traffic	$\$501,584 + \$301,170 = \$631,754$
Medium volume traffic	$\$501,584 + \$175,878 = \$677,462$
High volume traffic	$\$501,584 + \$218,196 = \$719,780$

Four Guardrail Upgrades

Low volume traffic	$\$501,584 + \$148,175 = \$649,759$
Medium volume traffic	$\$501,584 + \$193,878 = \$695,462$
High volume traffic	$\$501,584 + \$236,196 = \$737,780$

- E. Comparing the cost to replace an overpass bridge (\$642,104) to the figures in paragraph D above, it is more cost effective to replace a bridge than to widen and redeck it. Note that for low volume, three guardrail upgrades, the life-cycle cost is slightly less than the cost of replacement. The difference is less than two percent and, therefore, is considered adequate justification for replacement.
2. Along I-80, it is cost effective to remove the outside guardrail at pier locations and provide adequate lateral obstacle clearance. This is true for both low-volume and high-volume traffic sections. The clearance would be provided if the four-span bridges were replaced with two-span bridges. For two-span bridges, the center pier still requires guardrail. This conclusion supplements the cost effectiveness of paragraph one above.
  3. On low-volume crossroads (under 3,000 design year ADT), it is not cost effective to build short left-turn lanes between the ramp terminals and the overpass bridge. The cost to add short left-turn lanes at the ramp terminals is about \$180,000. Evaluating the accident report information indicated that there are very few cases where a separate left-turn lane would have prevented the accident. However, for design year ADT's exceeding 3,000, accidents prevented using left-turn lanes may actually be cost effective where sight distance is restricted.

## SURVEY/PLAN ACCURACY

<u>DESCRIPTION</u>	<u>(feet)</u>
<b>Alignment</b> (PI's, PC's, PT's, equations Project Stationing) Begin/End of Project	0.01 1
<b>Farmstead Drives</b> (Stationing)	1
<b>Field Entrances</b> (Stationing)	1
<b>County Roads</b> (Stationing) Build note to the nearest foot	0.1 1
<b>Intersecting Hwy/Streets</b> (Stationing) Build note to the nearest foot	0.1 1
<b>Tel Poles/Power Poles</b> (Sta./Offset)	1
<b>Drainage Pipes</b> (Stationing)	1
(Length of Pipe)	1
(Skew Angle)	Nearest Degree
(Flow Line Elevation)	0.01
<b>Drainage Box Culverts</b> (Stationing)	1
Build Note to the nearest foot	1
(Length of Box)	0.1
(Skew Angle)	Nearest Degree
(Flow Line Elevation)	0.01
<b>Bridges</b> (Stationing & Approach Slabs)	0.01
Paving Sections	Even foot from end of Bridge
Bridge Exceptions for Typ. Sections	1
(Example: Approach & Paving Sections are built from Sta. 103 + 10.56 to 110 + 42.21, The exception is from Sta. 103 + 10 to 110 + 43)	
<b>Wells</b> (Stationing/Offset)	1
<b>ROW Markers</b> (Coordinate Survey)	Not Required
<b>Control Points</b> (Coordinate Survey) (Surveyed by Station & Offset)	Not Required 0.01
<b>Bench Marks</b> (Coordinate Survey) (Surveyed by Station & Offset)	Not Required 0.01
<b>Hard Surface Grades</b>	0.01
(Top of Curb)	0.01
<b>Build Notes</b> (Stationing & Offset)	1
<b>Cross-Sections</b> (Everything, including Culvert Cross-Sections)	1





Degree	Radius (ft.)	Degree	Radius (ft.)	Degree	Radius (ft.)
0° 15'	22,918.312	8° 15'	694.494	16° 15'	352.589
0° 30'	11,459.156	8° 30'	674.068	16° 30'	347.247
0° 45'	7639.437	8° 45'	654.809	16° 45'	342.064
1° 00'	5729.578	9° 00'	636.620	17° 00'	337.034
1° 15'	4583.662	9° 15'	619.414	17° 15'	332.149
1° 30'	3819.719	9° 30'	603.113	17° 30'	327.404
1° 45'	3274.045	9° 45'	587.649	17° 45'	322.793
2° 00'	2864.789	10° 00'	572.958	18° 00'	318.310
2° 15'	2546.479	10° 15'	558.983	18° 15'	313.549
2° 30'	2291.831	10° 30'	545.674	18° 30'	309.707
2° 45'	2083.483	10° 45'	532.984	18° 45'	305.577
3° 00'	1909.859	11° 00'	520.871	19° 00'	301.557
3° 15'	1762.947	11° 15'	509.296	19° 15'	297.640
3° 30'	1637.022	11° 30'	498.224	19° 30'	293.825
3° 45'	1527.887	11° 45'	487.624	19° 45'	290.105
4° 00'	1432.394	12° 00'	477.465	20° 00'	286.479
4° 15'	1348.136	12° 15'	467.721	20° 30'	279.492
4° 30'	1273.240	12° 30'	458.366	21° 00'	272.837
4° 45'	1206.227	12° 45'	449.379	21° 30'	266.492
5° 00'	1145.916	13° 00'	440.737	22° 00'	260.435
5° 15'	1091.348	13° 15'	432.421	22° 30'	254.648
5° 30'	1041.741	13° 30'	424.413	23° 00'	249.112
5° 45'	996.448	13° 45'	416.697	23° 30'	243.812
6° 00'	954.930	14° 00'	409.256	24° 00'	238.732
6° 15'	916.732	14° 15'	402.076	24° 30'	233.860
6° 30'	881.474	14° 30'	395.143	25° 00'	229.183
6° 45'	848.826	14° 45'	388.446	25° 30'	224.689
7° 00'	818.511	15° 00'	381.972	26° 00'	220.368
7° 15'	790.287	15° 15'	375.710	26° 30'	216.210
7° 30'	763.944	15° 30'	369.650	27° 00'	212.207
7° 45'	739.300	15° 45'	363.783	27° 30'	208.348
8° 00'	716.197	16° 00'	358.099	28° 00'	204.628

Degree of Curve = 5729.578 ÷ Radius



Appendix H presents guidance for the design of new and reconstructed projects.

## AASHTO MINIMUM DESIGN GUIDANCE

### SOURCES

1. American Association of State Highway and Transportation Officials, A Policy on Geometric Design of Highways and Streets (*Green Book*), Washington, D.C., 2018.
2. American Association of State Highway and Transportation Officials, A Policy on Design Standards Interstate System (*I-State Green Book*), Washington, D.C., 2016.
3. American Association of State Highway and Transportation Officials, Roadside Design Guide, Washington, D.C., 2011.

### DEFINITIONS

The following definitions are from A Policy on Geometric Design of Highways and Streets (2018)

- **Rural Context:** “The rural context applies to roads in rural areas that are not within a developed community. These include areas with the lowest development density; few houses or structures; widely dispersed or no residential, commercial, and industrial land uses; and usually large building setbacks. The rural context may include undeveloped land, farms, outdoor recreation areas, or low densities of other types of development. Most roads in rural areas fit the rural context and should be designed in a manner similar to past design criteria for rural facilities.”
- **Rural Town Context:** “The rural town context applies to roads in rural areas located within developed communities. Rural towns generally have low development densities with diverse land uses, on-street parking, and sidewalks in some locations, and small building setbacks. Rural towns may include residential neighborhoods, schools, industrial facilities, and commercial main street business districts, each of which present differing design challenges and differing levels of pedestrian and bicycle activity. The rural town context recognizes that rural highways change character where they enter a small town, or other rural community, and that design should meet the needs of not only through travelers, but also the residents of the community. Speed expectations of through travelers change when they enter a rural town.”

- **Suburban Context:** “The suburban context applies to roads and streets, typically within the outlying portions of urban areas, with low to medium development density, mixed land uses (with single-family residences, some multi-family residential structures, and nonresidential development including mixed town centers, commercial corridors, big box commercial stores, light industrial development). Building setbacks are varied with mostly off-street parking. The suburban context generally has lower development densities and drivers have higher speed expectations than the urban and urban core contexts. Pedestrians and bicyclist flows are higher than in the rural context, but may not be as high as found in urban and urban core areas.”
- **Urban Context:** “The urban context has high-density development, mixed land uses, and prominent destinations. On-street parking and sidewalks are generally more common than in the suburban context, and building setbacks are mixed. Urban locations often include multi-story and low- to medium-rise structures for residential, commercial, and educational uses. Many structures accommodate mixed uses: commercial, residential, and parking. The urban context includes light industrial, and sometimes heavy industrial, land use. The urban context also includes prominent destinations with specialized structures for entertainment, including athletic and social events, as well as conference centers. In small- and medium-sized communities, the central business district may be more an urban context than an urban core context. Driver speed expectations are generally lower and pedestrian and bicyclist flows higher than in suburban areas. The density of transit routes is generally greater in the urban context than the suburban context, including in-street rail transit in larger communities and transit terminals in small- and medium-sized communities.”
- **Urban Core Context:** “The urban core context includes areas of the highest density, with mixed land uses within and among predominantly high-rise structures, and with small building setbacks. The urban core context is found predominantly in the central business districts and adjoining portions of major metropolitan areas. On-street parking is often more limited and time restricted than in the urban context. Substantial parking is in multi-level structures attached to or integrated with other structures. The area is accessible to automobiles, commercial delivery vehicles, and public transit. Sidewalks are present nearly continuously, with pedestrian plazas and multi-level pedestrian bridges connecting commercial and parking structures in some locations. Transit corridors, including bus and rail transit, are typically common and major transit terminals may be present. Some government services are available, while other commercial uses predominate, including financial and legal services. Structures may have multiple uses and setbacks are not as generous as in the surrounding urban area. Residences are often apartments or condominiums. Driver speed expectations are low and pedestrian and bicycle flows are high.”

**AASHTO MINIMUM DESIGN GUIDANCE**  
AASHTO CLASSIFICATION/STATE FUNCTIONAL CLASSIFICATION  
[NATIONAL FUNCTIONAL CLASSIFICATION]

**NEW AND RECONSTRUCTED RURAL PROJECTS**

Interstate/Interstate	
[Principal Arterial – Interstate].....	H-5
Rural Freeway/Expressway (Access Only at Interchanges)	
[Principal Arterial - Other Freeways & Expressways] .....	H-6
Rural Divided Arterial/Expressway	
[Principal Arterial - Other Freeways & Expressways] .....	H-7
Rural Town Divided Arterial/Expressway	
[Principal Arterial - Other Freeways & Expressways] .....	H-8
Rural Arterial/Major Arterial	
[Arterial] .....	H-9
Rural Town Arterial/Major Arterial	
[Arterial] .....	H-10
Rural Collector/Major Arterial	
[Collector/Local].....	H-11
Rural Town Collector/Major Arterial	
[Collector/Local].....	H-12
Recreational Roads/Major Arterial – Scenic Recreation	
[Collector/Local].....	H-13

**NEW AND RECONSTRUCTED MUNICIPAL PROJECTS**

Interstate/Interstate	
[Principal Arterial – Interstate].....	H-14
Suburban Freeway/Expressway (Access Only at Interchanges)	
[Principal Arterial – Other Freeways & Expressways] .....	H-15
Urban Freeway/Expressway (Access Only at Interchanges)	
[Principal Arterial – Other Freeways & Expressways] .....	H-16
Urban Core Freeway/Expressway (Access Only at Interchanges)	
[Principal Arterial – Other Freeways & Expressways] .....	H-17
Suburban Arterial/Expressway	
[Principal Arterial – Other Freeways & Expressways] .....	H-18
Urban Arterial/Expressway	
[Principal Arterial – Other Freeways & Expressways] .....	H-19
Urban Core Arterial/Expressway	
[Principal Arterial – Other Freeways & Expressways] .....	H-20
Suburban Arterial/Major Arterial	
[Arterial] .....	H-21
Urban Arterial/Major Arterial	
[Arterial] .....	H-22
Urban Core Arterial/Major Arterial	
[Arterial] .....	H-23
Suburban Collector/Major Arterial	
[Collector] .....	H-24
Urban Collector/Major Arterial	
[Collector] .....	H-25
Urban Core Collector/Major Arterial	
[Collector] .....	H-26

**ROADSIDE DESIGN GUIDE EXHIBITS**

Table 3-1	Suggested Clear-Zone Distances in Feet from Edge of Through Traveled Lane .....	H-27
Figure 3-2	Clear Zone for Non-Recoverable Parallel Foreslope .....	H-28

**EXHIBITS**

Exhibit H.1	Design Criteria Dependent on Speed – New and Reconstructed Projects .....	H-29
Exhibit H.2	Maximum Allowable Grades – New and Reconstructed Rural Projects .....	H-30
Exhibit H.3	Maximum Allowable Grades – New and Reconstructed Municipal Projects .....	H-31

<b>NEW AND RECONSTRUCTED RURAL STATE HIGHWAYS</b>	
<b>AASHTO CLASSIFICATION: INTERSTATE</b>	
<b>STATE FUNCTIONAL CLASSIFICATION: INTERSTATE</b>	
<b>NATIONAL FUNCTIONAL CLASSIFICATION: PRINCIPAL ARTERIAL – INTERSTATE</b>	
<b>Design Speed</b>	70 mph
<b>Lane Width</b>	12 ft.
<b>Shoulder Width</b>	Right = 10 ft. 4-Lane (2 lanes in each direction): Left = 4 ft. Truck Traffic > 250 DDHV: Right = 12 ft. should be considered ≥ 6-Lane (≥ 3 lanes in each direction): Left = 10 ft. Truck Traffic > 250 DDHV: Right & Left = 12 ft. should be considered (Note: All shoulder widths are paved).
<b>Horizontal Alignment</b>	
<b>Superelevation</b>	$e_{max} = 8\%$
<b>*Minimum Radius (Based on Maximum Superelevation)</b>	1,810 ft.
<b>Vertical Alignment</b>	
<b>*Crest K Value</b>	247
<b>*Sag K Value</b>	181
<b>*Maximum Grade</b>	3% Level 4% Rolling
<b>*Stopping Sight Distance</b>	730 ft.
<b>Cross Slope</b>	
<b>Lane</b>	1.5% (A)
<b>Shoulder</b>	2% to 6% paved (B)
<b>Lateral Offset to Obstruction</b>	The nominal shoulder width.
<b>Vertical Clearance (1)</b>	Structure: 16 ft. Sign trusses and pedestrian/bicycle overpass: 17 ft.
<b>Bridge Width</b>	Full width of the approach roadway including paved shoulders. (D)
<b>Structural Capacity</b>	HL93

For additional information, see [A Policy on Design Standards Interstate System, May 2016](#) and [A Policy on Geometric Design of Highways and Streets, 2018](#)

\* The minimum value is based on the design speed; see Exhibits H.1, H.2, and H.3

- (1) Over the entire roadway width, including auxiliary lanes, shoulders, ramps, and collector-distributor roads.
- (A) On roadways where there are more than two lanes inclined in the same direction, the cross slope may be increased by 0.5% to 1% for each additional lane, up to a maximum of 3%.
- (B) The surfaced shoulder cross slope should not be less than the cross slope of the adjacent lane.
- (D) Long bridges (longer than 200 ft.) may have a lesser width and should be analyzed individually. On long bridges a reduced shoulder width of 4 ft. may be used on both the left and right sides.

<b>NEW AND RECONSTRUCTED RURAL STATE HIGHWAYS</b>	
<b>AASHTO CLASSIFICATION: RURAL FREEWAY</b>	
<b>STATE FUNCTIONAL CLASSIFICATION: EXPRESSWAY (ACCESS ONLY AT INTERCHANGES)</b>	
<b>NATIONAL FUNCTIONAL CLASSIFICATION: PRINCIPAL ARTERIAL – OTHER FREEWAYS AND EXPRESSWAYS</b>	
<b>Design Speed</b>	50 mph
<b>Lane Width</b>	12 ft.
<b>Shoulder Width</b>	Right = 10 ft. 4-Lane (2 lanes in each direction): Left = 4 ft. Truck Traffic > 250 DDHV: Right = 12 ft. should be considered ≥ 6-Lane (≥ 3 lanes in each direction): Left = 10 ft. Truck Traffic > 250 DDHV: Right & Left = 12 ft. should be considered (Note: All shoulder widths are paved).
<b>Horizontal Alignment</b>	
<b>Superelevation</b>	$e_{max} = 8\%$
<b>*Minimum Radius (Based on Maximum Superelevation)</b>	758 ft.
<b>Vertical Alignment</b>	
<b>*Crest K Value</b>	84
<b>*Sag K Value</b>	96
<b>*Maximum Grade</b>	4% Level 5% Rolling
<b>*Stopping Sight Distance</b>	425 ft.
<b>Cross Slope</b>	
<b>Lane</b>	1.5% to 2% (A)
<b>Shoulder</b>	2% to 6% paved (C)
<b>Lateral Offset to Obstruction</b>	The nominal shoulder width.
<b>Vertical Clearance (2)</b>	Structure: 16 ft. Sign trusses and pedestrian/bicycle overpass: Structure clearance + 1 ft.
<b>Bridge Width</b>	Full width of the approach roadway. (E)
<b>Structural Capacity</b>	HL93

For additional information, see [A Policy on Geometric Design of Highways and Streets](#), 2018

\* The minimum value is based on the design speed; see Exhibits H.1, H.2, and H.3

(2) Over the entire roadway width, including auxiliary lanes, shoulders, and collector-distributor roads.

(A) On roadways where there are more than two lanes inclined in the same direction, the cross slope may be increased by 0.5% to 1% for each additional lane, up to a maximum of 3%.

(C) The surfaced shoulder cross slope should not be less than the cross slope of the adjacent roadway lane and can be at least 1% greater.

(E) Bridges longer than 200 ft. may have a lesser width and should be analyzed individually.



<b>NEW AND RECONSTRUCTED RURAL STATE HIGHWAYS</b>	
<b>AASHTO CLASSIFICATION: RURAL DIVIDED ARTERIAL</b>	
<b>STATE FUNCTIONAL CLASSIFICATION: EXPRESSWAY</b>	
<b>NATIONAL FUNCTIONAL CLASSIFICATION: PRINCIPAL ARTERIAL</b>	
<b>Design Speed</b>	50 mph
<b>Lane Width</b>	12 ft. (11 ft. may be retained based on alignment and crash history)
<b>Shoulder Width</b>	8 ft. Right usable (paved is preferred, 4 ft. min. paved if used for bicycles) 4 ft. Left (paved) ≥ 6 Lane (≥ 3 lanes in each direction): Left = 8 ft.
<b>Horizontal Alignment</b>	
<b>Superelevation</b>	$e_{max} = 8\%$
<b>*Minimum Radius (Based on Maximum Superelevation)</b>	758 ft.
<b>Vertical Alignment</b>	
<b>*Crest K Value</b>	84
<b>*Sag K Value</b>	96
<b>*Maximum Grade (4)</b>	4% Level 5% Rolling
<b>*Stopping Sight Distance</b>	425 ft.
<b>Cross Slope</b>	
<b>Lane</b>	1.5% to 2% (A)
<b>Shoulder</b>	2% to 6% paved (B) 6% to 8% turf
<b>Lateral Offset to Obstruction</b>	The greater of the shoulder width or 4 ft. from the edge of the travelled way.
<b>Vertical Clearance (3)</b>	Structure: 16 ft. (14 ft. may be retained if allowed by local statute). Sign trusses and pedestrian/bicycle overpass: Structure clearance +1 ft.
<b>Bridge Width</b>	Full width of the approach roadway including shoulders and pedestrian/bicycle facilities. Bridge L > 200 ft. without pedestrian facilities and with infrequent bicycle use: Shoulder width shall be at least 4 ft.
<b>Structural Capacity</b>	HL93

For additional information, see [A Policy on Geometric Design of Highways and Streets](#), 2018

\* The minimum value is based on the design speed; see Exhibits H.1, H.2, and H.3

(3) Over the entire roadway width, including the usable width of the shoulders.

(4) Grade may be up to 1% steeper for tangent length less than 500 ft.

(A) On roadways where there are more than two lanes inclined in the same direction, the cross slope may be increased by 0.5% to 1% for each additional lane, up to a maximum of 3%.

(B) The surfaced shoulder cross slope should not be less than the cross slope of the adjacent lane.

<b>NEW AND RECONSTRUCTED RURAL STATE HIGHWAYS</b>	
<b>AASHTO CLASSIFICATION: RURAL TOWN DIVIDED ARTERIAL</b>	
<b>STATE FUNCTIONAL CLASSIFICATION: EXPRESSWAY</b>	
<b>NATIONAL FUNCTIONAL CLASSIFICATION: PRINCIPAL ARTERIAL</b>	
<b>Design Speed</b>	20 mph
<b>Lane Width</b>	10 ft.
<b>Shoulder Width</b>	8 ft. Right usable (paved is preferred, 4 ft. min. paved if used for bicycles) 4 ft. Left (paved) ≥ 6 Lane (≥ 3 lanes in each direction): Left = 8 ft.
<b>Horizontal Alignment</b>	
<b>Superelevation</b>	$e_{max} = 8\%$
<b>*Minimum Radius (Based on Maximum Superelevation)</b>	76 ft.
<b>Vertical Alignment</b>	
<b>*Crest K Value</b>	7
<b>*Sag K Value</b>	17
<b>*Maximum Grade (4)</b>	5% Level 8% Rolling
<b>*Stopping Sight Distance</b>	115 ft.
<b>Cross Slope</b>	
<b>Lane</b>	1.5% to 2% (A)
<b>Shoulder</b>	2% to 6% paved (B) 6% to 8% turf
<b>Lateral Offset to Obstruction</b>	The greater of the shoulder width or 4 ft. from the edge of the travelled way.
<b>Vertical Clearance (3)</b>	Structure: 16 ft. (14 ft. may be retained if allowed by local statute). Sign trusses and pedestrian/bicycle overpass: Structure clearance +1 ft.
<b>Bridge Width</b>	Full width of the approach roadway including shoulders and pedestrian/bicycle facilities. Bridge L > 200 ft. without pedestrian facilities and with infrequent bicycle use: Shoulder width shall be at least 4 ft.
<b>Structural Capacity</b>	HL93

For additional information, see [A Policy on Geometric Design of Highways and Streets](#), 2018

\* The minimum value is based on the design speed; see Exhibits H.1, H.2, and H.3

(3) Over the entire roadway width, including the usable width of shoulders.

(4) Grade may be up to 1% steeper for tangent length less than 500 ft.

(A) On roadways where there are more than two lanes inclined in the same direction, the cross slope may be increased by 0.5% to 1% for each additional lane, up to a maximum of 3%.

(B) The surfaced shoulder cross slope should not be less than the cross slope of the adjacent lane.

<b>NEW AND RECONSTRUCTED RURAL STATE HIGHWAYS</b>	
<b>AASHTO CLASSIFICATION: RURAL ARTERIAL</b>	
<b>STATE FUNCTIONAL CLASSIFICATION: MAJOR ARTERIAL</b>	
<b>NATIONAL FUNCTIONAL CLASSIFICATION: ARTERIAL</b>	
<b>Design Speed</b>	50 mph
<b>Lane Width</b>	ADT > 2,000 VPD: 12 ft. (11 ft. may be retained based on alignment & crash history) ADT ≤ 2,000 VPD: 11 ft.
<b>Shoulder Width</b>	ADT > 2,000 VPD: 8 ft. usable (paved is preferred) ADT 400 – 2,000 VPD: 6 ft. usable (paved is preferred) ADT < 400 VPD: 4 ft. usable (paved is preferred) (All shoulders - 4 ft. minimum should be paved if used for bicycles, a minimum of 2 ft. may be paved if low volumes and no bicycle use)
<b>Horizontal Alignment</b>	
<b>Superelevation</b>	$e_{max} = 8\%$
<b>*Minimum Radius (Based on Maximum Superelevation)</b>	758 ft.
<b>Vertical Alignment</b>	
<b>*Crest K Value</b>	84
<b>*Sag K Value</b>	96
<b>*Maximum Grade (4)</b>	4% Level 5% Rolling
<b>*Stopping Sight Distance</b>	425 ft.
<b>Cross Slope</b>	
<b>Lane</b>	1.5% to 2% (A)
<b>Shoulder</b>	2% to 6% paved (B) 6% to 8% turf
<b>Lateral Offset to Obstruction</b>	The greater of the shoulder width or 4 ft. from the edge of the travelled way.
<b>Vertical Clearance (3)</b>	Structure: 16 ft. (14 ft. may be retained if allowed by local statute). Sign trusses and pedestrian/bicycle overpass: Structure clearance + 1 ft.
<b>Bridge Width</b>	Full width of the approach roadway including shoulders and pedestrian/bicycle facilities. Bridge L > 200 ft. without pedestrian facilities and with infrequent bicycle use: Shoulder width shall be at least 4 ft.
<b>Structural Capacity</b>	HL93

For additional information, see [A Policy on Geometric Design of Highways and Streets, 2018](#)

\* The minimum value is based on the design speed; see Exhibits H.1, H.2, and H.3

- (3) Over the entire roadway width, including the usable width of shoulders.
- (4) Grade may be up to 1% steeper for tangent length less than 500 ft.
- (A) On roadways where there are more than two lanes inclined in the same direction, the cross slope may be increased by 0.5% to 1% for each additional lane, up to a maximum of 3%.
- (B) The surfaced shoulder cross slope should not be less than the cross slope of the adjacent lane.

<b>NEW AND RECONSTRUCTED RURAL STATE HIGHWAYS</b>	
<b>AASHTO CLASSIFICATION: RURAL TOWN ARTERIAL STATE FUNCTIONAL CLASSIFICATION: MAJOR ARTERIAL NATIONAL FUNCTIONAL CLASSIFICATION: ARTERIAL</b>	
<b>Design Speed</b>	20 mph
<b>Lane Width</b>	≤ 45 mph: 11 ft. ≥ 50 mph: 12 ft.
<b>Shoulder Width</b>	ADT > 2,000 VPD: 8 ft. usable (paved is preferred) ADT 400 – 2,000 VPD: 6 ft. usable (paved is preferred) ADT < 400 VPD: 4 ft. usable (paved is preferred) (All shoulders - 4 ft. minimum should be paved if used for bicycles, a minimum of 2 ft. may be paved if low volumes and no bicycle use)
<b>Horizontal Alignment</b>	
<b>Superelevation</b>	$e_{max} = 8\%$
<b>*Minimum Radius (Based on Maximum Superelevation)</b>	76 ft.
<b>Vertical Alignment</b>	
<b>*Crest K Value</b>	7
<b>*Sag K Value</b>	17
<b>*Maximum Grade (4)</b>	5% Level 8% Rolling
<b>*Stopping Sight Distance</b>	115 ft.
<b>Cross Slope</b>	
<b>Lane</b>	1.5% to 2% (A)
<b>Shoulder</b>	2% to 6% paved (B) 6% to 8% turf
<b>Lateral Offset to Obstruction</b>	The greater of the shoulder width or 4 ft. from the edge of the travelled way.
<b>Vertical Clearance (3)</b>	Structure: 16 ft. (14 ft. may be retained if allowed by local statute). Sign trusses and pedestrian/bicycle overpass: Structure clearance + 1 ft.
<b>Bridge Width</b>	Full width of the approach roadway including shoulders and pedestrian/bicycle facilities. Bridge L > 200 ft. without pedestrian facilities and with infrequent bicycle use: Shoulder width shall be at least 4 ft.
<b>Structural Capacity</b>	HL93

For additional information, see [A Policy on Geometric Design of Highways and Streets](#), 2018

\* The minimum value is based on the design speed; see Exhibits H.1, H.2, and H.3

- (3) Over the entire roadway width, including the usable width of shoulders.
- (4) Grade may be up to 1% steeper for tangent length less than 500 ft.
- (A) On roadways where there are more than two lanes inclined in the same direction, the cross slope may be increased by 0.5% to 1% for each additional lane, up to a maximum of 3%.
- (B) The surfaced shoulder cross slope should not be less than the cross slope of the adjacent lane.

<b>NEW AND RECONSTRUCTED RURAL STATE HIGHWAYS</b>			
<b>AASHTO CLASSIFICATION: RURAL COLLECTOR</b>			
<b>STATE FUNCTIONAL CLASSIFICATION: MAJOR ARTERIAL</b>			
<b>NATIONAL FUNCTIONAL CLASSIFICATION: COLLECTOR/LOCAL</b>			
	<b>ADT &gt; 2,000</b>	<b>ADT 400 – 2,000</b>	<b>ADT &lt; 400</b>
<b>Design Speed</b>	50 mph	40 mph	30 mph
<b>Lane Width</b>	11 ft. (6)	11 ft.	10 ft. (7)
<b>Shoulder Width</b>	6 ft.	4 ft.	2 ft.
<b>Horizontal Alignment</b>			
<b>Superelevation</b>	$e_{max} = 8\%$	$e_{max} = 8\%$	$e_{max} = 8\%$
<b>*Minimum Radius (Based on Max. Superelevation)</b>	758 ft.	444 ft.	214 ft.
<b>Vertical Alignment</b>			
<b>*Crest K Value</b>	84	44	19
<b>*Sag K Value</b>	96	64	37
<b>*Maximum Grade</b>	6% Level (4) 7% Rolling (4)	7% Level (5) 8% Rolling (5)	7% Level (5) 9% Rolling (5)
<b>*Stopping Sight Distance</b>	425 ft.	305 ft.	200 ft.
<b>Cross Slope</b>			
<b>Lane</b>	1.5% - 2%	1.5% - 2%	1.5% - 2%
<b>Shoulder</b>	2% - 6% paved (B) 6% - 8% turf	2% - 6% paved (B) 6% - 8% turf	2% - 6% paved (B) 6% - 8% turf
<b>Lateral Offset to Obstruction</b>	1.5 ft. from the edge of the travelled way (the greater of the shoulder width or 4 ft. is desirable).	1.5 ft. from the edge of the travelled way (the greater of the shoulder width or 4 ft. is desirable).	1.5 ft. from the edge of the travelled way (the greater of the shoulder width or 4 ft. is desirable).
<b>Vertical Clearance (3)</b>	Structure: 14 ft. Sign trusses and pedestrian/bicycle overpass: Structure clearance + 1 ft.	Structure: 14 ft. Sign trusses and pedestrian/bicycle overpass: Structure clearance + 1 ft.	Structure: 14 ft. Sign trusses and pedestrian/bicycle overpass: Structure clearance + 1 ft.
<b>Bridge Width</b>	Full width of the approach roadway plus surfaced shoulder width. Bridge L > 100 ft.: Traveled way + 3 ft. on each side.	Traveled way + 4 ft. on each side. Bridge L > 100 ft.: Traveled way + 3 ft. on each side.	Traveled way + 2 ft. on each side.
<b>Structural Capacity</b>	HL93	HL93	HL93

For additional information, see [A Policy on Geometric Design of Highways and Streets](#), 2018

\* The minimum value is based on the design speed; see Exhibits H.1, H.2, and H.3

- (3) Over the entire roadway width with an additional allowance for future resurfacing.
- (4) Grade may be up to 1% steeper for tangent length less than 500 ft.
- (5) For an AADT less than 2,000 vehicles/day, the grade may be up to 2% steeper for tangent length less than 500 ft.
- (6) Consider 12 ft. lanes for design speed  $\geq$  55 mph where substantial truck volumes are present or agricultural equipment frequently uses the road.
- (7) 9 ft. may be used for design speeds  $\leq$  40 mph with ADTs < 250 veh/day.
- (B) The surfaced shoulder cross slope should not be less than the cross slope of the adjacent lane.

<b>NEW AND RECONSTRUCTED RURAL STATE HIGHWAYS</b>			
<b>AASHTO CLASSIFICATION: RURAL TOWN COLLECTOR</b>			
<b>STATE FUNCTIONAL CLASSIFICATION: MAJOR ARTERIAL</b>			
<b>NATIONAL FUNCTIONAL CLASSIFICATION: COLLECTOR/LOCAL</b>			
	<b>ADT &gt; 2,000</b>	<b>ADT 400 – 2,000</b>	<b>ADT &lt; 400</b>
<b>Design Speed</b>	45 mph	40 mph	30 mph
<b>Lane Width</b>	11 ft. (6)	11 ft.	10 ft. (7)
<b>Shoulder Width</b>	6 ft.	4 ft.	2 ft.
<b>Horizontal Alignment</b>			
<b>Superelevation</b>	$e_{max} = 8\%$	$e_{max} = 8\%$	$e_{max} = 8\%$
<b>*Minimum Radius (Based on Max. Superelevation)</b>	587 ft.	444 ft.	214 ft.
<b>Vertical Alignment</b>			
<b>*Crest K Value</b>	61	44	19
<b>*Sag K Value</b>	79	64	37
<b>*Maximum Grade</b>	7% Level (4) 8% Rolling (4)	7% Level (5) 8% Rolling (5)	7% Level (5) 9% Rolling (5)
<b>*Stopping Sight Distance</b>	360 ft.	305 ft.	200 ft.
<b>Cross Slope</b>			
<b>Lane</b>	1.5% - 2%	1.5% - 2%	1.5% - 2%
<b>Shoulder</b>	2% - 6% paved (B) 6% - 8% turf	2% - 6% paved (B) 6% - 8% turf	2% - 6% paved (B) 6% - 8% turf
<b>Lateral Offset to Obstruction</b>	1.5 ft. from the edge of the travelled way (the greater of the shoulder width or 4 ft. is desirable).	1.5 ft. from the edge of the travelled way (the greater of the shoulder width or 4 ft. is desirable).	1.5 ft. from the edge of the travelled way (the greater of the shoulder width or 4 ft. is desirable).
<b>Vertical Clearance (3)</b>	Structure: 14 ft. Sign trusses and pedestrian/bicycle overpass: Structure clearance + 1 ft.	Structure: 14 ft. Sign trusses and pedestrian/bicycle overpass: Structure clearance + 1 ft.	Structure: 14 ft. Sign trusses and pedestrian/bicycle overpass: Structure clearance + 1 ft.
<b>Bridge Width</b>	Full width of the approach roadway plus surfaced shoulder width. Bridge L > 100 ft.: Traveled way + 3 ft. on each side.	Traveled way + 4 ft. on each side. Bridge L > 100 ft.: Traveled way + 3 ft. on each side.	Traveled way + 2 ft. on each side.
<b>Structural Capacity</b>	HL93	HL93	HL93

For additional information, see [A Policy on Geometric Design of Highways and Streets](#), 2018

\* The minimum value is based on the design speed; see Exhibits H.1, H.2, and H.3

- (3) Over the entire roadway width with an additional allowance for future resurfacing.
- (4) Grade may be up to 1% steeper for tangent length less than 500 ft.
- (5) For an AADT less than 2,000 vehicles/day, the grade may be up to 2% steeper for tangent length less than 500 ft.
- (6) Consider 12 ft. lanes for design speed  $\geq 55$  mph where substantial truck volumes are present or agricultural equipment frequently uses the road.
- (7) 9 ft. may be used for design speeds  $\leq 40$  mph with ADTs < 250 veh/day.
- (B) The surfaced shoulder cross slope should not be less than the cross slope of the adjacent lane.

<b>NEW AND RECONSTRUCTED RURAL STATE HIGHWAYS</b>		
<b>AASHTO CLASSIFICATION: RECREATIONAL ROADS</b>		
<b>STATE FUNCTIONAL CLASSIFICATION: MAJOR ARTERIAL – SCENIC RECREATION</b>		
<b>NATIONAL FUNCTIONAL CLASSIFICATION: COLLECTOR/LOCAL</b>		
	<b>ADT ≥ 400</b>	<b>ADT &lt; 400</b>
<b>Design Speed</b>	40 mph	30 mph
<b>Lane Width</b>	11 ft.	10 ft.
<b>Shoulder Width</b>	2 ft.	2 ft.
<b>Horizontal Alignment</b>		
<b>Superelevation</b>	$e_{max} = 6\%$	$e_{max} = 6\%$
<b>*Minimum Radius (Based on Max. Superelevation)</b>	485 ft. (paved roadway)	231 ft. (paved roadway)
<b>Vertical Alignment</b>		
<b>*Crest K Value</b>	44	19
<b>*Sag K Value</b>	64	37
<b>*Maximum Grade</b>	7% Level 9% Rolling	7% Level 10% Rolling
<b>*Stopping Sight Distance</b>	305 ft.	200 ft.
<b>Cross Slope</b>		
<b>Lane</b>	1.5% - 2% paved 2% - 6% aggregate (3% desirable)	1.5% - 2% paved 2% - 6% aggregate (3% desirable)
<b>Shoulder</b>	2% - 6% paved (B) 4% - 6% aggregate 6% - 8% turf	2% - 6% paved (B) 4% - 6% aggregate 6% - 8% turf
<b>Lateral Offset to Obstruction</b>	The shoulder width.	The shoulder width.
<b>Vertical Clearance (3)</b>	Structure: 14 ft. Sign trusses and pedestrian/bicycle overpass: Structure clearance + 1 ft.	Structure: 14 ft. Sign trusses and pedestrian/bicycle overpass: Structure clearance + 1 ft.
<b>Bridge Width</b>	Traveled way + 3 ft. on each side.	Traveled way + 2 ft. on each side.
<b>Structural Capacity</b>	HL93	HL93

For additional information, see [A Policy on Geometric Design of Highways and Streets, 2018](#)

\* The minimum value is based on the design speed; see Exhibits H.1, H.2, and H.3

(3) Over the entire roadway width with an additional allowance for future resurfacing.

(B) The surfaced shoulder cross slope should not be less than the cross slope of the adjacent lane.

<b>NEW AND RECONSTRUCTED MUNICIPAL STATE HIGHWAYS</b>	
<b>AASHTO CLASSIFICATION: INTERSTATE</b>	
<b>STATE FUNCTIONAL CLASSIFICATION: INTERSTATE</b>	
<b>NATIONAL FUNCTIONAL CLASSIFICATION: PRINCIPAL ARTERIAL – INTERSTATE</b>	
<b>Design Speed</b>	50 mph
<b>Lane Width</b>	12 ft.
<b>Shoulder Width</b>	Right = 10 ft. 4-Lane (2 lanes in each direction): Left = 4 ft. Truck Traffic > 250 DDHV: Right = 12 ft. should be considered ≥ 6-Lane (≥ 3 lanes in each direction): Left = 10 ft. Truck Traffic > 250 DDHV: Right & Left = 12 ft. should be considered (Note: All shoulder widths are paved).
<b>Horizontal Alignment</b>	
<b>Superelevation</b>	$e_{max} = 8\%$
<b>*Minimum Radius (Based on Maximum Superelevation)</b>	758 ft.
<b>Vertical Alignment</b>	
<b>*Crest K Value</b>	84
<b>*Sag K Value</b>	96
<b>*Maximum Grade</b>	4% Level 5% Rolling (Grades may be up to 1% steeper)
<b>*Stopping Sight Distance</b>	425 ft.
<b>Cross Slope</b>	
<b>Lane</b>	1.5% (A)
<b>Shoulder</b>	2% to 6% paved (B)
<b>Lateral Offset to Obstruction</b>	The nominal shoulder width.
<b>Vertical Clearance (1)</b>	Structure: 16 ft. for at least one route and 14 ft. for other routes. Sign trusses and pedestrian/bicycle overpass: Structure clearance + 1 ft.
<b>Bridge Width</b>	Full width of the approach roadway including paved shoulders. (D)
<b>Structural Capacity</b>	HL93

For additional information, see A Policy on Design Standards Interstate System, May 2016 and A Policy on Geometric Design of Highways and Streets, 2018

(1) Over the entire roadway width, including auxiliary lanes, shoulders, ramps, and collector-distributor roads.

\* The minimum value is based on the design speed; see Exhibits H.1, H.2, and H.3

(A) On roadways where there are more than two lanes inclined in the same direction, the cross slope may be increased by 0.5% to 1% for each additional lane, up to a maximum of 3%.

(B) The surfaced shoulder cross slope should not be less than the cross slope of the adjacent lane.

(D) Long bridges (longer than 200 ft.) may have a lesser width and should be analyzed individually. On long bridges a reduced shoulder width of 4 ft. may be used on both the left and right sides.



<b>NEW AND RECONSTRUCTED MUNICIPAL STATE HIGHWAYS</b>	
<b>AASHTO CLASSIFICATION: SUBURBAN FREEWAY</b>	
<b>STATE FUNCTIONAL CLASSIFICATION: EXPRESSWAY (ACCESS ONLY AT INTERCHANGES)</b>	
<b>NATIONAL FUNCTIONAL CLASSIFICATION: PRINCIPAL ARTERIAL – OTHER FREEWAYS AND EXPRESSWAYS</b>	
<b>Design Speed</b>	50 mph
<b>Lane Width</b>	12 ft.
<b>Shoulder Width</b>	Right = 10 ft. 4-Lane (2 lanes in each direction): Left = 4 ft. Truck Traffic > 250 DDHV: Right = 12 ft. should be considered ≥ 6-Lane (≥ 3 lanes in each direction): Left = 10 ft. Truck Traffic > 250 DDHV: Right & Left = 12 ft. should be considered (Note: All shoulder widths are paved).
<b>Horizontal Alignment</b>	
<b>Superelevation</b>	$e_{max} = 8\%$
<b>*Minimum Radius (Based on Maximum Superelevation)</b>	758 ft.
<b>Vertical Alignment</b>	
<b>*Crest K Value</b>	84
<b>*Sag K Value</b>	96
<b>*Maximum Grade</b>	4% Level 5% Rolling (Grades 1% steeper may be provided)
<b>*Stopping Sight Distance</b>	425 ft.
<b>Cross Slope</b>	
<b>Lane</b>	1.5% to 2% (A)
<b>Shoulder</b>	2% to 6% paved (C)
<b>Lateral Offset to Obstruction</b>	The nominal shoulder width.
<b>Vertical Clearance (2)</b>	Structure: 16 ft. for at least one route and 14 ft. for other routes. Sign trusses and pedestrian/bicycle overpass: Structure clearance + 1 ft.
<b>Bridge Width</b>	Full width of the approach roadway. (E)
<b>Structural Capacity</b>	HL93

For additional information, see [A Policy on Geometric Design of Highways and Streets](#), 2018

\* The minimum value is based on the design speed; see Exhibits H.1, H.2, and H.3

(2) Over the entire roadway width, including auxiliary lanes, shoulders, and collector-distributor roads.

(A) On roadways where there are more than two lanes inclined in the same direction, the cross slope may be increased by 0.5% to 1% for each additional lane, up to a maximum of 3%.

(C) The surfaced shoulder cross slope should not be less than the cross slope of the adjacent roadway lane and can be at least 1% greater.

(E) Bridges longer than 200 ft. may have a lesser width and should be analyzed individually.

<b>NEW AND RECONSTRUCTED MUNICIPAL STATE HIGHWAYS</b>	
<b>AASHTO CLASSIFICATION: URBAN FREEWAY</b>	
<b>STATE FUNCTIONAL CLASSIFICATION: EXPRESSWAY (ACCESS ONLY AT INTERCHANGES)</b>	
<b>NATIONAL FUNCTIONAL CLASSIFICATION: PRINCIPAL ARTERIAL – OTHER FREEWAYS AND EXPRESSWAYS</b>	
<b>Design Speed</b>	50 mph
<b>Lane Width</b>	12 ft.
<b>Shoulder Width</b>	Right = 10 ft. 4-Lane (2 lanes in each direction): Left = 4 ft. Truck Traffic > 250 DDHV: Right & Left = 12 ft. should be considered ≥ 6-Lane (≥ 3 lanes in each direction): Left = 10 ft. Truck Traffic > 250 DDHV: Right & Left = 12 ft. should be considered (Note: All shoulder widths are paved).
<b>Horizontal Alignment</b>	
<b>Superelevation</b>	$e_{max} = 8\%$
<b>*Minimum Radius (Based on Maximum Superelevation)</b>	758 ft.
<b>Vertical Alignment</b>	
<b>*Crest K Value</b>	84
<b>*Sag K Value</b>	96
<b>*Maximum Grade</b>	4% Level 5% Rolling (Grades 1% steeper may be provided)
<b>*Stopping Sight Distance</b>	425 ft.
<b>Cross Slope</b>	
<b>Lane</b>	1.5% to 2% (A)
<b>Shoulder</b>	2% to 6% paved (C)
<b>Lateral Offset to Obstruction</b>	The nominal shoulder width.
<b>Vertical Clearance (2)</b>	Structure: 16 ft. for at least one route and 14 ft. for other routes. Sign trusses and pedestrian/bicycle overpass: Structure clearance + 1 ft.
<b>Bridge Width</b>	Full width of the approach roadway. (D)
<b>Structural Capacity</b>	HL93

For additional information, see [A Policy on Geometric Design of Highways and Streets, 2018](#)

\* The minimum value is based on the design speed; see Exhibits H.1, H.2, and H.3

(2) Over the entire roadway width, including auxiliary lanes, shoulders, and collector-distributor roads.

(A) On roadways where there are more than two lanes inclined in the same direction, the cross slope may be increased by 0.5% to 1% for each additional lane, up to a maximum of 3%.

(C) The surfaced shoulder cross slope should not be less than the cross slope of the adjacent roadway lane and can be at least 1% greater.

(D) Bridges longer than 200 ft. may have a lesser width and should be analyzed individually.

NEW AND RECONSTRUCTED MUNICIPAL STATE HIGHWAYS	
<b>AASHTO CLASSIFICATION: URBAN CORE FREEWAY</b>	
<b>STATE FUNCTIONAL CLASSIFICATION: EXPRESSWAY (ACCESS ONLY AT INTERCHANGES)</b>	
<b>NATIONAL FUNCTIONAL CLASSIFICATION: PRINCIPAL ARTERIAL – OTHER FREEWAYS AND EXPRESSWAYS</b>	
<b>Design Speed</b>	50 mph
<b>Lane Width</b>	12 ft.
<b>Shoulder Width</b>	Right = 10 ft. 4-Lane (2 lanes in each direction): Left = 4 ft. Truck Traffic > 250 DDHV: Right & Left = 12 ft. should be considered ≥ 6-Lane (≥ 3 lanes in each direction): Left = 10 ft. Truck Traffic > 250 DDHV: Right & Left = 12 ft. should be considered (Note: All shoulder widths are paved).
<b>Horizontal Alignment</b>	
<b>Superelevation</b>	$e_{max} = 8\%$
<b>*Minimum Radius (Based on Maximum Superelevation)</b>	758 ft.
<b>Vertical Alignment</b>	
<b>*Crest K Value</b>	84
<b>*Sag K Value</b>	96
<b>*Maximum Grade</b>	4% Level 5% Rolling (Grades 1% steeper may be provided)
<b>*Stopping Sight Distance</b>	425 ft.
<b>Cross Slope</b>	
<b>Lane</b>	1.5% to 2% (A)
<b>Shoulder</b>	2% to 6% paved (C)
<b>Lateral Offset to Obstruction</b>	The nominal shoulder width.
<b>Vertical Clearance (2)</b>	Structure: 16 ft. for at least one route and 14 ft. for other routes. Sign trusses and pedestrian/bicycle overpass: Structure clearance + 1 ft.
<b>Bridge Width</b>	Full width of the approach roadway. (D)
<b>Structural Capacity</b>	HL93

For additional information, see [A Policy on Geometric Design of Highways and Streets, 2018](#)

\* The minimum value is based on the design speed; see Exhibits H.1, H.2, and H.3

(2) Over the entire roadway width, including auxiliary lanes, shoulders, and collector-distributor roads.

(A) On roadways where there are more than two lanes inclined in the same direction, the cross slope may be increased by 0.5% to 1% for each additional lane, up to a maximum of 3%.

(C) The surfaced shoulder cross slope should not be less than the cross slope of the adjacent roadway lane and can be at least 1% greater.

(D) Bridges longer than 200 ft. may have a lesser width and should be analyzed individually.

<b>NEW AND RECONSTRUCTED MUNICIPAL STATE HIGHWAYS</b>	
<b>AASHTO CLASSIFICATION: SUBURBAN ARTERIAL</b>	
<b>STATE FUNCTIONAL CLASSIFICATION: EXPRESSWAY</b>	
<b>NATIONAL FUNCTIONAL CLASSIFICATION: PRINCIPAL ARTERIAL – OTHER FREEWAYS AND EXPRESSWAYS</b>	
<b>Design Speed</b>	30 mph
<b>Lane Width</b>	11 ft.
<b>Shoulder Width</b>	Curbed: Not Applicable 8 ft. Right usable (paved is preferred, 4 ft. min. paved if used for bicycles) 4 ft. Left (paved) ≥ 6 Lane (≥ 3 lanes in each direction): Left = 8 ft.
<b>Horizontal Alignment</b>	
<b>Superelevation</b>	$e_{max} = 8\%$
<b>*Minimum Radius (Based on Maximum Superelevation)</b>	214 ft.
<b>Vertical Alignment</b>	
<b>*Crest K Value</b>	19
<b>*Sag K Value</b>	37
<b>*Maximum Grade (4)</b>	7% Level 9% Rolling
<b>*Stopping Sight Distance</b>	200 ft.
<b>Cross Slope</b>	
<b>Lane</b>	1.5% to 3% (A)
<b>Shoulder</b>	2% to 6% paved (B) 6% to 8% turf
<b>Lateral Offset to Obstruction</b>	Curbed: 1.5 ft. from face of the curb (3 ft. at intersections). Non-curbed: The greater of the shoulder width or 4 ft. from the edge of the travelled way.
<b>Vertical Clearance (3)</b>	Structure: 16 ft. (14 ft. may be retained if allowed by local statute). Sign trusses and pedestrian/bicycle overpass: Structure clearance + 1 ft.
<b>Bridge Width</b>	Curbed: The curb to curb width of the street, including sidewalks, bike paths and bike lanes. Non-curbed: The full width of the approach roadway including shoulders and pedestrian/bicycle facilities. Bridge L > 200 ft.: Shoulder width should be at least 4 ft.
<b>Structural Capacity</b>	HL93

For additional information, see [A Policy on Geometric Design of Highways and Streets](#), 2018

\* The minimum value is based on the design speed; see Exhibits H.1, H.2, and H.3

(3) Over the entire roadway width, including the usable width of shoulders.

(4) Grade may be up to 1% steeper for tangent lengths less than 500 ft.

(A) On roadways where there are more than two lanes inclined in the same direction, the cross slope may be increased by 0.5% to 1% for each additional lane, up to a maximum of 3%.

(B) The surfaced shoulder cross slope should not be less than the cross slope of the adjacent lane.

<b>NEW AND RECONSTRUCTED MUNICIPAL STATE HIGHWAYS</b>	
<b>AASHTO CLASSIFICATION: URBAN ARTERIAL</b>	
<b>STATE FUNCTIONAL CLASSIFICATION: EXPRESSWAY</b>	
<b>NATIONAL FUNCTIONAL CLASSIFICATION: PRINCIPAL ARTERIAL – OTHER FREEWAYS AND EXPRESSWAYS</b>	
<b>Design Speed</b>	25 mph
<b>Lane Width</b>	11 ft.
<b>Shoulder Width</b>	Curbed: Not Applicable 8 ft. Right usable (paved is preferred, 4 ft. min. paved if used for bicycles) 4 ft. Left (paved) ≥ 6 Lane (≥ 3 lanes in each direction): Left = 8 ft.
<b>Horizontal Alignment</b>	
<b>Superelevation</b>	$e_{max} = 8\%$
<b>*Minimum Radius (Based on Maximum Superelevation)</b>	134 ft.
<b>Vertical Alignment</b>	
<b>*Crest K Value</b>	12
<b>*Sag K Value</b>	26
<b>*Maximum Grade (4)</b>	7% Level 10% Rolling
<b>*Stopping Sight Distance</b>	155 ft.
<b>Cross Slope</b>	
<b>Lane</b>	1.5% to 3% (A)
<b>Shoulder</b>	2% to 6% paved (B) 6% to 8% turf
<b>Lateral Offset to Obstruction</b>	Curbed: 1.5 ft. from face of the curb (3 ft. at intersections). Non-curbed: The greater of the shoulder width or 4 ft. from the edge of the travelled way.
<b>Vertical Clearance (3)</b>	Structure: 16 ft. for one route & 14 ft. for other routes. Sign trusses and pedestrian/bicycle overpass: Structure clearance + 1 ft.
<b>Bridge Width</b>	Curbed: The curb to curb width of street, including sidewalks, bike paths and bike lanes. Non-curbed: The full width of the approach roadway including shoulders and pedestrian/bicycle facilities. Bridge L > 200 ft.: Shoulder width may be reduced to 4 ft.
<b>Structural Capacity</b>	HL93

For additional information, see [A Policy on Geometric Design of Highways and Streets, 2018](#)

\* The minimum value is based on the design speed; see Exhibits H.1, H.2, and H.3

- (3) Over the entire roadway width, including the usable width of shoulders.
- (4) Grade may be up to 1% steeper for tangent lengths less than 500 ft.
- (A) On roadways where there are more than two lanes inclined in the same direction, the cross slope may be increased by 0.5% to 1% for each additional lane, up to a maximum of 3%.
- (B) The surfaced shoulder cross slope should not be less than the cross slope of the adjacent lane.

<b>NEW AND RECONSTRUCTED MUNICIPAL STATE HIGHWAYS</b>	
<b>AASHTO CLASSIFICATION: URBAN CORE ARTERIAL STATE FUNCTIONAL CLASSIFICATION: EXPRESSWAY NATIONAL FUNCTIONAL CLASSIFICATION: PRINCIPAL ARTERIAL – OTHER FREEWAYS AND EXPRESSWAYS</b>	
<b>Design Speed</b>	30 mph
<b>Lane Width</b>	10 ft.
<b>Shoulder Width</b>	Curbed: Not Applicable 8 ft. Right usable (paved is preferred, 4 ft. min. paved if used for bicycles) 4 ft. Left (paved) ≥ 6 Lane (≥ 3 lanes in each direction): Left = 8 ft.
<b>Horizontal Alignment</b>	
<b>Superelevation</b>	$e_{max} = 8\%$
<b>*Minimum Radius (Based on Maximum Superelevation)</b>	214 ft.
<b>Vertical Alignment</b>	
<b>*Crest K Value</b>	19
<b>*Sag K Value</b>	37
<b>*Maximum Grade (4)</b>	7% Level 9% Rolling
<b>*Stopping Sight Distance</b>	200 ft.
<b>Cross Slope</b>	
<b>Lane</b>	1.5% to 3% (A)
<b>Shoulder</b>	2% to 6% paved (B) 6% to 8% turf
<b>Lateral Offset to Obstruction</b>	Curbed: 1.5 ft. from face of the curb (3 ft. at intersections). Non-curbed: The greater of the shoulder width or 4 ft. from the edge of the travelled way.
<b>Vertical Clearance (3)</b>	Structure: 16 ft. for one route & 14 ft. for other routes. Sign trusses and pedestrian/bicycle overpass: Structure clearance + 1 ft.
<b>Bridge Width</b>	Curbed: The curb to curb width of street, including sidewalks, bike paths and bike lanes. Non-curbed: The full width of the approach roadway including shoulders and pedestrian/bicycle facilities. Bridge L > 200 ft.: Shoulder width may be reduced to 4 ft.
<b>Structural Capacity</b>	HL93

For additional information, see [A Policy on Geometric Design of Highways and Streets](#), 2018

\* The minimum value is based on the design speed; see Exhibits H.1, H.2, and H.3

- (3) Over the entire roadway width, including the usable width of shoulders.
- (4) Grade may be up to 1% steeper for tangent lengths less than 500 ft.
- (A) On roadways where there are more than two lanes inclined in the same direction, the cross slope may be increased by 0.5% to 1% for each additional lane, up to a maximum of 3%.
- (B) The surfaced shoulder cross slope should not be less than the cross slope of the adjacent lane.

<b>NEW AND RECONSTRUCTED MUNICIPAL STATE HIGHWAYS</b>	
<b>AASHTO CLASSIFICATION: SUBURBAN ARTERIAL STATE FUNCTIONAL CLASSIFICATION: MAJOR ARTERIAL NATIONAL FUNCTIONAL CLASSIFICATION: ARTERIAL</b>	
<b>Design Speed</b>	30 mph
<b>Lane Width</b>	11 ft.
<b>Shoulder Width</b>	Curbed: Not Applicable ADT > 2,000 VPD: 8 ft. usable (paved is preferred) ADT 400 – 2,000 VPD: 6 ft. usable (paved is preferred) ADT < 400 VPD: 4 ft. usable (paved is preferred) (All shoulders - 4 ft. minimum should be paved if used for bicycles, a minimum of 2 ft. may be paved if low volumes and no bicycle use)
<b>Horizontal Alignment</b>	
<b>Superelevation</b>	$e_{max} = 8\%$
<b>*Minimum Radius (Based on Maximum Superelevation)</b>	214 ft.
<b>Vertical Alignment</b>	
<b>*Crest K Value</b>	19
<b>*Sag K Value</b>	37
<b>*Maximum Grade (4)</b>	7% Level 9% Rolling
<b>*Stopping Sight Distance</b>	200 ft.
<b>Cross Slope</b>	
<b>Lane</b>	1.5% to 3% (A)
<b>Shoulder</b>	2% to 6% paved (B) 6% to 8% turf
<b>Lateral Offset to Obstruction</b>	Curbed: 1.5 ft. from face of the curb (3 ft. at intersections). Non-curbed: The greater of the shoulder width or 4 ft. from the edge of the travelled way.
<b>Vertical Clearance (3)</b>	Structure: 16 ft. (14 ft. may be retained if allowed by local statute). Sign trusses and pedestrian/bicycle overpass: Structure clearance + 1 ft.
<b>Bridge Width</b>	Curbed: The curb to curb width of street, including sidewalks, bike paths and bike lanes. Non-curbed: The full width of the approach roadway including shoulders and pedestrian/bicycle facilities. Bridge L > 200 ft.: Shoulder width should be at least 4 ft.
<b>Structural Capacity</b>	HL93

For additional information, see [A Policy on Geometric Design of Highways and Streets](#), 2018

\* The minimum value is based on the design speed; see Exhibits H.1, H.2, and H.3

- (3) Over the entire roadway width, including the usable width of shoulders.
- (4) Grade may be up to 1% steeper for tangent lengths less than 500 ft.
- (A) On roadways where there are more than two lanes inclined in the same direction, the cross slope may be increased by 0.5% to 1% for each additional lane, up to a maximum of 3%.
- (B) The surfaced shoulder cross slope should not be less than the cross slope of the adjacent lane.

<b>NEW AND RECONSTRUCTED MUNICIPAL STATE HIGHWAYS</b>	
<b>AASHTO CLASSIFICATION: URBAN ARTERIAL</b>	
<b>STATE FUNCTIONAL CLASSIFICATION: MAJOR ARTERIAL</b>	
<b>NATIONAL FUNCTIONAL CLASSIFICATION: ARTERIAL</b>	
<b>Design Speed</b>	25 mph
<b>Lane Width</b>	11 ft.
<b>Shoulder Width</b>	Curbed: Not Applicable ADT > 2,000 VPD: 8 ft. usable (paved is preferred) ADT 400 – 2,000 VPD: 6 ft. usable (paved is preferred) ADT < 400 VPD: 4 ft. usable (paved is preferred) (All shoulders - 4 ft. minimum should be paved if used for bicycles, a minimum of 2 ft. may be paved if low volumes and no bicycle use)
<b>Horizontal Alignment</b>	
<b>Superelevation</b>	$e_{max} = 8\%$
<b>*Minimum Radius (Based on Maximum Superelevation)</b>	134 ft.
<b>Vertical Alignment</b>	
<b>*Crest K Value</b>	12
<b>*Sag K Value</b>	26
<b>*Maximum Grade (4)</b>	7% Level 10% Rolling
<b>*Stopping Sight Distance</b>	155 ft.
<b>Cross Slope</b>	
<b>Lane</b>	1.5% to 3% (A)
<b>Shoulder</b>	2% to 6% paved (B) 6% to 8% turf
<b>Lateral Offset to Obstruction</b>	Curbed: 1.5 ft. from face of the curb (3 ft. at intersections). Non-curbed: The greater of the shoulder width or 4 ft. from the edge of the travelled way.
<b>Vertical Clearance (3)</b>	Structure: 16 ft. for one route & 14 ft. for other routes. Sign trusses and pedestrian/bicycle overpass: Structure clearance + 1 ft.
<b>Bridge Width</b>	Curbed: The curb to curb width of street, including sidewalks, bike paths and bike lanes. Non-curbed: The full width of the approach roadway including shoulders and pedestrian/bicycle facilities. Bridge L > 200 ft.: Shoulder width may be reduced to 4 ft.
<b>Structural Capacity</b>	HL93

For additional information, see [A Policy on Geometric Design of Highways and Streets](#), 2018

\* The minimum value is based on the design speed; see Exhibits H.1, H.2, and H.3

- (3) Over the entire roadway width, including the usable width of shoulders.
- (4) Grade may be up to 1% steeper for tangent lengths less than 500 ft.
- (A) On roadways where there are more than two lanes inclined in the same direction, the cross slope may be increased by 0.5% to 1% for each additional lane, up to a maximum of 3%.
- (B) The surfaced shoulder cross slope should not be less than the cross slope of the adjacent lane.



<b>NEW AND RECONSTRUCTED MUNICIPAL STATE HIGHWAYS</b>	
<b>AASHTO CLASSIFICATION: URBAN CORE ARTERIAL STATE FUNCTIONAL CLASSIFICATION: MAJOR ARTERIAL NATIONAL FUNCTIONAL CLASSIFICATION: ARTERIAL</b>	
<b>Design Speed</b>	30 mph
<b>Lane Width</b>	10 ft.
<b>Shoulder Width</b>	Curbed: Not Applicable ADT > 2,000 VPD: 8 ft. usable (paved is preferred) ADT 400 – 2,000 VPD: 6 ft. usable (paved is preferred) ADT < 400 VPD: 4 ft. usable (paved is preferred) (All shoulders - 4 ft. minimum should be paved if used for bicycles, a minimum of 2 ft. may be paved if low volumes and no bicycle use)
<b>Horizontal Alignment</b>	
<b>Superelevation</b>	$e_{max} = 8\%$
<b>*Minimum Radius (Based on Maximum Superelevation)</b>	214 ft.
<b>Vertical Alignment</b>	
<b>*Crest K Value</b>	19
<b>*Sag K Value</b>	37
<b>*Maximum Grade (4)</b>	7% Level 9% Rolling
<b>*Stopping Sight Distance</b>	200 ft.
<b>Cross Slope</b>	
<b>Lane</b>	1.5% to 3% (A)
<b>Shoulder</b>	2% to 6% paved (B) 6% to 8% turf
<b>Lateral Offset to Obstruction</b>	Curbed: 1.5 ft. from face of the curb (3 ft. at intersections). Non-curbed: The greater of the shoulder width or 4 ft. from the edge of the travelled way.
<b>Vertical Clearance (3)</b>	Structure: 16 ft. for one route & 14 ft. for other routes. Sign trusses and pedestrian/bicycle overpass: Structure clearance + 1 ft.
<b>Bridge Width</b>	Curbed: The curb to curb width of street, including sidewalks, bike paths and bike lanes. Non-curbed: The full width of the approach roadway including shoulders and pedestrian/bicycle facilities. Bridge L > 200 ft.: Shoulder width may be reduced to 4 ft.
<b>Structural Capacity</b>	HL93

For additional information, see [A Policy on Geometric Design of Highways and Streets](#), 2018

\* The minimum value is based on the design speed; see Exhibits H.1, H.2, and H.3

- (3) Over the entire roadway width, including the usable width of shoulders.
- (4) Grade may be up to 1% steeper for tangent lengths less than 500 ft.
- (A) On roadways where there are more than two lanes inclined in the same direction, the cross slope may be increased by 0.5% to 1% for each additional lane, up to a maximum of 3%.
- (B) The surfaced shoulder cross slope should not be less than the cross slope of the adjacent lane.

<b>NEW AND RECONSTRUCTED MUNICIPAL STATE HIGHWAYS</b>	
<b>AASHTO CLASSIFICATION: SUBURBAN COLLECTOR STATE FUNCTIONAL CLASSIFICATION: MAJOR ARTERIAL NATIONAL FUNCTIONAL CLASSIFICATION: COLLECTOR</b>	
<b>Design Speed</b>	35 mph
<b>Lane Width</b>	10 ft.
<b>Shoulder Width</b>	Curbed: Not Applicable ADT > 2,000 VPD: 6 ft. ADT 400 – 2,000 VPD: 4 ft. ADT < 400 VPD: 2 ft.
<b>Horizontal Alignment</b>	
<b>Superelevation</b>	$e_{max} = 8\%$
<b>*Minimum Radius (Based on Maximum Superelevation)</b>	314 ft.
<b>Vertical Alignment</b>	
<b>*Crest K Value</b>	29
<b>*Sag K Value</b>	49
<b>*Maximum Grade (5)</b>	7% Level 9% Rolling
<b>*Stopping Sight Distance</b>	250 ft.
<b>Cross Slope</b>	
<b>Lane</b>	1.5% to 3% (A)
<b>Shoulder</b>	2% to 6% paved (B) 6% to 8% turf
<b>Lateral Offset to Obstruction</b>	Curbed: 1.5 ft. from face of the curb (3 ft. at intersections). Non-curbed: The greater of the shoulder width or 4 ft. from the edge of the travelled way.
<b>Vertical Clearance (3)</b>	Structure: 14 ft. Sign trusses and pedestrian/bicycle overpass: Structure clearance + 1 ft.
<b>Bridge Width</b>	Curbed: The curb to curb width of the approach roadway. Non-curbed: The full width of the approach roadway, sidewalks on the approaches should be extended across the structure.
<b>Structural Capacity</b>	HL93

For additional information, see [A Policy on Geometric Design of Highways and Streets](#), 2018

\* The minimum value is based on the design speed; see Exhibits H.1, H.2, and H.3

- (3) Over the entire roadway width with additional allowance for resurfacing.
- (5) For an AADT less than 2,000 vehicles/day, the grade may be up to 2% steeper for tangent length less than 500 ft.
- (A) On roadways where there are more than two lanes inclined in the same direction, the cross slope may be increased by 0.5% to 1% for each additional lane, up to a maximum of 3%.
- (B) The surfaced shoulder cross slope should not be less than the cross slope of the adjacent lane.

<b>NEW AND RECONSTRUCTED MUNICIPAL STATE HIGHWAYS</b>	
<b>AASHTO CLASSIFICATION: URBAN COLLECTOR</b>	
<b>STATE FUNCTIONAL CLASSIFICATION: MAJOR ARTERIAL</b>	
<b>NATIONAL FUNCTIONAL CLASSIFICATION: COLLECTOR</b>	
<b>Design Speed</b>	30 mph
<b>Lane Width</b>	10 ft.
<b>Shoulder Width</b>	Curbed: Not Applicable ADT > 2,000 VPD: 6 ft. ADT 400 – 2,000 VPD: 4 ft. ADT < 400 VPD: 2 ft.
<b>Horizontal Alignment</b>	
<b>Superelevation</b>	$e_{max} = 6\%$
<b>*Minimum Radius (Based on Maximum Superelevation)</b>	231 ft.
<b>Vertical Alignment</b>	
<b>*Crest K Value</b>	19
<b>*Sag K Value</b>	37
<b>*Maximum Grade (4)</b>	9% Level 11% Rolling
<b>*Stopping Sight Distance</b>	200 ft.
<b>Cross Slope</b>	
<b>Lane</b>	1.5% to 3% (A)
<b>Shoulder</b>	2% to 6% paved (B) 6% to 8% turf
<b>Lateral Offset to Obstruction</b>	Curbed: 1.5 ft. from face of the curb (3 ft. at intersections). Non-curbed: The greater of the shoulder width or 4 ft. from the edge of the travelled way.
<b>Vertical Clearance (3)</b>	Structure: 14 ft. Sign trusses and pedestrian/bicycle overpass: Structure clearance + 1 ft.
<b>Bridge Width</b>	Curbed: The curb to curb width of the approach roadway. Non-curbed: The full width of the approach roadway, sidewalks on the approaches should be extended across the structure.
<b>Structural Capacity</b>	HL93

For additional information, see [A Policy on Geometric Design of Highways and Streets](#), 2018

\* The minimum value is based on the design speed; see Exhibits H.1, H.2, and H.3

- (3) Over the entire roadway width with additional allowance for resurfacing.
- (4) Grade may be up to 1% steeper for tangent lengths less than 500 ft.
- (A) On roadways where there are more than two lanes inclined in the same direction, the cross slope may be increased by 0.5% to 1% for each additional lane, up to a maximum of 3%.
- (B) The surfaced shoulder cross slope should not be less than the cross slope of the adjacent lane.

<b>NEW AND RECONSTRUCTED MUNICIPAL STATE HIGHWAYS</b>	
<b>AASHTO CLASSIFICATION: URBAN CORE COLLECTOR</b>	
<b>STATE FUNCTIONAL CLASSIFICATION: MAJOR ARTERIAL</b>	
<b>NATIONAL FUNCTIONAL CLASSIFICATION: COLLECTOR</b>	
<b>Design Speed</b>	25 mph
<b>Lane Width</b>	10 ft.
<b>Shoulder Width</b>	Curbed: Not Applicable ADT > 2,000 VPD: 6 ft. ADT 400 – 2,000 VPD: 4 ft. ADT < 400 VPD: 2 ft.
<b>Horizontal Alignment</b>	
<b>Superelevation</b>	$e_{max} = 6\%$
<b>*Minimum Radius (Based on Maximum Superelevation)</b>	144 ft.
<b>Vertical Alignment</b>	
<b>*Crest K Value</b>	12
<b>*Sag K Value</b>	26
<b>*Maximum Grade (4)</b>	9% Level 12% Rolling
<b>*Stopping Sight Distance</b>	155 ft.
<b>Cross Slope</b>	
<b>Lane</b>	1.5% to 3% (A)
<b>Shoulder</b>	2% to 6% paved (B) 6% to 8% turf
<b>Lateral Offset to Obstruction</b>	Curbed: 1.5 ft. from face of the curb (3 ft. at intersections). Non-curbed: The greater of the shoulder width or 4 ft. from the edge of the travelled way.
<b>Vertical Clearance (3)</b>	Structure: 14 ft. Sign trusses and pedestrian/bicycle overpass: Structure clearance + 1 ft.
<b>Bridge Width</b>	Curbed: The curb to curb width of the approach roadway. Non-curbed: The full width of the approach roadway, sidewalks on the approaches should be extended across the structure.
<b>Structural Capacity</b>	HL93

For additional information, see [A Policy on Geometric Design of Highways and Streets](#), 2018

\* The minimum value is based on the design speed; see Exhibits H.1, H.2, and H.3

- (3) Over the entire roadway width with additional allowance for resurfacing.
- (4) Grade may be up to 1% steeper for tangent lengths less than 500 ft.
- (A) On roadways where there are more than two lanes inclined in the same direction, the cross slope may be increased by 0.5% to 1% for each additional lane, up to a maximum of 3%.
- (B) The surfaced shoulder cross slope should not be less than the cross slope of the adjacent lane.

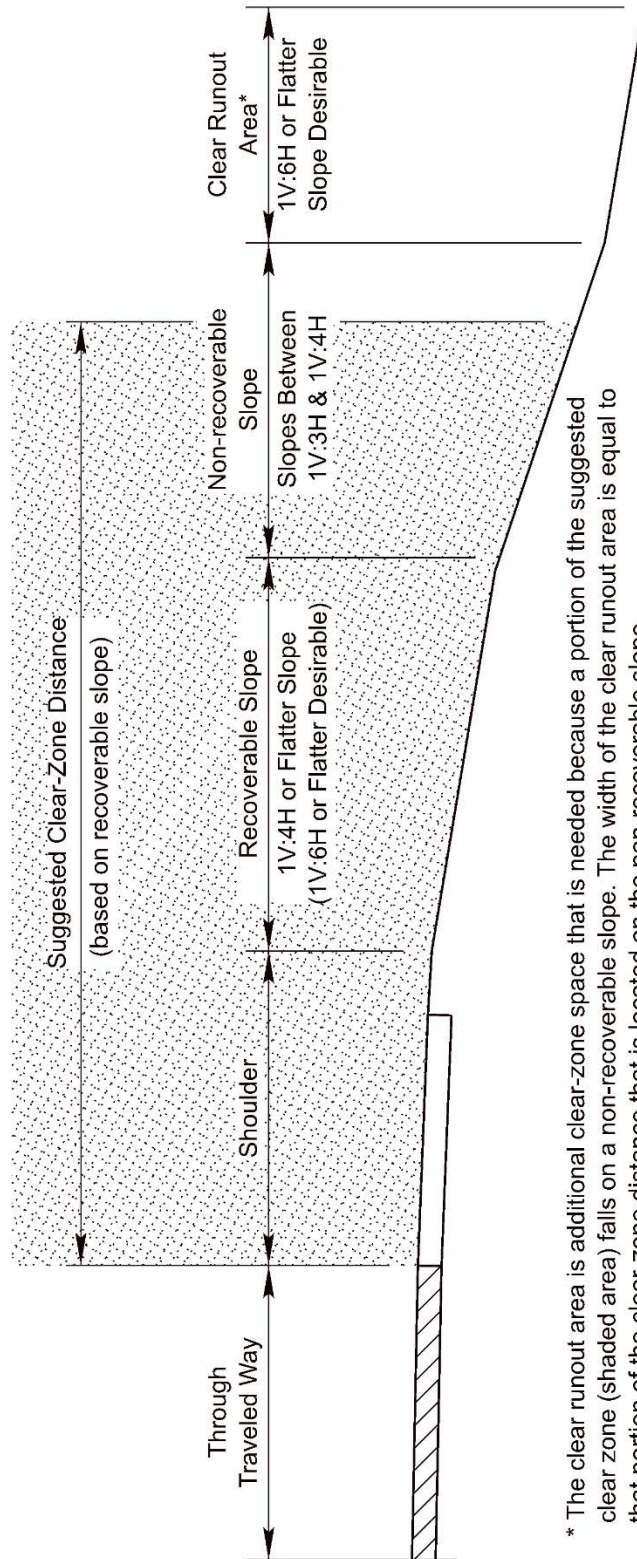
Design Speed (mph)	Design ADT	Foreslopes			Backslopes		
		1V:6H or flatter	1V:5H to 1V:4H	1V:3H	1V:3H	1V:5H to 1V:4H	1V:6H or flatter
≤ 40	UNDER 750 <sup>C</sup>	7 – 10	7 – 10	B	7 – 10	7 – 10	7 – 10
	750 – 1500	10 – 12	12 – 14	B	12 – 14	12 – 14	12 – 14
	1500 – 6000	12 – 14	14 – 16	B	14 – 16	14 – 16	14 – 16
	OVER 6000	14 – 16	16 – 18	B	16 – 18	16 – 18	16 – 18
45 – 50	UNDER 750 <sup>C</sup>	10 – 12	12 – 14	B	8 – 10	8 – 10	10 – 12
	750 – 1500	14 – 16	16 – 20	B	10 – 12	12 – 14	14 – 16
	1500 – 6000	16 – 18	20 – 26	B	12 – 14	14 – 16	16 – 18
	OVER 6000	20 – 22	24 – 28	B	14 – 16	18 – 20	20 – 22
55	UNDER 750 <sup>C</sup>	12 – 14	14 – 18	B	8 – 10	10 – 12	10 – 12
	750 – 1500	16 – 18	20 – 24	B	10 – 12	14 – 16	16 – 18
	1500 – 6000	20 – 22	24 – 30	B	14 – 16	16 – 18	20 – 22
	OVER 6000	22 – 24	26 – 32 <sup>A</sup>	B	16 – 18	20 – 22	22 – 24
60	UNDER 750 <sup>C</sup>	16 – 18	20 – 24	B	10 – 12	12 – 14	14 – 16
	750 – 1500	20 – 24	26 – 32 <sup>A</sup>	B	12 – 14	16 – 18	20 – 22
	1500 – 6000	26 – 30	32 – 40 <sup>A</sup>	B	14 – 18	18 – 22	24 – 26
	OVER 6000	30 – 32 <sup>A</sup>	36 – 44 <sup>A</sup>	B	20 – 22	24 – 26	26 – 28
65 – 70 <sup>D</sup>	UNDER 750 <sup>C</sup>	18 – 20	20 – 26	B	10 – 12	14 – 16	14 – 16
	750 – 1500	24 – 26	28 – 36 <sup>A</sup>	B	12 – 16	18 – 20	20 – 22
	1500 – 6000	28 – 32 <sup>A</sup>	34 – 42 <sup>A</sup>	B	16 – 20	22 – 24	26 – 28
	OVER 6000	30 – 34 <sup>A</sup>	38 – 46 <sup>A</sup>	B	22 – 24	26 – 30	28 – 30

**Notes:**

- A) When a site – specific investigation indicates a high probability of continuing crashes or when such occurrences are indicated by crash history, the designer may provide clear-zone distances greater than the clear zone shown in Table 3-1. Clear zones may be limited to 30 ft. for practicality and to provide a consistent roadway template if previous experience with similar projects or designs indicates satisfactory performance.
- B) Because recovery is less likely on the unshielded, traversable 1V:3H fill slopes, fixed objects should not be present in the vicinity of the toe of these slopes. Recovery of high-speed vehicles that encroach beyond the edge of the shoulder may be expected to occur beyond the toe of slope. Determination of the width of the recovery area at the toe of slope should consider right-of-way availability, environmental concerns, economic factors, safety needs, and crash histories. Also, the distance between the edge of the through traveled lane and the beginning of the 1V:3H slope should influence the recovery area provided at the toe of slope. While the application may be limited by several factors, the foreslope parameters that may enter into determining a maximum desirable recovery area are illustrated in Figure 3-2. A 10-ft. recovery area at the toe of slope should be provided for all traversable, non-recoverable fill slopes.
- C) For roadways with low volumes it may not be practical to apply even the minimum values found in Table 3-1. Refer to Chapter 12 for additional considerations for low-volume roadways and Chapter 10 for additional guidance for urban applications.
- D) When design speeds are greater than the values provided, the designer may provide clear-zone distances greater than those shown in Table 3-1.

**Table 3-1. Suggested Clear-Zone Distances in Feet from Edge of Through Traveled Lane**

Source: American Association of State Highway and Transportation Officials: Roadside Design Guide (2011)



\* The clear runout area is additional clear-zone space that is needed because a portion of the suggested clear zone (shaded area) falls on a non-recoverable slope. The width of the clear runout area is equal to that portion of the clear-zone distance that is located on the non-recoverable slope.

Figure 3-2. Clear Zone for Non-Recoverable Parallel Foreslope

Source: Adapted from American Association of State Highway and Transportation Officials: Roadside Design Guide (2011)

Figure 3-2. Clear Zone for Non-Recoverable Parallel Slope

DESIGN CRITERIA DEPENDENT ON SPEED – NEW AND RECONSTRUCTED PROJECTS														
CRITERIA	DESIGN SPEED (mph)													
	15	20	25	30	35	40	45	50	55	60	65	70	75	80
Minimum Radius														
Max. Super. 8%	38 ft.	76 ft.	134 ft.	214 ft.	314 ft.	444 ft.	587 ft.	758 ft.	960 ft.	1200 ft.	1480 ft.	1810 ft.	2210 ft.	2670 ft.
Max. Super. 6%	39 ft.	81 ft.	144 ft.	231 ft.	340 ft.	485 ft.	643 ft.	833 ft.	1060 ft.	1330 ft.	1660 ft.	2040 ft.	2500 ft.	3050 ft.
Max. Super. 4%	42 ft.	86 ft.	154 ft.	250 ft.	371 ft.	533 ft.	711 ft.	926 ft.	1190 ft.	1500 ft.	---	---	---	---
* Crest K Value	3	7	12	19	29	44	61	84	114	151	193	247	312	384
* Sag K Value	10	17	26	37	49	64	79	96	115	136	157	181	206	231
* Stopping Sight Distance	80 ft.	115 ft.	155 ft.	200 ft.	250 ft.	305 ft.	360 ft.	425 ft.	495 ft.	570 ft.	645 ft.	730 ft.	820 ft.	910 ft.

Source: American Association of State and Highway Transportation Officials, A Policy on Geometric Design of Highways and Streets (2018) Tables 3-7, 3-35, and 3-37.

\* For NDOT desirable values see the Roadway Design Manual, Chapter Three: Roadway Alignment, EXHIBITS 3.9 AND 3.14. The use of less than the desirable value, down to and including the values given in this table, require Roadway Design Unit Head approval. The use of values less than those given in this table will require a Relaxation of the Nebraska Minimum Standards and, if required, a Design Exception from the FHWA (see Section 2, "Departure from Standards" of this document).

AASHTO CLASSIFICATION/ STATE FUNCTIONAL CLASSIFICATION		MAXIMUM ALLOWABLE GRADES – NEW & RECONSTRUCTED RURAL PROJECTS													
		DESIGN SPEED (mph)													
TERRAIN		15	20	25	30	35	40	45	50	55	60	65	70	75	80
INTERSTATE/ INTERSTATE	Level	---	---	---	---	---	---	---	4%	4%	3%	3%	3%	3%	3%
	Rolling	---	---	---	---	---	---	---	5%	5%	4%	4%	4%	4%	4%
FREEWAY/ EXPRESSWAY (ACCESS ONLY AT INTERCHANGES)	Level	---	---	---	---	---	---	---	4%	4%	3%	3%	3%	3%	3%
	Rolling	---	---	---	---	---	---	---	5%	5%	4%	4%	4%	4%	4%
RURAL DIVIDED ARTERIAL/ EXPRESSWAY (A)	Level	---	5%	5%	5%	5%	5%	5%	4%	4%	3%	3%	3%	3%	3%
	Rolling	---	8%	8%	7%	7%	6%	6%	5%	5%	4%	4%	4%	4%	4%
RURAL TOWN DIVIDED ARTERIAL/ EXPRESSWAY (A)	Level	---	5%	5%	5%	5%	5%	5%	4%	4%	3%	3%	3%	3%	3%
	Rolling	---	8%	8%	7%	7%	6%	6%	5%	5%	4%	4%	4%	4%	4%
RURAL ARTERIAL/ MAJOR ARTERIAL (A)	Level	---	5%	5%	5%	5%	5%	5%	4%	4%	3%	3%	3%	3%	3%
	Rolling	---	8%	8%	7%	7%	6%	6%	5%	5%	4%	4%	4%	4%	4%
RURAL TOWN ARTERIAL/ MAJOR ARTERIAL (A)	Level	---	8%	8%	7%	7%	6%	6%	5%	5%	4%	4%	4%	4%	4%
	Rolling	---	7%	7%	7%	7%	7%	7%	6%	6%	5%	5%	5%	5%	5%
RURAL COLLECTOR/ MAJOR ARTERIAL - COLLECTOR (B)	Level	---	7%	7%	7%	7%	7%	7%	6%	6%	5%	5%	5%	5%	5%
	Rolling	---	10%	10%	9%	9%	8%	8%	7%	7%	6%	6%	6%	6%	6%
RURAL TOWN COLLECTOR/ MAJOR ARTERIAL - COLLECTOR (B)	Level	---	7%	7%	7%	7%	7%	7%	6%	6%	5%	5%	5%	5%	5%
	Rolling	---	10%	10%	9%	9%	8%	8%	7%	7%	6%	6%	6%	6%	6%
RECREATIONAL ROADS/ MAJOR ARTERIAL - SCENIC RECREATION	Level	8%	8%	7%	7%	7%	7%	7%	7%	7%	6%	6%	6%	6%	6%
	Rolling	12%	11%	10%	10%	9%	9%	9%	9%	9%	8%	8%	8%	8%	8%

Sources: American Association of State and Highway Transportation Officials publications, A Policy on Geometric Design of Highways and Streets (2018) Tables 5-7, 6-2, 7-2, and 8-1 and A Policy on Design Standards Interstate System (May 2016) Table 2

- (A) Grades may be up to 1% steeper for tangent lengths less than 500 feet.
- (B) Grades may be up to 2% steeper for tangent lengths less than 500 feet.

Exhibit H.2 Maximum Allowable Grades – New and Reconstructed Rural Projects



MAXIMUM ALLOWABLE GRADES – NEW & RECONSTRUCTED MUNICIPAL PROJECTS																	
ASHTO CLASSIFICATION/ STATE FUNCTIONAL CLASSIFICATION	TERRAIN	DESIGN SPEED (mph)															
		20	25	30	35	40	45	50	55	60	65	70	75	80			
INTERSTATE/ INTERSTATE (D)	Level	---	---	---	---	---	---	---	---	---	---	4%	4%	3%	3%	3%	3%
	Rolling	---	---	---	---	---	---	---	---	---	---	5%	5%	4%	4%	4%	4%
SUBURBAN FREEWAY/ EXPRESSWAY (ACCESS ONLY AT INTERCHANGES) (D)	Level	---	---	---	---	---	---	---	---	---	---	4%	4%	3%	3%	3%	3%
	Rolling	---	---	---	---	---	---	---	---	---	---	5%	5%	4%	4%	4%	4%
URBAN FREEWAY/ EXPRESSWAY (ACCESS ONLY AT INTERCHANGES) (D)	Level	---	---	---	---	---	---	---	---	---	---	4%	4%	3%	3%	3%	3%
	Rolling	---	---	---	---	---	---	---	---	---	---	5%	5%	4%	4%	4%	4%
URBAN CORE FREEWAY/ EXPRESSWAY (ACCESS ONLY AT INTERCHANGES) (D)	Level	---	---	---	---	---	---	---	---	---	---	4%	4%	3%	3%	3%	3%
	Rolling	---	---	---	---	---	---	---	---	---	---	5%	5%	4%	4%	4%	4%
SUBURBAN ARTERIAL/ EXPRESSWAY (A)	Level	8%	7%	7%	7%	7%	7%	7%	7%	7%	7%	6%	6%	5%	5%	5%	5%
	Rolling	10%	10%	9%	8%	8%	8%	8%	8%	8%	8%	7%	7%	6%	6%	6%	6%
URBAN ARTERIAL/ EXPRESSWAY (A)	Level	10%	10%	9%	8%	8%	8%	8%	8%	8%	8%	7%	7%	6%	6%	6%	6%
	Rolling	10%	10%	9%	8%	8%	8%	8%	8%	8%	8%	7%	7%	6%	6%	6%	6%
URBAN CORE ARTERIAL/ EXPRESSWAY (A)	Level	10%	10%	9%	8%	8%	8%	8%	8%	8%	8%	7%	7%	6%	6%	6%	6%
	Rolling	10%	10%	9%	8%	8%	8%	8%	8%	8%	8%	7%	7%	6%	6%	6%	6%
SUBURBAN ARTERIAL/ MAJOR ARTERIAL (A)	Level	8%	7%	7%	7%	7%	7%	7%	7%	7%	7%	6%	6%	5%	5%	5%	5%
	Rolling	10%	10%	9%	8%	8%	8%	8%	8%	8%	8%	7%	7%	6%	6%	6%	6%
URBAN ARTERIAL/ MAJOR ARTERIAL (A)	Level	8%	7%	7%	7%	7%	7%	7%	7%	7%	7%	6%	6%	5%	5%	5%	5%
	Rolling	10%	10%	9%	8%	8%	8%	8%	8%	8%	8%	7%	7%	6%	6%	6%	6%
URBAN CORE ARTERIAL/ MAJOR ARTERIAL (A)	Level	8%	7%	7%	7%	7%	7%	7%	7%	7%	7%	6%	6%	5%	5%	5%	5%
	Rolling	10%	10%	9%	8%	8%	8%	8%	8%	8%	8%	7%	7%	6%	6%	6%	6%
SUBURBAN COLLECTOR/ MAJOR ARTERIAL (B)	Level	7%	7%	7%	7%	7%	7%	7%	7%	7%	7%	6%	6%	5%	5%	5%	5%
	Rolling	10%	10%	9%	8%	8%	8%	8%	8%	8%	8%	7%	7%	6%	6%	6%	6%
URBAN COLLECTOR/ MAJOR ARTERIAL (A)	Level	9%	9%	9%	9%	9%	9%	9%	9%	9%	9%	8%	8%	7%	7%	7%	7%
	Rolling	12%	12%	11%	10%	10%	10%	10%	10%	10%	10%	9%	8%	8%	7%	7%	7%
URBAN CORE COLLECTOR/ MAJOR ARTERIAL (A)	Level	9%	9%	9%	9%	9%	9%	9%	9%	9%	9%	8%	8%	7%	7%	7%	7%
	Rolling	12%	12%	11%	10%	10%	10%	10%	10%	10%	10%	9%	8%	8%	7%	7%	7%

Sources: American Association of State and Highway Transportation Officials publications, A Policy on Geometric Design of Highways and Streets (2018) Tables 6-2, 6-7, 7-4a, and 8-1 and A Policy on Design Standards Interstate System (May 2016) Table 2

- (A) Grades may be up to 1% steeper for tangent lengths less than 500 feet.
- (B) Grades may be up to 2% steeper for tangent lengths less than 500 feet.
- (D) Grades 1% steeper than the value shown may be used in urban areas.

Exhibit H.3 Maximum Allowable Grades – New and Reconstructed Municipal Projects



## Installation of the Beveled Edge

The beveled edge is a mitigation measure for roadway departure crashes, intended to allow a smoother recovery to the roadway for an errant vehicle that has departed the roadway hard surfacing. The beveled edge, a sloping finish to the edge of pavement, is an effective measure, recommended by the **Federal Highway Administration (FHWA)**, to reduce the frequency and severity of run-off-the-road crashes by reducing tire scrubbing and allowing for a smooth re-entry of errant vehicles to the travelled way.

This treatment of the pavement edge is a recognized and recommended crash mitigation measure by **FHWA**; therefore, if the average roadway departure crash rate for rural two-lane roads shows the addition of a beveled edge to be safety beneficial, Federal-aid Highway Safety Improvement Program (HSIP) funds may be used for that purpose. This may be done on individual projects or on a system-wide basis. Additionally, per 23 CFR 924.5(c), "Other Federal-aid funds are eligible to support and leverage the safety program. Improvements to safety features that are routinely provided as part of a broader Federal-aid project should be funded from the same source as the broader project." A project specific benefit-cost calculation will not be required. The beveled edge will be installed on projects or segments of projects where the following conditions are met:

1. Rural, high speed (posted speed  $\geq$  50 mph) segments of the State Highway System.
2. Asphalt concrete and Portland Cement Concrete pavements.
3. 3R, reconstruction, and new projects with at least two inches of surfacing placement (the beveled edge will not be used on resurfacing projects where less than two inches of surfacing is placed).
4. Surfaced shoulders less than six feet in width, not including segments of erosion control curbed shoulders.
5. Non-curbed roadways.
6. Other projects in locations identified by the **Traffic Engineering Division** as a mitigation measure for a crash history.

The beveled edge may be used in conjunction with rumble stripes (8 inches strip embedded in the pavement marking).



**NEBRASKA DEPARTMENT OF TRANSPORTATION**

**GUIDELINES FOR ADDRESSING WORK  
ZONE MOBILITY AND SAFETY**

**JOHN CRAIG, DIRECTOR**

**MONTY FREDRICKSON, DEPUTY DIRECTOR – ENGINEERING**  
**JOHN JACOBSEN, DEPUTY DIRECTOR – OPERATIONS**

**Nebraska Department of Transportation Mission Statement**

**"We provide and maintain, in cooperation with public and private organizations, a safe, reliable, affordable, environmentally compatible, and coordinated statewide transportation system for the movement of people and goods."**

**In keeping with this mission statement, the Nebraska Department of Transportation is committed to developing, implementing, and improving these guidelines as a means to provide an adequate level of service and work zone safety for motorists and highway workers alike.**

## SECTION 1 - PURPOSE (23 C.F.R §630.1002)

In keeping with the mission of the Department of Transportation, these guidelines for addressing work zone mobility and safety have been adopted so that reasonable effort is made from inception of the project to construction and final acceptance to accommodate the safety and mobility of all workers and travelers in our work zones for which the Department is responsible, including federal and local projects.

This guide was developed by a multi-disciplinary team including representatives of the Nebraska Department of Transportation and the Federal Highway Administration. This document is a guide and is intended for use as a resource document.

## SECTION 2 - DEFINITIONS AND TERMS (23 C.F.R § 630.1004)

**Design Process Outline (DPO)** --- A summary of major activities (tasks or work categories) to be completed during the course of a project's design.

**Highway Workers** --- Include, but are not limited to, personnel of the contractor, subcontractor, NDOT, local agencies, utilities, and law enforcement, performing work within the right-of-way of a work zone.

**Mobility** --- The ability to move from place to place and is significantly dependent on the availability of transportation facilities and on system operating conditions. With specific reference to work zones, mobility pertains to moving road users efficiently through or around a work zone area with a minimum delay compared to baseline travel when no work zone is present, while not compromising the safety of highway workers or road users. The commonly used performance measures for the assessment of mobility include delay, speed, travel time and queue lengths.

**Safety** --- A representation of the level of exposure to potential hazards for users of transportation facilities and highway workers. With specific reference to work zones, safety refers to minimizing potential hazards to road users in the vicinity of a work zone and highway workers at the work zone interface with traffic.

**Significant Project** --- Generally, a project, whether alone or in combination with other projects nearby, that may cause sustained work zone impacts on such things as capacity, delay times, levels of service, congestion, etc. that are greater than what is considered tolerable or desirable based on policy and/or engineering judgment.

**Surveillance of Temporary Traffic Control Devices** --- A contractor-managed pay item utilized to compensate the contractor for the continuous (24/7) monitoring and maintenance activities required in association with the work zone traffic control on the projects. Contractor employees assigned to these tasks require training and certification by the Contractor.

**Traffic Control Plan (TCP)** --- A plan used for facilitating road users through a work zone or an incident area.

**Traffic Control Management (TCM)** --- A contractor-managed pay item which normally requires three daily inspections of the work zone, monitoring of corrective action required, and documentation of the inspections made and corrective action taken. Contractor employees assigned to these tasks require training and certification by the Contractor.

**Transportation Management Plan (TMP)** --- An organized strategy to manage the work zone impacts of a project. Its scope, content, and degree of detail will vary depending on project requirements, these guidelines, and the anticipated impacts of the project on the traveling public.

**Transportation Operations Component (TO)** --- That component of a Transportation Management Plan (TMP) that identifies strategies that may be used to mitigate impacts of the work zone on the operation and management of the transportation system within the work zone impact area.

**Work Zone** --- An area within the right of way of a highway with construction, maintenance, or utility work activities. A work zone is typically marked by signs, channelizing devices, barriers, pavement markings, and/or work vehicles. It extends from the first warning sign to the END ROAD WORK sign. In the case of mobile operation, it extends from the first warning sign or identifiable warning light to the last temporary control device.

**Work Zone Crash** --- A traffic crash in which the first harmful event occurs within the boundaries of a work zone or on an approach to or exit from a work zone, resulting from an activity, behavior, or control related to the movement of the traffic units through the work zone. This includes crashes occurring on approach to, exiting from or adjacent to work zones that are related to the work zone.

**Work Zone Impacts** --- Work zone-induced deviations from the normal range of transportation system safety and mobility. The extent of the work zone impacts may vary based on factors such as, road classification, area type (urban, suburban, and rural), traffic and travel characteristics, type of work being performed, time of day/night, and complexity of the project. These impacts may extend beyond the physical location of the work zone itself and may occur on the roadway on which the work is being performed, as well as other highway corridors, other modes of transportation, and/or the regional transportation network.

Additionally, the Department includes the following acronyms in these guidelines:

- **AASHTO** --- American Association of State Highway and Transportation Officials

**ATSSA** --- American Traffic Safety Services Association

**CBD** --- Central Business District

**CFR** --- Code of Federal Regulations

**CMS** --- Changeable Message Signs

**DPO** --- Design Process Outline

**FHWA** --- Federal Highway Administration

**ER** - Federal Register

**ITS** --- Intelligent Transportation System

**MAPA** --- Metropolitan Area Planning Agency

**MUTCD** --- Manual on Uniform Traffic Control Devices

**PI** --- Public Information

**PS & E** --- Plans, Specifications, and Estimates

**TCM** --- Traffic Control Management

**TCP** --- Traffic Control Plan (same as TTC --- Temporary Traffic Control)

**TMA** --- Transportation Management Area

**TMP** --- Transportation Management Plan

**TO** --- Transportation Operations

### **SECTION 3 - STATE-LEVEL PROCESSES AND PROCEDURES (23 C.F.R § 630.1008)**

#### (a.) Section Description

This section addresses the Department's state-level processes and procedures for work zone assessment, work zone data, training, and periodic evaluations (process reviews).

#### (b.) Work Zone Assessment and Management

The Construction Division's Final Plans Section reviews all plans for constructability, establishes time allowances, and estimates the signing quantities for each project. These tasks should be accomplished with consideration given to the standard or special traffic control plans developed by Traffic Engineering Division and any phasing plans developed by the Roadway Design Division. The Final Plans Section, in consultation with the Traffic Engineering Division, may make additions or deletions to the various plans when appropriate and necessary.

The Final Plans Section writes "Special Prosecution and Progress" specifications, when needed, which relate to traffic control. These special provisions address incentives/disincentives, internal District liquidated damages, peak hours, lane closures, and phasing required for the construction of the project where applicable.

This work is accomplished in collaboration with the District involved, the Roadway Design Division, and the Construction Division, by considering such factors as traffic volumes, anticipated delays, detour routes, the need to maintain two lanes of traffic on multilane facilities, and impacts to communities, schools, and emergency services.

Throughout the design process of a project, the Final Plans Section is available for project review to determine preliminary time allowances, assess constructability issues, and discuss phasing and traffic control. This preliminary review process is part of the Design Process Outline (DPO).

For projects that do not go through the Roadway Design Division (such as pavement rehabilitation projects generated in the Materials & Research Division), the Traffic Engineering Division determines the applicable standard or special traffic control plans. The Final Plans Section, in cooperation with the District and Traffic Engineering Division, determines the signing quantities, phasing, peak hours, or special prosecution/progress specifications that may be required.



The Department may utilize "Traffic Control Management" or "Surveillance of Temporary Traffic Control Devices" in addition to the standard and/or special traffic control plans. Each District, in cooperation with the Construction Division, determines whether to use "Traffic Control Management", "Surveillance", or just the normal traffic control methods provided by the Plans and Specifications. This determination is done just prior to the Final Plans Section review.

(c.) Work Zone Data

The Accident Records Section of the Traffic Engineering Division collects work zone crash data.

The Traffic Engineering Division summarizes the information received and processed by the Highway Safety Section and then prepares and distributes a Work Zone Accident Report Summary to the Districts on a monthly basis. The District project managers and other District staff are then expected to address any work zone mobility and safety issues by reacting to the Work Zone Accident Report Summary and making field observations of travel speed, delays, and other factors which might affect travel through the work zone.

Whenever the District's review and analysis of the work zone and Work Zone Accident Report Summary identifies opportunities for improvement or results in positive changes to work zone safety and mobility, the nature of the findings or improvements are communicated to the Traffic Engineering and/or Construction Divisions, or others as appropriate.

Additionally, the Department utilizes work zone crash data as one of its own performance measures. The work zone crash data shall be available for use during work zone process reviews and used as a tool to improve traffic control plans and guidelines.

(d.) Training

The Department currently generates the forms used to report crash data and provides to law enforcement some limited training on the proper and consistent collection of work zone crash data. The Department monitors the crash data being collected and pursues additional training for law enforcement if it is deemed necessary by the Department.

The Department provides appropriate training for employees involved in the development, design, implementation, management, and inspection of work zone-related transportation management and traffic control. The Department to the extent practical maintains a record of required training provided and provides appropriate training updates when necessary. Additionally, the Department will provide other training when necessary by the Department or the Federal Highway Administration (FHWA).

The Department selects training which is compatible with the needs involved and the class and position of employees to be trained. The Department avails itself of on-the-job training by peers and supervisors, electronic media presentations, and large and small group presentations, or at informal safety meetings.

Department personnel actively involved in the workzone (project managers, key inspectors, etc.) are encouraged to complete flagger and Assistant Traffic Control Manager certification training.

District personnel involved in the review and analysis of the monthly Work Zone Accident Report Summaries and District personnel responsible for implementing and monitoring the Traffic Management Plan on a significant project will, when available, attend American Traffic Safety Services Association (ATSSA) training for Traffic Control Technicians or Traffic Control Supervisors. Certification from ATSSA is not required.

Additionally, for positions or circumstances requiring more formal training, the Department will either provide appropriate in-house training or arrange for training which may be available from the Federal Highway Administration, (including National Highway Institute), ATSSA, or other outside training sources as needed.

When appropriate, the Department will make its training available to contractors.

By specification, the Department requires training and certification of contractor employees utilized as flaggers. The Department enforces the specification and provides training and certification materials as appropriate.

When provided in the Proposal, the Department requires that the contractor assign an individual as a Traffic Control Manager. Assistant Traffic Control Managers may be assigned and utilized by the contractor to perform required tasks on the project. The Department establishes training and certification requirements for Traffic Control Managers and Assistant Traffic Control Managers, enforces the specifications and provides training and certification materials as appropriate.

The Department utilizes Traffic Control Management or a similar level of traffic monitoring on significant projects. In so doing, the contractor's designated Traffic Control Manager will have received training in the implementation and monitoring of the Traffic Management Plan.

The Construction Division maintains (for the period of their respective certifications) a database of individuals (non-NDOT employees) who have been trained, certified, and reported as having completed the training and certification requirements for Flaggers and Assistant Traffic Control Managers. The Human Resources Division maintains a database of Department employees who have received flagger training.

#### (e.) Process Reviews

The Traffic Engineering Division, in partnership with the FHWA, conducts an annual statewide work zone inspection and process review. Construction and appropriate District personnel may be included in the reviews.

Observations made during the inspection and process review are summarized and analyzed by the Traffic Engineering Division and then shared with the Districts involved. The information is used to evaluate current work zone procedures and make recommendations for improvements.

Additional process reviews may be conducted in concert with the FHWA when deemed necessary.

## SECTION 4-SIGNIFICANT PROJECTS (23 C.F.R § 630.1010)

### (a) Acknowledgement of Significant Projects

The Department acknowledges that some projects, whether alone or in combination with other concurrent projects nearby, may cause sustained work zone impacts that are greater than what is considered tolerable or desirable based on policy and/or engineering judgment. These projects shall be identified as "significant projects".

### (b.) Identification of Significant Projects

A project is considered a "Significant Project" when it will impede traffic by closing lanes for several days or restricting width to the point that it slows traffic enough to cause delays and as described below.

Based on their experience and considering the criteria identified in 630.1010 (c.) below, each District Engineer identifies on the DR Form 73, Highway Improvement Programming Request, their recommendation as to whether a programmed project should be significant.

The Project Scheduling & Program Management Section, in consultation with the District Engineer and other Divisions and by evaluating one or more of the criteria referenced in 630.1010 (c), shall make the initial determination of whether a project is to be identified as a "significant project" as it relates to Subpart J of 23 CFR Part 630.

A final determination of significance shall be made during the Plan-in-Hand inspection.

### (c.) Criteria for Identification of Significant Projects

In addition to other projects that may qualify, the Department shall identify all projects on the Interstate System that are located within the boundaries of the Transportation Management Areas (TMA) of Omaha and Lincoln as "significant projects" if they are expected to occupy a location for more than three (3) days with either intermittent or continuous lane closures.

The TMA limits for Omaha include all of 1-680, all of 1-480, and that portion of 1-80 between Highway N-50 and the Missouri River. The TMA limits for Lincoln include all of 1-180 and that portion of 1-80 from 1 mile west of the NW 48th Street Interchange to 98th Street (1 mile west of the Waverly interchange). These limits are current as of 2007 but are subject to periodic review. The Metropolitan Area Planning Agency (MAPA) or the Lincoln/Lancaster County MPO should be consulted to verify the current TMA limits for Omaha and Lincoln.

Additionally, using the following criteria, the Department, including the District Engineer's initial assessment, will review other non-Interstate projects on the freeway or expressway system, projects located in a central business district or a major metropolitan area, and any other major projects to see if their work zone impacts are expected to be greater than what is considered tolerable. These projects may also be identified and treated as "significant projects".

Potential Criteria for Assessing the "Significance" of a Project:

1. Project Characteristics --- to include but not be limited to project type, type of work zone (full closure, lane reductions, cross-overs, night work, etc.), project schedule, area type (urban, suburban, rural).
2. Travel and Traffic Characteristics --- to include but not be limited to traffic volumes, seasonal and temporal variations, vehicle mix, type of travel (commuter, tourist, freight), public and private access, special events, impacts of weather.
3. Work Zone Characteristics --- to include but not be limited to impacts on local and regional transportation networks, capacity issues, level of public interest, number of travelers impacted, expected safety impacts, expected delays, impacts on nearby commercial, public, and private facilities and properties.

(d.) Exceptions

When the Department's analysis of a project on the Interstate System indicates that the work will not cause sustained work zone impacts, though otherwise meeting the criteria identified in 4c., the Department may request from the FHWA an exception to the applicability of 5b.2 and 5b.3 by showing that the project does not, in fact, cause sustained work zone impacts.

## **SECTION 5 - PROJECT LEVEL PROCEDURES (23 C.F.R § 630.1012)**

(a.) Section Description

This section provides guidance and establishes procedures to manage the work zone impacts of individual projects.

The Department addresses the traffic concerns on the Plan-In-Hand. While some Interstate projects can maintain two lanes of traffic, the majority of projects maintain one lane of traffic. Some projects use detours or phasing to maintain traffic at acceptable levels.

(b.) Transportation Management Plans-Mandate for Significant Projects

For projects determined to be significant, the Department will develop a Transportation Management Plan (TMP) which consists of a Traffic Control Plan (TCP), a component to address Transportation Operations (TO), and a component to address the dissemination of Public Information (PI). In general, the construction project manager is designated as being responsible for monitoring the TMP.

For individual projects or classes of projects determined not to be significant, only a TCP is required. However, TO and PI components may be considered and utilized on any project.

(b.1.) Traffic Control Plans

The Department prepares a TCP for every project where traffic is affected. TCP's are consistent with the applicable provisions of the MUTCD, and the AASHTO Roadside Design Guide.

The selection of standard TCP's and any special plans are made by the Traffic Engineering Division and submitted to the PS&E Section for inclusion in the project plans. Standard and special plans included in the contract documents may be modified or supplemented by other site-specific plans prepared by the District Highway Project Manager (or a designee).

The project TCP, as described above, addresses phasing when appropriate and is updated and modified when circumstances dictate. On relatively simple and uncomplicated projects, the project manager may find it sufficient to utilize only the standard and special plans (if any) provided in the contract documents.

In the case of existing obstacles adjacent to the traveled way which may be encountered or affected during construction, the obstacles will be reviewed in regard to the posted speed, traffic volumes, and the length of time the obstacle may present a hazard in accordance with the Roadside Design Guide and a cost/benefit analysis. Based on the review, obstacles will then either be left in place, delineated or shielded as appropriate for the project.

(b.2.) Transportation Operations (TO) Component Transportation Operations

On projects that have been determined to be significant, Transportation Operations (TO) strategies will be considered throughout the design process. The TO component of the TMP will include strategies that will be used to mitigate the impacts of the work zone on the operation and management of the highway system within the work zone impact area.

Transportation Operation strategies may include, but are not limited to:

1. Demand management,
2. Corridor/network management,
3. Work zone safety management, and
4. Traffic/Incident Management and Enforcement

The scope of the TO component will be determined by the project characteristics and the transportation operation and safety strategies identified by the Department.

1. Demand Management Strategies

Demand management strategies include techniques intended to reduce the volume of traffic traveling through the work zone by such methods as diverting travelers to alternate modes of transportation, shifting trips to off-peak hours, or shifting vehicles to alternate routes. When determining strategies to be used, the following may be considered:

- Transit Services - improvements, incentives, shuttles, residential/carpool, park and ride
- Ramp Metering, ramp closures
- Variable work hours; telecommuting

## 2. Corridor/Network Management Strategies

Corridor/network management strategies include strategies to optimize traffic flow through the work zone and adjacent roadways. The following traffic operations techniques and technologies may be considered:

- Maintaining existing number of through lanes
- Designing crossovers/shooflies for posted or 85th percentile speed
- Utilizing off-peak work hours
- Utilizing temporary traffic signals; monitoring signal timing/coordination
- Utilizing roadway/intersection improvements; turn lanes, bus turn outs
- Implementing traffic restrictions; turns, parking, trucks
- Implementing lane restrictions; trucks, reversible lanes
- Monitoring railroad crossing controls
- Coordinating with adjacent construction sites
- Utilizing automated work zones; detection systems, changeable message signs, highway advisory radio, web page, 511
- Various computer computations analyses (such as traffic modeling, Quickzone, etc.)

## 3. Work Zone Safety Management Strategies

Work zone safety management strategies include devices, features, and management procedures used to address traffic safety issues in the work zone. Work zone safety management strategies include:

- Reasonable speed limits through work area
- Temporary traffic signals
- Temporary traffic barriers - concrete protection barriers
- Impact attenuators/crash-cushions
- Intrusion alarms - warning lights
- Project task force/committee
- Work zone traffic control supervisors/inspectors
- Project partnering - weekly meetings
- Peer-to-peer work zone reviews
- Windshield surveys, night-time reviews

## 4. Traffic/Incident Management and Enforcement Strategies

Traffic/incident management and enforcement includes various strategies to manage work zone traffic operations. Work zone traffic management strategies involve monitoring traffic conditions and making adjustments to traffic operations based on changing conditions. Strategies in this area include:

- Automated work zones, traffic monitoring
- Transportation management centers, District Operations Centers
- Detecting and monitoring traffic for speed, volume, and density
- Traffic screens, glare screens
- Enhanced Reference Post markers
- Quick removal policies, push bumpers, hi-tech accident documentation
- Coordination with media
- Local detour routes

- Contract support for incident management
- Incident/emergency management coordination and response planning
- Utilizing automated work zones; detection systems, changeable message signs, highway advisory radio, web page, 511
- Law enforcement- cooperative, dedicated, or overtime
- Double fines for speeding

The strategies identified above are not all inclusive. Other strategies may be used.

While the Department is committed to implementing the appropriate strategies listed above on all projects determined to be "significant", many of these strategies may be implemented on other projects having a "less significant" impact on work zone safety and mobility.

### (b.3) Public Information (PI) Component

The Department makes a conscious effort to gather and share information regarding current and future projects with the public.

For projects identified as being "significant", the individual Districts take the lead in advising the Communication Division that the project is likely to be significant and that some special efforts may be needed to enhance the distribution of public information. The Districts provide as much lead time as possible.

The Department, through collaboration with other agencies, considers one or more of the following strategies when establishing a public information plan for an individual project. Each project is considered on its own merits in evaluating the types of strategies utilized and the extent to which resources are expended on them.

- Participation in National Work Zone Awareness Week activities.
- Maintenance of the Department of Transportation website. (The website is available to disseminate information both prior to and after the letting of a project.)
- Publication and distribution of various printed materials (flyers, doorhangers, newsletters, special mailings, etc.)
- Issuance of news releases to the media
- Placing project information on the "511" system.
- Conducting public information meetings at scheduled times throughout the life of a project.
- Deploying and employing various ITS options (e.g. Dynamic Message Signs).
- Utilizing paid advertising in the media, when justified and appropriate (this would include both print and electronic media).
- Utilizing free media advertising when available.
- Establishing a project-specific "hot line" when appropriate.
- Participate in public outreach whenever possible and appropriate (appearances at organizational meetings, public gatherings, etc.)
- Develop project-specific art work and graphics to identify special projects.

The individual Districts responsible for the projects involved, along with the Communication Division, monitors the results of the public information effort by surveying Department personnel and affected local agencies and individuals. Public information strategies may be modified as necessary.

(b.4.) Implementation of TMP with Stakeholders

The Department seeks the input of and keeps all affected agencies and individuals aware of the key details in the TMP and also encourages their continued involvement in the process.

It is understood that the actual list of stakeholders identified for any project will be unique, and it is not possible to outline the make-up of the list until the project is developing. However, the Department maintains a role in the functioning of the transportation management teams in the Omaha and Lincoln areas providing an ongoing involvement in the development of TMPs affecting most significant projects.

Current Inter-Agency Transportation Management Teams:

1. The Omaha "Transportation Systems Management" (TSM) Committee is represented by engineers and managers from the Nebraska Department of Transportation District and Central headquarters; Nebraska State Patrol; the City of Omaha Public Works Department, Police, Fire, and Transit Divisions; Douglas County and Sarpy County; Omaha Public Power District (OPPD), FHWA and the Metropolitan Area Planning Agency (MAPA). This group meets quarterly to discuss, coordinate, and mitigate the impact of road construction projects scheduled by the various jurisdictions. The TSM committee is led by the District 2 Office of the Nebraska Department of Transportation.
2. The Lincoln "Transportation Liaison Committee" (TLC) is represented by engineers and managers from multiple agencies in the Lincoln area. Included in this committee are representatives from the Nebraska Department of Transportation, District and Central Headquarters, FHWA, the City of Lincoln Public Works, Lancaster County and the Lincoln Electric System (LES). This committee meets bi-annually to discuss, coordinate, and mitigate the impact of road construction projects scheduled by the various jurisdictions. The Lincoln TLC is led by the City of Lincoln.

(c.) PS&E Requirements for TMP

The Department is responsible for the TMP. Contractors shall not be responsible for its development.

The Department identifies in the contract Proposal that the project is significant, and or identifies specific components of the TMP that are required for the project. Special provisions, special plans, and references to other pertinent documents are considered part of the TMP even if not separately identified and labeled as such. Items in the TMP that are the Department's sole responsibility are not included in the Proposal.

(d.) Method of Payment

In general, the Department utilizes method-based specifications for traffic control items. The Department's Standard Specifications do contain some isolated guidance that could be construed as "performance-based" (e.g., a pilot car is expected to make a round trip through a construction zone in 15 minutes). However, the Department utilizes individual pay items in the contract to pay for traffic control operations and devices. In some instances, payment for certain devices may be made subsidiary to others. For example, payment for the standard set of warning signs required for a flagging operation is subsidiary to the pay item, "Flagging".

Unless some project-specific special circumstances dictate, no specific items will be established to pay for implementation of the TMP. It is the Department's practice that payment for individual traffic control devices and for items such as "Traffic Control Management" provides the necessary compensation.



(e.) Designation of Responsible Persons

Unless special circumstances dictate, the NDOT Project Manager assigned to the construction of a project has the primary responsibility for implementing and monitoring the TMP. The Contractor shall identify, prior to construction, to the Department's Project Manager the individual(s) responsible for guaranteeing that the contractor's responsibilities under the TMP are properly and promptly carried out.

**SECTION 6 - IMPLEMENTATION**  
**(23 C.F.R § 630.1014)**

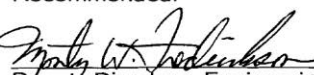
The Department acknowledges that its implementation of these guidelines is subject to review and reassessment annually. The Department is working in partnership with the FHWA Division office to implement its policies and procedures to improve work zone safety and mobility.


A copy of this document, or revised and amended copies thereof, shall be addressed in stewardship agreements with the FHWA.

**SECTION 7 - COMPLIANCE DATE**  
**(23 C.F.R § 630.1016)**

As of October 12, 2007, these guidelines shall be applied to all projects.

For projects that are in the final stages of development on or about October 12, 2007, and for which it can be demonstrated that complete compliance with these guidelines would create a significant negative impact upon their delivery, the Department agrees to request a variance, on a project-by-project basis, from the FHWA.

Recommended:  
  
Deputy Director – Engineering      10/15/07      Date

Recommended:  
  
Deputy Director – Operations      10-15-07      Date

Approved:  
  
NDOR – Director      02/17/2012      Date

Approved:  
  
FHWA Division Administrator      10/15/07      Date



# **PROJECT COORDINATION MEETINGS**

## **Establish Needed Inputs, Meeting Protocol, and Documentation Guidance**



## **ACRONYMS, ABBREVIATIONS AND SYMBOLS:**

CE	Categorical Exclusion
CE 1	Categorical Exclusion Level 1
CE 2	Categorical Exclusion Level 2
CE 3	Categorical Exclusion Level 3
CM	Coordination Meeting
DPO	Design Process Outline
EA	Environmental Assessment
EDU	Environmental Documents Unit
EDUM	Environmental Documents Unit Manager
EIS	Environmental Impact Statement
EPM	Environmental Project Manager
ER	Environmental Report
M&R	Materials & Research Division
NEPA	National Environmental Policy Act
PA	Programmatic Agreement
PCM	Project Coordination Meeting
PIH	Plan-In-Hand
PIP	Public Involvement Plan
PS&E	Plans, Specifications and Estimates
PSPM	Project Scheduling and Program Management
PSS	Project Scheduling System
RD	Roadway Design
ROW	Right-of-Way
RDCU	Roadside Development and Compliance Unit
SDLSS	Scoping Documents and Location Studies Supervisor
T&E	Threatened and Endangered
TRU	Technical Resources Unit

## **DEFINITIONS:**

NEPA Document – The NEPA document is the Environmental Document. To avoid confusion within this document, the environmental document will be referred to as the NEPA document, whether an EIS,CE (Level 1, 2 or 3),or an EA.

Environmental Documentation – Supporting environmental documentation including, but not limited to, agency correspondence, wetland permits, floodplain certifications and permits, Section 4(f) documents (park and recreational land, wildlife and waterfowl refuges, and historical sites), Section 106, threatened and endangered species documentation, and hazardous material documentation.



**PROJECT COORDINATION MEETING 20**  
**END OF PHASE 2 DURING THE PLANNING PHASE:**

**WHEN MEETING OCCURS:**

- After Phase 1 Program Phase
- At the end of Phase 2 Planning Phase
- After ground survey has been completed

**INFORMATION NEEDED AND HAS BEEN COMPLETED/COLLECTED:**

- Crash Data (Traffic)
- Planning Level Assessment of whether ROW acquisition may be required (RD/ROW)
- Planning Level Assessment of whether Permanent/Temporary Easements may be required (RD/ROW)
- Planning Level Assessment of whether driveways or County Roads be realigned (RD)
- Pavement Determination (M&R)
- Bridge Determination (Bridge)
- Presence Determination of EJ/LEP Population (HR)
- Ground Survey completed (Roadway Design)
- Possible Impacts determined (Roadway/Environmental)
- Planning Environmental Review (Environmental)
- Preliminary Bridge TS&L to Roadway Design (Bridge)
- Preliminary NEPA Level Determination (Environmental)
- Preliminary Public Involvement Plan (Communication)
- DR-73 Planning Document (Program Management)
  - Floodplain Present
  - Floodway Present
  - Curb and Flume Construction – sufficient shoulder width to construct
  - Culverts Replacement, Removal, Construction, Extensions (Y or N?)
  - Grading Beyond the shoulder hinge point likely?
  - ROW Needed
- MS4 Form A (RDC)
- T&E Checklist (RD)

**PURPOSE OF MEETING:**

- Review the DR-73 Planning Document to determine if any changes are needed.
- Review Project Length via Google Earth
- Identify Environmentally Sensitive Areas. Review environmental resources and determine if additional field surveys are required.
- Answer questions needed to update the Planning Environmental Review.
- Discuss design and environmental requirements that could impact the NEPA document and/or environmental documentation, project scope, project schedule, and project design.
- Confirm preliminary environmental class/level (CE – Level 1, 2, or 3/EA/EIS).
- Confirm project is assignable to NDOT under 326 MOU
- PSPM Coordinator will determine if the schedule needs to be adjusted based on impacts.

- Estimate and determine if wetland mitigation will be necessary. If so, will it be mitigated at a bank or mitigated on site. If on-site mitigation is required, then site selection and design would need to be completed.
- Review the Public Information Plan

**WHAT TO PROVIDE AT MEETING:**

- Planning Document and Discussion of Project Scope (OnBase – PD)
- Google Earth .kmz file – RD
- Environmental Resources (Google Earth .kmz file - EDU)

**ATTENDEES:**

- Bridge Management Engineer
- Bridge Hydraulics Engineer
- District Representative
- Environmental Documents Unit Coordinator
- Environmental Documents Unit Manager
- Environmental Permits Unit Coordinator
- Environmental Permits Unit Manager
- Environmental Section Manager (Optional)
- Hazmat, Air & Noise Coordinator
- Project Scheduling Program Management Coordinator
- Public Involvement Coordinator
- Roadway Design Engineer Unit Head
- Roadway Design Engineer/Designer
- Roadway Design Environmental Liaison Engineer
- Roadway Design Hydraulics Engineer
- Roadway Design Utilities Unit Head
- Roadway Design Utilities Coordinator
- Roadway Design Section Head (Optional)
- Roadside Stabilization Unit Erosion Control Designer
- Section 106/Historic Coordinator
- Technical Documents Unit Manager
- Threatened & Endangered Species Biologist



**Project Coordination Meeting 20** (Clarity Task 5290)  
(Conduct at the End of Phase 2, Planning Phase)

Proj No.:	Proj Name:			Control No.:	Date:
Designer: <input type="checkbox"/>	EPU Biologist: <input type="checkbox"/>	EDU Analyst: <input type="checkbox"/>	Next Meeting:		
T&E Biologist: <input type="checkbox"/>	Section 106 Coordinator <input type="checkbox"/>	Hazmat, Air & Noise Coordinator <input type="checkbox"/>	District Representative: <input type="checkbox"/>		
Design Unit Head: <input type="checkbox"/>	Bridge: <input type="checkbox"/>	Bridge Hydraulics: <input type="checkbox"/>	PSPM: <input type="checkbox"/>		
PS&E:	Project Scoping: <input type="checkbox"/>	Environmental Project Manager: <input type="checkbox"/>	RDC: <input type="checkbox"/>		
Letting:	Public Involvement: <input type="checkbox"/>	Utilities Unit Head: <input type="checkbox"/>	Utilities Coordinator: <input type="checkbox"/>		

**Other Attendees:**

**Information Provided:**

- Planning Document (OnBase and Summary Provided by RDHEL)
- Project kmz, covering Project Length (Google Earth .kmz file – RD)
- Environmental Resources (Google Earth .kmz file – EDU)
- NDOT-53 Approved

**Meeting Agenda:**

- Project Scoping to start review of project-unless Traffic or ITS Project
- Project Designer to provide additional project review-Review Project Length via Google Earth KMZ
- Identify environmentally sensitive areas. Review environmental resources and determine if additional field surveys are required.
- Review the NDOT-73 Planning Report
  - PSPM Coordinator will identify critical path, risks and concerns
  - Determine if Mitigation Bank is available if needed for project
  - Identify if an early site visit will be used instead of a PIH visit
  - Identify red flags, e.g. MS4, no wetland banks, levees, etc.
  - Action Items may include Super Team discussion thresholds and change control forms
- Review the decisions made in the Probable Class of Action (NDOT-53), and if project is assignable to NDOT
- Identify if the project is located in whole or in part within the boundaries of a tribal land
- Review the Public Information Plan

NEPA/NDOT-53:

**Identify Potential Resource Impacts:**

- Right-of-Way Required:
  - National Wild and Scenic River or National Recreational River:
  - Floodplain / Floodway:
  - Section 404 Wetland / Stream Impacts:
  - Section 408 Levees, reservoirs, civil works projects Present:
  - Section 9 – Coast Guard Permit:
  - Threatened & Endangered Species:
  - Section 106 (Historic):
  - Hazmat, Noise & Air:
  - Section 4f (Park, recreational lands, wildlife, waterfowl refuges, historic sites):
  - Traffic Disruptions (Temporary Road, Detour or Ramp Closure):
  - Property Access Restrictions:
  - Environmental Justice – Minority / Low Income Populations:
  - Public Involvement:
- 

**Summary of Project Description:**

**Notes:**

**Action Items:**

**PROJECT COORDINATION MEETING 30**  
**PHASE 3 PRIOR TO PLAN-IN-HAND VISIT:**

**WHEN MEETING OCCURS:**

- After Phase 2 Planning Phase
- Before completing the PIH visit.

**INFORMATION NEEDED AND HAS BEEN COMPLETED/COLLECTED:**

- Bridge Borings (M&R)
  - Preliminary Geo-Tech Finding (Driven Pile vs Drilled Shaft)
- Pavement Determination Review (M&R)
- Bridge Determination Review (Bridge)
- Environmental Surveys (T&E, Section 106, Hazmat)
- Wetland delineation (EPU)
- Preliminary Waterway Permit Data Sheet DR290 (RD)
- Design Environmental Review (EDU)

**PURPOSE OF MEETING:**

- Provide information necessary to begin environmental/NEPA process
- Discuss Project Scope and any updates since PCM 20
- Discuss bridge scope and construction methods
- Discuss detours and/or phasing needed for the project
- Discuss traffic impacts
- Discuss construction schedule and constructability topics
- Discuss right-of-way impacts
- Discuss utility impacts
- Discuss railroad coordination
- Discuss lighting
- Discuss local impacts
- Discuss environmental impacts

**WHAT TO PROVIDE AT MEETING:**

- Pre-PIH Design covering project length (Google Earth .kmz file – RD)
- Preliminary T&E Checklist (OnBase – RD)
- Project Schedule Update (PIH, PS&E turn-in, Letting)

**ATTENDEES:**

See Project Coordination Meeting 30 Template for meeting invitees and attendees, as needed.



Template: PCM 30 (rev 11-05-2020)

**Project Coordination Meeting 30** (Clarity Task 5315)

CN. \_\_\_\_\_, Project No. \_\_\_\_\_

Project Name \_\_\_\_\_

Date: \_\_\_\_\_

*(Preliminary Plans/quantities should be submitted to attendees at least one week prior to this meeting.)*

**Welcome - Purpose of Meeting & Introductions**

This meeting is to provide answers about the project that are necessary to begin the environmental/NEPA process.

**Attendees (Use Checkbox to Document Attendance)**

<input type="checkbox"/>		Bridge Hydraulics
<input type="checkbox"/>		Bridge Section Head
<input type="checkbox"/>		Communications and Public Policy
		Communications and Public Policy
		Communications and Public Policy
<input type="checkbox"/>		Construction – Scheduling Coordinator
<input type="checkbox"/>		Construction – Scheduling Coordinator
<input type="checkbox"/>		District Construction Engineer
<input type="checkbox"/>		District Engineer
<input type="checkbox"/>		District Project Delivery Engineer
		Environmental Project Management Supervisor
<input type="checkbox"/>		Environmental Project Manager
<input type="checkbox"/>		Hazmat, Air & Noise Coord
<input type="checkbox"/>		Hydraulics & Environmental (invite NDNDOT.PCM@NEBRASKA.GOV)
		Hydraulics
		Hydraulics & Environmental ADE
<input type="checkbox"/>		Materials & Research
<input type="checkbox"/>		NEPA Specialist (EDU - Enviro Documents Unit Analyst)
<input type="checkbox"/>		Program Management Coordinator

<input type="checkbox"/>		Railroad Liaison
<input type="checkbox"/>		Right of Way
<input type="checkbox"/>		Roadway Design Consultant(s)
<input type="checkbox"/>		Roadway Designer (or Consultant Coordinator)
<input type="checkbox"/>		Roadway Design Section Head
<input type="checkbox"/>		Roadway Design Unit Head
<input type="checkbox"/>		Roadside Development Compliance Unit (RDCU)
<input type="checkbox"/>		Section 106 Coordinator
<input type="checkbox"/>		T&E Biologist
<input type="checkbox"/>		Traffic
<input type="checkbox"/>		Utility Coordinator
<input type="checkbox"/>		Utility Engineer
<input type="checkbox"/>		Wetlands/404 Coordinator (Environmental Permits Biologist)

**Optional and Additional Attendees**

<input type="checkbox"/>		Construction
<input type="checkbox"/>		Environmental Program Manager - RDCU
<input type="checkbox"/>		Hwy Civil Rights Coordinator
<input type="checkbox"/>		Traffic Engineering – Asst. Traffic Engineer
<input type="checkbox"/>		Traffic Engineering – Traffic Engineer
<input type="checkbox"/>		
<input type="checkbox"/>		
<input type="checkbox"/>		

**Project Schedule**

*Field visit: date*

*ROW activities present on project?*

*Turn-in Date: date*

*Letting Date: date*

**Project Scope**

Discuss scope of project ( .kmz).

### Updates

Have the project limits changed from the DR73?  
Discuss Project Details or Project Description (updates and questions).

### Bridge

Will there be bridge or bridge-sized box culvert work on the project?

- Bridge work able to be phased?
- Grade change to structure?
  - Will elevation of structure change?
  - Is grade raise due to overlay?
    - Will guardrail need to be adjusted?
- Shoring needed?
- Estimated cost differences for each option if possible (Example: alternative structure options, changes to Bridge determination (location), phasing or shifting alignment)
- Temporary road (shoo-fly) or detour necessary/preferred?
  - Size of culverts required (and number)
  - Sag elevation of road at channel (or over culvert)
  - Adjacent property conflicts?
  - Grades to build the temporary road too steep for the roadway to be feasible?
- Contractor Access Crossings needed?
  - Work platform required? (access not possible across waterway)
  - What will it be used for? (Ex: Contractor Access or placing girders only)
  - Span lengths, flow – can temp access be constructed with a temporary bridge or is it possible to use culverts?
    - Size of culverts required (and number)
    - Sag elevation of road at channel (or over culvert)
  - Adjacent property conflicts?
  - Grades to access the Contractor's Access Crossing too steep for the crossing to be feasible?
- Allowable lane widths
  - Temporary surfacing needed?
- If there are multiple bridges, how many will be allowed to be under construction at any one time?
- Other Issues/challenges

### Detours/Phasing

Detours (Roadway Design will initiate agreement(s) with Cities and Counties as needed.)

- Hwy Traffic Detour
  - Reason for need
  - District preference for detour route
  - Work or upgrades needed on detour route?
    - Any costs to other party?
  - Signing responsibility? (City, County, State, etc.)
  - Maintenance responsibility?
  - Length of time needed?
  - Restrictions on detour? (Ex: tonnage limit, width restrictions)
  - Night detour needed?
  - Winter detour needed?

- Local Traffic Detour
    - Reason for need (Ex: intersection within temporary signal zone, construction of right-turn lanes)
    - District preference for detour route
    - Work or upgrades needed on detour route?
      - Any costs to other party?
    - Length of time needed?
    - Restrictions on detour? (Ex: tonnage limit, width restrictions, no parking, one-way traffic)
    - Night detour needed?
    - Winter detour needed?
  - Phasing at Interchanges – discuss strategy at these locations:
    - Slip ramps
    - Ramp closures
    - Ramp detours
- 15.1 Will there be minor traffic disruptions requiring detours, temporary roads, or ramp closures that are greater than **30 working days**      Yes    No    N/A
- 15.2 Will there be major traffic disruptions requiring detours, temporary roads, or ramp closures that are greater than **135 working days**      Yes    No    N/A
- 15.4 Urban Detour (population of 5,000 or more)  
Is the detour greater than 10 miles?      Yes      No    N/A  
Describe access provisions for local traffic, if any  
(Ex: sending Truck traffic to alternate route due to turning radius, providing for emergency services)
- Rural Detour  
Is the detour greater than 30 miles?      Yes      No    N/A  
Describe access provisions for local traffic, if any (Ex: sending Truck traffic to alternate route due to turning radius, providing for emergency services)
- 15.9 Are there any measures being taken to avoid, minimize, or offset detours or other traffic impacts? Any commitments to restrict detours? (Ex: schools)  
Yes      No      N/A
- 15.8 Traffic Disruption Comments:  
Temp Closures - # of working days (or closed for first/second construction season).  
Detour during winter?



**Traffic**

- Does Traffic Division consider this to be a Significant Project?
- Number of lanes to remain open during construction.
- Lane width recommendations
- Lane closure restrictions or other traffic related work area restrictions during construction.
- Pedestrian access during construction
- Would temporary signals be needed?
  - Estimated cost
- Permanent Signals
  - Phasing
  - Locations and Footing depths for poles

**Construction**

- Constructability issues to address
  - Inlet reconstruction/adjustment to new grade
  - Modifying cross slope to provide minimum 1.5%
- Special Provisions (anticipated) to include in project PS&E file
- How many construction seasons are anticipated?
- Will winter work be necessary? (culverts, bridge platforms, large tree removal, clearing/grubbing)
- Will night-time work be needed?
- Are there other construction projects in the area that may affect traffic detours or access?
- Will early clearing and grubbing be necessary?

**Right of Way**

- Are property rights (ROW) included in the Clarity schedule?
  - What work requires acquiring ROW?
  - Can ROW be reduced or avoided?
  - Are there any anticipated easements or ROW needed at known cultural resource sites or Section 4(f) properties (parks, trails, etc.)?
- 1.1 Will temporary easements be needed? Yes No
- 1.2 Will permanent ROW or easements be needed? Yes No
- 1.3 Will there be a need to acquire greater than 4 acres per linear mile (estimated) or remove major property improvements? Yes No
- 1.5 Estimated acres of permanent ROW and easements:
- 1.6 Estimated acres of temporary easements:
- 1.7 Will there be any residential or non-residential displacements?  
Yes No

### **Utilities**

Which utility companies are located on the project?

- Water and Sewer
- Electrical – Overhead and underground
- Gas
- Communication
- Others: Irrigation Districts, Pipelines, Natural Resource Districts, etc.
- Are there any major utility conflicts that are expected?
  - For Example – conflict with a water line, access crossing on the same side as a transmission power line, hitting a fiber optic line
  - Can any of these be mitigated?
- Are there NDOT owned utilities on the project (Planning, Traffic, ITS, Lighting)
  - Will these be impacted by the project?
  - How will the conflict be resolved? By NDOT Contractor or by District Forces?
  - What plan sheets and special provisions will be required?
- Will construction activities impact any utilities, either temporarily or permanently?
- Access crossing – on one side or both sides of the highway
  - Are the temporary LOC's shown on the plans?
  - Does the Access Crossing impact utilities, specifically power lines?
  - Will a crane be required that will be in conflict with a power line?
- Are there any manholes and valves that need to be adjusted to grade?
- Will any special provisions be required to accommodate utility relocations?
- Is this project a candidate for including Utility Plans (K Sheets) into the plan set?

### **Railroad**

- Any railroad involvement on project or detour?
  - Will any agreements be needed?

### Lighting

- Upgrading to LED?
  - Estimated cost
- Poles
  - Adding festoons (for power)?
    - Estimated Cost
  - Adding banner brackets?
    - Estimated cost
- If adding new poles, identify locations on aerial map
  - Estimated cost
  - Provide depth of soil disturbance
- If removing poles, identify locations on aerial map
  - Estimated cost
  - Provide depth of soil disturbance
- Will temporary power be needed?
  - Who is responsible for coordinating the power (contractor or District)?
- Any agreements needed?
  - Cost sharing?
    - PE?
    - CE?
- High Mast Towers present?
  - “Use in Place” or replace (High Mast or Conventional)?
  - Estimated cost

### Local Events/Festivities

- 15.5 Does the project have temporary or permanent interference with local special events or festivals? Yes No N/A

### Impacts to Businesses

- 15.6 Does the project have a temporary or permanent adverse effect to through-traffic dependent businesses? Yes No N/A
- 16.1 Access Disruptions - Will the project require any access closures to businesses? Yes No N/A
- 16.4 Will the project result in **closure of business** access during operational hours? Yes No N/A

### Impacts to Residences

- 16.1 Access Disruptions - Will the project require any closures to any residences? Yes No N/A
- 16.2 Will project result in complete closure to residential properties for: greater than 5 working days? Yes No N/A
- 16.3 Will project result in complete closure to residential properties for: greater than 10 working days? Yes No N/A

**Emergency Services** (Fire, Ambulance, Hospital, Health clinic etc.)

- 16.5 Will the project restrict access to emergency service facilities or providers?  
Yes No N/A

**Traffic Change or Disruption**

- 15.7 Will the project result in a substantial permanent traffic pattern change or disruption? (Permanently closing a roadway or roadway intersection, increase through lane capacity, create new intersections, convert a roadway into a higher classification roadway)?  
Yes No N/A

**Functionality of Adjacent Properties**

- 16.6 Will the project permanently change the functionality of adjacent properties? (Truck turning movements, etc.)?  
Yes No N/A

**Project Development (Roundtable led by NDOT Resource Specialists)**

- Section 404 Wetland/Stream Impacts
  - Quantify Wetland Impacts
  - Wetland Mitigation Strategy
  - Wetland Permitting Strategy
- National Wild and Scenic River or National Recreational River
- USACE Levees, Dams, Civil Works Projects Present – Section 408
- Floodplain and Drainage
- Section 9 – Coast Guard Permit
- Threatened & Endangered Species
- Section 106 (Historic)
- Hazmat, Noise & Air
- Section 4(f) (park, recreational lands, wildlife, waterfowl refuges, historic sites)
- Environmental Justice – minority/low income populations
- Public Involvement – what is Public Information plan for project?
- Program Management (identify critical path and changes in schedule)
  - Any change needed for the PS&E and/or letting dates?
- Roadside Stabilization
- MS4
  - Mitigation
    - What mitigation will be located on project?
    - Location

### Closing

- Will there be a need for an additional field visit (PIH)?  
(Date of PIH Report should be no sooner than date of this meeting.)
- Project Details & Description documents  
– any changes/follow-up needed based off this meeting?
- Will a “Change Control Form” be needed for any changes discussed in this meeting?
  - Thresholds (prior to PCM 35) from NDOT Super Team’s “Criteria that elevates project to discuss with CCAM” include:
    - Total project changes +/- \$1M or 20% of project total (whichever is less)
    - If the project is at risk for missing the intended construction season
    - Project length change +/- ¼ mile
    - Change in design standard (Maintenance, 3R, New and Reconstruction)
    - Change bridge strategy from “Use in Place” to “Repair/Rehab/Replace”
    - Addition or removal of the need to acquire ROW (add or remove entire phase)
    - Addition or removal of Railroad activities

### Action Items



**PROJECT COORDINATION MEETING 35**  
**PHASE 3 AT END OF DESIGN PHASE:**

**WHEN MEETING OCCURS:**

- At the end of Phase 3 Design Phase
- After the PIH Report (Final Scope Report) has been distributed.
- Prior to Public Involvement Action in Phase 4

**INFORMATION NEEDED AND HAS BEEN COMPLETED/COLLECTED:**

- Protected Population Evaluation (HR)
- District Program Evaluation – Cumulative Impacts (PSPM)
- Final Public Involvement Plan (Communications)
- Final Pavement Determination (M&R)
- Final Scope Report (RD)
- Final Bridge Datasheet (Bridge)
- Required Contract Provisions (CE Section 20)

**PURPOSE OF MEETING:**

- Confirm that there are no significant impacts resulting from reasonably foreseeable effects of the project (NEPA)???
- Confirm Probable Class of NEPA action and if project is assignable
- Review Draft NEPA Document - unofficially
- Review Final Scope Report
- Determine if ROW Acquisition will utilize Federal Aid (If so, then PCM 50 will be required and NEPA document needs to be approved prior to ROW Acquisition)

**WHAT TO PROVIDE AT MEETING:**

- Updated DR290 (OnBase – RD)
- Updated LOCs (Google .kmz file – RD)
- Final Scope Report (OnBase – RD)
- Updated Public Involvement Plan (Communications)
- Updated T&E Checklist (OnBase – RD)

**ATTENDEES:**

- Bridge Management Engineer
- Bridge Hydraulics Engineer
- District Representative
- Roadway Design Section Head (Optional)
- Roadway Design Engineer Unit Head
- Roadway Design Engineer/Designer
- Roadway Design Hydraulics Engineer
- Roadway Design Environmental Liaison Engineer
- Roadway Design Utilities Unit Head
- Roadway Design Utilities Coordinator
- Project Scheduling Program Management Coordinator
- Public Involvement Coordinator
- Environmental Section Manager (Optional)
- Environmental Permits Unit Manager
- Environmental Permits Unit Coordinator
- Environmental Documents Unit Manager
- Environmental Documents Unit Coordinator
- Roadside Stabilization Unit Erosion Control Designer
- Threatened & Endangered Species Biologist
- Hazmat, Air & Noise Coordinator
- Section 106/Historic Coordinator



**Project Coordination Meeting 35** (Clarity Task5331)  
(Conduct at the End of Phase 3 After Plan-in-Hand,  
Design Phase)

Proj No.:	Proj Name:			Control No.:	Date:
Designer: <input type="checkbox"/>	EPU Biologist: <input type="checkbox"/>	EDU Analyst: <input type="checkbox"/>	Next Meeting:		
T&E Biologist: <input type="checkbox"/>	Section 106 Coordinator: <input type="checkbox"/>	Hazmat, Air & Noise: <input type="checkbox"/>	District Representative: <input type="checkbox"/>		
Design Unit Head: <input type="checkbox"/>	Bridge: <input type="checkbox"/>	Bridge Hydraulics: <input type="checkbox"/>	PSPM: <input type="checkbox"/>		
PS&E: <input type="checkbox"/>	Letting: <input type="checkbox"/>	Environmental Project Manager: <input type="checkbox"/>	RDC: <input type="checkbox"/>		
Public Involvement: <input type="checkbox"/>	ROW: <input type="checkbox"/>	Utilities Unit Head: <input type="checkbox"/>	Utilities Coordinator: <input type="checkbox"/>		

**Other Attendees:**

**Information Provided:** \*Information needed prior to scheduling the PCM 35

- Final DR290 (OnBase)\*
- Final LOCs (Google .kmz file – RD)
- Final Scope (PIH) Report (OnBase)\*
- Updated Public Involvement Plan (Communications)
- Updated T&E Checklist (OnBase – RD)
- LOC's to ROW\*

**Meeting Agenda:**

- Review known/anticipated environmental commitments
- Review changes from PCM 30 and since the PIH
- Review Plan in Hand Report (Changes, Special Investigations, Special Provisions)
- PSPM Coordinator will identify critical path, risks and concerns (Fiscal Constraints, LTRP, Agreements, etc.)
- Utilities (Known conflicts, agreements, relocations, fed aid eligible)
- Railroad (Status of Review, Agreement, Specials, etc.)
- Action Items may include Super Team discussion thresholds and Change Control Forms.
- Determine if a PCM 50 is needed
  - Phase-ability, changes, Changes to Project Description, Significant lag from PCM 35 to PCM 70 (>1 year)
- Confirm that there are no significant impacts resulting from reasonably foreseeable effects of the project (NEPA)???
- Confirm Probable Class of NEPA action and if project is assignable
- Review Draft NEPA Document – unofficially
- Determine if ROW Acquisition will utilize Federal Aid (If so, then PCM 50 will be required and NEPA document needs to be approved prior to ROW Acquisition) (PSPM)

NEPA: Click here to enter text.

**Summarize Threshold Impacts (Refer to Threshold Summary Spreadsheet for Levels):**

- Highway Capacity Changes:
- Right-of-Way Required:
- National Wild and Scenic River or National Recreational River:
- Floodplain     Floodway:
- Section 404 Wetland / Stream Impacts:
- Section 408 - Levees, reservoirs, civil works projects Present:
- Section 9 – Coast Guard Permit:
- Threatened & Endangered Species:
- Section 106 (Historic):
- Hazmat, Noise & Air:
- Section 4f (Park, recreational lands, wildlife, waterfowl refuges, historic sites):
- Traffic Disruptions (Temporary Road, Detour or Ramp Closure):
- Property Access
- Railroad:
- Environmental Justice – Minority / Low Income Populations:
- Public Involvement:

---

**Previous Action Items:**

**Summary of Project Description:**

---

**Notes:**

---

**Action Items:**

**PROJECT COORDINATION MEETING 50**  
**END OF PHASE 3 PRIOR TO COMPLETION OF THE NEPA**  
**DOCUMENT:**



**Project Coordination Meeting 50 (Clarity Task)—**  
*(Conduct at the End of Phase 3 Prior to Completion of the NEPA Document)*

Proj No.:	Proj Name:			Control No.:	Date:
Designer: <input type="checkbox"/>	EPU Biologist: <input type="checkbox"/>	EDU Analyst: <input type="checkbox"/>	Next Meeting:		
T&E Biologist: <input type="checkbox"/>	Section 106 Coordinator: <input type="checkbox"/>	Hazmat, Air & Noise: <input type="checkbox"/>	District Representative: <input type="checkbox"/>		
Design Unit Head: <input type="checkbox"/>	Bridge: <input type="checkbox"/>	Bridge Hydraulics: <input type="checkbox"/>	PSPM: <input type="checkbox"/>		
PS&E:	Letting:	Environmental Project Manager: <input type="checkbox"/>	RDC: <input type="checkbox"/>		
Public Involvement: <input type="checkbox"/>	ROW: <input type="checkbox"/>	Utilities Unit Head: <input type="checkbox"/>	Utilities Coordinator: <input type="checkbox"/>		

**Other Attendees:**

**Information Provided:**

- Required Design Modifications from Meeting 35
- Appraisal Plans completed
- Cost estimate update 45
- NEPA Completed (if Federal Funds used in ROW Acquisition)
- Letting Date Changes after PCM 35
- Time between PCM 35 and 70 > 1 year
- Requested by Super Team

**Meeting Agenda:**

- Review Environmental Commitments, including reevaluations
- Review changes since PCM 35 (Change Control Forms)
- ROW changes
- Outstanding action items since PCM 35
- Critical path impacts

NEPA:

**Summarize Threshold Impacts (Refer to Threshold Summary Spreadsheet for Levels):**

- Highway Capacity Changes:
- Right-of-Way Required:
- National Wild and Scenic River or National Recreational River:
- Floodplain  Floodway:
- Section 404 Wetland / Stream Impacts:
- Section 408 - Levees, reservoirs, civil works projects Present:
- Section 9 – Coast Guard Permit:
- Threatened & Endangered Species:
- Section 106 (Historic):
- Hazmat, Noise & Air:

- Section 4f (Park, recreational lands, wildlife, waterfowl refuges, historic sites):
- Traffic Disruptions (Temporary Road, Detour or Ramp Closure):
- Property Access
- Environmental Justice – Minority / Low Income Populations:
- Public Involvement:

---

Previous Action Items:

Summary of Project Description:

---

Notes:

---

Action Items:

**PROJECT COORDINATION MEETING 70**  
**PHASE 7 NEPA VALIDATION:**

**WHEN MEETING OCCURS:**

- After NEPA Approval     After ROW Acquisition
- Designer/Engineer has incorporated right-of-way changes into the plans.
- Prior to PS&E Turn-in

**INFORMATION NEEDED AND HAS BEEN COMPLETED/COLLECTED:**

- ROW Acquisition
- Changes from ROW negotiation(s) and acquisition(s) have been incorporated into plans.
- Verify that the questions on the Approved NEPA Document were answered correctly

**PURPOSE OF MEETING:**

- Review plans to ensure that changes to project due to ROW negotiation and acquisition have been incorporated.
- Confirm that restricted areas are denoted on plans before PS&E Turn-in (e.g. detours, ROW, staging areas, access, protected areas, and concrete cleanout)
- Verify that Plans, Special Provisions, and NEPA document reflect environmental commitments made in the Green Sheet.
- To review Final Scoping Report and confirm the plans reflect the final projectscope
- Assist Environmental Section in completing "Environmental Certification"
  - Confirm that project beginning and ending and limits of construction are consistent with the NEPA document
  - To verify that the 404 permit/floodplain permit is correct and confirm that the 2W sheets have wetland delineation layers shown.
  - Verify Structure numbers match NEPA document
  - Directives for nighttime or daytime construction/lighting, historic properties (if any), tree preservation
  - Easements are shown
  - Confirm threatened and endangered species commitments are in the NEPA document
  - Confirm permits needed and received (404, Stormwater, Floodplain)
  - Confirm that NEPA commitments made it into the Green Sheet

**WHAT TO PROVIDE AT MEETING:**

- PS&E Plans (OnBase – RD)
- Signed NEPA Document (OnBase – EPU)
- Green Sheet (OnBase – EDU)

**ATTENDEES:**

- Roadway Design Section Head (Optional)
- Roadway Design Engineer Unit Head
- Roadway Design Engineer/Designer
- Roadway Design Environmental Liaison Engineer
- Roadway Design Utilities Unit Head
- Roadway Design Utilities Coordinator
- Environmental Section Manager (Optional)
- Environmental Permits Unit Manager
- Environmental Permits Unit – Coordinator
- Environmental Documents Unit Manager
- Environmental Documents Unit – Coordinator
- Roadside Stabilization Unit Erosion Control Designer



**Project Coordination Meeting 70** (Clarity Task 5770)  
(Conduct during Phase 7, Plan Package Phase)

Project No.:	Project Name:		Control No.:	Date:
Designer: <input type="checkbox"/> Click here to enter text.	Design Unit Head: <input type="checkbox"/> Choose an item.	Bridge: <input type="checkbox"/>	Bridge Hydraulics: <input type="checkbox"/>	
Wetland Biologist: <input type="checkbox"/> Choose an item.	EDU Analyst: <input type="checkbox"/> Choose an item.	T&E Biologist: <input type="checkbox"/> Choose an item.	Section 106 Coord: <input type="checkbox"/> Choose an item.	
RDCU: <input type="checkbox"/> Choose an item.	Hazmat, Air & Noise: <input type="checkbox"/> Choose an item.	PSPM: <input type="checkbox"/> Choose an item.	Environmental Project Manager: <input type="checkbox"/> Choose an item.	
District Representative: <input type="checkbox"/> Choose an item.	PS&E:	Letting:	Next Meeting: NA	

**Other Attendees:**

**Information Provided:**

- PS&E Plans (OnBase – RD)
- Signed NEPA Document (OnBase – TRU)
- Green Sheet (OnBase – EDU)

**Previous Action Items (from PCM 35 or 50):**

-

**Meeting Agenda:**

- Confirm Previous Action Items have been resolved. (Designer, Environmental & Others)

- Confirm PS&E Plans reflect latest Project Description and Project Details document. (Designer)

- Confirm changes to project due to ROW negotiation and acquisition are incorporated into PS&E Plans. (Designer & ROW)

- New ROW and Easements Lines are shown in PS&E Plans.
- ROW Certificate is Complete.

- Confirm restricted and avoidance areas are denoted on PS&E Plans (e.g., detours, ROW, staging areas, access, protected areas, sensitive areas-do not disturb, and concrete cleanout). (Designer & Environmental)

- Historic Properties (106 Coord)
- Tree Preservation (T&E Biologist)
- Nighttime or Daytime construction (Designer)

- Confirm, if applicable, PS&E Plan Title Sheet has Stormwater BMP note for MS4 areas. (Only for projects within MS4 areas with stormwater treatment.) (Designer & RDCU)

- Confirm, if applicable, on-site wetland mitigation design is included in PS&E Plans. (Designer & Wetlands Biologist)

- Confirm that project footprint (project limits or construction beginnings and ends) shown in PS&E Plans are within the limits identified in the NEPA document. (EDU Analyst)

- Confirm that Bridge Structure Numbers on PS&E Plans match NEPA document (EDU Analyst & Designer)

- Confirm that all permits needed are obtained (e.g., 408, 404, Floodplain, Stormwater) (RD Hydraulics, Wetlands Biologist, & RDCU)

- Confirm project design commitments within the approved NEPA document have been completed/met, and when applicable, included/met in the PS&E Plans and Special Provisions. (Designer & Environmental)

- Confirm that all NEPA commitments made it into the Green Sheet (EDU Analyst)

- 
- Confirm that required Agreements (Railroad, Utility, Municipality) are complete. (Designer)

- 
- Confirm that Project is ready for turn-in to PS&E, and estimated time frame for turn-in. (All, Designer)

---

**Additional Notes:**

- 
-

---

**Action Items:**

- 
-

**Project Coordination Meeting 70 SFO (Clarity Task5770)**  
*(Conduct during Phase 7, Plan Package Phase)*

Proj No.:	Proj Name:			Control No.:	Date:
Designer: <input type="checkbox"/>	EPU Biologist: <input type="checkbox"/>	EDU Analyst: <input type="checkbox"/>	Next Meeting:		
T&E Biologist: <input type="checkbox"/>	Section 106 Coordinator: <input type="checkbox"/>	Hazmat, Air & Noise: <input type="checkbox"/>	District Representative: <input type="checkbox"/>		
Design Unit Head: <input type="checkbox"/>	Bridge: <input type="checkbox"/>	Bridge Hydraulics: <input type="checkbox"/>	PSPM: <input type="checkbox"/>		
PS&E:	Letting:	Environmental Project Manager: <input type="checkbox"/>	RDC: <input type="checkbox"/>		
		Utilities Unit Head: <input type="checkbox"/>	Utilities Coordinator: <input type="checkbox"/>		

**Other Attendees:**

---

**Information Provided:**

- PS&E Plans (OnBase – RD)
- Green Sheet (OnBase – EDU)

---

**Meeting Agenda:**

- Plans reflect final project scope. (Designer)
  - Changes to project due to ROW negotiation and acquisition are incorporated into plans. (Designer)
    - ROW Certificate Complete
  - Restricted and avoidance areas are consistently denoted on plans before PS&E Turn-in (e.g., detours, ROW, staging areas, access, protected areas, sensitive areas-do not disturb, and concrete cleanout). (Designer)
  - Plans and Special Provisions reflect environmental commitments made in the Green Sheet. (Designer/EDU Analyst)
    - Assist Environmental Section in completing “Environmental Certification”**
    - Confirm that the 404 permit/floodplain permit is correct and confirm that the E sheets have wetland delineation layers shown (EPU Biologist)
    - Confirm that plans include applicable directives for nighttime or daytime construction / lighting, historic properties (if any), tree preservation (EDU Analyst, 106 Coord, T&E Biologist)
    - Confirm that all Easements are shown in plans (Designer/EDU Analyst)
    - Confirm that all permits needed are obtained (e.g., 404, Floodplain, Stormwater) (EPU Biologist, RDC)
    - Confirm that Plan Title Sheet has Stormwater STF note for MS4 areas (Designer)
    - Agreements Complete (Railroad, Utility, Municipality)
-

Notes:

---

Action Items:

## PIH Report & PQS Memo Floodplain Wording

**(6.1) Based on the condition that applies to the project, select the applicable PQS statement from the following (This description will address whether the scope of the project will occur within the boundaries of a mapped base floodplain or a mapped regulatory floodway):**

### **MAPPED COMMUNITIES**

**Condition 1. Review of Floodplain Mapping shows that the project is located in a Mapped and Participating Community and crosses or overlaps upon Base Floodplains.**

PQS Statement: (6.1) Review of floodplain mapping shows that the project overlaps upon one or more Base Floodplains. Certification(s) will be required from the Roadway Design Hydraulics Section and/or the Bridge Hydraulics Section confirming that the project conforms to floodplain regulations. Certifications will be forwarded to the Environmental Permits Unit for inclusion in a Permit Application.

**Condition 2. Review of Floodplain Mapping shows that the project is located in a Mapped and Participating Community and crosses or overlaps upon Base Floodplains and Regulatory Floodways. Check with Roadway Design Hydraulics or Bridge Hydraulics Section to confirm whether Statement A or Statement B (below) is applicable.**

***Use only the statement that applies:***

PQS Statement A (Typically use this statement when there is no channel or bridge work which changes the roadway profile, the conveyance capacity of the bridge or channel, *and* no roadway work which changes vertical or horizontal alignment or the existing roadway prism.):

(6.1) Review of floodplain mapping shows that the project overlaps upon one or more designated Regulatory Floodways and Base Floodplains. Based on the current scope of work the project will be designed to assure that no increase in a Regulatory Floodway's Base Flood Elevation occurs. All certifications required from the Roadway Design Hydraulics Section and/or the Bridge Hydraulics Section confirming that the project meets floodplain regulations will be forwarded to the Environmental Permits Unit for inclusion in a Permit Application. Any change in project scope will be communicated to the Hydraulics Section(s).

***or***

PQS Statement B (Typically use this statement when Statement A condition does not apply.):

(6.1) Review of floodplain mapping shows that the project overlaps upon one or more designated Regulatory Floodways and Base Floodplains. Roadway Design Hydraulics Section and/or the Bridge Hydraulics Section will do a hydraulic investigation to determine the effect of the project on the Regulatory Floodway's Base Flood Elevation. Depending on results of the analysis, the Hydraulics Section(s) will either certify that the current scope of the project conforms to floodplain regulations, work with Roadway Design to modify the project to conform to regulations, or pursue a floodplain map revision. It is unknown at this time whether or not a map revision will be required. All certifications required from the Hydraulics Section(s) confirming that the project meets floodplain regulations will be forwarded to the Environmental Permits Unit for inclusion in a Permit Application. Any change in project scope will be communicated to the Hydraulics Section(s).

**Condition 3. Review of Floodplain Mapping shows that the project is located in a Mapped and Participating Community and does not overlap upon any Base Floodplain or Regulatory Floodway.**

PQS Statement: (6.1) Review of floodplain mapping shows that the project does not overlap upon a Base Floodplain or Regulatory Floodway.

**Condition 4. Review of Floodplain Mapping shows that the project is located in a Mapped but Non-Participating Community and crosses or overlaps upon Base Floodplains.**

PQS Statement: (6.1) Review of floodplain mapping shows that the project overlaps upon one or more Base Floodplains in a non-participating community. Certification(s) will be required from the Roadway Design Hydraulics Section and/or the Bridge Hydraulics Section confirming that the project conforms to floodplain regulations. Certifications will be forwarded to the Environmental Permits Unit for record retention. A Permit is not required.

#### **NON-MAPPED COMMUNITIES**

**Condition 5. Review of Floodplain Mapping shows that the project is in a Non-Mapped and Non-Participating Community and crosses or overlaps upon Potential Base Floodplains.**

PQS Statement: (6.1) The project is located in a non-participating community with no floodplain mapping; State Minimum Standards apply. Review of topographic mapping shows that the project overlaps upon one or more Potential Base Floodplains. Certification(s) will be required from the Roadway Design Hydraulics Section and/or the Bridge Hydraulics Section confirming that the project conforms to floodplain regulations. Certifications will be forwarded to the Environmental Permits Unit for record retention. A Permit is not required.

**Condition 6. Review of Floodplain Mapping shows that the project is in a Non-Mapped and Non-Participating Community and does not overlap upon a Potential Base Floodplains.**

PQS Statement: (6.1) The project is located in a non-participating community with no floodplain mapping; State Minimum Standards apply. Review of topographic mapping shows that the project does not overlap upon a Potential Base Floodplain. This project does not require a floodplain certification or permit.

#### **BY EXPLICIT PERMISSION OF THE ROADWAY HYDRAULICS ENGINEER ONLY**

**Condition 7. Review of Project Scope and Plans shows that the project work Does Not Meet the Criteria for Development.**

PQS Statement: (6.1) Review of the project scope, project description and Plan-In-Hand Plans by the Roadway Design Hydraulics Engineer indicates that the project work has no potential to impact the Base Floodplains/Regulatory Floodways it might cross, and does not meet the criteria for Development within a base floodplain/regulatory floodway. Certification will not be required from the Roadway Design Hydraulics Section or the Bridge Hydraulics Section. A Permit is not required.

**(6.2) Based on the project scope, select the applicable PQS statement that describes whether the project will cause a rise in the Base Flood Elevation (BFE) greater than 1-foot, an increase in the potential for property loss and hazard to life, or any rise in a regulatory floodway from the following:**

PQS Statement (6.2) It is anticipated that this project will be certified to meet floodplain regulations. It is not anticipated to cause greater than one foot of rise in the Base Flood Elevation within a Base Floodplain, any rise in the Base Flood Elevation within a Regulatory Floodway, nor increase the potential for property loss and hazard to life.

Or for Condition 3 only:

PQS Statement (6.2) No floodplain certification or permit is required for this project.

For projects that will require a map revision from FEMA (These projects are few):

PQS Statement: (6.2) It is anticipated that the project will require a conditional letter of map revision (CLOMR) and a letter of map revision (LOMR) following construction and will require further coordination with FEMA. Notify the NDOT Public Involvement Unit.

**(6.3) Does the project have a base floodplain that overlaps the project at locations other than culverts and/or bridges? Determine whether the project scope results in a floodplain encroachment other than functionally dependent uses (e.g. bridges, culverts, wetlands) or actions that facilitate open space use (e.g. recreational trails, bicycle and pedestrian paths).**

Functionally dependent use has been described as bridges, or any water conveyance structures or actions that facilitate the use of open space use (e.g. recreational trails, bicycle and pedestrian paths). Functionally dependent uses also include culverts, grading and guardrails, and other associated or required work that are required to support or protect the bridge or culvert.

PQS Statement – Yes: There are locations along the project that overlap a base floodplain and are not functionally dependent. The following floodplain NFIP/FHBM maps were reviewed: Panel # Dated ####/###/##.

PQS Statement – No: There are no locations along the project that possibly or potentially overlap a base floodplain outside of culverts and bridges, or other activities listed above. All overlapping areas are located at culverts or bridges and are considered a functionally dependent use of the base floodplain. The following floodplain NFIP/FHBM maps were reviewed: Panel # Dated ####/###/##.

PQS Statement – Not Applicable: There are no base floodplains that overlap the project. The following floodplain NFIP/FHBM maps were reviewed: Panel # Dated ####/###/##.

**23 CFR Section 650.111 (b) Location studies shall include evaluation and discussion of the practicability of alternatives to any longitudinal encroachments.**

A. Is the entire project located on existing alignment?

- Option 1 – No longitudinal (parallel) encroachments

PQS Statement – There are no longitudinal (parallel) encroachments located along the project.

- Option 2 – Location(s) parallel to base floodplain, but no overlap

PQS Statement – There are location(s) in which the highway runs parallel to the base floodplain but the project scope does not overlap the base floodplain.

- Option 3 – Longitudinal (parallel) encroachments exist.

PQS Statement – There is or are longitudinal (parallel) encroachments located along the project, which are described as follows: [Describe this or these locations]. Based on the scope of work on alignment, there would be no reasonable and practicable alternative(s) to this longitudinal encroachment.

B. Is the project or any portion of the project location on new alignment?

- For reconstruction or new construction on any portion of the project on new alignment, include a paragraph regarding the alternative analysis and selection of the alignment.

- *Describe Alternative Analysis and final decision*

**23 CFR Section 650.111 (c) Location studies shall include discussion of the following items, commensurate with the significance of the risk or environmental impact, for all alternatives containing encroachments and for those actions which would support base floodplain development.**

**1) The risks associated with implementation of the action:**

- Do the alternatives containing encroachments increase the potential for loss of life or property?
  - No  
PQS Statement – This action would not increase the potential for loss of life or property.
  - Yes  
PQS Statement – This action may increase the potential for loss of life or property. [Describe the increase in the potential for loss of life or property associated with the implementation of the action.]

**2) The impacts on natural and beneficial floodplain values:**

- Do the alternatives containing encroachments impact the natural and beneficial floodplain values?
  - No  
PQS Statement – There are no significant encroachments associated with this Project and this Project will not have an impact on the natural and beneficial floodplain values.
  - Yes  
PQS Statement – This action may impact natural and beneficial floodplain values. [Describe impacts to the natural and beneficial floodplain values.]



**3) The support of probable incompatible floodplain development:**

- Do the alternatives containing encroachments support probable incompatible floodplain development?
  - No  
PQS Statement – The proposed improvements on this Project will maintain local and regional access to existing rural and agricultural areas and will not create new access to undeveloped lands. Therefore, this highway improvement Project will not support probable incompatible floodplain development.
  - Yes  
PQS Statement – This action may support probable incompatible floodplain development. [Describe alternatives containing encroachments that support probable incompatible floodplain development.]

**4) The measures to minimize floodplain impacts associated with the action, and:**

- Discuss measures to minimize floodplain impacts associated with encroachments, commensurate with the significance of the risk or environmental impact.
  - Encroachment results in no/minimal impact on the floodplain.  
PQS Statement – Based on assessment of the significance of the risk or environmental impact, no additional measures are necessary to minimize floodplain impacts associated with the action.
  - Encroachment results in significant impact on the floodplain.  
PQS Statement – Additional measures to minimize floodplain impacts associated with the action are necessary. [Discuss measures to minimize floodplain impacts associated with the action.]

**5) The measures to restore and preserve the natural and beneficial floodplain values impacted by the action:**

- Discuss measures to restore and preserve the natural and beneficial values impacted by the action.
  - PQS Statement – There will be limited impacts to the natural and beneficial floodplain values of the floodplains along this Project. Since there will be temporary soil disturbance during construction activities, sediment and erosion control best management practices will be utilized during construction and disturbed areas will be seeded following construction.

**23 CFR Section 650.111 (d) Location studies shall include evaluation and discussion of the practicability of alternatives to any significant encroachments or any support of incompatible floodplain development.**

- Does a significant encroachment occur as a result of the project?
  - No  
PQS Statement – There is no significant encroachment. This does not result in a significant potential for interruption or termination of this transportation facility, which is needed for emergency vehicles or a community’s only evacuation route. It also does not result in a significant risk or potential for loss of life or property. This project does not result in a substantial adverse impact on natural and beneficial floodplain values. No discussion of the practicability of alternatives is required.
  - Yes  
PQS Statement – A significant encroachment would occur as a result of the project. [Please evaluate and discuss the practicability of alternatives to any significant encroachment.]
  
- Does the project support incompatible floodplain development?
  - No  
PQS Statement – This highway improvement Project will maintain local and regional access to existing rural and agricultural areas and does not support incompatible floodplain development. No discussion of the practicability of alternatives is required.
  - Yes  
PQS Statement – This action may support incompatible floodplain development. [Describe alternatives containing encroachments that support probable incompatible floodplain development.]

## **DEFINITIONS**

Floodplain Mapping	<p>Flood Hazard Maps (FHM), Flood Hazard Boundary Maps (FHBM) or Flood Insurance Rate Maps (FIRM) accepted by the Federal Emergency Management Agency (FEMA) or created for review and acceptance by FEMA that show Special Flood Hazard Areas (SFHA0) subject to inundation by the 1% Annual Chance Flood (100-yr Flood).</p> <p>Mapping is available at the FEMA Flood Map Service Center web site <a href="https://msc.fema.gov/portal">https://msc.fema.gov/portal</a> or the Nebraska Department of Natural Resources Floodplain Interactive Map <a href="https://dnr.nebraska.gov/floodplain/interactive-maps">https://dnr.nebraska.gov/floodplain/interactive-maps</a></p>
Potential Base Floodplain	<p>A drainage way in a Non-Mapped Community, which has a watershed area of more than 640 acres (one square mile) upstream of the point of interest (usually the highway).</p>
Mapped Community	<p>A Community (County, City or Village) which has Floodplain Mapping (FHM, FHBM, FIRM, or work maps) (see definition above).</p>
Non-Mapped Community	<p>A Community (County, City or Village) which does not have Floodplain Mapping (see definition above). State Minimum Standards apply within these Communities.</p>
Participating Community	<p>A Community (County, City or Village) which is participating in the National Flood Insurance Program (NFIP). A Participating Community regulates development activities, via ordinances and permits, which occur in floodplains (mapped or potential) within in its jurisdiction.</p> <p>A list of Participating Communities is maintained on the FEMA web site <a href="http://www.fema.gov/national-flood-insurance-program/national-flood-insurance-program-community-status-book">http://www.fema.gov/national-flood-insurance-program/national-flood-insurance-program-community-status-book</a></p>
Non-Participating Community	<p>A Community (County, City or Village) which does not participate in the National Flood Insurance Program (NFIP). A non-participating community does not regulate development activities that occur in floodplains (mapped or potential) within in its jurisdiction.</p> <p>A list of Non-Participating Communities is maintained on the FEMA web site <a href="http://www.fema.gov/national-flood-insurance-program/national-flood-insurance-program-community-status-book">http://www.fema.gov/national-flood-insurance-program/national-flood-insurance-program-community-status-book</a></p>
State Minimum Standards (paraphrased)	<p>No construction, improvement or obstruction shall be allowed in the floodplain unless it is demonstrated that the effect of the construction will increase the water surface elevation of the base (100 year) flood for a:</p> <ul style="list-style-type: none"><li>• Base Floodplain - one foot or less (&lt; 1.0 feet), and</li><li>• Regulatory Floodway – no rise (0.00 feet).</li></ul>



## PIH Report Wording for Section 408 and Non-USACE Regulated Dams and/or Reservoirs

**(7.8) Based on the condition that applies to the project, select the applicable PIH statement from the following:**

**Section 408 – USACE regulated dams, levees, or other civil works projects – Choose one from the following three conditions:**

**Condition 1. No USACE regulated levee, dam and/or other civil works project was identified within 500 feet of the project’s ROW or its construction limits.**

PIH Statement: (7.8) No Section 408 coordination is required between NDOT and USACE for this project. No USACE regulated levee, dam and/or other civil works project was identified within 500 feet of the project’s ROW or its construction limits.

**Condition 2. USACE regulated levee(s), dam(s) and/or other civil works project(s) were identified within 500 feet of the project’s ROW or its construction limits. The project scope will not alter, occupy, or use the USACE regulated levee(s), dam(s) and/or civil works project(s).**

PIH Statement: (7.8) No Section 408 coordination will be completed between NDOT and USACE for this project. USACE regulated levee(s), dam(s) and/or other civil works project(s) were identified within 500 feet of the project’s ROW or its construction limits. The project scope will not alter, occupy, or use the USACE regulated levee(s), dam(s) and/or civil works project(s). USACE regulated levees, dams, and other civil works projects will be denoted as “Sensitive Areas” on the project plans to avoid activity within those areas.

**Condition 3. USACE regulated levee(s), dam(s) and/or other civil works projects were identified within 500 feet of the project’s ROW or its construction limits. Project work will alter, occupy, or use the USACE regulated levee(s), dam(s) and/or other civil works project(s).**

PIH Statement: (7.8) Coordination is required between NDOT and USACE to obtain 408 permission for the project. The proposed project scope will alter, occupy, or use USACE regulated levee(s), dam(s) and/or other civil works project(s).

**Non-USACE Regulated Dam(s) and/or Reservoir(s) (State or other Federally Regulated Dams)**

**Select an additional condition for non-USACE regulated dam(s) and/or reservoir(s) that will capture other federally owned or state regulated dams or reservoirs which would require coordination with agencies other than the USACE. For example, other federal agencies include, but are not limited to, United States Bureau of Reclamation (USBR) or Natural Resources Conservation Service (NRCS). State regulated dams are regulated by Nebraska Department of Natural Resources (NeDNR).**

**Condition 1. No non-USACE federally regulated dams and/or reservoirs were identified within 500 feet of the project's ROW or its construction limits.**

PIH Statement: No coordination is required between NDOT and NeDNR and/or non-USACE federal agency and/or the dam owner to obtain concurrence for the project work. No state or non-USACE regulated dams or reservoirs were identified within 500 feet of the project's ROW or its construction limits.

**Condition 2. A non-USACE regulated dam and/or reservoir is located within the project's ROW or its construction limits.**

PIH Statement: There is a state regulated dam or reservoir located within the project's ROW. Coordination is required between NDOT, NeDNR and the dam owner for the project work.

1. GLOSSARY

A. Acronyms, Abbreviations and Symbols

3C	Continuing, Cooperative, Comprehensive planning process
3R	Resurfacing, Restoration and Rehabilitation projects
AASHTO	<b>American Association of State Highway and Transportation Officials</b>
ADA	Americans with Disabilities Act
AADT	Annual Average Daily Traffic
ADT	Average Daily Traffic
ARMS	Automated Right-of-Way Management System
BCT	Breakaway Cable Terminals
CA	Certification Acceptance Program Agreement
CADD	Computer-Aided Drafting and Design
CE	Categorical Exclusion
CERCLA	Comprehensive Environmental Response, Compensation and Liability Act
CRT	Controlled Releasing Terminals
DA	Drainage Area
DDI	Diverging Diamond Interchange
DEA	Draft Environmental Assessment
DEIS	Draft Environmental Impact Statement
DDHV	Directional Design Hourly Volume
DHV	Design Hourly Volume
EA	Environmental Assessment
EIS	Environmental Impact Statement
EPA	<b>Environmental Protection Agency</b>
ESAL	Equivalent Single Axle Load
e	Superelevation rate
$e_{max}$	Maximum superelevation rate
f	Side friction factor
$f_{max}$	Limiting side friction factor
FAA	<b>Federal Aviation Administration</b>
FEMA	<b>Federal Emergency Management Agency</b>
FHWA	<b>Federal Highway Administration</b>
FONSI	Finding Of No Significant Impact

---

<b>H rating</b>	<b>AASHTO</b> bridge live load rating corresponding to weight of a two-axle truck or lane loading (a uniformly distributed and concentrated load)
<b>HS Rating</b>	<b>AASHTO</b> bridge live load rating representing a tractor truck with semitrailer, or the corresponding lane loading
<b>HSIP</b>	Highway Safety Improvement Program
<b>HW</b>	Headwater
<b>IES</b>	<b>Illuminating Engineering Society</b>
<b>IJR</b>	Interchange Justification Report
<b>IMR</b>	Interchange Modification Report
<b>K</b>	Rate of vertical curvature, the length of vertical curve per percentage change in the algebraic difference between two tangent grades
<b>L</b>	Length of curve, distance from the PC to PT along a curve
<b>L<sub>r</sub></b>	Superelevation runoff length
<b>L<sub>min</sub></b>	Minimum superelevation runoff length
<b>MELT</b>	Modified Eccentric Loader Terminals
<b>MGS</b>	Midwest Guardrail System
<b>mph</b>	Miles per hour
<b>MPO</b>	Metropolitan Planning Organization
<b>MSE</b>	Mechanically Stabilized Earth
<b>MUTCD</b>	The <u>Manual of Uniform Traffic Control Devices</u>
<b>NC</b>	Normal Crown section
<b>NCHRP</b>	<b>National Cooperative Highway Research Program</b>
<b>NDEQ</b>	<b>Nebraska Department of Environmental Quality</b>
<b>NDOT</b>	<b>Nebraska Department of Transportation</b>
<b>NDOT Form 73</b>	Highway Improvement Planning Request Form
<b>NDOT Form 335</b>	Design Decision Document Sheet
<b>NDOT Form 342</b>	Project Information Sheet
<b>NEPA</b>	National Environmental Policy Act
<b>NFIP</b>	National Flood Insurance Program
<b>NHPP</b>	National Highway Performance Program
<b>NWP</b>	Nationwide Permits
<b>OI</b>	Nebraska Department of Transportation Operating Instruction
<b>OSHA</b>	<b>Occupational Safety and Health Administration</b>
<b>P</b>	Any point on a curve
<b>P<sub>o</sub></b>	The high or low point of the curve
<b>PC</b>	Point of Curvature for a horizontal curve
<b>PCC</b>	Point of Compound Curvature
<b>PI</b>	Point of Intersection of tangents for a horizontal curve



---

PRC	Point of Reverse Curvature
PS&E	<b>Plans, Specifications and Estimates Section</b> in the <b>Construction Division</b>
PSI	Pavement Serviceability Index
PSS	Preconstruction Scheduling System
PT	Point of Tangency for a horizontal curve
PVC	Point of Curvature for a Vertical curve
PVI	Point of Intersection of tangents for a Vertical curve
PVT	Point of Tangency for a Vertical curve
Q	Culvert capacity
Q <sub>design</sub>	Overtopping frequency or the frequency based on the allowable water surface elevation, whichever is more critical
R	Radius of a horizontal curve
R-*	Right-of-way plan sheets
RBP	<b>FHWA Risk Based Project</b>
RCRA	Resource Conservation and Recovery Act
ROW	Right-of-Way
RR	Railroad
RRZ	Rail Highway Crossings Program
SCS	<b>Soil Conservation Service</b>
SEE	Social, Economic and Environmental review
SHPO	<b>State Historic Preservation Officer</b>
SPUI	Single Point Urban Interchange
STBG	Surface Transportation Block Grant Program
STP	Surface Transportation Program
STIP	Statewide Transportation Improvement Program
T	Tangent length, distance from PC or PT to PI
TCP	Traffic Control Plan
TR	Tangent runout length
TRB	<b>Transportation Research Board</b>
TWLTL	Two-Way Left Turn Lane
USDOT	<b>United States Department of Transportation</b>
USGS	<b>U.S. Geologic Survey</b>
VC	Vertical Curves
VPD	Vehicles Per Day
X-*	Roadway cross-section sheets

**B. Terms and Definitions**

<b>Abandonment</b>	The act of abandoning an existing roadway and right-of-way when the road is not needed on the state highway system.
<b>Access</b>	A means of ingress or egress between a highway and abutting property or an intersecting local public road or street.
<b>Access Control</b>	Restriction of the number and location of access points along the highway; it varies by the functional classification of the roadway.
<b>Accessibility</b>	A measure of the ability of users to utilize the transportation system.
<b>Adjusted Embankment</b>	The volume of embankment that results from the balance factor being multiplied by the measured embankment.
<b>Alignment Book</b>	A construction book that provides a listing of alignment information for referencing and relocating the centerline.
<b>Allocation</b>	Assigning funds to particular uses.
<b>Ambient Air Quality</b>	The quality of the surrounding air measured in terms of presence of ozone, hydrocarbons, nitrogen oxide, and carbon monoxide based on national standards.
<b>Annual General Stormwater Runoff Permit</b>	A permit obtained annually by the <b>Construction Division</b> relative to stormwater discharge.
<b>Archeological Resources</b>	Prehistoric cultural assets.
<b>Armor Coat</b>	A surface treatment consisting of sequential applications of asphalt and stone chips which may be made either in one or more layers to build up a structure roughly one inch or more in thickness.
<b>Arterial Highway</b>	Defined by <b>AASHTO</b> as “A highway primarily for through traffic, usually on a continuous route.”
<b>At-Grade Intersections</b>	Locations where two or more roadways or entrances cross and/or meet each other at the same elevation.
<b>Auxiliary Lanes</b>	Lanes that are not considered through travel lanes that are intended for use by vehicular traffic for specific functions, such as left and right turns, climbing/passing, acceleration/deceleration, weaving, etc.
<b>Annual Average Daily Traffic</b>	The average traffic volume in both directions on a highway segment for one year, divided by the number of days in the year.
<b>Average Daily Traffic</b>	The average 24 hr. traffic volume in both directions collected over a number of days greater than one but less than a year.
<b>Backslope</b>	A cut slope, the segment of the roadside geometry that slopes up from the outside edge of a ditch to intersect with the existing ground.

---

<b>Balance</b>	When the amount of available excavation equals the amount of needed embankment.
<b>Balance Points</b>	A location along a roadway where an earthwork balance occurs.
<b>Balance Factors</b>	Multipliers applied to embankment volumes to adjust for shrinkage or swell of the soils used for embankment.
<b>Barrier</b>	A structure used to protect traffic from hazardous conditions along the roadside or medians.
<b>Barrier Curb</b>	Steep-face curb design to inhibit encroachment on state right-of-way.
<b>Base Course</b>	The layer or layers of specified or selected material of designed thickness placed on a subbase or a subgrade to support a pavement surface course.
<b>Benefit-Cost Comparison</b>	An economic evaluation to determine if a given design is warranted and justified based on the costs and benefits associated with it.
<b>Bid</b>	A contractor's written offer to construct a project based on the contract documents (plans, specifications, special provisions, etc.) at a specified price.
<b>Blue Top Book</b>	A construction book that provides a format for finish stake (blue top) notes to be recorded. Stations and subgrade elevations at the centerline, edge of surface and edge of subgrade shoulder are the information provided.
<b>Borrow</b>	Additional material required when the amount of embankment needed exceeds the amount of excavation available.
<b>Borrow Pit</b>	Areas that are approved by the state for the source of borrow; they can be either contractor-furnished or state-furnished.
<b>Borrow Restoration</b>	Upon completion of removal of borrow from a site, the pit is to be scarified and then stockpiled topsoil replaced and seeded.
<b>Breakaway Support</b>	A support used for traffic signs, traffic signals, streetlights, etc. that is designed to breakaway or bend on impact with an errant vehicle.
<b>Bridge</b>	A structure for carrying traffic erected over a depression or an obstruction and having an opening greater than 20 feet as measured along the centerline of the roadway.
<b>Bridge Approach Section</b>	A transition section from guardrail to a bridge rail.
<b>Broken Back Curve</b>	A curve consisting of two consecutive curves deflecting in the same direction joined by a short tangent section.
<b>Budgeting</b>	The process of outlining future funding needs based on anticipated highway projects.

---

<b>Buffer Strip</b>	Defined by <b>AASHTO</b> as “An area providing a degree of protection from certain highway or transportation effects for adjacent private property or protected natural resources.”
<b>Bullnose Guardrail</b>	A guardrail configuration in which the guardrail is curved around a hazard, forming a “nose”. It is often used in medians to shield a hazard from traffic in both directions.
<b>Cable Guardrail</b>	Guardrail constructed of multiple steel cables stretched between support posts.
<b>CADD Coordination Policy</b>	A schedule of required drafting activities for roadway design.
<b>Capacity</b>	The maximum flow in vehicles per hour that can be reasonably expected on a segment of highway during a given time period under prevailing roadway, traffic and control conditions.
<b>Capacity Analysis</b>	Study that estimates the amount of traffic that can be accommodated by a given facility while maintaining a predetermined level of service.
<b>Categorical Exclusion</b>	An environmental classification for a project indicating that no significant environmental impacts are anticipated (Class II project).
<b>Center Of Gravity</b>	The location where a vertical line divides an area of cut or fill into two equal areas; the area left of the center of gravity equals the area right of the center of gravity.
<b>Center Pivot</b>	A structure that pumps water from the ground to an aerial sprinkler system that rotates about the structure; used for crop irrigation.
<b>Changes In Concept</b>	Alterations in the original project idea during the planning and/or design stages.
<b>Changes In Scope</b>	Modifications in the extent or size of the project.
<b>Change Order</b>	A written order to the contractor covering changes in the contract.
<b>Channelization</b>	The physical separation of vehicular and/or pedestrian traffic movements to regulate conflicting movements.
<b>Channelized Intersection</b>	An intersection at which various traffic movements are separated by auxiliary lanes, medians, islands, etc.
<b>Clarity</b>	A computerized system that programs, schedules and monitors projects through preconstruction stages. The <b>Project Scheduling Section</b> of the <b>Program Management Division</b> manages it.
<b>Class I Project</b>	A project that may significantly impact the environment and for which an environmental impact statement is required.
<b>Class II Project</b>	A project that has been determined will not significantly affect the environment.

---

<b>Class III Project</b>	A project on which the environmental impact must be determined and for which an environmental assessment must be prepared.
<b>Clean Air Act</b>	A federal law passed to protect and enhance the quality of the nation's air resources.
<b>Clean Water Act</b>	A federal law passed in 1977 to protect the quality of the nation's water resources.
<b>Clear Zone</b>	<b>AASHTO</b> defines the clear zone as "that portion of the roadside that is free of obstructions and sufficiently flat to enable an errant vehicle to encroach without overturning. The clear zone width at any point along the roadway is measured from the edge of the traveled way to the nearest obstruction or the beginning of a non-traversable slope. Thus, shoulders are part of the roadside clear zone."
<b>Climbing Lanes</b>	Additional lane(s) provided on crest vertical curves to accommodate slow moving vehicles.
<b>Cloverleaf Interchange</b>	Four-leg interchanges with loop ramps to accommodate left turn movements. A full cloverleaf has loops in all quadrants.
<b>Collector-Distributor Roads</b>	An auxiliary road system parallel to but separate from a freeway/interstate that collects and distributes local traffic with the intent of limiting the number of entrance and exit points on a freeway while satisfying the demand for access to the freeway. Similar to frontage roads but collector-distributor roads do not provide access to abutting properties.
<b>Comfort Criteria</b>	Design consideration of motorists' willingness and/or ability to accept discomfort while traversing a roadway.
<b>Complex Interchanges</b>	A combination of two or more interchange configurations, within very limited spacing, connecting several different roadways.
<b>Compound Curve</b>	Two curves which join on the same side of a common tangent with no tangent length between the curves.
<b>Comprehensive Plan</b>	A plan developed for a local, regional or statewide area that considers social, economic, cultural, transportation, environment, and other concerns.
<b>Condemnation</b>	A legal proceeding <b>NDOT</b> pursues when an agreement cannot be reached with a landowner on the purchase of right-of-way.
<b>Consolidation</b>	The settling of existing ground under the weight of embankment, causing the embankment to settle.
<b>Construction Joint</b>	A joint made necessary by a prolonged interruption in the placing of concrete.

---

<b>Construction Sequencing</b>	The construction of a roadway in different phases so that the project may be built while maintaining through traffic and/or access to local residences or businesses.
<b>Contaminated Soils</b>	Soil that has unacceptable impurities in it.
<b>Contour Grading Plans</b>	Plans that show proposed contour lines for the areas adjacent to the roadway surfaces for use in construction.
<b>Contract Plans</b>	Plans used to bid on and construct a project.
<b>Contraction Joint</b>	A joint normally placed at recurrent intervals in a rigid slab to control transverse cracking.
<b>Controlled Access Facility</b>	A facility designed for through traffic and upon which <b>NDOT</b> may regulate, restrict or prohibit access for efficient traffic flow and the reduction of areas of traffic conflict.
<b>Corridor Protection</b>	A procedure whereby <b>NDOT</b> notifies appropriate local governmental agencies and the general public of the intent to acquire right-of-way along a highway corridor in order to restrict the amount of development which may occur adjacent to the intended improvement minimizing acquisition costs and design complexity.
<b>Corridor Protection Plans</b>	Plans, often aerial sheets, filed with the local government showing property ownership and the corridor width to be protected.
<b>Corridor Studies</b>	Studies of projects that may involve some relocation and/or community bypass. Study results usually are published in report form and include alignment location factors and cost estimates. Plan and profile sheets may also be included.
<b>Cost Estimate</b>	The anticipated cost of a project at different stages of planning and design.
<b>Cost Sharing</b>	The division of project expenses among governmental (and possibly other) entities involved in the project.
<b>Covenant Agreement</b>	A written agreement or contract between the state and local cities, towns or villages that outlines the respective responsibilities in planning, designing, constructing or maintaining a highway or their associated facilities, such as roadway lighting, traffic signals, etc.
<b>Covenant Relinquishment Agreements</b>	Agreements prepared prior to public hearings in which the provisions of relinquishment of roadway maintenance and operation functions to a local government are described.
<b>Crash Cushions</b>	A protective system that prevents errant vehicles from impacting roadside obstacles by decelerating the vehicle to a stop when the cushion is hit head on or redirecting the vehicle away from the obstacle when the cushions are hit from the side.

---

<b>Critical Length Of Grade</b>	The maximum length of a designated upgrade on which a loaded truck can operate without an unreasonable reduction in speed.
<b>Critical Path</b>	Tasks and activities that must be completed prior to the start of other activities.
<b>Critical Slope</b>	A slope that is considered non-recoverable, non-traversable and one on which a vehicle is likely to overturn. A slope steeper than 1:3.
<b>Cross Slope (Roadway)</b>	The slope across traffic lanes and shoulders perpendicular to the flow of traffic.
<b>Crossover</b>	Temporary pavement constructed on divided highways to temporarily route traffic across the median to the opposite lanes so that construction can occur on the vacated side.
<b>Crowned Typical Section</b>	A cross-section of roadway that has the high point of the pavement located at the center of the traveled way and slopes to both shoulders.
<b>Cul-De-Sacs</b>	A turning area provided at the closed end of a street opened at one end only.
<b>Culvert</b>	A structure under the roadway with a clear opening of less than 20 feet as measured along the center of the roadway.
<b>Curb Cut</b>	A depression in the curb that is provided at curb ramps and entrances.
<b>Cut Slope</b>	A positive grade side-slope generally going upward and outward from the shoulder edge or ditch bottom to intersect the natural ground.
<b>Daylighting</b>	Flattening the roadway backslope to intersect with the natural ground at a lower elevation than the typical backslope. This is done to gain excavation or to improve sight distance.
<b>Decision Sight Distance</b>	The distance required for a driver to complete the following actions: 1) detect an unexpected or otherwise difficult-to-perceive information source or obstacle in a roadway environment; 2) recognize the obstacle or its threat potential; 3) select an appropriate speed and path; and 4) initiate and complete the required maneuver.
<b>Deed</b>	A signed legal document to convey or transfer rights, ownership, etc.
<b>Delineators</b>	Retroreflective devices mounted at the side of the roadway used to guide traffic, especially at night.
<b>Depressed Median</b>	A median that is constructed at a lower elevation than the travel lanes. They are typically used on freeways and other divided arterials.

---

<b>Design Checklist</b>	A list of tasks associated with roadway design activities.
<b>Directional Design Hourly Volume</b>	The design hourly volume in number of vehicles travelling in one direction during the thirtieth highest hour for the design year.
<b>Design Hourly Volume</b>	The design hourly volume in number of vehicles travelling in both directions during the thirtieth highest hour for the design year.
<b>Design Process Outline</b>	An outline of regular roadway design activities.
<b>Design Relaxation or Exception</b>	A deviation from the design standards requiring approval by the appropriate state and/or federal officials.
<b>Design Speed</b>	The maximum speed that can be maintained over a specified section of highway when conditions are so favorable that the design features of the highway govern. Limits of curvature, sight distance, roadway clearance, maximum gradient and other geometric features are a function of design speed.
<b>Design Vehicle</b>	A theoretical motor vehicle whose weight, dimensions and operating characteristics are used to establish highway design controls such as radius returns and turning roadways.
<b>Design Year</b>	The year 20 years after the initial construction for New and Reconstructed projects and for 3R projects.
<b>Detour</b>	A signed alternate route within an existing roadway system that guides traffic around a construction zone outside of the project right-of-way instead of through the construction zone.
<b>Diamond Interchange</b>	A simple interchange with four ramps configured similarly to a diamond and having a stop condition on the side road.
<b>Directional Island</b>	Raised, flush or painted medians used to guide and protect traffic during turning movements. Also, known as channeling islands.
<b>Directional Interchange</b>	An interchange that provides continuous high-speed free-flow operations for both through and turning movements.
<b>Distribution Analysis</b>	An analysis of the volumes of excavation and embankment by station for the purpose of determining if the project earthwork will be balanced, borrow or waste.
<b>Diverging Diamond Interchange</b>	An interchange configuration that shifts left turning traffic to the opposite side of the road at two signalized intersections.
<b>Dowel</b>	A load transfer device in a rigid slab, usually consisting of a plain round steel bar.
<b>Driver Expectancy</b>	A drivers' memory of previous roadway experiences that he/she relies on when responding to new situations.
<b>Driveways</b>	Access openings to adjoining properties from roadways.
<b>Dry Run</b>	Rehearsal for public hearing.



---

<b>Easement</b>	A legal right afforded a person, agency, etc. to make limited use of another's land usually for specific purposes, such as construction, utility, access, etc. Easements may be permanent or temporary.
<b>Embankment</b>	Material that must be filled or placed to construct the proposed roadway and its associated components.
<b>Embankment Foundation Report</b>	A report by the <b>Soils Mechanics Unit</b> recommending steps to minimize settlement and slope stability problems in areas of poor foundation soils.
<b>End Areas</b>	The areas of cut and fill computed between cross-sections from which total volumes of embankment and excavation may be made for the entire project.
<b>Endangered Species</b>	A species that is in danger of extinction throughout all or any portion of its range.
<b>Endangered Species Act</b>	A federal law passed in 1973 to insure that actions authorized, funded or carried out by state or federal agencies do not jeopardize, destroy or critically modify the continued existence of endangered or threatened species and their habitat.
<b>Engineering Review</b>	A process by the <b>Project Development Division Location Studies Section</b> early in the project to establish the concept of work to be performed and the initial itemized cost estimate for major, non-interstate projects. The review summarizes the existing highway conditions, traffic, classification, adjacent sections, alignment, and environmental conditions. It is sometimes completed by the <b>Roadway Design Division</b> for smaller projects.
<b>Enhancement Projects</b>	Transportation infrastructure projects by local, regional and state governments that are not eligible for funding from other programs, e.g., historic preservation, trails and scenic byways projects.
<b>Entrance Ramp</b>	A ramp that provides access onto an expressway or interstate.
<b>Environmental Assessment</b>	A study required for environmental Class III projects for which the significance of environmental effects of a proposed project must be determined. If it is determined that the project will have no significant environmental impacts, it remains a Class III project and a finding of no significant impact (FONSI) statement is prepared. If significant effects are possible, the project is reclassified as a Class I project.
<b>Environmental Classification</b>	Federal designation of a project based on its potential impact on the environment.
<b>Environmental Impacts</b>	The possible effects of projects on the quality of the social, cultural or natural environment.
<b>Environmental Impact Statement</b>	A statement that describes the anticipated social, economic and environmental impacts of a Class I project (projects that may have significant impact on the environment).

---

<b>Environmental Summary Sheet</b>	A form from the <b>Project Development Division</b> that outlines the measures to be taken to mitigate the effects of a project on the environment, the applicable permits, etc.
<b>Equivalent Single Axle Loads</b>	Summation of equivalent 18,000-pound single axle loads used to combine mixed traffic to design pavement for traffic in the design period.
<b>Erosion</b>	A process in which soil and/or rock is loosened from its resting place and is carried by wind and/or runoff and deposited elsewhere.
<b>Erosion Control</b>	A program to control the displacement of soil particles by water, wind or other agents.
<b>Erosion Control Permit</b>	A part of the Section 404 permit process related to controlling water and siltation due to runoff into any water body including wetlands.
<b>Established Quantities</b>	Quantities of earthwork material determined from cross-sections by Design and used for the payment of earthwork.
<b>Estimate Checklist</b>	A listing of items required for a cost estimate.
<b>Excavation</b>	Material that must be cut to construct the proposed roadway, ditches, channels, entrances, etc.
<b>Exempt Projects</b>	Projects exempt from <b>FHWA</b> oversight.
<b>Exit Ramp</b>	A ramp that provides egress from an expressway or interstate.
<b>Expansion Joint</b>	A joint located to provide for the expansion of a rigid slab, without damage to itself, adjacent slabs or structures.
<b>Exposure Factor</b>	A factor used to evaluate whether grade separation of a railroad/roadway crossing is necessary based on the number of vehicles times the number of trains per day. If this factor is 50,000 or greater, a grade separation should be considered.
<b>Expressway</b>	A divided highway for through traffic with full or partial control of access with interchanges at major intersections and at-grade intersections at designated minor public road intersections. It serves urban centers of 15,000 population or more not served by the Interstate System.
<b>Federal Aid Projects</b>	Projects that are partially or entirely funded by the federal government. They must comply with federal regulations, including environmental regulations.
<b>Federal Funding</b>	Funds provided by the federal government from various funding appropriation sources for transportation-related projects. Depending on the appropriation restrictions, some portions of projects may be participating (federal funds may be used for those items) or nonparticipating (items are not eligible for those particular federal funds).
<b>Fill Slope</b>	A downward embankment slope connecting the graded shoulder at the hinge point to the ditch bottom or natural ground.

---

<b>Final Plans</b>	Contract plans used by contractors, inspectors, etc. to construct the project. Final Plans are issued by <b>Construction</b> .
<b>Flare Rate</b>	The allowable variable offset distance of a barrier to move the barrier end further from the traveled way.
<b>Floodplain</b>	The area adjoining a watercourse or drainage way that has been or may be covered by floodwaters.
<b>Floodway</b>	The channel of a watercourse or drainage way and the adjacent land areas that must be reserved in order to discharge the base flood without cumulatively increasing the water surface elevation more than a reasonable height.
<b>Flush Median</b>	A median that is on the same plane as the travel lanes, it is usually delineated by paint stripping on the pavement.
<b>Fog Seal</b>	A surface application of dilute emulsion with no aggregate that seals the pavement surface and generally provides a very distinct delineation between the mainline pavement and the shoulder.
<b>Foreslope</b>	The segment of the roadway cross-section from the hinge point sloping downward to the inside edge of the ditch.
<b>Foundation Course</b>	The graded portion of a highway prepared as the foundation for the pavement structure and shoulder.
<b>Foundation Report</b>	A report that summarizes field investigations of foundation soils and makes recommendations to minimize settlement and slope stability problems.
<b>Freeway</b>	An arterial highway with full control of access.
<b>Frontage Roads</b>	Restricted access roads, paralleling the mainline, to maintain capacity on the mainline and provide access to adjoining property.
<b>Functional Classification</b>	The grouping of highways and roads by the primary service they provide, access, mobility or a combination of access and mobility. It is used to determine the design standards to be used.
<b>Functional Design</b>	The stage of design after the plan-in-hand inspection and prior to the public hearing.
<b>Future Access</b>	A future means of ingress or egress between a highway and abutting property or an intersecting local public road or street that will not be built by <b>NDOT</b> but will be built by the owner at some future date when the development of the property requires construction of the driveway.
<b>Gore</b>	The area between a through roadway and an exit/entrance ramp.
<b>Gore Neutral Area</b>	The triangular area between the gore nose and the physical nose and the triangular area between the physical nose and the painted nose.

---

<b>Gore Nose</b>	A point, having some dimensional width separating the shoulders of the through traveled way and the ramp, upstream from the gore area.
<b>Grade Separation</b>	The separation of traffic at an intersection of two or more roadways by constructing the roadways at different elevations; provides for free flow of traffic on all highways through the intersection but does not provide for access for turning traffic.
<b>Granular Subdrain</b>	A drain that is constructed of a porous, granular material designed to drain water from the foundation of the pavement.
<b>Guardrail</b>	A longitudinal barrier that shields roadside hazards from vehicles that may leave the traveled way.
<b>Habitat</b>	The place(s) a given species of animal or plant naturally lives or grows that has the necessary food, cover, water and other species-specific conditions essential to well-being.
<b>Haul</b>	The distance that excavated material is moved, as shown on the plans, from the location where the material is obtained to the location where the material is to be deposited.
<b>Headwater</b>	The depth of water impounded upstream of a culvert due to the influence of the culvert construction, friction and configuration.
<b>Height Of Eye</b>	The height of driver's eye above the road surface used for calculating sight distances. For stopping and passing sight distances, passenger vehicle height of eye is 3.5 feet.
<b>Height Of Object</b>	The height of an object within the roadway used for calculating sight distances.
<b>Highway Commission Statement</b>	An official communication from <b>Roadway Design</b> to the <b>Highway Commission</b> regarding a proposed project.
<b>High-Speed Roadway</b>	A roadway with a design speed $\geq 50$ mph
<b>Hinge Point</b>	The point where the rate of slope either continues at 1:6 or changes to a steeper slope based on the difference in elevation between the edge of the finished shoulder and the end of the foreslope.
<b>Horizontal Alignment</b>	The line of roadway curvature as related to the horizontal direction.
<b>Horizontal Sight Distance</b>	The clearance required from the center of the inside lane to an obstruction located off the pavement area on the inside of a horizontal curve. The straight-line distance a driver can look through a horizontal curve to the road ahead.
<b>Impact Attenuators</b>	Barriers designed to act as cushions, absorbing most of the energy from errant vehicles that leave the roadway before striking a roadside hazard.

<b>Intelligent Transportation Systems</b>	“Intelligent Transportation Systems ( <b>ITS</b> ) is a combination of electronics, telecommunications, and information technology to the transportation sector for improving safety and travel times on the transportation system. It is not highways only but includes all modes of transportation.” (Source: Michigan DOT)
<b>Inertial Barriers</b>	Impact attenuators that are modules filled with sand used for protection of poles, column bases, lighting supports, etc.
<b>Intercepting Dikes</b>	Small dikes constructed at the top of cut slopes that prevent stormwater from flowing down the cut slopes by intercepting the runoff and redirecting the flow to where it can be discharged into a ditch, creek, stream, etc.
<b>Interchange</b>	A combination of ramps and grade separations designed to increase capacity, reduce or eliminate traffic conflicts, and reduce the potential for crashes at the junction of two or more roadways. They separate the through traffic movements and also provide for turning traffic movements.
<b>Interchange Justification Report</b>	The justification and documentation required by the <b>FHWA</b> to substantiate any proposed changes in access to the Interstate System. The IJR will focus on the technical feasibility of the proposed access; the social, economic, and environmental impacts will be addressed in the NEPA review.
<b>Interchange Modification Report</b>	The justification and documentation required by the <b>FHWA</b> to substantiate any proposed modifications in existing access to the Interstate System. The IMR will focus on the technical feasibility of the proposed access. Reconstruction or major modifications to existing interchanges that do not involve adding roadway capacity may be eligible for classification as a Categorical Exclusion.
<b>Intergovernmental Agreements</b>	Agreements prepared by the <b>Agreements Section</b> in the <b>Project Development Division</b> that outline the scope and participation of the governmental parties involved in a project and are executed for projects involving other units of government.
<b>Intersection Sight Distance</b>	The unobstructed sight distance along both road approaches at an intersection and across their included corners for a distance that will allow vehicle operators, approaching simultaneously, to see each other in time to prevent collisions.
<b>Interstate</b>	A national defense highway system established to connect most cities of 50,000 or more population in the U.S., with complete access control and a minimum of two 12 feet wide lanes in each direction, divided in most instances by wide medians.
<b>Interval</b>	A discrete portion of a traffic signal cycle during which signal indications do not change.
<b>Island</b>	A flush or raised channelizing device.

---

<b>Joint Access</b>	A single access provided to two or more properties.
<b>Land Water Conservation Fund Act</b>	An act administered by the <b>National Park Service</b> to preserve public parklands. The Act provides funds to purchase and develop public parklands, and to preserve those lands from conversion to other uses.
<b>Landscaping</b>	Plantings, scenic view development, retaining walls, median treatments, slope rounding or berms, aesthetic treatment, etc. for environmental, functional or aesthetic purposes.
<b>Lane Balance</b>	A condition in which there is a balance in the number of traffic lanes on a freeway and the number of lanes on ramps to provide for efficient traffic operations through and beyond interchanges. The number of lanes and the rate that lanes are added and dropped at interchanges are appropriate for the interchange.
<b>Lateral Extent Of Hazard</b>	The distance from the edge of the traveled way to the far side of a hazard, if the hazard is a fixed object, or to the outside edge of the clear zone if the hazard is an embankment or fixed object that extends beyond the clear zone.
<b>Level Of Service</b>	A rating system from A to F that classifies roads or highways according to the operating conditions of the roadway given the design traffic volumes, A being a roadway providing an optimum level of service and F being a roadway providing a very poor level of service. The operating conditions that characterize levels of service are described in terms of density, average travel speeds, volume to capacity ratios, and stop delays at intersections.
<b>Life Cycle Cost Analysis</b>	The economic analysis of pavement design alternatives based on initial construction costs, maintenance costs, salvage values at the end of the life of the pavement and replacement costs.
<b>Limits Of Construction Plans</b>	Design plans, developed after the public hearing, showing the extent of the area required for the construction of the project. They include culverts, driveways, intersections, dikes, etc. for use in right-of-way design.
<b>Living Snow Fence</b>	A barrier of trees and shrubs planted to reduce snow drifting along a highway, usually at or near the right-of-way line.
<b>Load Transfer Device</b>	Devices, e.g., steel dowel bars, used at transverse joints to properly distribute load stresses without offering resistance to longitudinal movement at the joint.
<b>Local Roads</b>	Rural roads not classified otherwise except minimum maintenance roads.
<b>Location Studies</b>	Studies to address social, economic, environmental and other issues associated with alternative project locations for specific "spot" projects or for longer corridors.
<b>Longitudinal Slope</b>	The slope of the travel lane along the length of the travel lane.

---

<b>Longitudinal Joint</b>	A joint normally placed between traffic lanes in rigid pavements to control longitudinal cracking.
<b>Loop</b>	A curved ramp that has a less direct travel path and distance than normal ramps and often will redirect the path of a vehicle almost 290°.
<b>Low-Speed Roadway</b>	A roadway with a design speed $\leq 45$ mph
<b>Lump Sum Funding Splits</b>	A method of allocating funds from several funding sources by dividing the total costs on a pro rata basis.
<b>Mailbox Turnout</b>	A designated area, outside the travel lanes, provided for the use of vehicles accessing mailboxes.
<b>Major Arterials</b>	Roadways linking cities, towns and other traffic generators, that are capable of carrying long distance travel and form a network with higher systems to provide interstate and inter-county service.
<b>Major Collectors</b>	Roadways that serve the dual function of property access and feeding arterials; they generally consist of shorter trip lengths.
<b>Markings</b>	Traffic control devices, such as pavement markings, object markings or delineators, used to channelize traffic into proper lane position on the roadway. They may either supplement regulatory and warning signs or independently warn or regulate traffic.
<b>Mass Diagram</b>	A graphical representation of the amount of embankment and excavation on a project and the way in which the earth is to be moved. It shows balance point locations, direction of haul and amounts of earth taken from or to each location.
<b>Mass Ordinate</b>	The cumulative algebraic sums of volumes of cut and fill by station.
<b>Medians</b>	The portion of a divided highway separating the traveled ways for traffic in opposite directions.
<b>Median Barrier</b>	A longitudinal barrier placed on the left side of traffic lanes of a divided highway designed to redirect vehicles striking either side of the barrier.
<b>Median Openings</b>	A gap in a median provided for crossing and turning traffic.
<b>Median Width</b>	The distance between the inside edges of the inside travel lanes of a multi-lane divided highway.
<b>Metropolitan Planning Organization (MPO)</b>	Transportation planning organization composed of state and local government officials and citizens responsible for continuing, cooperative and comprehensive planning process in metropolitan areas.
<b>Milling</b>	A process in which asphalt is removed from the roadway by a machine that “scrapes” off the top layer of asphalt.
<b>Minimum Maintenance Roads</b>	Rural roads used occasionally by limited numbers of people as alternative access roads.

---

<b>Maintenance Resurfacing Standards</b>	Maintenance for each functional classification of roadway type as established by <b>the Board of Public Roads Classifications and Standards</b> .
<b>Minor Arterials</b>	Routes to provide linkage of cities, towns and other traffic generators, integrating interstate and inter-county service.
<b>Mitigation</b>	Measures taken to offset or minimize the impact of construction on the environment.
<b>Mobilization</b>	The costs associated with startup activities such as movement of personnel, equipment, supplies and other incidentals to the project site.
<b>Moisture Content</b>	The amount of water in the soil which impacts compaction.
<b>Mountable Curb</b>	A curb designed so that errant vehicles can cross them easily.
<b>Mow Strip</b>	A two feet surfaced section between the curb and a turf median or around area inlets.
<b>MSE Wall</b>	A mechanically stabilized earth retaining wall of blocks or panels.
<b>Multi-Leg Intersections</b>	Intersections having five or more legs.
<b>Municipality</b>	As defined by the Nebraska Revised Statutes, Chapter 13-3203, "Municipality means any county, city, or village in this state."
<b>National Highway System</b>	An interconnected system of principal arterial routes which will serve major population centers, international border crossings, ports, airports, public transportation facilities, other intermodal transportation facilities and other major travel destinations.
<b>National Register Of Historic Places</b>	A federal listing of places with significant historic value.
<b>Nationwide Permits</b>	A type of permit issued by the <b>U.S. Army Corps of Engineers</b> for projects that have minimal environmental impacts.
<b>Needs Assessment</b>	An annual review of the condition of existing roadways throughout the state conducted by the <b>Classification, Needs, and Pavement Management Unit</b> in the <b>Materials and Research Division</b> . A summary of the results are published in the <u>State Highway Inventory Report</u> .
<b>New Jersey Barriers</b>	Concrete rigid barriers generally used as median barriers and as barriers in work zones.
<b>Noise</b>	Unwanted sound.
<b>Noise Abatement</b>	Measures taken to reduce noise through design features or location of a project.
<b>Noise Barriers</b>	Devices installed beyond the Horizontal Clear Zone to reduce the effects of noise on nearby noise sensitive areas.



---

<b>Nonparticipating</b>	That portion of a project that a particular federal fund does not cover, e.g., federal bridge funds may not be used for mainline construction.
<b>Nonpoint Source Pollution</b>	Pollution that cannot be attributed to a specific source.
<b>Non-Recoverable Slope</b>	A slope on which a motorist will not be able to stop his/her vehicle or return to the roadway but generally will reach the bottom of the slope without overturning; a slope between 1:4 and 1:3.
<b>No Passing Zones</b>	Segments of two-lane, two-way highways that do not have sufficient passing sight distance for motorists to pass slower moving vehicles. Pavement markings and warning signs are used to inform drivers of no passing zones.
<b>Object Markers</b>	Traffic control devices that warn motorists of physical obstructions or roadside conditions within or adjacent to the roadway that pose a hazard to motorists. They are considered a maintenance item and are not included in roadway quantities and cost estimates.
<b>Off-Street Parking</b>	A parking facility, parking lot or garage that is provided outside of the roadway right-of-way and is not considered a part of the roadway.
<b>Off-System County Roads</b>	County roads that are not part of the federal or state highway system.
<b>Off-System Rural Projects</b>	Projects on rural roads for which local road standards have been developed.
<b>Off-System Urban Projects</b>	Urban transportation projects in cities of the first class that are eligible for specific federal funding.
<b>On-Street Parking</b>	Parking that is provided adjacent to the traveled way of a roadway within the roadway right-of-way; it is considered a part of the roadway.
<b>Operating Speed</b>	The highest overall speed at which a driver can travel on a given highway under favorable weather conditions and under prevailing traffic conditions without exceeding the design speed on a section-by-section basis.
<b>Outer Separation</b>	The area between the traveled way of a roadway for through traffic and a frontage road or street.
<b>Overlay</b>	The resurfacing of an existing pavement to a specified depth to extend the structural life of the pavement.
<b>Painted Gore Nose</b>	A point, having no dimensional width, occurring at the separation of the pavements at a ramp.
<b>Parallel Fill Slope</b>	A fill slope that parallels the roadway.
<b>Partial Cloverleaf Interchange (Parclo)</b>	A cloverleaf interchange with loops in some but not all quadrants.
<b>Passing Sight Distance</b>	The distance required for an overtaking vehicle to pass another vehicle on a two-lane, two-way roadway.

---

<b>Pavement Markings</b>	Traffic devices in the form of line markings, symbols, arrows, raised reflective markers, etc. that are on the roadway pavement to channelize the traffic and to warn motorists.
<b>Pavement Structure</b>	A combination of subbase, base course and surface course placed on a subgrade to support the traffic load and distribute it to the roadbed.
<b>Pavement Serviceability Index</b>	A numerical value derived by formula from measurements of certain physical features of the pavement.
<b>Pavement Subdrain</b>	Subgrade drainage treatments, which vary depending on the subgrade soils plasticity index.
<b>Pedology</b>	Study of the genesis and classification of soils.
<b>Permanent Easement</b>	A property easement in which <b>NDOT</b> has the use of or access to land that remains in private ownership. The owner may do as he/she chooses with the property as long as it does not conflict with the purpose of the easement.
<b>Phasing</b>	The division of a construction project into several stages over time.
<b>Physical Gore Nose</b>	A point, having a dimensional width separating the pavements, upstream of the gore area.
<b>Pivot Irrigation System</b>	Custom irrigation systems varying in size and configuration that consist of center pivot structure and a boom that holds the sprinkler heads and rotates around the center pivot.
<b>Plan-In-Hand</b>	A field inspection of the proposed project, after preliminary design, by <b>NDOT</b> representatives and others as appropriate.
<b>Planning</b>	Advance consideration, development and description of anticipated projects, activities and scheduling.
<b>Point Of Convergence</b>	The point of intersection of a ramp and the through travel lane.
<b>Posted Speed</b>	The speed limit on advisory signs posted on the roadway; usually the 85th percentile speed.
<b>Preliminary Design</b>	The initial design of a project following the engineering review.
<b>Preliminary Plans</b>	Plans developed prior to preliminary design, from a survey or as-built plans, showing existing features only.
<b>Principal Arterials</b>	Roadways that provide corridor movement with trip length and density compatible with significant statewide or interstate travel.
<b>Priority Commercial System</b>	A roadway designation for routes that carry heavy traffic volumes and/or large volumes of commercial vehicles. The Priority Commercial System consists of the non-Interstate NHS routes and the Expressway System.
<b>Profile</b>	The grade line of a roadway, usually along the roadway centerline.

---

<b>Project Numbering</b>	The assignment of a unique number to a transportation project which identifies the funding source, type of project, and project location.
<b>Public Hearing</b>	A formal process presided over by a <b>Highway Commissioner</b> to present the proposed project to the public and to obtain public input. Hearing guidelines must be followed for notice of hearing, information presented and hearing procedures. The hearing is recorded and a transcript is made of the verbal testimony.
<b>Public Information Meetings</b>	Informal meetings held to inform the public of the proposed project location and/or design, to obtain public input and to answer questions from the public. They are usually held for major relocations and location studies, right-of-way appraisal, design and scope changes and sometimes for engineering review.
<b>Radius Return</b>	The turning radius of an intersection.
<b>Raised Median</b>	A median that is elevated above the travel lanes to control access and left turns on urban highways and streets.
<b>Ramp Angle</b>	The angle the ramp makes with the mainline highway.
<b>Ramps</b>	Any type, arrangement and size of turning roadway that connects two or more legs at an interchange.
<b>Ramp Terminal</b>	The portion of a ramp adjacent to the through traveled way, including speed change lanes, tapers and islands.
<b>Reconstructed Bridges</b>	An existing bridge that is to be either widened, significantly remodeled or rehabilitated.
<b>Recoverable Slope</b>	A slope on which a motorist can stop his/her vehicle or slow it and then return to the roadway; a slope of 1:4 or flatter.
<b>Recovery Taper</b>	The taper downstream of a weaving section that enables motorists to merge with the traffic on the expressway.
<b>Reimbursable Costs</b>	The eligible non-betterment expenditures a utility owner incurs in relocating utilities to accommodate a proposed project.
<b>Relinquishment</b>	A process by which <b>NDOT</b> maintains ownership of right-of-way for utility easement purposes but cedes responsibility for maintenance and operation of the roadway to a local government.
<b>Relocation Assistance</b>	Financial assistance provided to residents and business entities that are relocated due to right-of-way acquisition.
<b>Reverse Curves</b>	Two curves on opposite sides of a common tangent with a relatively short tangent length between the curves.
<b>Right-Of-Way</b>	Land, property or interest therein, usually in strip, dedicated for transportation purposes.

---

<b>Right-Of-Way Appraisal Plans</b>	R.O.W. Ownership plans with the addition of limits of construction, construction details, right-of-way design, permanent and/or temporary easements, access control and summary of areas.
<b>Right-Of-Way Certification</b>	Certificate stating that the right-of-way is available to the contractor and clear of improvements or the estimated date when the non-complying tracts will be clear and available.
<b>Right-Of-Way Costs</b>	Costs associated with acquisition of right-of-way including real property, relocation assistance, fencing, improvements, etc.
<b>Right-Of-Way Marker</b>	A concrete monument, iron pipe, or pin marker used to indicate the location of a highway's right-of-way, where the right-of-way changes width or where a curve in the right-of-way begins or ends.
<b>Right-Of-Way Negotiation Plans</b>	Right-of-way plans that reflect right-of-way contracts and changes made during negotiations.
<b>Right-Of-Way Ownership Plans</b>	Right-of-way plans showing plotted section and quarter section lines, surveyed centerline, topography, property lines, existing R.O.W. boundaries, and ownership data.
<b>Right-Of-Way Survey</b>	A survey conducted to establish section corners, quarter-section corners and lot corners.
<b>Rivers And Harbors Act</b>	A federal act originally passed in 1899 to regulate structures or work affecting navigable waters of the U.S.
<b>Roadside Geometry</b>	The area outside of the hinge points; it is comprised of sideslopes, foreslopes, backslopes, ditch bottoms, benches, etc.
<b>Roadway</b>	<b>AASHTO</b> defines a roadway as "The portion of a highway, including shoulders, for vehicular use. A divided highway has two or more roadways."
<b>Roadway Lighting</b>	Lighting which is provided along a roadway or highway to improve nighttime visibility.
<b>Rollover Rate</b>	The algebraic difference in rate of cross slope between adjacent lanes.
<b>Route Continuity</b>	Providing a continuous through route on which the motorist is not expected to change lanes or "exit" a roadway. Route continuity of minor roadways should yield to preserve road continuity of major roadways.
<b>Running Speed</b>	The actual speed of a vehicle over specified section of highway; the distance traveled divided by the time the vehicle is in motion (running time).
<b>Runout Length</b>	The theoretical distance needed for an errant vehicle that has left the roadway to come to a stop.

---

<b>Rural Area</b>	An area where property abutting the roadway is predominately used for agricultural purposes and lies outside municipal boundaries. It may include isolated tracts devoted to light industrial purposes.
<b>Safe Drinking Water Act</b>	Federal regulations of potable water supply.
<b>Safety Improvement Project</b>	A project that is generally small in size and located at specific high accident sites.
<b>Scenic Byways</b>	A road or byway with roadsides or corridors of aesthetic, cultural or historic value.
<b>Scoping</b>	The initial estimation of project magnitude once a NDOT Form 73 has been initiated.
<b>Section 4(f)</b>	A portion of the 1966 Transportation Act which limits use of publicly owned parks, recreation areas, wildlife/waterfowl refuges, and lands having historic sites of national, state or local significance.
<b>Section 6(f)</b>	A portion of the Land and Water Conservation Fund Act restricting use of public park land funded with Section 6(f) monies.
<b>Section 10 Permits</b>	Permits for construction activity that impacts navigable waterways.
<b>Section 401 Permits</b>	Permits from the <b>Nebraska Dept. of Environmental Quality</b> for activities involving waters of Nebraska, including wetlands. This permit is generally acquired in conjunction with Section 404 individual permits.
<b>Section 402 Permits</b>	Permits required for projects with point source discharge, e.g., rest areas.
<b>Section 404 Permits</b>	Permits from the <b>U.S. Army Corps of Engineers</b> for activities involving waters of the U.S., including wetlands.
<b>Segregation Damages</b>	Damages that may occur to a landowner when property is split by the construction of a highway.
<b>Select Placement</b>	The setting aside of certain excavated soils and/or materials during earthwork construction for a specific placement within the limits of the project. For example, topsoil will often be excavated and separated from other soils for final placement in the top four inches within the construction area.
<b>Semi-Directional Interchange</b>	An interchange that has some high-speed free-flow connections but has one or more connections that are indirect in alignment yet more direct than loops.
<b>Serviceability</b>	The ability, at the time of observation, of a pavement to serve the traffic (autos and trucks) that uses the facility.
<b>Service Interchange</b>	An interchange that transfers traffic between an Interstate or freeway and a lower classification roadway.

---

<b>Service Volumes</b>	The number of vehicles traveling in a lane for a given time period. The number of vehicles “served” by a traffic lane for a given time period.
<b>Shear Lines</b>	Lines used for simplifying earthwork calculations at intersections and other locations where irregularly shaped excavations or embankments may be encountered due to channel changes, etc.
<b>Shop Plans</b>	Plans developed by the contractor to show how the contractor intends to construct specific structures, such as bridges, retaining walls, etc.
<b>Shoulder</b>	The area adjacent to the travel lanes for rural cross-sections or the area behind the curb and gutter for urban cross-sections.
<b>Shrinkage</b>	The decrease in volume of soil when it is excavated, hauled and compacted into an embankment.
<b>Sight Distance</b>	The length of roadway ahead that is visible to the driver.
<b>Signalized Intersection</b>	An intersection where traffic movement is controlled by traffic signals.
<b>Single Axle Load</b>	The total load transmitted by all wheels whose centers may be included between two parallel transverse vertical planes 40 inches apart, extending across the full width of the vehicle.
<b>Single Point Urban Interchange</b>	An interchange configuration where all legs of the interchange intersect at a single point.
<b>Skew Angle</b>	The degree of deviation from a 90° intersection.
<b>Slope Stake Book</b>	A construction notebook that provides elevation and distance information necessary for the construction of back slopes, fore slopes and side slopes.
<b>Slurry Seal</b>	An application of diluted asphalt emulsion mixed with sand-size aggregate and then squeegeed onto the pavement surface. It is generally less than 3/8-inch in depth.
<b>Snowshots</b>	Cut stations where the toe of the backslope is less than 60 feet from the centerline and the backslope elevation is greater than the centerline elevation.
<b>Soil Horizon</b>	The underlying formations of soil layers.
<b>Soil Profile</b>	The combined horizons or layers of soil.
<b>Soil Survey</b>	Research of the soil characteristics and water table condition provided by the <b>Materials and Research Division</b> .
<b>Soil And Situation Report</b>	A report of the results of the soil survey.
<b>Spacing</b>	The number of access locations to the mainline per mile between each mile road or county road.
<b>Special Investigations</b>	Research about specific topics for a proposed project (e.g. accident records, traffic counts).

---

<b>Special Plans</b>	Plans used for items subject to frequent change, e.g., guardrail.
<b>Special Provisions</b>	A document that outlines unique construction items or procedures not covered in the Standard Specifications.
<b>Speed-Change Lane</b>	An auxiliary lane, including taper, used primarily for the acceleration or deceleration of vehicles entering or exiting the through traffic lanes.
<b>Spot Speed Studies</b>	A traffic study that measures the individual speeds of a sample of vehicles passing a given point (spot) on a roadway.
<b>Spread</b>	The width of stormwater from the curb onto the roadway that flows along the pavement.
<b>Stage Construction</b>	The phasing of an entire construction project over several time periods.
<b>Standard Details</b>	Details not large enough to warrant a special plan or standard plan or details of items that are not paid for directly.
<b>Standard Items</b>	Construction and other items, as defined by <b>NDOT</b> that are common project materials or activities.
<b>Standard Plans</b>	Plans that have been developed for common construction items and have been approved by the <b>Standard Plans Committee</b> .
<b>Standard Specifications</b>	The definition and delineation of how activities, materials, etc. are to be provided for <b>NDOT</b> projects.
<b>State-Funded Projects</b>	Projects that are partially or entirely funded by state agencies. They are not required to comply with all federal regulations, but must address environmental concerns.
<b>State Highway Commission</b>	A group of individuals appointed by the <b>Governor</b> to conduct studies, advise the public, and hold public hearings regarding Nebraska highways and the activities of <b>NDOT</b> .
<b>State Highway Inventory Report</b>	A summary of results from the needs assessment.
<b>Station Funding Definition</b>	The identification of limits of funding source coverage by station location.
<b>Stopping Sight Distance</b>	The minimum length of roadway ahead visible to the driver that is long enough to enable a vehicle traveling at or near the design speed to stop before reaching a stationary object in its path. Stopping sight distance is the sum of the distance traversed by the vehicle from the instant the driver sights an object necessitating a stop to the instant that the brakes are applied and the distance required to stop the vehicle from the instant brake application begins.
<b>Storage Area</b>	The portion of a turn lane used for vehicle queuing.
<b>Storage Length</b>	The length of lane needed to store vehicles for a given time period.

---

<b>Structural Snow Fence</b>	Temporary or permanent fencing panels installed along a highway to reduce the snow drifting along a highway.
<b>Subbase</b>	The layer or layers of specified or selected material of designed thickness placed on a subgrade to support a base course (or in the case of rigid pavements, the Portland cement concrete slab).
<b>Subgrade</b>	The top surface of a roadbed on which the pavement structure and shoulders are constructed.
<b>Subgrade Survey</b>	A survey conducted for projects to surface previously graded roads to identify soil sections, stability, and other conditions.
<b>Subgrade And Situation Report</b>	A report issued when there is a period of time between grading and preparation of paving plans. The report describes existing surface conditions, foundation course requirements, existing topography and pedology, drainage, compaction requirements, etc.
<b>Subsidiary Earthwork</b>	Earthwork that is not paid for directly but is included in other earthwork or other construction pay items.
<b>Subsoil</b>	Soils beneath the topsoil that vary in thickness from a few inches to three or more feet. They are characterized by the presence of additional clay and soluble material that has been removed from the topsoil.
<b>Substructure</b>	The part of a structure below the bearings of simple and continuous spans, skewbacks or arches and the top of footings of rigid frames including backwalls, wingwalls, and wing protection railings.
<b>Superelevation</b>	Raising the outer edge of a curve to offset the tendency for vehicles to slip on the outward sloping of a crowned roadway, allowing the driver to maintain average speed through the curve without having to overcorrect steering.
<b>Superelevation Runoff Length</b>	The length of highway needed to accomplish the change in cross slope from a section with adverse crown removed to a fully superelevated section, or vice versa.
<b>Superstructure</b>	The part of a structure above the bearings of simple and continuous spans, skewbacks of arches and top of footings of rigid frames, excluding backwalls, wingwalls and wing protection railings.
<b>Surcharge</b>	The placement of additional embankment on top of a fill to account for settlement or to speed up settlement.
<b>Surcharge Loading</b>	The loading or forces a retaining wall may experience from embankment and traffic.
<b>Surface Transportation Program</b>	A federal funding program which includes public roads not on the NHS and not functionally classified as minor rural collectors or local roads or streets.
<b>Swell</b>	The increase in volume of rock when it is excavated, broken and placed into the embankment.



---

<b>System Interchange</b>	An interchange that transfers traffic from freeway to freeway and/or Interstate to Interstate.
<b>Tangent Runout</b>	The distance required to transition a roadway from a normal crown section to a section with the adverse crown removed, or vice versa.
<b>Tangent Section</b>	A segment of roadway that has a “straight” horizontal alignment with no curvature.
<b>Tangent Typical Section</b>	A cross-section of a roadway that has the high point of the pavement on the inside shoulder and slopes continuously from the inside shoulder to the outside shoulder.
<b>Taper Ramp</b>	A ramp that only consists of a taper either before or after the point of convergence depending on whether it is an exit or entrance ramp, respectively. On taper entrance ramps, acceleration occurs before the point of convergence. On taper exit ramps, deceleration occurs after the point of convergence.
<b>Temporary Easements</b>	Easements that permit the use of private property for a time period not to exceed the duration of the project and for specific purposes such as channel cleanout.
<b>Temporary Road</b>	Temporary detours within the project right-of-way, generally on temporary embankments, to bypass a construction site.
<b>Threatened Species</b>	A species that is likely to become an endangered species within the foreseeable future throughout all or a significant portion of its habitat.
<b>Thrie Beam Guardrail</b>	A roadside barrier system similar to W-beam but with an additional rib in the rail to accommodate a wider range of vehicle sizes.
<b>Tie Bar</b>	A deformed steel bar or connector embedded across a joint in a rigid slab to prevent separation of abutting slabs.
<b>Title</b>	Legal evidence of right to property or the right itself.
<b>Title Research</b>	A search conducted by a right-of-way agent of records for property ownership, existing easements, encumbrances and other interests. Provides information for plotting property lines and identifying ownership.
<b>Toe Of Slope</b>	The intersection of the foreslope with level ground or with a backslope, forming a ditch.
<b>Topsoil</b>	Soil, usually dark in color, that extends from the surface of the ground to a depth of as much as two feet.
<b>Traffic Barrier</b>	<b>AASHTO</b> defines a traffic barrier as” a device used to prevent a vehicle from striking a more severe obstacle or feature located on the roadside. Traffic barriers include roadside barriers, median barriers, bridge railings, and crash cushions.”
<b>Traffic Control Device</b>	A sign, signal, marking or other device on or adjacent to a roadway to regulate, warn or guide traffic.

---

<b>Traffic Control Plan</b>	An essential part of the overall design of the roadway that provides for the routing of traffic through and/or around the construction zone while providing an adequate working area for the contractor.
<b>Traffic Signals</b>	Traffic control devices used to direct conflicting movements of vehicles and/or pedestrians by assigning the right-of-way to various movements at different times.
<b>Transit</b>	A public transportation service.
<b>Transition Length</b>	The distance required transitioning a roadway from a normal crown section to full superelevation. It consists of the tangent runoff and the superelevation runoff length.
<b>Transition Section</b>	A section of roadway that provides a gradual change between different typical cross-sections.
<b>Transverse Contraction Joint</b>	Contraction joints in concrete pavement placed either perpendicular to the centerline with load transfer devices across the joint or skewed from the perpendicular for noise reduction and riding comfort.
<b>Transverse Construction Joint</b>	Joints placed at the end of each day's work or when paving ceases for over 30 minutes. They are placed perpendicular to the centerline.
<b>Transverse Fill Slope</b>	A fill slope that is perpendicular to the roadway and is associated with cross roads, entrances, median crossings or ditch plugs, etc. It is generally more critical to vehicles than parallel fill slopes because errant vehicles tend to run into the transverse slope head on.
<b>Travel Way</b>	<b>AASHTO</b> defines Travel Way as "The portion of roadway for the movement of vehicles, exclusive of shoulders."
<b>Trumpet Interchange</b>	An interchange configuration used where there are only three approaches to be served.
<b>Turning Roadways</b>	Channelized turn lanes at at-grade intersections to provide free flow turn movements.
<b>Unchannelized Intersection</b>	An at-grade intersection consisting of two crossing roadways connected by radius returns, without channelizing devices.
<b>Underdrain Pipe</b>	A pipe in a granular trench, that parallels the edge of pavement and base course, designed to intercept water that gets into the base and subgrade and carry it away from the pavement structure.
<b>Unsuitable Material</b>	Materials (soil, rock, muck, debris, etc.), which are inappropriate for use in the embankment.
<b>Urban Area</b>	A built-up area located adjacent to or within municipal boundaries.

---

<b>Utility</b>	A privately, publicly or cooperatively owned line, facility or system for producing, transmitting or distributing communications, cable television, electricity, light, heat, gas, oil, crude products, water, steam, waste, stormwater not connected with highway drainage, or other similar commodity including a fire or police signal system or street lighting system.
<b>Valley Gutter</b>	A depressed pavement area that is constructed across a side road at an intersection to carry runoff across the side road.
<b>Vertical Alignment</b>	The line of the roadway curvature as related to the vertical direction.
<b>Vertical Clearance</b>	The clearance provided above the roadway to allow vehicles to successfully pass under a structure.
<b>Vertical Sight Distance</b>	The distance a driver can see along a vertical curve to the roadway ahead.
<b>Visual Impacts</b>	Impacts of the proposed project on potential viewers of and from the project.
<b>Volume Studies</b>	Traffic studies conducted to determine the levels of traffic during specified time periods, e.g., average daily traffic (ADT), peak hour traffic, etc.
<b>W-Beam Guardrail</b>	A roadside barrier system with railing that is W-shaped.
<b>Waste</b>	The situation where the amount of available excavation exceeds the amount of needed embankment.
<b>Waste Sites</b>	Areas established for the disposal of excess excavation or unsuitable materials.
<b>Waterway Permit Data Sheet</b>	A data form from the <b>Environmental Permits Unit</b> that includes information about waterway permits, historic bridges and other environmental issues.
<b>Weaving Sections</b>	Highway segments where the pattern of traffic entering and leaving at contiguous points of access/egress result in vehicle paths crossing each other.
<b>Wetlands</b>	Areas that are inundated or saturated by surface or groundwater at a frequency and duration sufficient to support, and that under normal circumstances do support, a prevalence of vegetation typically adapted for life in saturated soil conditions.



<b><i>SUBJECT</i></b>	<b><i>PAGE NUMBER</i></b>
<b>A</b>	
Access Control.....	1-20, 15-7
Access Control Design.....	2-14, 15-8
Access Control on Interstates and Freeways.....	5-9, 15-12
Access Control on Expressways and Four-Lane Divided Highways.....	15-12
Access Control on All Other Highways.....	15-12
Access Control on Side Streets and Roads.....	15-13
Access Control Spacing.....	15-14
Preliminary Access Control Determination.....	2-9
Public Notification.....	15-13
Access Control Letter.....	15-9, 15-10
Accessibility Requirements for Handicapped Individuals.....	Chapter Sixteen, 17-44
Acronyms, Abbreviations & Symbols.....	See the Glossary
ADA (Americans With Disabilities Act)	
Accessibility Guidelines.....	16-1
Pedestrian Access During Construction.....	16-13
Pedestrian Access Review.....	16-13
Special Provisions.....	16-15
3R Projects.....	17-44
ADA Upgrades – Cost Sharing.....	16-15
Added Sheet.....	11-35, 11-42
Addendums.....	11-28
Additional Survey.....	2-4, 2-7, 2-8, 2-13, 2-25
Aerial Lines.....	10-27
Aerial Sheets.....	2-10, 11-20, 13-8
Aerial Photo Sheet Preparation.....	2-9
Aggregates	
Gravel Embedment.....	8-4, 12-25, 14-9
Surfacing Aggregates.....	8-4
Surfacing Aggregates, Quantity Computations.....	8-12, 12-29, 12-34
Agreements.....	2-13, 2-20, 12-2, 13-22
Agreement Checks.....	2-27, 2-28
City Agreements.....	2-13, 10-31
Covenant Relinquishment Agreement.....	15-25
Final Relinquishment Agreement (FRA).....	2-27, 2-29, 2-31
Initiate Agreements.....	2-13
Irrigation Agreements.....	2-14
Railroad Agreements.....	2-14
Air Quality.....	13-17
Airway Highway Clearances.....	10-12
Alignment	
Alignment Design Values.....	3-40
Combination of Horizontal and Vertical Alignment.....	3-39
Alignment and Control Point Sheets.....	11-21
Application of Design Criteria.....	1-12
Appraisal.....	15-19
Appraisal Plans.....	15-5

<b><i>SUBJECT</i></b>	<b><i>PAGE NUMBER</i></b>
<b>A</b>	
Archeological and Historical Features .....	13-19
Archiving the Project File .....	2-35
Arterial Roadways.....	1-5, 1-7, 1-8
Asphalt (Flexible Pavement) .....	8-4, 8-6, 8-12
Asphaltic Concrete Pavement Patching.....	8-10
Flexible Pavement Surfacing Quantity Computations .....	8-12
Asphalt Surfacing Under Guardrail .....	9-17
Cold Milling .....	8-9
Mailbox Turnouts.....	10-24
Overlays.....	8-10
Pavement Item Checklist.....	12-30
Template Correction.....	8-10
At-Grade vs Interchange Recommendations.....	14-2
Auxiliary Lanes.....	6-24, 17-31
Clear Zone Requirements for Auxiliary Lanes .....	6-25
Climbing Lanes .....	3-22
Lane Configuration.....	14-2
Left-Turn Radii .....	4-26
Transition .....	4-31, 6-20
Turn Lanes.....	See Turn Lanes
Axis of Rotation.....	3-6, 6-22
<b>B</b>	
Balance Factors (Earthwork).....	7-3, 17-32
Balance Points (Earthwork).....	7-2, 11-26
Barriers (Roadside).....	5-8, 9-1, 9-4, 17-34
Barrier Offsets in Construction Zones.....	14-6
Concrete Protection Barrier .....	9-5, 9-26
Inertial Barriers.....	9-41
Justification .....	9-2
Median Barrier Treatments.....	9-25, 9-26
Benefit/Cost Analysis .....	9-4, 9-25, 17-2
Beveled Edge .....	5-3, 6-5, 17-33
Bicycle Accommodation (Interchanges) .....	5-19
Bicycle Facilities (Interstate).....	5-9
Bid Comparison and Analysis .....	12-2
Bike Lane - Highway Intersections .....	4-27
Bikeways.....	16-2, 16-4
Border Sheets.....	11-7
Borrow Pits .....	7-7, 8-6
Borrow Alternatives .....	7-7
Borrow Pit Restoration .....	7-7
Excavation-Borrow Pay Item .....	7-16, 7-17
Brick Removal.....	8-9

<b><i>SUBJECT</i></b>	<b><i>PAGE NUMBER</i></b>
<b>B</b>	
Bridge Approach Sections.....	9-5, 9-21
Bridge Pay Items (Preliminary Cost Estimate).....	12-20
Bridge Plan Sheets.....	11-28
Bridge Preventive Maintenance.....	1-15
Bridge Replaced with a Box Culvert.....	7-10
Bridge Routine Maintenance.....	1-15
Bridge Structures.....	6-33, 10-6, 17-5, 17-11, 17-26, 17-37
Bridge Channel Work.....	13-16
Bridge Grades.....	3-22, 10-8
Grade Separations.....	5-14, 10-8
High Embankments.....	10-9
Horizontal Curvature.....	10-6
Intersections.....	10-9
Pedestrian Underpass.....	16-7
Skewed Structures.....	10-7
Stream Crossings.....	10-9
Superelevation.....	3-5, 10-6
3R Projects.....	17-5, 17-11, 17-26, 17-37
Underpass Sight Distance.....	3-38
Vertical Clearances.....	10-8
Vertical Curvature.....	10-8
Broken Back Curves.....	3-3
Build Notes for Intersections and Driveways.....	4-46
Bullnose Attenuators.....	9-5, 9-21, 9-27
<b>C</b>	
Cable Guardrail.....	9-5, 9-14, 9-25, 9-27
Anchorage.....	9-14
Deflection Distance.....	9-14, 9-27
Length of Need.....	9-10
Pay Item Quantities.....	9-44
Capacity Analysis.....	4-19, 14-1
Capital Improvement.....	1-12
Categorical Exclusions (CE) (Class II Projects).....	2-18, 2-21, 13-6
Cattle Passes.....	10-21, 10-22
Changes in Pavement Determination.....	8-2, 12-10, 12-25
Change in Project Concept (Estimates).....	12-7, 12-8, 12-10
Change in Project Scope (Estimates).....	12-7, 12-8, 12-10
Changes to Design Plans.....	2-33, 15-6
Plan Revisions.....	2-33, 11-30, 15-6
Channel Changes.....	13-15
Bridge Channel Work.....	13-16
Channelization (Roadway).....	4-2, 4-47, 17-25
Islands.....	4-4, 4-50, 6-17
Medians.....	4-51, 17-26

<b><i>SUBJECT</i></b>	<b><i>PAGE NUMBER</i></b>
<b>C</b>	
CICS1 .....	2-7, 10-26, 12-6
City and/or County Officials Meeting .....	2-22
City/County Utility Cost Reimbursement.....	10-27
Class I Environmental Classification .....	2-15, 2-18, 13-6
Class II Environmental Classification .....	2-18, 2-21, 13-6
Class III Environmental Classification .....	2-15, 2-18, 13-6
Clean Air Act.....	13-17
Clean Water Act.....	13-8, 13-14, 13-17, 13-20
Clearances	
Bridge Vertical Clearances .....	10-8
Minimum Vertical Clearances for Overhead Facilities.....	3-38, 10-27
Underpasses.....	3-38, 5-14, 16-7
Vertical Clearances (Alignment Design) .....	3-38
Clear Zone .....	See Lateral Obstacle Clearance
Climbing Lanes .....	3-22
Cold Milling .....	8-9
Collector-Distributor Roads .....	1-6, 1-8
Comfort Criteria - Sag Vertical Curves .....	3-38
Communication Lines.....	10-27, 10-28
Compound Curves .....	3-3
Concrete (Rigid) Pavement.....	8-2
Concrete Shoulders.....	8-2, 8-6
Joining Existing Pavement .....	8-4
Pavement Joints.....	8-3
Pavement Patching .....	8-10
Portland Cement Concrete Pavement Design Policy.....	8-2
Quantity Computations.....	8-11
Surfacing Elevations and Grades .....	11-22
Thickness .....	5-3, 5-8, 8-2
Tining .....	8-4
Concrete Median Barriers .....	9-5, 9-26
Concrete Protection Barriers .....	9-5, 9-26
Condemnation.....	15-19
Construction Engineering (Cost Estimating).....	12-11, 12-14
Construction Items for Cost Estimates .....	12-15
Bridge Items.....	12-20
Items Affecting Construction Costs.....	12-22
Maintaining Traffic During Construction.....	12-23
Mobilization .....	12-15
New Materials .....	12-16
Other Construction Items .....	12-22
Quantities.....	12-17
Sole Sourcing.....	12-17
Special Provisions.....	12-15
Specifications .....	12-15
Standard Pay Items.....	12-16
Traffic Control Items .....	12-19



<b><i>SUBJECT</i></b>	<b><i>PAGE NUMBER</i></b>
<b>C</b>	
Construction Location .....	12-22
Construction Joints .....	8-3, 8-4
Construction Notes .....	See Standard Notes
Construction Schedule .....	12-22
Construction Under Traffic .....	12-23, 14-6, 16-13
Consultants .....	13-23
Contaminated Soils .....	13-21
Contents of Cost Estimates .....	12-11
Contingencies .....	12-14
Construction Items .....	12-15
Construction Engineering .....	12-14
Preliminary Engineering .....	12-11
Railroad .....	12-14
Right-of-Way .....	12-12
Utilities .....	12-14
Contingencies .....	12-14
Contract Preparation (Right-of-Way) .....	15-19
Contraction Joints .....	8-3
Control Access .....	See Access Control
Controlling Design Criteria .....	1-21
Corridor Protection .....	15-2
Corridor Protection Plans .....	15-2
Cost Estimate Contents .....	12-11
Cost Estimate Request Procedures .....	12-10
Changes .....	12-10
Estimate Review .....	12-10
Routing from Designer .....	12-10
Timeliness .....	12-10
Cost Estimating .....	12-1, 17-41
Change in Project Concept .....	12-10
Change in Project Scope .....	2-5, 12-10
Construction Items .....	12-15, 12-22
Contents of Cost Estimates .....	12-11
Items Often Overlooked or Omitted .....	12-23
Level of Estimate Detail .....	12-7
Request Forms .....	12-9
Request Procedures .....	12-10
Schedule of Estimates .....	12-7
Standard Pay Items .....	12-16
Uses of Cost Estimates .....	12-1

<b><i>SUBJECT</i></b>	<b><i>PAGE NUMBER</i></b>
<b>C</b>	
Cost Sharing .....	12-3, 17-38, 17-41
CICS1 Lookup.....	12-6
Federal Funding Programs.....	12-3
Funding Splits Defined by Stations.....	12-6
Lump Sum Funding Splits .....	12-6
Nonparticipating Items (Federal Funding).....	12-5
Participating (Federal Funding) .....	12-4
Participation by Others .....	12-5
Railroad .....	12-5
Routing from Designer .....	12-10
Salvaging Items.....	12-4
Statewide Transportation Improvement Program (STIP) .....	12-4
Utilities .....	12-5
Cost Updates .....	2-10, 2-16, 2-26, 12-8
Covenant Relinquishment Agreement.....	2-16, 2-29, 15-25
Crash Cushions and Impact Attenuators .....	9-41
Crest Vertical Curves .....	3-24, 3-32
Cross-Section Sheets	
Drainage Structure Cross-Section Sheets .....	11-27
Roadway Cross-Sections Sheets .....	11-29
Typical Cross-Section Sheets .....	11-6, 11-18
Cross-Sections (Typical) .....	See Typical Cross-Sections
Crossovers.....	5-8, 14-7
Crosswalks .....	4-27, 5-19, 14-3, 16-3, 16-7
Crowned Cross Slopes .....	6-2
Crushed Rock Quantity Calculations .....	8-12
Culverts (Rural Driveway) .....	4-39
Hydraulic Design .....	4-39
Culverts (3R).....	17-45, 17-46
Curbs .....	6-16
Curb Cuts (Driveway).....	4-41
Curb Design Considerations.....	6-19
Curbs and Flumes (Erosive Soils) .....	6-19, 17-21
Curb Heights .....	6-17, 17-26
Curb Types .....	6-17
Curb Warrants.....	6-16
Guardrail and Curbs .....	9-39
Roundabouts.....	4-5, 6-17
Curb Ramps.....	4-27, 16-3, 16-8
Curves .....	See Horizontal Curves or Vertical Curves
Cut Slopes .....	6-27

<b><i>SUBJECT</i></b>	<b><i>PAGE NUMBER</i></b>
<b>D</b>	
Daylighting .....	6-32, 7-7
Definitions & Terms .....	See the Glossary
Deleted Sheet .....	11-36, 11-42
Delineators .....	14-4
Departure From Standards .....	1-32
Design Exceptions .....	1-32
Design Relaxations of the MDS .....	1-33
Desirable Design Conditions .....	1-34
Design Alternatives (Cost Estimating) .....	12-2
Design Controls .....	1-18
Access Control .....	See Access Control
Design Speed .....	1-18, 5-2, 14-7, 17-5
Design Vehicle .....	4-4, 4-25, 5-2, 14-7
Design Year Forecast Traffic .....	1-18, 5-2, 17-5
Fixed Obstacle Clearance (3R) .....	1-19, 6-25, 17-29
Horizontal Clear Zone (Clear Zone) .....	1-19, 6-25, 9-2, 17-29
Rural/ Municipal .....	1-19
Sight Distance .....	See Sight Distance
Terrain .....	1-18
Design Exceptions .....	1-32
Design Plan-In-Hand (Activity 5315) .....	2-10, 17-20, 17-21, 17-25, 17-26, 17-34, 17-37, 17-38, 17-39, 17-45
Conduct the Plan-In-Hand Inspection .....	2-11
Plan-In-Hand (Design Detail) Plans .....	2-10, 11-3
Plan-In-Hand Plan Distribution .....	2-11
Plan-In-Hand Report (Activity 5318/5338) .....	2-5, 2-12, 17-20, 17-26, 17-34, 17-40
Design Plans .....	11-1
Design Plans to Utility Unit .....	11-3
Functional Design Plans .....	11-2
Design Detail Plans .....	11-3
Preliminary Design Plans .....	11-2
Pre-PS&E Plans .....	11-4
PS&E Plans .....	11-4
Right-of-Way .....	See Right-of-Way Design Plans
Design Plans to Utilities Section (Activity 5350) .....	2-28
Design Preparation for Public Hearings (Activity 5323/5324) .....	2-17
Design Process Outline (DPO) .....	2-1
Design Relaxations of the MDS .....	1-33
Design Review Support Processes (Activity 5340) .....	2-27
Design Speed .....	1-18, 5-2, 14-7, 17-5
Interstate .....	5-2
Temporary Roadway .....	14-7
3R Projects .....	17-5
Design Standards .....	1-3
Departure From .....	1-32
3R Projects .....	17-3

<b><i>SUBJECT</i></b>	<b><i>PAGE NUMBER</i></b>
<b>D</b>	
Design Vehicle (Intersection Turning Template).....	4-25
Interstate .....	5-2
Roundabouts.....	4-4
Temporary Roadway .....	14-7
Design Year Forecast Traffic.....	1-18
Interstate .....	5-2
3R Projects .....	17-5
Desirable Design Guidance.....	1-26
Departure From.....	1-34
Detail Sheet .....	11-36
Detours .....	12-23, 14-13
Dikes.....	6-27, 17-30
Distribution Analysis (Earthwork) .....	7-3
Ditch Widening.....	7-7
Diverging Diamond Interchange.....	5-15
Dowel Bars .....	8-2, 8-3, 8-4
Downloadable Plan Border Sheets.....	11-7
Drainage .....	2-8, 6-30
At Superelevation Transition .....	3-6, 3-22
Interstate .....	5-9
Minimum Grades.....	3-22, 3-26
Pavement Subdrains.....	8-5
Temporary Roads .....	14-8
3R Projects .....	17-45
Drainage Structure Cross-Section Sheets.....	11-27
Drainage and Hydraulic Information.....	11-10
Driveways .....	4-35
Build Notes for Driveways .....	4-46
Driveway Earthwork .....	7-17
Driveway Surfacing .....	4-43
Rural Driveways.....	4-36
Rural Driveway Culvert Pipes.....	4-39
3R Projects .....	17-25
Urban Driveways.....	4-41
Dry Run (Public Hearing) .....	2-17

<b><i>SUBJECT</i></b>	<b><i>PAGE NUMBER</i></b>
<b>E</b>	
Easements	
Permanent Easements .....	15-4
Railroad Easements .....	15-5
Temporary Easements .....	15-4
Earthwork .....	7-1, 17-32
Balances .....	6-32, 7-1
Balance Factors .....	7-3
Borrow Alternatives .....	7-7
Borrow Pits .....	7-7, 7-16, 7-17
Bridge Replaced with a Box Culvert .....	7-10
Check Earthwork Information .....	2-32
Computations .....	7-2
Contaminated Soils .....	13-21
Data Requirements (Computations) .....	7-2
Distribution Analysis .....	7-3
Driveways .....	7-17
Earthwork Around Guardrail .....	9-17
Earthwork Measured in Embankment .....	7-16
Established Quantities .....	7-16
Example Calculations .....	7-18
Excavation (Established Quantity) .....	7-16
Excavation and Excavation Borrow .....	7-16
Finalizing Roadway Earthwork .....	7-21
Haul Considerations .....	7-5
Moisture Content .....	7-5
Need for Additional Cross-Sections .....	7-11
Roadway Grading .....	7-17
Settlement Surcharge .....	7-32
Shear Lines .....	7-13
Staged Construction/Phasing .....	7-9
Subsidiary Earthwork .....	7-17
Temporary Roads .....	7-5, 14-9
3R Project Earthwork .....	17-32
Unsuitable Materials .....	7-10
Waste Alternatives .....	7-8
Waste Sites .....	7-7
Earthwork Data Sheets .....	11-26
Electrical Power Lines .....	10-27, 10-28
Embankment .....	7-16, 7-17
Embankment Foundation Report .....	7-31
End Anchorage Assembly .....	9-21
End Treatments (Guardrail Terminal Section) .....	9-21
Endangered Species (Wildlife Issues) .....	13-18
Engineering and Contingencies .....	12-14
Engineering Review .....	2-2, 13-2
Locations Studies .....	13-3

<b><i>SUBJECT</i></b>	<b><i>PAGE NUMBER</i></b>
<b>E</b>	
Environmental Classification .....	13-6
Class I Projects .....	13-6, 13-19
Class II Projects .....	13-6
Class III Projects .....	13-6, 13-19
Environmental Assessment (EA).....	13-6
Environmental Impact Statement (EIS) .....	13-6
Environmental Permits	
Section 10 of the Rivers and Harbors Act of 1899 .....	13-15
3R Projects .....	17-42
Wetlands and Section 404 Permits.....	13-8, 13-14
Environmental Studies	
Air Quality .....	13-17
Archeological and Historic Features .....	13-19
Environmental Classification .....	13-6
Flood Plains .....	13-16
4 (f) Evaluation .....	13-7
Noise.....	13-17
6 (f) Lands.....	13-7
Social, Economic and Environmental Impacts .....	13-19
Water Quality .....	13-17
Wetlands .....	13-8
Wildlife Issues .....	13-18
Erosion Control .....	6-31, 13-14, 17-48
Temporary Roads .....	14-9
Erosive Soils .....	6-19
Established Quantities .....	7-16
Estimate Review .....	12-10
Estimating (Cost) .....	12-1
Estimating	
Cost Update 1 (Status Code 30) .....	2-10, 12-8
Cost Update 2 (Status Code 40) .....	2-16, 12-8
Cost Update 3 (Status Code 45) .....	2-26, 12-8
Excavation .....	7-16, 7-17
Expansion Joints.....	8-3
Expressway System.....	1-11
3R Standard for Access only at Interchanges.....	1-3
Access Control.....	5-9, 15-12
New Four-Lane Divided Highway Using Existing Two-Lane Highway.....	6-24

<b><i>SUBJECT</i></b>	<b><i>PAGE NUMBER</i></b>
<b>F</b>	
Federal Agencies .....	13-22
Federal Aviation Administration (FAA) .....	10-2
Federal Funding Programs.....	12-3
Highway Safety Improvement Program (HSIP).....	12-3
National Highway Performance Program (NHPP) .....	12-3
Rail Highway Crossings (RRZ).....	12-3
Surface Transportation Block Grant Program (STBG).....	12-3
Fencing .....	10-21
Behind Retaining Walls .....	10-22
Cost Estimates .....	12-13
Interstate .....	5-8, 10-21
Sidewalks Adjacent to Steep Slopes .....	16-6
Snow Control.....	10-20
Festoon Outlets.....	10-32
FHWA Design Discipline Support Tool for Interchanges .....	5-12
Field Entrances	
Access Control.....	15-7
Earthwork.....	7-17
Grading .....	4-36
Surfacing.....	4-43
Type D Median Break.....	4-54
Width.....	4-36
Fill Slopes	
Fill Slopes (Parallel) .....	6-26
Fill Slopes (Transverse) .....	6-27
3R Projects .....	17-30
Final Plan Review for P.S.& E.....	2-31, 2-33
Final Relinquishment Agreement (FRA).....	2-29
Finalizing Roadway Earthwork .....	7-21
Finding of No Significant Impact (FONSI).....	13-6
Fixed Obstacle Clearance .....	6-25, 17-29
Flare Rates (Guardrail) .....	9-13
Flexible Pavement .....	See Asphalt
Floodplains .....	13-16, 17-42, 17-47
Floodplain/Floodway Permit.....	13-16, 17-42
Flumes (Erosive Soils).....	6-19
Foundation, Base and Surface Courses.....	8-13
4(f) Evaluation.....	13-7
Freeway.....	5-15, 15-12
3R Standards .....	1-3
Free-Flow Right Turn Lanes.....	4-34
Frontage Roads .....	4-17
Functional Classification	
National Highway Functional Classification Map (Nebraska).....	1-3
State Highway Functional Classification Map (Nebraska).....	1-4
Functional Design Plans .....	11-2

<b><i>SUBJECT</i></b>	<b><i>PAGE NUMBER</i></b>
<b>F</b>	
Funding.....	12-3
Federal Funding Programs.....	12-3
Lump Sum Funding Splits.....	12-6
Nonparticipating Items (Federal Funding).....	12-5
Participating (Federal Funding).....	12-4
Participation by Others.....	12-5
Railroad.....	12-5
State of Nebraska Funding.....	12-5
Utilities.....	12-5
Funding Splits Defined by Stations.....	12-6
<b>G</b>	
General Information Sheets.....	11-21
Geotechnical Features.....	6-32
Grade Control Structures (Channel Changes).....	13-15
Grades.....	3-22
Bridge Grades.....	10-8
Critical Length of Grade.....	3-22
Maximum Grades.....	3-22
Minimum Grades for Drainage.....	3-6, 3-22
Rural Driveways.....	4-36
Sidewalk.....	16-5
Temporary Roads Grades.....	14-8
Urban Driveways.....	4-41
Grade Separations.....	5-11, 17-26
Grade Separation Structures.....	5-14
Underpass Roadways.....	5-14, 6-33
Overpass Roadways.....	5-14
Grading (Roadway).....	7-17
Gravel and Crushed Rock Quantity Calculations.....	8-12, 12-31
Gravel Embedment.....	8-4, 12-25, 14-9
Guardrail.....	9-1
Bridge Approach Sections/Special Bridge Approach Sections.....	9-5, 9-21
Bullnose Attenuators.....	9-5, 9-21, 9-27
Cable Guardrail.....	See Cable Guardrail
Concrete Protection Barrier.....	9-5, 9-26
Cost Effectiveness Analysis (RSAP).....	9-4, 17-34
Culvert Mounted Guardrail Posts.....	9-37
Curve Correction Factor for Lateral Obstacle Clearance.....	9-7
Deflection Distance.....	9-14
Earthwork Around Guardrail.....	9-17
Fixed Obstacle Clearance.....	6-25, 17-29
Flare Rate.....	9-13
Grading for Guardrail.....	7-11, 9-17
Guardrail Components.....	9-13
Guardrail and Curbs.....	9-39



***SUBJECT*** ***PAGE NUMBER***

**G**

Guardrail (Continued)

- Guardrail Design Procedures .....9-6
- Guardrail Design at Culverts ..... 9-37
- Guardrail at Intersections ..... 9-37
- Guardrail Over Low-Fill Culverts..... 9-37
- Guardrail Spans with Posts Eliminated..... 9-37
- Interstate Guardrail ..... 5-8
- Justification ..... 9-2
- Lateral Extent of Obstacle ..... 9-7
- Lateral Obstacle Clearance (Clear Zone) ..... 6-25, 9-2
- Midwest Guardrail System (MGS) ..... 9-5, 9-13, 9-38
- MGS Installed Near Slopes ..... 9-38
- Median Barrier Treatments ..... 9-5, 9-25, 9-26
- Options..... 9-2
- Pay Item Quantities ..... 9-44
- Remove Guardrail ..... 9-44
- Runout Length..... 9-7
- Runout Path ..... 9-10
- Semi-Rigid Guardrail ..... 9-5, 9-27
- Surfacing Under Guardrail..... 9-17
- 3R Projects ..... 17-34
- Thrie-Beam Guardrail..... 9-5, 9-13
- Types of Barriers Used in Nebraska..... 9-5
- W-Beam Guardrail ..... 9-5, 9-13
- W-Thrie Beam Transition Section..... 9-5
- Guardrail End Treatments ..... 9-21
- End Anchorage Assembly ..... 9-21
- Guardrail End Treatment, Type I ..... 5-8, 9-21
- Guardrail End Treatment, Type II ..... 9-21
- Low-Speed Roadways ..... 9-21

**H**

- Habitat (Wildlife Issues) ..... 13-18
- Handrails for Pedestrian Ramps and Stairs..... 16-12
- Haul Considerations..... 7-5
- Hazardous Materials ..... 13-20
- Guidelines for Handling Contaminated Soils on Highway R.O.W..... 13-21
- Guidelines for Handling Petroleum Tanks/Leaks ..... 13-20
- Materials Prohibited or Restricted as Fill Materials ..... 13-20
- Headlight Distance..... 3-34, 3-38
- Highway Commission Statement..... 2-19, 15-13
- Highway Improvement Programming Request (NDOT Form 73)..... 12-6
- Highway Inventory System (CICS1)..... 2-7, 10-5, 12-6
- Highway Safety Improvement Program (HSIP) ..... 12-3
- Highway Classification ..... 1-3
- Historic Sites ..... 13-7, 13-19

<b><i>SUBJECT</i></b>	<b><i>PAGE NUMBER</i></b>
<b>H</b>	
Horizontal Alignment	
Combination of Horizontal and Vertical Alignment .....	3-39
Design Values .....	3-40
Horizontal Alignment Data .....	3-40, 11-8
Horizontal Alignment Design .....	3-2
Horizontal Alignment, Intersections and Driveways .....	4-20
Maximum Deflection Without a Curve .....	3-2
Preliminary Horizontal Alignment Design .....	2-6
3R Horizontal Alignment Design .....	17-22
Horizontal Clear Zone .....	1-19, 6-25, 9-2, 9-7, 17-29
Horizontal Curvature .....	3-2
Bridge Structures .....	10-6
Broken Back Curves .....	3-3
Compound Curves .....	3-3
Pavement Widening on Curves (Off-Tracking) .....	3-6, 17-23
Reverse Curves .....	3-3
Simple Curves .....	3-2
Spiral Transitions .....	3-3, 5-24, 11-8, 17-23
Superelevation .....	3-5, 17-23
HSIP (Highway Safety Improvement Program) .....	12-3
Hydrated Lime for Asphalt Mixtures .....	8-6, 12-26
Hydraulic Considerations (3R Projects) .....	17-45
Hydraulic Design of Driveway Culverts .....	4-39
<b>I</b>	
Impact Attenuators .....	9-41
Improvement Values (Right-of-Way) .....	12-13
Individual Construction Notes .....	11-7
Inertial Barriers .....	9-41
Information Meeting Prior to Appraisal and Acquisition .....	2-21, 2-28, 15-19
Initial Project Review and Setup (Activity 5308) .....	2-2
Intelligent Transportation System .....	14-5
Interchanges .....	5-11, 17-26
Adaptability .....	5-13
Fencing .....	5-8, 10-21
FHWA Design Discipline Support Tool .....	5-12
Lighting .....	5-19, 10-33
Pedestrian and Bicycle Accommodation .....	5-19
Spacing .....	5-19
Interchange Configurations .....	5-15
Diverging Diamond Interchange .....	5-15
Single Point Urban Interchange .....	5-15
Interchange Design Considerations .....	5-12
Interchange Justification Report .....	5-11
Interchange Lighting .....	5-19, 10-33
Interchange Modification Report .....	5-11
Interchange Ramps .....	5-19, 5-26
Interchange Warrants .....	5-13

<b><i>SUBJECT</i></b>	<b><i>PAGE NUMBER</i></b>
<b>I</b>	
Intersections .....	4-1
Intersection Build Notes .....	4-46
Intersection Design Considerations	
Bike Lane/Highway Intersections.....	4-27
Bridges.....	10-9
Capacity and Level of Service .....	4-19
Design Vehicle .....	4-25
Guardrail at Intersections .....	9-37
Horizontal Alignment .....	4-20
Intersection Skew.....	4-20
Intersections on Curved Alignments .....	4-24
On-Street Parking .....	4-26
Pedestrian Crossings .....	4-27, 16-7
Profile.....	4-24
Radius Returns .....	4-25, 4-26
Railroad-Highway Crossings .....	4-27, 10-2
Sight Distance .....	3-32, 3-34, 4-16
Signs.....	4-27
3R Projects .....	17-25
Traffic Control .....	4-34, 14-2
Transit Services .....	4-26
Turn Lanes.....	4-27
Intersection Locations	
Frontage Roads .....	4-17
Intersection of Two State Highways .....	4-14
Rural Intersections .....	4-16
Urban Intersections .....	4-16
Intersection Surfacing .....	4-43
Intersection Types.....	4-2
Channelized Intersections .....	4-2
Reduced Conflict Intersections.....	4-6
Roundabouts.....	4-3
Unchannelized Intersections .....	4-2
Interstate System .....	1-9, 5-2
Access Control.....	5-9, 15-12
Alignment.....	5-2
Bicycle Facilities.....	5-9, 16-4
Design Speed.....	5-2
Design Year .....	5-2
Design Values .....	5-2
Design Vehicle .....	5-2
Drainage Design .....	5-9
Fencing .....	5-8, 10-21, 12-13
Guardrail .....	5-8
Median Crossovers (Left-in-Place) .....	5-8
Median Width .....	4-52, 5-3

<b><i>SUBJECT</i></b>	<b><i>PAGE NUMBER</i></b>
<b>I</b>	
Interstate System (Continued)	
Pedestrian Facilities .....	5-9
Plans .....	5-9
Rest Areas .....	5-9
Right-of-Way .....	5-9
Surfacing .....	5-3, 8-2
3R Projects .....	17-6
Typical Cross-Section .....	5-3
Utilities .....	5-8
Water Quality .....	5-8, 13-17
Weigh Stations .....	5-9
Irrigation Agreements .....	2-14
Islands .....	4-4, 4-50
Items Affecting Construction Costs .....	12-22
Construction Location .....	12-22
Construction Schedule .....	12-22
Construction Under Traffic .....	12-23
Detours .....	12-23
Items Often Overlooked or Omitted .....	12-23
Site Specific Features .....	12-22
Urban/Rural Location .....	12-22
ITS .....	11-26, 14-5
<b>J</b>	
Jacking Pipes .....	12-26
Joining Existing Pavement .....	8-4
Joint Access (Driveways) .....	4-36, 15-8
Joint Diagram .....	8-3
Joints (Pavement) .....	8-3
<b>K</b>	
K Values (Vertical Curves) .....	3-26
<b>L</b>	
Landscaping .....	10-18
Plans .....	11-26
Roundabout Landscaping .....	10-19
Tree Planting and Removal .....	10-19
Land Values .....	12-12
Lane Configuration .....	14-2
Large Scale Plan Sheets .....	11-11, 11-22
Large Tree Removal .....	12-26, 12-27
Lateral Clearance to Work Zones (Temporary Roads) .....	14-8
Lateral Obstacle Clearance (Horizontal Clear Zone) .....	1-19, 6-25, 9-2, 9-7, 17-29
Clear Zone Requirements for Auxiliary Lanes .....	6-25
Lateral Offset to Obstruction .....	1-23
Shoulder Width .....	1-23
Lateral Extent of Obstacle .....	9-7

<b><i>SUBJECT</i></b>	<b><i>PAGE NUMBER</i></b>
<b>L</b>	
Left-in-Place Median Crossovers .....	5-8
Level of Estimate Detail .....	12-7
Level Terrain .....	1-18
Liaison with other Agencies/Organizations .....	10-25, 13-22
Lighting .....	5-19, 10-31, 11-26
3R Projects .....	17-11, 17-38
Limits of Construction (Design Detail) Plans .....	11-3
Load Transfer Devices .....	8-3
Local and Regional Agencies .....	13-22
Local Roads .....	1-6, 1-8
Location Studies .....	13-3
Lump Sum Funding Splits .....	12-6
<b>M</b>	
Mailbox Turnouts and Supports .....	10-23, 17-30
Maintaining Traffic During Construction .....	12-23, 14-6
Construction Under Traffic .....	14-6
Crossovers .....	5-8, 14-7
Detours .....	12-23, 14-13
Temporary Surfacing .....	14-7
Temporary Roads .....	12-23, 14-7
Maintenance Projects .....	1-14
Bridge Preventive Maintenance Activities .....	1-15
Maximum Grade Raise .....	1-15, 17-3
Preventive Maintenance .....	1-15
Routine Bridge Maintenance Activities .....	1-14
Routine Maintenance .....	1-14
Major Collector Roadways .....	1-6, 1-8
Markings (Traffic) .....	14-4
Maximum Grades .....	3-22
Rural Driveways .....	4-36
Maximum Horizontal Deflection Without a Curve .....	3-2
Maximum Superelevation Rate .....	3-5
Bridge Structures .....	3-5, 10-6
Temporary Roads .....	14-8
3R Projects .....	17-23
Meetings .....	See Public Meetings
Median Barriers .....	9-5, 9-25, 9-26
Median Breaks .....	4-53
Drainage .....	4-53
Type A .....	4-53
Type B .....	4-53
Type C .....	4-54
Type D .....	4-54
Median Types .....	4-51

***SUBJECT*** ***PAGE NUMBER***

**M**

Medians .....	4-51
Median Barrier Treatments .....	9-25, 9-26
Median Breaks .....	4-53
Median Break Drainage .....	4-53
Median Crossovers (Left-in-Place) .....	5-8, 14-7
Median Uses .....	4-51
Median Width .....	4-52, 5-3
Median Maintenance Turnarounds (Rural) .....	10-24
3R Projects .....	17-26
Two-Way Left-Turn Lanes .....	4-28, 4-51
Midwest Guardrail System (MGS) .....	9-5, 9-13, 9-38
Migratory Bird Act .....	13-18
Minimum Design Standards .....	See Nebraska Minimum Design Standards
Minimum Grades .....	3-23
Minimum Horizontal Curve Radius .....	3-2, 3-5
Minor Arterial Roadways .....	1-5, 1-8
Moisture Content (Earthwork) .....	7-5
MSE Walls .....	10-22, 12-26
Municipal Cost Sharing .....	12-5, 12-6, 17-38, 17-44

**N**

National Environmental Policy Act (NEPA) .....	12-2, 13-6, 13-19
National Highway Freight Network .....	1-10
National Highway Functional Classification Map (Nebraska) .....	1-4
National Highway Performance Program (NHPP) .....	12-3
National Highway System (NHS) .....	1-9, 17-6
Need for Additional Cross-Sections .....	7-11
NDOT Form 65 (Request for Agreement) .....	2-13
NDOT Form 73 (Highway Improvement Programming Request) .....	12-6
NDOT Form 76 (Principal Controlling Design Criteria) .....	1-28
Instructions .....	1-28
NDOT Form 280 (PS&E Required Sheet) .....	2-32
NDOT Form 342 (Project Information Sheet) .....	12-9
NDOT Form 343 (Project Quantity Sheet) .....	12-9
NEPA (National Environmental Policy Act) .....	12-2, 13-6, 13-19
Negotiation Plans .....	15-2,
New and Reconstructed Bridges .....	10-6
New and Reconstructed Design Criteria .....	1-12
New Construction Materials .....	12-16
Non-Controlling Design Criteria .....	1-22
“No Rise” Certificate .....	13-16
Noise .....	13-17
Notes .....	See Standard Notes

<b><i>SUBJECT</i></b>	<b><i>PAGE NUMBER</i></b>
<b>O</b>	
Object Markers.....	14-4
Offset Right-Turn Lanes.....	4-32, 17-31
Off-Tracking (Pavement Widening on Curves).....	3-7, 17-23
Old Road Obliteration.....	10-22
On-Street Parking.....	4-26, 10-34
Overhead Signs.....	3-38, 14-3
Overhead Clearance.....	3-38, 10-8
Overlays.....	8-10, 17-3
Taper Rate.....	8-10, 17-22, 17-33
Overpass Roadways.....	5-14
Roadway Cross-Section.....	5-14
Ownership Plans.....	15-3
<b>P</b>	
Parking.....	4-26, 10-34
Passing Sight Distance.....	3-33
Pavement Design Determination.....	8-1
Pavement Design Input.....	8-1
Pavement Determination Development.....	8-1
Pavement Edge Dropoffs.....	8-10
Pavement Edge Profile.....	3-7
Pavement Item Checklist.....	12-30
Pavement Item Quantities	
Flexible Pavement Items (Asphalt).....	12-30
Gravel and Crushed Rock Quantity Computations.....	8-12, 12-31
Hydrated Lime for Asphalt Mixtures.....	12-26
Pavement Item Checklist.....	12-30
Rounding of Pavement Quantities.....	12-29
Pavement Joints.....	8-3
Construction Joints.....	8-3
Contraction Joints.....	8-3
Expansion Joints.....	8-3
Joining Existing Pavement.....	8-4
Policy for Longitudinal Joints.....	8-4
Pavement Markings.....	14-4
Pavement Patching.....	8-10
Pavement Rehabilitation.....	8-9
Pavement Subdrains.....	8-5
Pavement Types and Thicknesses.....	8-2
Pavement Widening on Curves (Off-Tracking).....	3-7, 17-23
Pedestrian Access During Construction.....	16-13
Pedestrian Accommodation (Interchanges).....	5-19
Pedestrian Crossings.....	14-3, 16-7
Pedestrian Crosswalks.....	4-27, 5-19, 16-7
Pedestrian Facilities (Interstate).....	5-9
Pedestrian Ramps.....	16-11
Pedestrian Signals.....	14-5
Percentage of Work Near Railroads.....	10-1, 12-2
Permanent Easements.....	4-36, 15-4, 15-8

<b><i>SUBJECT</i></b>	<b><i>PAGE NUMBER</i></b>
<b>P</b>	
Permits (Utilities on DOR Right-of-Way).....	2-7, 10-26
Petroleum Tanks /Leaks .....	13-20
Phasing.....	5-12, 7-4, 7-9, 12-23, 14-6
Phasing Plan Sheets.....	11-21
Piggyback Plan Sheets (Plan over Plan).....	11-7, 11-10, 11-25
Pipelines .....	10-29
Plan and Profile Sheets.....	11-7, 11-8, 11-11, 11-25
Plan Border Sheets (Downloadable) .....	11-7
Plan-in-Hand .....	2-10
3R Projects .....	17-20, 17-21, 17-25, 17-26, 17-34, 17-37, 17-38, 17-39, 17-45
Plan-in-Hand Plans (Preliminary Design Plans) .....	2-10, 2-11, 11-1, 11-2
Plan-in-Hand Report .....	2-12, 17-20, 17-26, 17-34, 17-40
Plan Revisions .....	2-33, 2-34, 11-30, 12-6, 15-6
Plan Set Organization .....	11-11
A Sheet (Title Sheet).....	11-18
B Sheets (The Typical Cross-Section).....	11-6, 11-7, 11-18
C Sheets (Summary of Quantities).....	11-20
D Sheets (Soil and Materials Survey).....	11-20
E Sheets (Environmental or Aerial Sheets) .....	2-9, 11-2, 11-7, 11-20
F Sheets (Alignment and Control Point) .....	11-7, 11-21
G Sheets (General Information) .....	11-2, 11-6, 11-7, 11-21
H Sheets (Phasing Plan).....	11-21
J Sheets (Large Scale Plans).....	5-9, 11-7, 11-11, 11-22
K Sheets (Utilities Plan Sheets).....	11-25
L Sheets (Plan, Plan over Plan, and Plan and Profile).....	11-7, 11-11, 11-25
M Sheets (Traffic Plans).....	11-26
N Sheets (Roadway Lighting Plans).....	11-26
O Sheets (Intelligent Transportation System Plans) .....	11-26
P Sheets (Landscaping and Erosion & Sediment Control Plans).....	11-26
Q Sheets (Earthwork Data) .....	11-26
R Sheets (Drainage Structure Cross-Sections) .....	11-27
S Sheets (Bridge Plans).....	11-28
T Sheets (Bridge Special Plans).....	11-28
U Sheets (Roadway Special Plans).....	11-28
V Sheets (Other Plans as Needed) .....	11-28
W Sheets (Right-of-Way Plans).....	11-28, 15-1
X Sheets (Roadway Cross-Sections) .....	11-29
Plan Sheet Scales.....	11-11
Rural .....	11-11
Urban .....	11-11
Planning, Allocation, and Funding (Cost Estimating).....	12-1
Planning and Scheduling .....	13-2
Plans.....	See Design Plans
Posted Speed (Design Speed as a Function of).....	1-18, 5-2, 5-12, 14-7
Power Lines .....	3-38, 10-27, 10-28, 12-14
Practical Design .....	1-2, 17-17
Preliminary Alignment Design for Bridge Hydraulics (Activity 5306/5312) .....	2-4
Preliminary Design Plans .....	11-2



<b><i>SUBJECT</i></b>	<b><i>PAGE NUMBER</i></b>
<b>P</b>	
Preliminary Engineering (Cost Estimates) .....	12-11
Preliminary Roadway Design (Activity 5307/5309) .....	2-4
Preliminary Right-of-Way Design .....	15-3
Preliminary Right-of-Way Plan Review (Activity 5345) .....	2-27, 15-5
Pre-PS&E Plans.....	11-4
Preparation of Final Plans Package/Final Plan Review for P.S. & E. (Activity 5369/5368) .....	2-31
Preventive Maintenance.....	1-15
Principal Arterial Roadways .....	1-5, 1-7
Priority Commercial System .....	1-11
Shoulder Width.....	6-2, 17-28
Professional Engineer Seal and Signature .....	11-30
Profile Grade Line (Vertical Alignment) .....	3-21
Project Coordination Meetings .....	13-5
Project Information Sheet (NDOT Form 342) .....	12-9
Project Rejected or Withdrawn From a Letting .....	11-42
Project Scope .....	2-5, 12-10
Project Scoping Changes.....	2-5, 12-10
Project Scope Review .....	2-5
Project Quantity Sheet (NDOT Form 343).....	2-9
Property Owners Pre-Hearing .....	2-19, 2-22
PS&E Plans .....	11-4
PS&E Required Sheet (NDOT Form 280) .....	2-32
Public Hearings.....	2-17
Dry Run.....	2-17
Public Information Meetings .....	2-19, 2-21, 13-12, 13-22, 15-19
Public Interest Letters .....	15-20
Public Meetings.....	2-19, 16-14
City and/or County Officials Meeting .....	2-22
Information Meeting Prior to Appraisal and Acquisition.....	2-21, 15-19
Plan Requirements .....	2-20
Property Owners Pre-Hearing .....	2-22
Public Information Meetings .....	2-21, 15-19
Public Notification of Wetlands Procedures .....	13-13
Public Participation and Input.....	13-22

<b><i>SUBJECT</i></b>	<b><i>PAGE NUMBER</i></b>
<b>Q</b>	
Quantity and/or Pay Item Changes .....	11-36
Quantities (Cost Estimating).....	12-17
Quantity Calculation Guidance .....	12-19
<b>R</b>	
Radius Returns .....	4-25, 4-26
Rail Highway Crossings (RRZ).....	12-3
Railroads.....	10-1
Cost Estimates .....	12-5, 12-14, 12-26
Funding .....	12-3, 12-5
Percentage of Work Near Railroads .....	10-1, 12-2
Railroad Agreements.....	2-14
Railroad Easements, Rights or Leases.....	15-5
Railroad-Highway Crossings .....	4-27, 10-2, 14-13
Railroad-Highway Crossing Surfacing .....	10-3
3R Projects .....	17-37
Raised Medians .....	4-51, 17-26
Ramps (Pedestrian) .....	16-11
Ramps (Interchange) .....	5-19
Baseline .....	5-26
Design Vehicle .....	4-25, 5-2
Earthwork.....	5-26
General Design Considerations.....	5-20
Identification .....	5-26
Spiral Transition Curves .....	5-24
Stationing .....	5-26
Types .....	5-20
RBP (Risk Based Project) .....	1-32, 11-32, 12-4, 15-20, 15-21
Reduced Conflict Intersections.....	4-6
Re-establish Land Monuments and Property Corners .....	15-24
Rehabilitation (Pavement).....	8-9
Related Construction Items .....	12-27
Relaxations of the MDS .....	1-33
Relinquishment and Abandonment .....	2-16, 2-29, 15-25
Relocation Assistance (Right-of-Way).....	12-13, 15-19
Removal Items .....	2-27, 15-20
Removal Notes .....	2-27, 11-8
Removal of Existing Surfacing .....	7-4, 7-8, 8-9
Cold Milling .....	8-9
Brick Removal.....	8-9
Rural Projects.....	7-8
Urban Projects .....	7-9
Remove Guardrail.....	9-44
Remove Sign, Post, and Footing.....	12-27

<b><i>SUBJECT</i></b>	<b><i>PAGE NUMBER</i></b>
<b>R</b>	
Request for Agreement (NDOT Form 65).....	2-13
Request Forms (Cost Estimating) .....	12-9
Highway Improvement Programming Request (NDOT Form 73) 2-2, 2-4, 2-5, 8-1, 12-6, 13-2	
Initial Project Data (NDOT Form 333).....	2-4, 2-16, 2-26
Project Data Revision (NDOT Form 334) .....	2-16, 2-26
Project Information Sheet (NDOT Form 342).....	2-10, 2-16, 2-26, 12-9
Project Quantity Sheet (NDOT Form 343).....	2-10, 2-16, 2-26, 12-9
Request Procedures (Cost Estimating) .....	12-10
Rest Areas .....	5-9
Resurfacing, Restoration and Rehabilitation (3R) Projects .....	17-1
ADA .....	17-44
Balance Factors (Earthwork) .....	17-32
Benefit/Cost Analysis .....	17-2
Bridges.....	1-14, 17-5, 17-11, 17-26, 17-37
Cost Estimating .....	17-41
Cost Sharing .....	17-38, 17-44
Cross-Sections.....	17-27
Culverts.....	17-45, 17-46
Curbs and Flumes .....	17-21
Curb Heights .....	17-26
Design Criteria .....	1-13, 17-3
Design Speed.....	17-5
Design Year .....	17-5
Dikes .....	17-30
Drainage .....	17-45
Driveways .....	17-25
Earthwork.....	17-32
Environmental Permits .....	17-42
Erosion Control .....	17-48
Fill Slopes .....	17-30
Fixed Obstacle Clearance .....	17-29
Floodplains.....	17-42, 17-47
Floodway Permit .....	17-42
Grade Separations .....	17-26
Guardrail Design Criteria .....	17-34
Horizontal Alignment Design .....	17-22
Horizontal Clear Zone .....	17-29
Hydraulic Considerations .....	17-45
Interchanges .....	17-26
Intersections.....	17-25
Intersection Sight Distance.....	17-25
Interstate.....	17-6
Lighting .....	17-11, 17-38
Mailbox Turnouts and Supports.....	17-30

<b><i>SUBJECT</i></b>	<b><i>PAGE NUMBER</i></b>
<b>R</b>	
Resurfacing, Restoration and Rehabilitation (3R) Projects (Continued)	
Mainline Surfacing Taper Rate .....	17-33
Medians .....	17-26
National Highway System (NHS).....	17-6
Pavement Widening on Curves (Off-Tracking) .....	17-23
Plan-in-Hand .....	17-20, 17-21, 17-25, 17-26, 17-34, 17-37, 17-38, 17-39, 17-45
Plan-in-Hand Report.....	17-20, 17-26, 17-34, 17-40
Priority Commercial System Shoulder Width .....	17-28
Practical Design .....	17-17
Project Templates .....	17-19
Railroads.....	17-37
Raised Medians .....	17-26
Right-of-Way .....	17-43
Roadside Barriers .....	17-34
Roadside Geometry (Side Slopes) .....	17-30
Rumble Strips.....	17-33
Seeding .....	17-48
Shoulder Construction.....	17-28
Side Slopes .....	17-30
Spiral Transitions .....	17-23
Stopping Sight Distance .....	17-21
Superelevation .....	17-23
Super 2 Projects.....	17-12
Surfacing Equivalent .....	17-3
Surfacing Taper Rate .....	17-22, 17-33
Surfacing Quantities .....	17-33
Traffic.....	17-43
Transverse Slopes .....	17-25, 17-30
Traveled Way .....	17-28
Turn Lanes.....	17-31
2 + 2 Projects .....	17-11
Utilities .....	17-39
Vertical Alignment Design .....	17-21
Wetlands .....	17-42
Retaining Walls (MSE Wall) .....	6-32, 10-22, 12-26
Fencing Behind Retaining Walls.....	10-22
Reverse Curves .....	3-3
Revised Sheet.....	11-35
Revisions .....	2-33, 11-30, 15-6
Added Sheet .....	11-35
Deleted Sheet .....	11-36
Detail Sheet .....	11-36
Procedures.....	11-33
Project Rejected or Withdrawn From a Letting .....	11-42
Quantity and/or Pay Item Changes.....	11-36
Revised Sheet.....	11-35
Right-of-Way Revisions.....	15-6

<b><i>SUBJECT</i></b>	<b><i>PAGE NUMBER</i></b>
<b>R</b>	
Right-of-Way .....	6-30, 15-1, 17-43
Right-of-Way Acquisition .....	15-19
Right-of-Way Certification .....	15-20
Right-of-Way Preliminary Cost Estimates.....	12-12
Fencing .....	12-13
Improvement Values .....	12-13
Other Right-of-Way Costs .....	12-13
Relocation Assistance .....	12-13
Rural Land Values.....	12-12
Urban Land Values .....	12-12
Right-of-Way Design (New).....	15-4
Right-of-Way Design Plans (W) .....	15-1
Appraisal Plans .....	15-5
Corridor Protection Plans .....	15-2
Negotiation Plans .....	15-5
Ownership Plans .....	15-3
Preliminary Right-of-Way Design.....	15-3
PS&E Plans .....	15-6
Revisions .....	15-6
Right-of-Way Design Review (Preliminary) .....	2-27, 15-5
Right-of-Way Markers .....	15-24
Right-of-Way Plan Sheets .....	11-28, 15-1
Right-of-Way Survey .....	15-1
Right-of-Way for Temporary Roads.....	14-7
Rigid Pavement.....	See Concrete Pavement
Risk Based Project (RBP) .....	1-32, 11-32, 12-4, 15-20, 15-21
Roadside Barriers .....	5-8, 9-1, 17-34
Roadside Geometry (Side Slopes).....	6-26, 17-30
Roadside Safety Analysis Program (RSAP) .....	9-4, 17-34
Roadway Cross-Section Sheets.....	11-29
Roadway Design (Activity 5325/5327).....	2-25
Roadway Design Review/Limits of Construction Plans (Activity 5335/5336) .....	2-25
Roadway Functional Design (Activity 5316/5326) .....	2-12
Roadway Grading .....	7-17

<b><i>SUBJECT</i></b>	<b><i>PAGE NUMBER</i></b>
<b>R</b>	
Roadway Lighting .....	10-31
Costs.....	10-32, 10-33
Festoon Outlets.....	10-32
Guidelines for the Installation of Roadway Lighting .....	10-31
Interchange Lighting.....	10-33
Plans .....	11-26
Rural Continuous Lighting .....	10-33
Rural Intersection Lighting.....	10-32
3R Projects .....	17-11, 17-38
Urban Lighting.....	10-31
Roadway Signs .....	4-27, 14-3
Minimum Vertical Clearance for Overhead Signs .....	3-38
Roadway Transitions.....	6-19, 6-22, 8-10, 14-8
Roller Coaster Profile .....	3-39
Rolling Terrain.....	1-8
Rollover Rates .....	5-20, 6-22
Roundabout Intersections .....	4-3, 10-19, 16-2
Rounding of Pavement Item Quantities .....	12-29
Routine Maintenance .....	1-14
RRZ (Rail Highway Crossings).....	12-3
RSAP (Roadside Safety Analysis Program) .....	9-4, 17-34
Rumble Strips .....	8-13, 17-33
Runoff Length (Superelevation) .....	3-6, 3-40
Rural Context.....	1-19
Rural Driveways.....	4-36
Culvert Pipes.....	4-39
Earthwork.....	4-36, 7-17
3R Projects .....	17-25
Rural Intersections .....	4-16
Design Vehicle .....	4-25
Intersection Radius .....	4-25
Lighting .....	10-31
Offset Right-Turn Lanes .....	4-32, 17-31
3R Projects .....	17-25
Turn Lanes.....	4-27
Rural Land Values .....	12-12
Rural Median Maintenance Turnarounds .....	10-24
Rural Plan Sheet Scales .....	11-11
Rural Town Context .....	1-19
<b>S</b>	
Safe Drinking Water Act.....	13-17
Safety Improvement Projects .....	1-17
Sag Vertical Curves .....	3-34
Salvage and Place Topsoil.....	12-27
Salvaging Items .....	12-4
Sawing Pavement.....	8-13
Scales (Plan Sheets).....	11-11

<b><i>SUBJECT</i></b>	<b><i>PAGE NUMBER</i></b>
<b>S</b>	
Schedule of Cost Estimates .....	12-7
Scoping Changes.....	2-5
Section 404 Permits.....	13-8, 13-14
Section 10 of the Rivers and Harbors Act.....	13-15
Seeding (3R Projects).....	17-48
Semi-Rigid Guardrail (W-Beam and Thrie-Beam) .....	9-5, 9-27
Settlement (Earthwork) .....	7-30, 7-32
Shared Use Paths.....	16-4
Shear Lines (Earthwork) .....	7-13
Shoulders.....	6-2, 8-6
Asphalt Shoulders .....	8-6
Concrete Shoulders.....	8-6
Priority Commercial System .....	6-2
Rollover Rates.....	5-20, 6-22
Shoulder Construction (Earth).....	8-6, 12-27
Shoulder Construction (3R Projects) .....	17-28
Shoulder Cross Slopes.....	6-5
Shoulder Subgrade Preparation .....	12-27
Shoulder Width and Type .....	6-2
Shoulder Width for Lateral Offset to Obstruction .....	1-23
Side Slopes.....	6-26, 17-30
Sidewalks .....	16-5
Curb Ramps.....	16-8
Design Considerations .....	16-5
Fencing at Steep Slopes .....	16-6
Handrails for Pedestrian Ramps and Stairs.....	16-12
Municipal Cost Share .....	16-15
Pedestrian Crosswalks.....	4-27, 14-3, 16-7
Pedestrian Ramps.....	16-11
Pedestrian Underpass.....	16-7
Sight Distance.....	1-18, 3-1
Intersection Sight Distance.....	4-19, 17-11, 17-25
Passing Sight Distance .....	3-33
Stopping Sight Distance .....	3-32, 3-34, 17-21
Temporary Road Sight Distance.....	14-8
Underpass Sight Distance .....	3-38, 5-14
Signal Control .....	4-34
Signalized Intersections .....	4-35, 14-5
Sign Supports .....	12-27
Signs .....	3-38, 4-27, 14-3
Simple Curves.....	3-2
Single Point Urban Interchange .....	5-15
6 (f) Lands.....	13-7
Skew Angle (Intersection) .....	4-20
Skewed Structures.....	10-7
Smoothing of Pavement Edge Profile.....	3-7
Snow Control .....	6-32, 10-20
Social, Economic and Environmental Impacts.....	13-19

<b><i>SUBJECT</i></b>	<b><i>PAGE NUMBER</i></b>
<b>S</b>	
Soil and Materials Survey Information Sheet.....	11-20
Soil, Subgrade and Situation Reports .....	7-29
Embankment Foundation Report.....	7-31
Soil Survey/Soil Situation Report.....	7-29
Subgrade Survey/Subgrade and Situation Report.....	7-30
Sole Sourcing .....	12-17
Special Ditches .....	6-30, 7-7, 7-11, 11-8
Special Plans .....	11-5
Special Provisions.....	2-13, 12-15, 16-15
Specifications.....	12-15
Spiral Transitions .....	3-3, 5-24
3R Projects .....	17-23
Splitter Island .....	4-4, 6-17
Staged Construction/Phasing (Earthwork).....	5-3, 7-9
Standard Notes.....	11-7
Drainage and Hydraulic Information .....	11-10
Horizontal Alignment Data.....	11-8
Individual Construction Notes.....	11-7
Tabular Notes.....	11-7
Vertical Alignment Data.....	11-9
Standard Pay Items .....	12-16
Standard Symbols.....	11-7
Standard Typical Cross-Section Sheet.....	11-6
Standard Plan Formats .....	11-7
Standard Plans .....	11-5
Standardized Special Plans .....	11-5
Standards (Design).....	1-3
State Agencies.....	13-22
State Highway Functional Classification Map (Nebraska) .....	1-4
Statewide Transportation Improvement Program (STIP) .....	12-4
Station Equations.....	3-40, 11-9
Statutory Authority .....	1-1
Steps and Stairs.....	16-12
STIP (Statewide Transportation Improvement Program) .....	12-4
Stop Control.....	4-20, 4-34
Stopping Sight Distance.....	3-32, 3-34, 14-8
Headlight Distance .....	3-34, 3-38
Strategic Highway Network (STRAHNET).....	1-9
Subdrains (Pavement) .....	8-5



<b><i>SUBJECT</i></b>	<b><i>PAGE NUMBER</i></b>
<b>S</b>	
Subgrade Preparation .....	12-27
Subgrade Stabilization .....	12-27
Subgrade Survey/Subgrade and Situation Report.....	7-30
Subsidiary Earthwork .....	7-17
Suburban Context .....	1-20
Summary of Quantities Sheet .....	11-20
Superelevation .....	3-5
Axis of Rotation .....	3-6
Bridge Structures .....	10-6
Maximum Superelevation Rate .....	3-5
Runoff Length.....	3-6
Smoothing of Pavement Edge Profile.....	3-7
Spiral Transitions .....	5-24, 3-3, 17-23
3R Projects .....	17-23
Tangent Runout .....	3-6
Transition Length .....	3-6
Temporary Roads .....	14-8
Super 2 Projects .....	17-12
Surfacing.....	8-1
Intersections and Driveways.....	4-43
Interstate .....	5-3
Mailbox Turnouts.....	10-23
Quantity Computations .....	8-11, 17-33
Railroad/ Highway Crossing .....	10-3
Removal.....	8-9
Surfacing Aggregates.....	8-4, 8-12
Taper Rate .....	8-10, 17-22, 17-33
Temporary Roads .....	14-7, 14-9
Under Guardrail.....	9-17
Surfacing Elevations & Grades .....	11-22
Surfacing Equivalent (3R Projects).....	17-3
Surfacing/Pavement Item Quantities .....	See Pavement Item Quantities
Surfacing Under Guardrail .....	9-17
Survey (Right-of-Way).....	15-1
System Preservation .....	1-12

<b><i>SUBJECT</i></b>	<b><i>PAGE NUMBER</i></b>
<b>T</b>	
Tabular Notes .....	11-7
Tangent Cross Slopes (Travel Lanes).....	6-2
Tangent Runout .....	3-6
Taper Rate (Surfacing).....	8-10, 17-22, 17-33
Template Correction.....	8-10
Temporary Easements.....	15-4
Temporary Roads .....	12-23, 14-7
Right-of-Way .....	14-7
Temporary Access .....	12-28
Temporary Access (ADA) .....	16-13
Temporary Railroad Crossings/Signals (Railroad Involvement).....	12-26
Temporary Shoring .....	12-28
Temporary Surfacing .....	14-7, 14-9
Terrain .....	1-18
Three-leg Intersection .....	4-2
3R Projects .....	See Resurfacing, Restoration and Rehabilitation Projects
Thrie-Beam Guardrail.....	9-5, 9-13
Tining.....	8-4
Title Sheet.....	11-18
Traffic Control .....	4-34, 14-6
Signalized Intersections .....	4-35
Traffic Control Studies.....	14-2
Unsignalized Intersections.....	4-34
Traffic Control Items (Preliminary Cost Estimates).....	12-19, 12-28
Traffic Control Studies.....	14-2
Traffic Engineering Review .....	2-8, 17-43
Traffic Engineering Studies .....	14-1
At-Grade vs Interchange Recommendations.....	14-2
Capacity Analysis.....	14-1
Lane Configuration.....	14-2
Pedestrian Crossings .....	14-3
Safety Analysis.....	14-1
Traffic Control Studies.....	14-2
Volume Studies.....	14-2
Weaving Section Analysis .....	14-2
Traffic Plan Sheets.....	11-26
Traffic Signals .....	4-35, 12-19, 12-28, 14-5
Pedestrian Crossing Signals .....	14-5
Traffic Through Construction.....	14-6
Transit Services .....	4-26
Transitions for Temporary Roads.....	14-8
Transition Lengths	
Auxiliary Lanes.....	4-31, 6-22
Superelevation .....	3-6
Transverse Slopes .....	6-27, 17-25, 17-30

<b><i>SUBJECT</i></b>	<b><i>PAGE NUMBER</i></b>
<b>T</b>	
Travel Lanes .....	6-2
Cross Slopes .....	6-2
Widths .....	6-2
Tree Planting and Removal .....	10-19
Trenched Widening .....	12-28
Turn Lanes .....	4-27, 17-31
Free-Flow Right-Turn Lanes .....	4-34
Offset Right-Turn Lanes .....	4-32
Turn Lane Bay Taper Rate .....	4-31
Turn Lane Length .....	4-31
Two-Way Left-Turn Lanes .....	4-28, 4-51
Twenty-eight Foot Top System .....	1-11
2 + 2 Projects .....	17-11
Two-Way Left-Turn Lanes .....	4-28, 4-51
Type _ Median Break .....	4-53
Typical Cross-Section Sheets .....	11-6, 11-18
Typical Roadway Cross-Sections (Interstate) .....	5-3
Typical Roadway Cross-Sections (3R Projects) .....	17-27
<b>U</b>	
Unchannelized Intersections .....	4-2
Undercutting (Earth Shoulder Construction, Trimming of Subgrade) .....	8-6
Underground Electrical Power and Communication Lines .....	10-28
Underpasses .....	6-33
Pedestrian Underpasses .....	16-7
Underpass Roadways .....	5-14
Roadway Cross-Section .....	5-14
Sight Distance .....	3-38, 5-14
Vertical Clearance .....	3-38, 5-14
Underpass Sight Distance .....	3-38, 5-14
Unsignalized Intersections .....	4-34
Unsuitable Materials .....	7-10
Unusual Circumstances (Cost Estimating) .....	12-28
Urban Context .....	1-20
Urban Core Context .....	1-20
Urban Driveways .....	4-41
Urban Intersections .....	4-16, 4-25
Urban Land Values .....	12-12
Urban Lighting .....	10-31
Urban Plan Sheet Scales .....	11-11
Uses of Cost Estimates .....	12-1
Agreements .....	12-2
Bid Comparison and Analysis .....	12-2
Design Alternatives .....	12-2
NEPA .....	12-2
Planning, Allocation, and Funding .....	12-1
Railroad Protective Liability .....	12-2

***SUBJECT*** ***PAGE NUMBER***

**U**

Utilities.....	2-9, 2-28, 5-8, 6-33, 10-25, 12-5, 12-14, 12-28, 17-39
Aerial Lines .....	10-27
Cost Estimates (Preliminary).....	12-14, 12-28
City/County Utility Cost Reimbursement.....	10-26
Funding.....	12-5
Minimum Vertical Clearances for Overhead Facilities.....	3-38
Pipelines .....	10-29
Underground Electrical Power and Communication Lines .....	10-28
Utility Accommodation on State Right-of-Way .....	10-26
Utility Liaison.....	10-25
Utility Permits on CICS1 .....	2-7, 10-26
Utility Rehabilitation Plan Review .....	10-25
Utilities on Urban Projects .....	2-9, 12-28
Water Mains.....	10-30

**V**

Vertical Alignment	
Combination of Horizontal and Vertical Alignment.....	3-39
Preliminary Vertical Alignment Design (Bridge Hydraulics).....	2-4
Railroad / Highway Grade Crossings.....	10-2
3R Vertical Alignment Design.....	17-21
Vertical Alignment Data.....	3-40, 11-9
Vertical Alignment Design .....	3-21
Vertical Alignment (Profile) at Intersections and Driveways .....	4-24
Vertical Clearances.....	3-38, 5-14, 10-8, 10-27
Vertical Curves.....	3-24
Bridge .....	10-8
Crest Vertical Curves .....	3-32
Crest Vertical Curves, Stopping Sight Distance.....	3-32
Crest Vertical Curves, Passing Sight Distance .....	3-33
Design.....	3-26
Sag Vertical Curves.....	3-34
Sag Vertical Curves, Comfort Criteria.....	3-38
Sag Vertical Curves, Underpass Sight Distance.....	3-38
3R Projects .....	17-21
Vertical Curve Computations.....	3-24
Vertical Curve with Obstructions.....	3-38
Vertical Taper Rate (Surfacing).....	8-10, 17-22, 17-33
Volume Studies.....	14-2

<b><i>SUBJECT</i></b>	<b><i>PAGE NUMBER</i></b>
<b>W</b>	
W-Beam Guardrail .....	9-5, 9-13
W-Beam to Thrie-Beam Guardrail Transition Section.....	9-20
Walls (Retaining).....	6-32, 9-3, 10-22
Waste Sites.....	7-7
Waste Alternatives .....	7-8
Water Mains.....	10-30, 12-14
Water Quality .....	5-8, 13-17
Waterway Permits	
Floodway/Floodplain Permit .....	13-16
Nationwide Permit (NWP) .....	13-14
“No Rise” Certificate .....	13-16
Section 404 Permits .....	13-8, 13-14
Weaving Section Analysis .....	14-2
Weigh Stations.....	5-9
Wetlands.....	12-28, 13-8
Public Notification of Wetland Mitigation.....	13-12
3R Projects .....	17-42
Wetlands Definitions.....	13-8
Wetlands Procedures .....	13-8
Wildlife Issues .....	13-18
Work Zone Significant Projects .....	14-12
Working Days for Construction (Estimated).....	2-27
<b>Y</b>	
Yield Control .....	4-34

