

# Construction Manual

1998 Version  
2000 Update

*March, 2000*

Page	Para.	Action	Description
TOC 100	All	<b>Change/Add</b>	Changed 102.06 title and page number of 106.08 changed.
TOC 400	All	<b>Change</b>	Method of Measurement changed page number.
TOC 500	All	<b>Change</b>	Wording in titles were changed.
TOC 1000	All	<b>Add</b>	Added 1003.04.
TOC 1200	All	<b>Change/Delete</b>	Changed title of 1200.02 and delete 1200.03 and changed 1200.04 to 1200.03
12	5-8	<b>Delete/Add</b>	Deleted paragraphs and added new requirement for plan errors.
16a	1	<b>Add</b>	Added new text requiring Project Development to be notified when construction acceptance date is established.
29	14	<b>Delete/Add</b>	Deleted old wording and added new text "week of July 15 only".
33	10	<b>Delete/Add</b>	Deleted old wording and added new text.
33	12	<b>Add</b>	Added new paragraph on SiteManager requirement for railroad insurance.
37	5	<b>Add</b>	Added railroad phone number listing.
40	4	<b>Delete/Change</b>	Deleted old forms and changed office.
57	3, 4 & 7	<b>Delete</b>	Deleted reference to obsolete Form 203 DBE – Performance Record.
58	6	<b>Delete</b>	Deleted reference to Form 203.
59	3	<b>Add</b>	Added new text which eliminated DR Form 440, EEO Compliance Record.
60	2	<b>Delete</b>	Deleted sentence.
81	2	<b>Change</b>	Changed approval authority on CO/SA.
126	5, 6, & 7	<b>Add</b>	Added new text on finaling project.
127	1	<b>Change</b>	Final Records now on Page 127.
129	2	<b>Add</b>	Added new text explaining how to pay for earthwork as E.Q.
136	4	<b>Delete</b>	Deleted wording.
136	13	<b>Add</b>	Added new sentence on trucking subcontracts.
141	9	<b>Add</b>	Added new text requiring labels on final document submission.
143-143a	5	<b>Add</b>	Added new text on how to handle protesting final earthwork quantities.
144	1	<b>Change</b>	This page now on page by itself.
180	15	<b>Add</b>	Added new text on stabilize subgrade.
212	5	<b>Add</b>	Added new text.
212	9	<b>Delete/Add</b>	Deleted old paragraphs and added new paragraph on flagger requirements.
213	2	<b>Change</b>	Method of Measurement moved to this page.
239	6,7 & 14	<b>Change/Add</b>	Changed words and added new description of unstable areas.

<b>Page</b>	<b>Para.</b>	<b>Action</b>	<b>Description</b>
240	6,7,9 & 10	<b>Delete/Add</b>	Added titles in bold and changed wording for clarification.
241	2,7 & 11	<b>Delete/Change</b>	Deleted wording and changed numbers of tack coat dilution.
242	11-14	<b>Change/Add</b>	Changed wording and added "asphaltic concrete".
243	2, 3, 4, 5, 8, 9 & 10	<b>Change/Add</b>	Changed wording for clarification of AC work.
244	4, 8 & 10	<b>Change/Add</b>	Changed wording for clarification of AC work.
245	5, 6, 7, 8 & 10	<b>Change/Add</b>	Changed wording and added one word for clarification of AC work.
246	9-13	<b>Delete</b>	Deleted paragraphs.
247	1-6 & 7	<b>Delete/Add</b>	Deleted paragraphs and added a paragraph requiring milled rumble strips.
255	6-12	<b>Change/Add</b>	Changed asphalt cement to "performance graded binder."
256	1, 2, 3, 4, 6, 7, 8, 9, 10 & 11	<b>Change</b>	Changed asphalt cement to "performance graded binder."
258	2	<b>Change</b>	Changed asphalt cement to "performance graded binder."
267	5	<b>Delete</b>	Deleted use of orchard sprayer.
301	5	<b>Delete/Add</b>	Deleted old wording and added new text on curing compound.
320	8	<b>Add</b>	Added new wording at end of 3.
322	2	<b>Add</b>	Added new wording in 4.
323	4	<b>Add</b>	Added new wording in 6.
324	1	<b>Add/Change</b>	Added new wording in 6. and changed 6. to 7.
325	5	<b>Add</b>	Added new word.
326	2	<b>Delete/Add</b>	Deleted wording and added new text in 9.
326	2	<b>Delete/Add</b>	Deleted word and added new text in 11.
327	3	<b>Add</b>	Added new word.
329	14	<b>Add</b>	Added new wording on unstable material.
330	6	<b>Delete/Add</b>	Deleted wording at end of paragraph and added new text for clarification.
330	7	<b>Add</b>	Added new text at end of paragraph for clarification.
331	4	<b>Change</b>	Moved concrete seal course to this page.
334	6	<b>Delete/Add</b>	Deleted wording and added new text on piles.
334	12 & 13	<b>Delete</b>	Deleted paragraphs on pile cutoff.
335a-l	All	<b>Add</b>	Added new text on pile work.
335j	Picture	<b>Add</b>	Added drawing of hammer.
337	13	<b>Added</b>	Added requirement on falsework movement.
340	8	<b>Delete</b>	Deleted wording in two places in paragraph for clarification.
345	4 & 5	<b>Add</b>	Added new text on falsework movement.
363	4	<b>Delete/Add</b>	Deleted old wording and added new text on concrete diaphragms.
384	17	<b>Change</b>	Changed temperature number.
389	4	<b>Change</b>	Changed feet amount.
389	9	<b>Add</b>	Added new text on concrete vibration.
390	4	<b>Change</b>	Changed temperature numbers.

<b>Page</b>	<b>Para.</b>	<b>Action</b>	<b>Description</b>
390	6	<b>Delete</b>	Deleted paragraph on plastic over wet burlap.
390	8	<b>Change</b>	Changed temperature numbers.
390	10	<b>Change</b>	Changed temperature number.
391	4	<b>Change</b>	Changed temperature number.
391	7	<b>Delete/Add</b>	Deleted wording and added new text.
392	1 & 2	<b>Delete/Add</b>	Deleted wording and added new text on when to cast deck.
392	6	<b>Add</b>	Added new text at end of paragraph on how to retard set.
393	9	<b>Delete/Add</b>	Deleted wording and added new text on free fall of concrete.
397	7	<b>Change</b>	Changed wording for clarification.
398	1	<b>Add</b>	Added new text.
398	2	<b>Delete</b>	Deleted paragraph.
401	8	<b>Delete</b>	Deleted wording on old curing procedures.
401	9	<b>Add</b>	Added new paragraph on new curing procedures.
401	10	<b>Delete</b>	Deleted paragraph.
401	11	<b>Add</b>	Added new paragraph on tining.
403	13	<b>Delete/Add</b>	Deleted wording and added new text on rail cracks.
403	15	<b>Delete/Add</b>	Deleted word and added new word.
404	6-11	<b>Delete</b>	Deleted paragraphs on mobile mixer.
406	3-9	<b>Delete</b>	Deleted paragraphs that were duplicated.
407	1-2	<b>Delete</b>	Deleted paragraphs that were duplicated.
407	5	<b>Delete</b>	Deleted wording.
407	13	<b>Change</b>	Changed temperature number.
408	9-11	<b>Add</b>	Added new text on limits of tining.
409	3, 4 & 5	<b>Delete/Add</b>	Deleted wording and added new text on curing.
409	6 to end	<b>Add</b>	Added new text on ways to avoid cracks.
409a	1	<b>Add</b>	Added new text on ways to avoid cracks.
410-410a	13	<b>Moved</b>	Moved from Page 412.
411	2	<b>Moved</b>	Moved text to Page 418.
412	2	<b>Moved</b>	Moved text to Page 410.
413	1-4	<b>Add</b>	Added new text on simultaneous casting of deck and approaches.
413a	All	<b>Moved</b>	Extended over from Page 413.
416	6	<b>Delete</b>	Deleted word.
418	11	<b>Moved</b>	Moved Placing Cement and Form Removal from Page 410.
418a	All	<b>Moved</b>	Extended over from Page 418.
420	7 & 8	<b>Add</b>	Added 07 in paragraph 7 and new next in paragraph 8.
422	7	<b>Add</b>	Added 07 in paragraph number.
422	12	<b>Delete/Add</b>	Deleted word and added word.
424	All	<b>Delete</b>	Deleted table and rest of page on broken back calculations.
470	9	<b>Add</b>	Added wording.
481	8-10	<b>Add</b>	Added 1003.04 Cement Certification.
527	3	<b>Change</b>	Changed title of 1200.02 to Informational Guidance.
527	5	<b>Delete</b>	Deleted paragraph.
527	6-10	<b>Add</b>	Added new paragraphs and deleted 1200.03 heading and added sentence at end of paragraph 10 for SiteManager clarification.
528	All	<b>Delete</b>	Deleted old page and replace with new 528.
528a-b	All	<b>Add</b>	Added new pages with SiteManager Support List.

<b>Page</b>	<b>Para.</b>	<b>Action</b>	<b>Description</b>
532	2-end	<b>Add</b>	Added new text on surveying requirements.
562	3	<b>Delete/Add</b>	Deleted wording and added new text for clarification.
Appendix 1-1	5	<b>Delete</b>	Deleted two DR Forms.
Appendix 1-1	5	<b>Change</b>	Changed 289 to 298.
Appendix 1-2	10	<b>Add</b>	Added 50/504 to RDP.
Appendix 1-3	6	<b>Delete</b>	Deleted DR Form.
Appendix 1-18	All	<b>Delete</b>	Deleted form.
Appendix 1-19	All	<b>Delete</b>	Deleted page.
Appendix 1-26	All	<b>Delete</b>	Deleted form.
Appendix 1-85	All	<b>Delete</b>	Deleted form.
Index 1-16	All	<b>Change/Add</b>	Changed page numbers and additions.

## DIVISION 100

### CONTRACT ADMINISTRATION & INSPECTION PROCEDURES

<b>101.00</b>	<b>CONSTRUCTION ORGANIZATION.....</b>	<b>1</b>
	101.01 PURPOSE OF MANUAL.....	1
	101.02 ENGINEER'S DUTIES AND AUTHORITY .....	1
	Authority of the Director-State Engineer.....	1
	General.....	1
	Delegation of Authority .....	1
	General.....	1
	101.03 CONSTRUCTION DIVISION.....	2
	101.04 CHAIN OF COMMAND.....	4
	101.05 CONSTRUCTION ENGINEER.....	4
	Interpretation of Specifications .....	4
	101.06 DISTRICT ENGINEER (DE).....	5
	101.07 DISTRICT CONSTRUCTION ENGINEER (DCE).....	5
	101.08 PROJECT MANAGER (PM) .....	6
	Delegation of Responsibility.....	7
	101.09 CONSTRUCTION TECHNICIAN (CT).....	7
<b>102.00</b>	<b>GENERAL RESPONSIBILITIES .....</b>	<b>9</b>
	102.01 PROMPT EXERCISE OF AUTHORITY .....	9
	102.02 APPEALED DECISIONS .....	9
	102.03 INTEGRITY OF EMPLOYEES .....	10
	Removing Materials from Projects .....	11
	102.04 PRESENCE ON SITE .....	12
	102.05 PLANS AND WORKING DRAWINGS.....	12
	102.06 PLAN ERRORS/OMISSIONS .....	12
	102.07 ENGINEER RELATIONS .....	13
	102.08 PUBLIC RELATIONSHIPS .....	13
	General Project Supervision.....	13
	Residents Along Construction Projects.....	13
	Services Relationships.....	13
	News Media Relationships.....	14
	Relations with Cities and Counties.....	14
	102.09 CONTRACTOR (PARTNERING) RELATIONSHIPS.....	15
	102.10 FHWA & OTHER OUTSIDE AGENCIES RELATIONSHIPS.....	15
	102.11 EMPLOYMENT OF CONSULTANTS FOR CONSTRUCTION ENGINEERING AND INSPECTION.....	16
	Agreement Responsibilities.....	16
	Project Manager.....	16
	102.12 PERSONNEL.....	17
	102.13 EMPLOYEE POLICIES.....	17
	102.14 STAFF REQUIREMENTS .....	17
	Field Estimates .....	17
	Adjustments.....	17
	Field Personnel Duties & Staff Requirements .....	17

@

102.15	SUBCONTRACTS .....	18
	Subcontract Request And Approval.....	18
102.16	DETOUR REPORT .....	24
102.17	CONTROL NUMBERS AND CONTRACT NUMBERS.....	24
<b>103.00</b>	<b>PRECONSTRUCTION.....</b>	<b>25</b>
103.01	PRECONSTRUCTION CONFERENCE .....	25
103.02	ADMINISTRATION DETAILS.....	26
103.03	PROJECT DETAILS .....	32
103.04	ADDITIONAL TOPICS FOR DISCUSSION.....	35
103.10	ONE CALL NOTIFICATION.....	37
	Fiber Optic Cable Buried on Railroad Right-of-Way.....	37
103.11	UTILITIES AND RAILROAD REHABILITATION.....	37
	General.....	37
	Preventing Damage to Utility Properties.....	37
	Beginning Rehabilitation.....	38
	Inspecting Rehabilitation Work.....	38
	Scrap Utility Material.....	37
103.12	HAUL ROADS.....	39
103.20	CONTRACT ADMINISTRATION.....	40
103.21	NEBRASKA & FHWA FORMS & REPORTS - PREPARED BY CONTRACTOR.....	40
103.22	OCCUPATIONAL SAFETY AND HEALTH.....	41
103.23	EQUAL EMPLOYMENT OPPORTUNITY (EEO) .....	42
	Contractor's Responsibility.....	42
	Project Manager Involvement .....	42
103.24	TRAINING & TRAINEE PROGRAMS .....	44
	Contractor's Responsibility.....	44
	Project Manager's Involvement .....	46
103.25	WAGES AND EMPLOYMENT .....	47
103.26	DAVIS-BACON AND RELATED ACTS REQUIREMENTS (Payrolls).....	49
103.27	DISADVANTAGED BUSINESS ENTERPRISE (DBE) SUBCONTRACTOR...	54
103.28	LEASE OF PROPERTY BEYOND THE HIGHWAY RIGHT-OF-WAY.....	59
103.29	CONTRACTOR'S USE OF HIGHWAY RIGHT-OF-WAY .....	59
103.30	"CONTRACT QUANTITIES" .....	59
103.31	CONTRACTOR'S SALES TAX EXEMPTION.....	60
103.40	FREIGHT RATES .....	61
103.50	BARRICADES, DANGER, WARNING AND DETOUR SIGNS.....	62
103.60	SAFETY AND HEALTH REGULATIONS FOR CONSTRUCTION.....	63
103.61	RESPONSIBILITY OF CONTRACTOR .....	63
	Safety Inspections.....	63
	Postings .....	63
	Checklist Safety Program .....	63

<b>104 CONSTRUCTION INSPECTION .....</b>	<b>66</b>
<b>104.01 CONTRACT TIME DETERMINATION .....</b>	<b>66</b>
Tentative Beginning Date.....	66
Notice to Proceed .....	66
Beginning the Counting of Working Days.....	67
Working Day.....	67
Working Day Report and Diary Record .....	69
<b>104.02 CHARACTER OF WORKPERSONS, METHODS, AND EQUIPMENT .....</b>	<b>70</b>
<b>104.03 TEMPORARY SUSPENSION OF WORK.....</b>	<b>71</b>
Specification Provisions .....	71
Specialty Items, Time Suspensions.....	71
<b>104.04 PROGRESS OF WORK .....</b>	<b>73</b>
<b>104.05 WINTER WORK.....</b>	<b>74</b>
<b>104.06 WEEKLY REPORT OF WORKING DAYS.....</b>	<b>74</b>
<b>104.07 RENTAL RATE GUIDELINES.....</b>	<b>75</b>
<b>104.08 CHANGE ORDER - SUPPLEMENTAL AGREEMENTS .....</b>	<b>79</b>
Policy for Change Orders.....	79
Subcontracted Items .....	79
Contract Unit Price .....	79
Change Order Approval Limits .....	80
Cost Overrun/Underrun Notification Letters .....	85
Work Orders.....	85
Force Account Agreements and Statements .....	86
Force Account Agreements .....	86
Force Account Statements .....	88
Alterations of Plans or Character of Work.....	89
<b>104.09 VALUE ENGINEERING .....</b>	<b>90</b>
<b>104.10 PLANT INSPECTION.....</b>	<b>92</b>
<b>104.11 PLANT REPORTS .....</b>	<b>93</b>
<b>104.20 FIELD TESTS .....</b>	<b>94</b>
<b>104.21 FIELD TESTING ON CONSTRUCTION PROJECTS .....</b>	<b>94</b>
Materials.....	94
Project Acceptance Sampling and Testing.....	94
Assurance Sampling and Testing.....	94
<b>104.30 TRUCKS/HAULING OF MATERIALS.....</b>	<b>95</b>
<b>104.40 SCALES .....</b>	<b>96</b>
<b>104.41 SCALE TICKETS.....</b>	<b>96</b>
<b>104.42 TRUCK PLATFORM SCALE APPROVAL.....</b>	<b>97</b>
Truck Platform Scale Use .....	97
<b>104.50 SMOOTHNESS.....</b>	<b>98</b>
<b>104.51 TESTING .....</b>	<b>98</b>
<b>104.52 EVALUATION .....</b>	<b>98</b>
Pavement Smoothness .....	98
Bridge Deck Smoothness .....	98
<b>104.53 BUMP CORRECTION.....</b>	<b>99</b>
<b>104.60 LIQUIDATED DAMAGES &amp; EXTENSION OF CONTRACT TIME.....</b>	<b>99</b>
Liquidated Damages.....	99
Contract Time Extensions.....	99

104.70	ACCIDENTS .....	101
105	MEASUREMENT AND PAYMENT .....	102
105.01	GENERAL.....	102
105.02	MEASUREMENT OF QUANTITIES AND COMPENSATION FOR ALTERED QUANTITIES .....	102
105.03	CANCELLED ITEMS (MATERIALS FURNISHED BY CONTRACTOR AND NOT USED DUE TO CHANGES IN PLANS).....	103
105.04	PARTIAL PAYMENT.....	103
105.05	FIELD MEASUREMENT AND PAYMENT.....	104
	Photographs and Video Tapes .....	104
	Field Records - General .....	104
	Field Notebooks.....	104
	Scale Tickets.....	105
105.06	CONTRACTOR'S ESTIMATES .....	106
	Stockpiling .....	107
	Contractor's Statement of Compliance (Form WH-348).....	108
	Contractor's Statement of Materials and Labor.....	109
105.07	FIELD COMPUTATIONS FOR FINAL PAYMENT.....	109
	General .....	109
	Roadway Excavation .....	109
	Data Collector .....	109
	Planimeter Method.....	110
	Overhaul.....	112
	Foundation Course.....	112
	Gravel Surfacing .....	113
	Prime Coat and Tack Coat .....	113
	Asphaltic Concrete Surface Course and Base Course .....	114
	Concrete Pavement .....	114
	Removal of Existing Structures and Preparation of Existing Structures.....	114
	Removal of Existing Structures.....	114
	Preparation of Existing Box Culverts.....	115
	Excavation for Structures .....	115
	Excavation for Bridges.....	115
	Concrete Seal Course .....	115
	Excavation for Culverts.....	116
	General.....	116
	Typical Channel Section .....	116
	Piles and Pile Driving .....	117
	Sheet Piling.....	117
	Concrete Construction and Reinforcement.....	118
	Culverts .....	118
	Concrete Pipe Culverts .....	118
	Corrugated Metal Pipe and Pipe Arch Culverts .....	119
	Corrugated Metal Pipe.....	119
	Corrugated Metal Pipe Arches.....	119
	Pipe Ordered But Not Used.....	119
	Culvert Pipe.....	120



Sewers.....	120
Excavation .....	120
Pipe Computations.....	120
Guardrail .....	121
Tree Current Retards.....	117
Seeding and Slope Protection.....	121
105.08 BORROW AND LOCAL PIT MATERIALS OBTAINED BY THE CONTRACTOR.....	121
Borrow and Local Pit Materials Furnished by the State or County and Not Involving the Contractor.....	122
105.09 SUMMARY OF FINAL QUANTITIES.....	123
105.10 MOBILIZATION.....	123
Method of Measurement and Basis of Payment.....	123
105.11 SALVAGED PROJECT MATERIALS REPORTING .....	123
106 PROJECT FINALIZATION .....	124
106.01 FINAL PAYMENT TO CONTRACTOR.....	124
106.02 PRICE ADJUSTMENT CHANGE ORDERS.....	124
106.03 EQUIPMENT PURCHASED BY CONSTRUCTION CONTRACTS .....	124
106.04 PROJECT ACCEPTANCE AND AUTHORIZATION FOR FINAL PAYMENT.124	
Notification of Project Completion (DR Form 91) - Federal Aid Projects	125
106.05 FINAL PACKAGE .....	120
106.06 FINAL COMPUTATIONS.....	125
106.07 ACCEPTANCE AND FINAL PAYMENT.....	125
Final Inspection and Acceptance .....	125
Interest Payments on Delayed Estimates .....	126
106.08 FINAL RECORDS.....	127
Introduction.....	127
Right-of-Way .....	127
Crop Damage .....	127
Alternate Crop Damage Procedure .....	124
106.09 STATEMENT OF MATERIALS AND LABOR .....	131
106.10 AS BUILT PLANS.....	132
Clearance Letter .....	136
106.11 OVERRUNS AND UNDERRUNS LETTER .....	136
106.12 CONTRACTOR EVALUATIONS.....	136
Guidelines for Preparation of RDP Form 344; "Evaluation of Contractor (EOC)" .....	138
Completing the Form.....	138
Distribution.....	138
Filling Out the Form.....	138
Line by Line Instructions.....	139
106.13 LETTER OF TRANSMITTAL .....	141
106.14 FINALING PROCEDURES .....	141
Contractor's Estimate, "Additional" .....	142
106.15 UNAUTHORIZED WORK.....	142
106.16 USE OF ADJACENT LAND UNDER CONTRACT OR LEASE.....	142
106.17 FINAL CLEANING UP.....	142

@

<b>106.18 CONSULTANT INSPECTION.....</b>	<b>143</b>
--	------------

## DIVISION 400

### LIGHTING, SIGNS, TRAFFIC SIGNALS & TRAFFIC CONTROL

<b>401.00 LIGHTING CHECKLIST</b> .....	193
SSHC References .....	193
Other References .....	193
<b>402.00 LIGHTING</b> .....	197
<b>402.01 GENERAL INFORMATION</b> .....	197
SSHC References .....	197
Other References .....	197
General Comment.....	197
Special Construction Items .....	197
<b>402.02 PRECONSTRUCTON CONFERENCE</b> .....	197
<b>402.03 SHOP DRAWINGS AND MATERIALS LIST</b> .....	198
<b>402.04 CONSTRUCTION REQUIREMENTS</b> .....	198
Staking of Light Pole and Tower Foundations .....	198
Wood Poles Used on Lighting Projects .....	198
Testing of Lighting Systems.....	198
Poles and Towers.....	199
Poles and Tower Foundations .....	199
Luminaires .....	199
Lighting Control Centers .....	200
High Mast Lowering System .....	200
Temporary Lighting System .....	200
<b>402.05 PAYMENT FOR ELECTRIC POWER USED BY THE LIGHTING SYSTEM</b> .....	201
<b>402.06 COMPLETION -AND ACCEPTANCE OF THE PROJECT</b> .....	201
<b>403.00 TRAFFIC SIGNALS</b> .....	202
<b>403.01 GENERAL</b> .....	202
<b>403.02 PRE-CONSTRUCTION CONFERENCE</b> .....	202
<b>403.03 PRELIMINARY STAKING</b> .....	202
<b>403.04 SAW CUT LOOP LOCATION</b> .....	202
<b>403.05 TEMPORARY SIGNAL</b> .....	202
<b>403.06 ELECTRICAL POWER</b> .....	203
<b>403.07 STATE SUPPLIED MATERIAL</b> .....	203
<b>403.08 SAFETY</b> .....	203
<b>403.09 ITEMS TO CHECK WHEN INSTALLING</b> .....	203
<b>403.10 FINAL SIGNAL TURN ON</b> .....	206
<b>404.00 CONSTRUCTION WORK ZONE TRAFFIC CONTROL</b> .....	207
<b>404.01 TRAFFIC CONTROL SPECIFICATION REFERENCES</b> .....	207
<b>404.02 TRAFFIC CONTROL SIGNING CHANGES</b> .....	207
<b>404.03 CONSTRUCTION ZONE ACCIDENT REPORTING</b> .....	208
Investigation Procedure .....	208
Accident Notification Procedure.....	209
Reporting of Severe Personal Injury and Fatal Accidents.....	209
<b>404.04 STOP SIGNS ON CONSTRUCTION PROJECTS</b> .....	209
<b>404.05 "ROAD WORK AHEAD" AND "END ROAD WORK" SIGNS</b> .....	210
<b>404.06 NO PASSING ZONES ON CONSTRUCTION PROJECTS</b> .....	210

<b>404.07</b>	<b>EQUIPMENT AND MATERIAL STORAGE</b> .....	210
<b>404.08</b>	<b>CONSTRUCTION WORK ZONE SIGNING DURING WINTER SHUTDOWN</b> .....	211
	Uncompleted Projects.....	211
	Multi-Contract Projects.....	211
	Special Concerns.....	212
<b>404.09</b>	<b>FLAGGERS &amp; PILOT CARS</b> .....	212
	Flagger Bid Item.....	212
	Slow/Slow Paddles .....	212
@	Method of Measurement.....	213
<b>404.10</b>	<b>INTERSTATE TRAFFIC CONTROL REQUIREMENTS</b> .....	213
	Median Crossings .....	213
	Traffic Control Removal for Head-to-Head Projects.....	213
	Raised Pavement Markers.....	214
<b>404.11</b>	<b>CHANGEABLE MESSAGE SIGN GUIDELINES</b> .....	214
<b>404.12</b>	<b>FLASHING ARROW PANELS</b> .....	214
<b>404.13</b>	<b>SIGN MOUNTING DEVICES</b> .....	215
<b>404.14</b>	<b>REMOVAL OF TEMPORARY PAVEMENT MARKINGS</b> .....	215
<b>404.15</b>	<b>WORK AREA SPEED ZONE</b> .....	216
	Speed Limits in Maintenance Work Areas .....	216
	Signing.....	218
	Recordkeeping.....	220
<b>404.16</b>	<b>BRIDGE APPROACH GUARD RAILS</b> .....	220
<b>404.17</b>	<b>INERTIAL BARRIER SYSTEMS</b> .....	221
<b>404.18</b>	<b>BARRICADES/PLASTIC DRUMS</b> .....	221
<b>405.00</b>	<b>SIGNS</b> .....	222
<b>405.01</b>	<b>DEDUCTION FOR SIGNS</b> .....	222
<b>405.02</b>	<b>SIGN MAINTENANCE</b> .....	222

# DIVISION 500

## BITUMINOUS PAVEMENT

<b>501.00 ASPHALT PAVEMENT CHECKLIST .....</b>	<b>227</b>
<b>502.00 ASPHALT PAVEMENT .....</b>	<b>232</b>
<b>502.10 ASPHALT PAVEMENT DESCRIPTION.....</b>	<b>232</b>
<b>502.20 ASPHALT PAVEMENT MATERIAL REQUIREMENTS.....</b>	<b>232</b>
<b>502.20.1 ASPHALT ACCEPTANCE AND TESTING .....</b>	<b>232</b>
Field Tests and Certification of Materials .....	232
Asphalt Materials.....	232
Aggregates.....	233
<b>502.20.2 RESPONSIBILITY AND DOCUMENTING ASPHALT MIXTURE</b>	
<b>PROPORTIONING CHANGES.....</b>	<b>233</b>
Adjusting Asphalt Cement Contents.....	233
Documenting Corrective Action for Noncomplying Air Voids Test on Specimens	
Taken from Constructed Pavement.....	233
Adjusting Aggregate Proportions.....	234
Filler-Bitumen Ratio .....	234
<b>502.20.3 ASPHALT REPORT FORMS.....</b>	<b>234</b>
Form Identification and Use .....	235
<b>502.30 ASPHALT PAVEMENT EQUIPMENT .....</b>	<b>236</b>
<b>502.30.1 INSPECTION AT ASPHALT PLANTS .....</b>	<b>236</b>
<b>502.30.2 INSPECTING THE MIXING TIME OF ASPHALT PLANTS.....</b>	<b>236</b>
<b>502.30.3 USE OF SPECIAL EQUIPMENT .....</b>	<b>237</b>
Material Transfer Vehicle.....	237
Mat Smoothness Machine .....	238
Windrow Pick-up Equipment .....	238
<b>502.40 ASPHALT PAVEMENT CONSTRUCTION METHODS.....</b>	<b>239</b>
<b>502.40.1 UNSTABLE SUBGRADES AND SUBBASES .....</b>	<b>239</b>
Locating Unstable Areas .....	239
Determining Cause.....	239
Drying and Recompaction .....	239
Special Treatments .....	240
<b>502.40.2 GRADELINE STRINGS AND EDGE ALIGNMENT .....</b>	<b>240</b>
<b>502.40.3 LONGITUDINAL JOINTS.....</b>	<b>241</b>
<b>502.40.4 TACK COATS USING EMULSIONS.....</b>	<b>241</b>
For Dilution.....	241
Application Rate for Diluted Emulsion .....	241
Sample for Compliance .....	242
Measurement for Pay .....	242
Settlement of Diluted Emulsions .....	242
<b>502.40.5 DENSITY CONTROLS FOR ASPHALTIC CONCRETE .....</b>	<b>242</b>
Procedures for Construction of Test Strips.....	244
Resolving Density - Void Conflicts.....	244
<b>502.40.6 LAYING WIDTHS FOR ASPHALT.....</b>	<b>245</b>

@	<b>502.40.7 PLACEMENT RATES FOR HOT MIX ASPHALT BASES, BINDER, AND SURFACE COURSES .....</b>	<b>245</b>
	<b>502.40.8 COLD WEATHER ASPHALT CONSTRUCTION .....</b>	<b>246</b>
	<b>502.40.9 RUMBLE STRIPS IN ASPHALT SHOULDERS .....</b>	<b>246</b>
	<b>502.40.10 QUALITY CONTROL MONITORING .....</b>	<b>247</b>
	<b>502.50 ASPHALT PAVEMENT METHOD OF MEASUREMENT AND PAYMENT .....</b>	<b>252</b>
	<b>502.50.1 TESTING FOR SMOOTHNESS.....</b>	<b>252</b>
	Incentive/Disincentive Payments for Asphaltic Concrete Smoothness.....	252
	Use of Straightedge .....	254
	<b>502.50.2 CHECKING TRANSVERSE JOINTS FOR SMOOTHNESS.....</b>	<b>254</b>
@	<b>502.50.3 PERFORMANCE GRADED BINDER.....</b>	<b>255</b>
	Tank Measurement and Asphalt Cement Content Determination .....	255
	Measuring Asphalt Binder for Small Quantities .....	256
	Asphalt Cement Quantities and Pay Adjustments.....	256
@	<b>502.50.4 TARGET VALUES FOR ASPHALTIC CONCRETE PRODUCED.....</b>	<b>256</b>
	<b>502.50.5 MEASURING ASPHALT MATERIALS .....</b>	<b>256</b>
	<b>503.00 ASPHALT CURBS .....</b>	<b>257</b>
	<b>504.00 STATE MAINTENANCE PATCHING .....</b>	<b>258</b>
	<b>505.00 P.E.P. GUIDELINES.....</b>	<b>259</b>
	<b>506.00 MILLINGS.....</b>	<b>260</b>

## DIVISION 1000

### MATERIAL DETAILS

1001.00 GENERAL .....	477
1001.01 MATERIAL CERTIFICATIONS .....	477
1001.02 MATERIAL CERTIFICATION RECEIPT & INTEREST DATE DETERMINATION .....	477
1002.00 APPROVED PRODUCTS LIST .....	478
1002.01 DESCRIPTION .....	478
1002.02 ACCESS COMMANDS .....	478
1002.03 ADDITIONS/DELETIONS TO THE APPROVED PRODUCTS LIST.....	479
1003.00 WHITE PIGMENTED CURING COMPOUND AND HOT-POUR JOINT SEALER.....	480
1003.01 DESCRIPTION .....	480
1003.02 ACCESS COMMANDS .....	480
1003.03 REPORTING MATERIAL USAGE .....	481
@ 1003.04 CEMENT CERTIFICATIONS .....	481

## DIVISION 1200

### SITEMANAGER

DIVISION 1200 -- SITEMANAGER .....	527
1200.01 INTRODUCTION.....	527
1200.02 IMPLEMENTATION SCHEDULE <i>INFORMATIONAL GUIDANCE</i> .....	527
<del>1200.03 GUIDANCE</del> .....	527
<del>1200.04 FCAC MEMBERS</del> .....	528
1200.03 <i>SITEMANAGER SUPPORT LIST</i> .....	528

@



beams, samples of aggregates or other materials, and the products of project site clearance.

Complete cleanup of the construction area or plant site, including test materials, is the responsibility of the contractor.

#### **102.04 PRESENCE ON SITE**

As the Department's representative on the project, it is essential that the Project Manager be available at all times to the contractor, his/her subordinates, and the supervisor. The PM should never be absent from the job without his/her whereabouts being known to someone, so that he/she may be contacted if necessary. The Project Manager's absence from the project will certainly compromise his/her efficiency and can be most embarrassing to his/her superiors.

#### **102.05 PLANS AND WORKING DRAWINGS (SSHC 105.02)**

"All authorized alterations affecting the requirements and information given in the approved plans shall be in writing". Such alterations will generally be authorized by revised plans, and the Project Manager should only authorize alterations on that basis.

#### **@ 102.06 CONSULTANT PLAN ERRORS/OMISSIONS**

~~Both the Roadway Design and the Bridge Divisions utilize contracts with consultants for the preparation of construction project plans.~~

~~Every effort should be made during plan review to discover errors in staking layouts, elevations, reinforcing steel quantities, etc. Any project costs resulting from plan errors, such as the removal and reconstruction of an item built according to an erroneous plan, should be reported to the Construction Division for recovery from the consultant.~~

~~County and city engineers should apply this same philosophy to errors in plans by consultants.~~

*The Project Manager, upon discovering or suspecting an error or omission in the plans, will immediately send an e-mail note to the District Construction Engineer and the Construction Division in Lincoln. The note should provide all available information. This would include:*

- *A description of the problem and reasons for concluding a plan error or omission.*
- *The sheet number(s) where the error is located.*
- *What alternatives are available.*

*The Construction Division will contact the Section Head responsible for the work where the error or omission is suspected and determine if a problem exists.*

- *For consultant designed plans, the Section Head must notify the consultant and Project Development's Agreement Engineer if a problem with the plans exist.*
- *The consultant must be included immediately in the discussion and resolution of the problem. They may have a workable and less costly solution.*

*The final solution to the error or omission will be an agreed joint decision by the Construction Division, the District, and the responsible Section Head, and the consultant (when applicable).*

*For consultant designed plans, the District must send the Agreements Engineer a signed copy of the "Contractor Change Order/Supplemental Agreement."*

- @
- *In regard to projects utilizing consultant inspection services, some misunderstandings have arisen when our acceptance date preceded a date when the county board “accepted” the project.*
  - *Consultants utilized for engineering and inspection services must be given written notice regarding project completion dates. The consultant agreements usually specify the time allowed for the preparation and submittal of As-Built Plans and other final records, and the consultants need to be told when the clock has started. The consultant agreements state “The State will provide written notification of construction acceptance to the Consultant.” At least one consultant has reported they do not receive the required notice.*
  - *Feel free to be somewhat flexible in “starting the clock,” but do put it in writing – and **send a copy of the letter to Lee Pavel in Project Development** so that he may begin his end-of-project paperwork, too. The consultant services agreements and payments are audited by the Department, and it is important to have the notification documented.*

J. Right-of-Way

All parties are reminded that highway right-of-way abuts upon private property. Any infringement or trespassing upon such private property could cause damage that would become a liability to the person or organization involved. Maintaining good relations with the public (especially private property owners) is very important.

K. Safety

Contractor must comply with provisions of the Federal and State Occupational Safety and Health Acts.

L. Nebraska One Call Notification System shall be explained by the Project Manager. The Diggers Hotline of Nebraska phone number is 1-800-331-5666.

M. Contractor has 48 hours to file notice with county sheriff when burial sites are discovered.

N. Water Pollution & Wetlands

The contractor's schedule and methods for control of water pollution and protection of wetlands should be reviewed. For more information, refer to Construction Manual Division 1100.

All disposal sites require NDR approval.

O. EEO Requirements (Federal Aid Projects)

1. Forms PR-1391, Manpower reports required. (Distribute sample form)

A. The Contractor (prime and subs) shall send two copies to State Contract Compliance Officer.

B. Submit by 10<sup>th</sup> of August.

C. Needed for the ~~month of July~~ *week of July 15<sup>th</sup>* only.

D. If no minorities or women employed - explain why.

E. Required of subcontractors, also, with subcontract of \$10,000 or more.

2. All subcontract and purchase agreements must include E.E.O. provisions.

A. All sections of Form PR-1273 must be attached to these agreements.

3. Not allowed to maintain segregated facilities of any kind.

4. Must pay comparable wages.

@

Construction Division.

2. Staging Schedule and/or Sequence of Operation.
  3. Items to be sublet and names of subcontractors.
- C. Sampling and material testing requirements shall be discussed.
- D. Contractor Insurance requirements shall be verified.
- E. Railroad Protective Insurance

The contractor must have appropriate insurance in force when working on the railroad right-of-way.

Railroad Protective Insurance for all active projects which require Railroad Insurance is on the CICS-3 computer system under Job 194. You can inquire this information under Function 06.

Project Managers are sometime lax about entering the dates that construction starts and ends on the railroad right-of-way. This needs to be done as soon as possible.

@

In order for this system to be functional, Project Managers need to go into the ~~CICS-3 system under Function 14 and a U (for update) CICS-1 system~~ then go to Function 3. CON Contracts, Agreements, Vendors; then go to Function 2. Construction Status; & finally go to Function 14. RR Insurance Update and enter the date that construction started on the railroad right-of-way. This should be done in a timely manner. **Check to make sure that Railroad Protective coverage is in force.** If not, do not allow the contractor on the right-of-way and do give Controller Division (402-479-4631) a call so that they can verify that insurance has, in fact, not been received. When work has been completed on the railroad right-of-way, the same procedure should be used to record the ending date.

When these steps are all done in a timely manner, the Controller Division will be able to inquire on railroad projects and determine if insurance has been received, whether or not coverage is in force, when work on right-of-way started, and when work on right-of-way was completed, thus no longer requiring Railroad Insurance.

@

*If a project is managed under SiteManager, then Kathy Nuttleman, Controller Division, will enter the effective dates of railroad insurance policies in SiteManager. However, the Project Manager must, in the Key Dates area of SiteManager, record the date that construction started and the date when construction in the railroad right-of-way is complete.*

- Partnering Opportunities (*SSHC Section 113*)
  - ◆ Workshops/Training
  - ◆ Dispute resolution procedures
  - ◆ Meeting schedule/location

**103.10 ONE CALL NOTIFICATION**

**It is the law; anyone who digs a hole, pushes a pipe through the ground, or even moves a stockpile of gravel must contact Diggers Hotline first. The Diggers Hotline phone number is 1-800-331-5666.**

**Fiber Optic Cable Buried on Railroad Right-of-Way**

***Railroad Points of Contact for Location of Fiber Optic Cable***

@ Burlington Northern Santa Fe Railway.....	800-533-2891
Nebraska Central Railroad Company .....	800-336-9193
Nebkota Railway.....	308-282-1550
Nebraska Northeastern Railway Company.....	402-748-3535
Nebraska Kansas Colorado Railnet.....	817-571-2356
Union Pacific Railroad.....	800-336-9193

Most railroad lines have fiber optic cables buried in the right-of-way.

The Union Pacific Railroad has an "800" number available 24 hours a day to determine if fiber optic cable is buried on their right-of-way.

The number is 1-800-336-9193. Anyone calling the "800" number will need to give the railroad milepost number to the operator.

When we have a construction project that may involve railroad right-of-way, a railroad special provision will be added to the bid proposal. The contractor will be required to call the appropriate "800" number before working on railroad right-of-way. The railroad milepost number will be included in the special provision.

Project Managers should confirm that the contractor knows how to get clearances.

**103.11 UTILITIES AND RAILROAD REHABILITATION**

- A. General - Work by utility companies and railroads in making necessary rehabilitation of their facilities for our project construction will often require certain advance preparations by the Project Manager and cooperation with the firm during the progress of their work. In many cases it will be necessary that our right-of-way be defined by setting of stakes prior to beginning rehabilitation work. Grade stakes may be required at railroad crossings or in connection with pipe line or pole line work on the project. The firm involved will generally be responsible for furnishing their own stakes needed for the actual rehabilitation but will need basic information from which to work. Cooperation with these firms will assist in getting their facilities out of the way of our construction.
- B. Preventing Damage to Utility Properties - The Project Manager should document that proper precautions are taken to protect and prevent damage to

**103.12 HAUL ROADS** (*SSHC Section 107*)

Prior to beginning any work, the contractor is required to meet with all involved local governmental entities and advise them of any intentions to use their local roads. The contractor shall be responsible for resolving claims concerning damage to local roads caused by his/her operation.

The contractor shall protect and indemnify the State and its representatives against any claims or liabilities arising from damage to local roads caused by the contractor's operation.

@ **103.13 RAILROAD SAFETY TRAINING**

*The Department has a railroad safety training class. After completion of the class, the employee receives a Railway Training Certification card. This card must be carried every time the employee is on a railroad's right-of-way. Contractors must receive their railroad safety training directly from the railroad responsible for the tracks that are in conflict with our construction.*

**103.20 CONTRACT ADMINISTRATION (SEPARATE HANDOUT FOR ALL CONTRACTORS)**

This section provides instructions and guidance to contractors and Project Managers for administration of construction contracts. Instructions include information on required reports or forms, equal employment opportunity, wage reports, training program, minority recruitment, and subcontracting. Copies of all NDR forms mentioned in the *Construction Manual* are included in *Appendix 1* -- NDR forms or *Appendix 2* -- Federal Forms) and can be copied as needed. (However, use stock forms when possible to cut reproduction costs.)

**103.21 NEBRASKA & FHWA FORMS & REPORTS - PREPARED BY CONTRACTOR**

Form No.	Title	Reference Section	Office Where Forms are Available
DR-203	<del>DBE Performance Record</del>	402.27	Contracts
DR 298	Special Training Provision Monthly	102.24	Contracts
	On-Job-Training Report		DBE Office
DR 439	EEO Contractor's Self-Analysis	102.23	Contracts
			DBE Office
FHWA-1391	Annual EEO Report (July)	102.23	Contracts
			DBE Office
DR 2-A	<del>Purchasing Agent Appointment</del>	402.34	Contracts
DR 2-B	<del>Exempt Sale Certificate for Contracts</del>	402.34	Contracts
FHWA-47	Statement of Material & Labor	102.25	Construction
WH 348	Statement of Compliance	102.25	District Const. Office
Standard Form 1444	Request for Authorization, Additional Classification and Rate	102.26	Construction

@

Postings

At the preconstruction conference, the Project Manager will supply copies of the posters listed below:

a. Federal-Aid Contracts

- Federal Poster - Equal Employment Opportunity is the Law
- State Poster - Equal Opportunity Commission
- WH-1420 - Your Rights under the Family and Medical Leave Act 1993
- WH-1462 - Notice: Employee Polygraph Protection Act
- FHWA-1022 - False Statements Notice
- FHWA-1495 - Wage Rate Information



- Other training deficiencies are noted during the inspection.

It is the Construction Division's responsibility to work with the Project Manager and contractor to rectify noted discrepancies. If after a reasonable time a contractor fails to meet training requirements or ignores requests for corrective actions, the Construction Division, working through the Project Manager, may request suspension of work until corrective action(s) are implemented. Suspending work will be used as a last resort. However, the offending contractor's bidding ability on future contracts could be restricted until such time that compliance with training is demonstrated.

## 2. Wage Rates

Wage rate interviews shall ~~may~~ also be completed during the EEO inspection.

@

- *Interviews should be conducted a minimum of every six months for each contractor and subcontractor.*
- *Projects whose duration is less than six months should have one interview with each contractor and subcontractor.*

## 3. Reports

### a. "Reimbursable Trainee Training Record"

Shortly after a letting, the Contracts Office (EEO Section) will prepare and forward a letter listing projects that require a "Special Training Provision Monthly On-Job-Training Report" (Form 298) along with a supply of these forms.

Monthly, the contractor will be sending one completed Form 298 for each trainee employee until training for that employee is completed or terminated. The Project Manager will review, initial, copy, and forward the original Form 298 to the Construction Division, EEO Section. The copy will be placed and retained in the project file.

- ### b.
- Occasionally, contractors train employees on contracts that do not have a line number for trainee reimbursement. In this case, Project Managers are not responsible for monitoring that program and Form 298 is not required.

## 103.25 WAGES AND EMPLOYMENT

- ### A.
- In order to comply with the requirements of the Freedom of Information Act regarding protection of personal privacy, all requests for access to certified payroll records shall be forwarded to the Construction Division. Requests must be in writing, and if not made on behalf of an individual, the request must indicate the name of the organization making the request.

of another firm or with leased equipment should be questioned. The Construction Division shall be notified in all cases where there is a question regarding "commercially useful function".

3. Partial Subcontract of an Item

@ It is not unusual for DBE subcontractors to be involved in only part of a contract item. ~~This is to be documented on Form 203 by clearly stating in the "Description" section exactly what portion of an item is to be accomplished by the DBE and the corresponding dollar amount.~~

@ For conditions where a subcontract does not exist but a DBE firm is manufacturing, supplying, or trucking materials to the job site, ~~terms of the agreements shall be described in Form 203. This information is documented on Form 203 so the Project Manager can be assured that a prime contractor is meeting commitments previously stated on the DBE Participation Form.~~ this dollar value will not be used to determine the percent subcontracted as specified in the *Specifications*.

Inspection staff must monitor work performed and periodically inform the Project Manager as to which individuals and equipment actually worked so payrolls can be spot-checked.

C. Construction Period

@ The Project Manager and inspectors must review work subcontracted to DBE subcontractors to assure work is being performed ~~as stated on Form 203~~ and that DBEs are performing a commercially useful function. Where work is performed by any other contractor or with equipment not owned by the DBE, ~~or as listed on Form 203,~~ the inspector shall issue a noncompliance notice citing violation of *Supplemental Specifications for Specific Affirmative Action Responsibilities*. This noncompliance shall be immediately reported to the Project Manager, who will in turn notify the Construction Division.

Prime contractors will be given credit toward the DBE contract goal only when a DBE performs a commercially useful function. The requirements for a commercially useful function are outlined in the previous section "Subcontract Approval."

A DBE may lease equipment consistent with standard industry practice provided a rental agreement specifying the terms of the lease arrangement is approved prior to a DBE starting work. If equipment is of a specialized nature, the lease may include an equipment operator. No credit will be given for the cost of equipment leased or rented from the prime contractor.

DBEs shall negotiate cost, arrange for delivery, and pay for materials and supplies required for their portion of the contract work. Invoices for materials shall be invoiced to the DBE firm and not to a prime contractor.

A prime contractor may occasionally find it necessary to ensure that payments are made to suppliers for materials used by subcontractors. When such a payment arrangement is pre-approved by the Project Manager, counting the cost of materials actually incorporated into the project by a DBE subcontractor toward DBE participation will be allowable provided the DBE:

- orders and schedules the delivery of materials, and
- is fully responsible for ensuring that materials meet Specifications.

When such payments are made by the prime contractor, payments must be made by preparing jointly endorsed checks signed by the DBE and supplier.

No credit shall be allowed toward the DBE goal for cost of materials placed by a DBE subcontractor when payment is made by deducting this payment from the prime contractor's payment to the DBE.

@

Project Managers must evaluate and document performance of the DBE's activity on all projects as part of the normal project contract compliance monitoring. On-site project monitoring by field personnel shall include employee assignments, equipment used, and supervision of the work. ~~as indicated on Form 203.~~ All irregularities must be documented in the field books and immediately reported to the prime contractor, and the Construction Division.

Project Managers shall not allow a prime contractor or another contractor to perform work that has been committed to a DBE subcontractor without written approval from the Construction Division.

In situations where a DBE subcontractor cannot (or is not) performing, the prime contractor must follow all steps described in *Supplemental Specification for Specific Affirmative Action Responsibilities*. Upon receipt of a signed statement from the DBE and documentation where the prime contractor will satisfy the goal with other items or DBEs, the Project Manager may recommend to the Construction Division that the commitment be waived and the required goal adjusted. The Construction office must provide written approval of all substitutions before any changes in subcontracted work are performed.

#### D. Post Construction

Prime contractors shall submit a completed "Identification of DBE Goal Achievement" (DR Form 441) with the final project documents. The subcontractor submits DR Form 442 "Identification of Work Performed." Blank forms are provided in *Appendix 1*. These forms certify the dollar amount paid to each DBE. Project Managers must compare the dollar amounts on Forms 441 and 442 to dollar amounts committed to a DBE on "Required DBE Participation Form." The prime contractor will be assessed a penalty by change order for failure to satisfy the DBE commitments. This penalty may be reduced when conditions described in *Supplemental Specification for Affirmative Action Responsibilities* are satisfied. Project Managers must include a written

explanation describing situations, background, and findings which resulted in reductions or adjustments.

Unique problems have been noted with the goals and variables of the DBE program. Documentation of any activity related to the program is important and must not be overlooked. Record all telephone or personal contacts noting time, place, and details.

@ *The DR Form 440 Contractor EEO Compliance Record has been eliminated. These records are no longer to be maintained.*

### **103.28 LEASE OF PROPERTY BEYOND THE HIGHWAY RIGHT-OF-WAY**

The NDR has found that it is more cost effective and quicker to have the contractor make most land use agreements for areas outside the highway right-of-way. This means borrow sites, plant sites, storage areas, parking lots, and so forth are the contractor's responsibility to lease.

### **103.29 CONTRACTOR'S USE OF HIGHWAY RIGHT-OF-WAY**

Occasionally a contractor requests permission to establish a plant site or a material stockpile on highway right-of-way. In reviewing these requests, the District Engineer must consider the impact of vehicles (trucks or equipment) entering and leaving these sites on public traffic. In situations where these vehicles must enter an open ramp or lane at a point where access is not allowed to the general public, the request shall normally be denied. On two-lane roads if an access permit can be obtained and public convenience and safety is not adversely affected, the request may be approved. On closed sections of the highway, right-of-way may be used as long as trucks can enter and leave the closed road safely.

Many times a contractor will have to exit a controlled-access facility to deliver materials such as mulch, subdrain, guardrail, etc. These stockpiles may be allowed as long as the material is to be used in the general vicinity where stockpiled and is stored beyond the "clear zone".

NOTE: In these situations, the contractor will be responsible to initiate and provide a storm water permit for their operations in that area.

### **103.30 "CONTRACT QUANTITIES"**

The Project Manager and the contractor may agree to a final payment for an item based on contract quantities, i.e., plan quantity. The Project Manager shall verify that the plan quantities are reasonably accurate. If the contractor concurs with the final quantities as shown on the PM Final Estimate, the Project Manager will forward this concurrence to the Construction Division with a copy to the contractor for information.

Final review corrections should be limited to errors of \$150.00 or more per pay item. Do not waste time and money making small corrections.

**103.31 CONTRACTOR'S SALES TAX EXEMPTION**

When a NDR contract is awarded, the Contracts Section of the Construction Division will issue the prime contractor a "Purchasing Agent Appointment" (DR Form 2-A) and an "Exempt Sale Certificate for Contracts" (DR Form 2-B). These forms allow the contractor to purchase materials that are to be incorporated into a highway project without paying any sales tax. The prime contractor is allowed to make copies of both forms and provide them to the project subcontractors for their use. ~~Generally, the "Purchasing Agent Appointment" must be extended each six months.~~ The prime contractor must contact the Contracts Section [(402) 479-4851] to obtain an extension. The Contracts Section completes the extension by issuing a new "Purchasing Agent Appointment" (DR Form 2-A).

@

The following table shows the Department's approval limits:

<b>APPROVAL LIMITS</b>	
Department Director	<del>\$100,000.00</del> and above <i>\$250,000.00</i>
Deputy Director	<del>\$50,000.00 to \$100,000.00</del> <i>\$100,000.00 to \$250,000.00</i>
Construction Engineer	<del>\$10,000.00 to \$50,000.00</del> <i>\$50,000.00 to \$100,000.00</i>
District Engineer & DCE	\$0 to \$150,000.00

@

### **Preparation of Change Order**

The following instructions are applicable in the preparation of a Change Order-Supplemental Agreement:

- Create a brief description of the work not in the contract.
- Show reasons for the change; or, if the document is a combination change order-supplemental agreement, show purpose of the agreement. When the work to be performed is not covered in the specifications, the name of the items shall be worded to define the work to be performed. References should be made to similar items in the specifications or plans and the method of measurement and basis of payment definitely established.
- Show the basis of the unit prices established, such as comparison with unit prices for similar contract items or the previous year's average contract unit prices.
- Include statement as to the determination of a change in the contract time allowance.
- Show the name of the FHWA engineer and date of discussion with him/her when the Change Order is for more than \$10,000.00 and the federal-aid contract is for more than \$1,000,000 and on the Interstate.
- Enter estimated increased and decreased changes in quantities of items of work. Use standard item numbers and standard specification/contract wording, when applicable, for the new item description you define.

All Change Orders (CO) and Change Order-Supplemental Agreements (CO/SA) shall address the subject of additional working days or calendar days, if any, to be added to the contract time allowance.

The original working day or calendar day allowance is calculated by assigning some average rates of progress to the various items of work and then making some assumptions as to which items might tend to overlap during the actual performance of

make certain that the contractor has complied with *SSHC Subsection 105.12* regarding the contractor's use of land obtained by the Department.

After the work has been completed, the District Engineer shall within one week advise the contractor in writing that the work is tentatively accepted by the Department. **The Project Manager shall include in the acceptance letter a list of documents that are missing.**

In the event the Federal Government is participating in the work, the District Engineer shall notify the Division Administrator of the Federal Highway Administration immediately upon completion of the total contract or direct labor project agreement items on any project. This report shall give the actual date that all contract work was completed. If any direct labor work, such as a reflectorized railroad crossing signs, etc., which are a part of the detail estimate, are constructed later, the date of their completion becomes the completion date for the project.

**Interest Payments on Delayed Estimates** - State law provides that, "if the contractor has furnished the Department all required records and reports, the Department shall pay the contractor interest on the amount retained and on final payment due the contractor beginning the sixty first day after the work under the contract has been completed, as evidenced by the completion date established in the department's letter of tentative acceptance, and running until the date when payment is tendered to the contractor.

*The contractor is allowed fourteen calendar days from the date of notice as evidenced by the date of the letter of notification to:*

@

- (1) *Reply to the project manager's written notification of optioned pit material quantities and costs involved in a project (such reply shall be directed to the Department's Right-of-Way Division).*
- (2) *Provide signed records or documents, such as Change Order – Supplemental Agreements, requested in writing by the Department.*
- (3) *Provide all required records and reports, such as payrolls, material certifications, etc., requested in writing by the Department.*

*In the event the time interval stated above is exceeded, deductions to the interest time period will be made for the actual number of days to complete the action which occur beyond the original sixty calendar days.*

It is essential that the acceptance letter include the correct completion date which shall be in agreement with the completion date as shown in the Project Manager's weekly working day and progress reports. This date will be the last day on which any work is performed on the project, and may be several days after the last working day charged. This condition will occur when minor finishing or cleanup work is required prior to tentative acceptance.

In order to eliminate or minimize interest payments and provide adequate time for processing through the various NDR Headquarters, it is essential that the final records be completed and reviewed in the District Office as soon as possible after the actual completion date. This will require that the final measurements and computations be completed to the greatest extent possible during the time that construction is in progress and will require the taking of final cross sections for grading work (only when plan quantities are disputed) as early as possible. In some Districts, the volume of grading work will undoubtedly require the organization of "floating" parties to take final cross sections, which will require adequate District planning in advance of the need for such parties.

@ **106.08 FINAL RECORDS**

**Introduction** - The Project Manager shall prepare and submit, at the earliest possible date, all necessary records to expedite payment to the landowners along the project for right-of-way, channel changes, borrow and local pit materials, as provided in the various contracts and options as applicable to the project. Prompt payment to landowners will create good will and help in future right-of-way negotiations. DR Form 232, "Final Status Material and Site Releases" is to be prepared and submitted with the final records for each contract.

**Right-of-Way** - No measurements or computations need to be submitted for right-of-way as payment will normally be made for right-of-way prior to the actual construction, in accordance with the terms of the right-of-way contract. Any requirement for additional right-of-way shall be submitted to the Right of Way Division, through the District Office, for their further handling.

**Crop Damage** - The acquisition of right-of-way and subsequent construction often results in crop damage claims being made by the landowner. In order that information is available to settle these claims, the following should be recorded for all growing crops within the right-of-way, borrow, local pit and channel change areas.

1. A sketch showing the boundaries of each tract within station locations, angles, and distances as necessary to locate the tract accurately with reference to project centerline and to compute the area. The tract should be identified by the owner's name and tenant (if any).
2. If the tract is subdivided with more than one type of crop, show the subdivision of tract into fields as necessary to locate the limits of each crop. Information shown should be similar to that required for the tract. Indicate the type of crop growing in each tract or subdivision.
3. Show date of measurement and the name of the person making the measurement.
4. As construction progresses, record for each tract whether the crops are harvested by their owners or are destroyed by the contractor's operations. If harvested, the date of harvest should be recorded or if this date is not known, the date that the contractor began work in the area and a notation indicating that harvesting was complete should be recorded. If the crop in an area is only partially destroyed, the damage should be noted or sketched in a manner such that the area of damage can be determined.
5. The right-of-way contracts and condemnation descriptions should be reviewed carefully with respect to the provisions pertaining to crop damage. Crops planted after contract has been signed will not be eligible for reimbursement.
6. Crop damage for each tract is to be reported by letter to the Right of Way Division with a copy to the District Engineer as soon as the disposition of the growing crops on that tract is complete. The report should contain the information listed above along with computation of the area in acres, and the legal description of the property (section or part, township and range).
7. A DR Form 44 must be submitted with the final records for each project included in a contract. See *Appendix 1* for examples of this form.
8. On projects in which the Federal government participates in the cost of the work, each project is subdivided to conform with accounting practices established by the Federal Highway Administration. These subdivisions are shown in the "detail estimate", copies which are forwarded to the Project Manager by the Contracts



The schedule will be revised periodically. Any questions or comments should be referred to the Property Management Section, (402) 479-4770.

***Conversion of Existing Direct Measurement Earthwork Pay Items to Established Quantity Pay Items***

@ *Certain earthwork items may be converted from being direct-measured for final payment to being paid as established quantities. This policy is to expedite the release of final payment to the contractor, reduce possible interest payments to the contractor, and relieve a portion of the workload performed by field personnel.*

*The following items of work will be eligible for conversion:*

1. *Excavation*
2. *Excavation, Borrow*
3. *Other earthwork-related items when approved by the Construction Engineer*

*Direct-measurement items may be converted to established quantities when the following requirements are met:*

1. *The project has been staked and built according to plan, or the plan quantity has been adjusted to account for field changes.*
2. *The plan quantity has been adjusted for any obvious errors, and the contractor has been notified of the adjustment.*
3. *The project manager has made written notification to the contractor of the proposed change in the method of measurement, and the contractor has agreed to the proposal in writing.*
4. *A Change Order/Supplemental Agreement has been created and signed by all appropriate parties to document the change in the method of measurement.*

## Clearance Letter

The Project Manager shall submit a letter to the Construction Division (with copies to Motor Carrier Permits & Facilities Maintenance) indicating clearance on bridges, sign trusses, and other structures that create a clearance limit.

### 106.11 OVERRUNS AND UNDERRUNS LETTER

@ The final estimate is to be accompanied by an explanatory letter which will explain in detail the overrun or underrun of selected items included in the contract. See the mainframe LVM program, COVR for list of selected items. *The COVR program lists all contract items with changes large enough to warrant an explanation in the same order as in the contract, which exceeds the original dollar value by 5% and/or \$1,000.00.* A paragraph shall be devoted to each such item and shall have a distinct heading showing the item number, the name of the item, the total quantity of the item included in the contract and the quantity of the overrun or underrun. If there is no change in any of the quantities, a letter should still be submitted stating this fact.

Items not included in the contract shall be listed and explained under the heading of "Contingencies".

Make a general statement at the end of the letter explaining that the quantities of the contract items not listed either did not change or the changes were relatively minor (generated automatically by "COVR" program). It is possible that several large changes during the construction of a certain item may compensate each other and result in a relatively small variation from the contract quantity. Document these and any other unusual circumstances in the COVR program.

When the contract includes more than one project, a separate letter of explanation is required for each project.

On line item explanations - When the total of an itemized quantity does not equal the difference between the detailed estimate quantity and the final estimate quantity, an additional statement must be added such as "and other minor changes or field adjustments account for the increase or decrease".

Explanations of overruns and underruns should be specific. Statements such as "Preliminary estimate too high" or "Used all needed for project" are not satisfactory. The explanation should read "Preliminary estimate is too high because.....".

The Project Manager must sign and date the letter of overruns and underruns.

See Final Review Process Manual for examples of the letter.

### 106.12 CONTRACTOR EVALUATIONS

@ The Contractor Evaluation is to be completed on every contract and subcontract *except "trucking" subcontracts. SiteManager on CICS-1 identify if a subcontract is for "trucking". (Trucking subcontractors may receive an optional evaluation at the PM's discretion.* An evaluation is also to be completed on all bridge painting projects regardless of the size of the contract. Project Managers shall prepare and sign one copy of the form, include any remarks deemed pertinent, and forward one copy to the contractor and the original to the District. The District Engineer may add comments, sign, and forward to the

Contractor Report are sorted chronologically by completion date. Since the rating on a contractor's most recent work has a significant impact on his/her bidding qualifications, we want it to appear as the last entry on the report (easy to find).

For projects on which the subcontractor evaluations have not been submitted as work was completed, please enter the date the subcontractor completed work --- not the prime contractor's completion date. An entry which is a good guess is better than one which is knowingly entered in error. Evaluations are intended to affect a contractor's rating for a period of three years; and, good or bad, we want the evaluation to drop off at the appropriate time.

#### "Section 3 - Evaluations"

The ratings supplied in the nine individual categories should be made to reflect as accurately as possible the contractor's performance. The ratings remain very subjective; and, consequently, rely on the rater's fairness and good judgement.

The rating of a subcontractor in any category and the impact of that subcontractor's work on the project should be considered in determining the prime contractor's rating for the same category.

The Project Manager should keep the evaluation process in mind during the entire life of the project and make diary entries to document incidents which are particularly significant -- - enter good or bad. This documentation will help to refresh the memory on projects of long duration and can be invaluable in the event the rating results in the imposition of some type of sanctions on the contractor.

#### **106.13 LETTER OF TRANSMITTAL**

The Project Manager shall complete a letter of transmittal with project documents when they are forwarded to the District Reviewer. The District Reviewer will also create a letter of transmittal when he/she forwards the records to the Construction Division. The transmittal letter shall include an itemized list of all field notebooks, cross sections, computation sheets, forms, letters, statements, temperature charts, etc., which are being transmitted, so that the shipment can be checked to determine whether it is complete when received. When overhaul or additional haul computations were made in the Lincoln Office, attention should be directed to that fact. If there is any question regarding the accuracy of any of the computations, or there is any item which should be given special attention in the District Office, the items in question should be explained in the letter of transmittal. If the project was completed within the working day time allowance, a working day resume is not required. The transmittal letter should contain a statement indicating whether or not the work was completed within the contract time allowance and/or any internal time limits. A copy of the Project Manager's transmittal letter shall accompany the project records and final estimate when they are forwarded to the Lincoln Office.

@ *When submitting final records, please label all computation and summary sheets with the item numbers for which documentation is being provided.*

#### **106.14 FINALING PROCEDURES**

See Construction Division's Final Review Process Manual for detailed steps to finalize a project.

## 106.18 CONSULTANT INSPECTION

In regard to projects utilizing consultant inspection services, some misunderstandings have arisen when our acceptance date preceded a date when the county board “accepted” the project.

Project Development has asked that consultants utilized for engineering and inspection services be given written notice regarding project completion dates. The consultant agreements usually specify the time allowed for the preparation and submittal of As-Built Plans and other final records, and the consultants need to be told when the clock has started. It is my understanding that the consultant agreements state “*The State will provide written notification of construction acceptance to the Consultant.*” At least one consultant has reported he does not received the required notice.

Feel free to be somewhat flexible in “starting the clock”, but do put it in writing --- and **send a copy of the letter to Lee Pavel in Project Development** so he may begin his end-of-project paperwork too. The consultant services agreements and payments are audited by the Department, and it is important to have the notification documented.

### ***Protest of Final Quantities of Earthwork Items***

@ *If the contractor wants to protest any earthwork item, the contractor must notify the NDOR, in writing, of the disputed quantity, including the approximate quantity that the contractor feels is in error and the basis for the dispute.*

*The NDOR will review the appropriate data and determine if an error exists and notify the contractor of the decision.*

*Should the contractor dispute the NDOR decision, the contractor will be allowed to disprove the disputed final earthwork quantity provided the following requirements are met:*

1. *The work is done under the supervision of and the report is certified and stamped by a registered professional engineer licensed in the State of Nebraska.*
2. *The contractor furnishes the NDOR Construction Engineer with a cost estimate from the consultant for approval prior to commencement of the work.*
3. *The contractor furnishes the NDOR Construction Engineer with a copy of the contract with the consultant engaged to perform the work with a detailed description of the procedures and technology to be used in calculating the quantities prior to commencement of the work. the procedures and technology must be compatible with NDOR procedures and technology.*
4. *The report provided by the contractor to the NDOR Construction Engineer must show all calculations used to determine the quantity, list all data used in the review and its origin, identify the technology used and identify any differences between the contractor calculations and NDOR calculations.*

5. *If, after reviewing the report, the NDOR agrees that the final pay quantity or the aggregate correction of all items directly related (i.e.: Excavation and Excavation, Borrow) are in error by more than five percent (5%), the NDOR will compensate the contractor for the quantity in excess of the final pay quantity shown in the final records and for the contractor-incurred expenses to perform the post-construction calculations previously approved by the NDOR Construction Engineer.*

*Payment will not be made for contractor-incurred expenses to perform the post-construction calculations if the contractor fails to prove that the NDOR final pay quantity is in error by more than five percent (5%).*

*If the contractor's report indicates that an overpayment of more than five percent (5%) has occurred, the NDOR will pay for the contractor-incurred expenses to perform the post-construction calculations previously approved by the NDOR Construction Engineer and will make payment on the reduced quantity.*

6. *The issues of waste, shrinkage, compaction and settlement are not eligible for additional payment under this policy, and no allowance will be made for them.*

*Upon request and at no cost, the NDOR will furnish the contractor with the following information:*

1. *Preliminary Cross-Sections*
2. *Slope Stake Data*
3. *Blue Top Data*
4. *Design Cross-Sections*
5. *Current Revisions*
6. *Standard Plans*
7. *Design Calculations*
8. *Current Field Changes*
9. *Final Cross-Sections*

*The contractor's failure to fulfill any or all of the requirements stated above will be cause to deny the contractor's claim for additional compensation.*

**CHAPTER NOTES:**

**304.00 SUBGRADE STABILIZATION (SSHC Section 303)**

**304.01 DESCRIPTION**

The principal function of subgrade stabilization is to provide a stable grade for subsequent construction.

**304.02 MATERIAL REQUIREMENTS**

See the Materials and Tests Sampling Guide for sampling and testing requirements.

**Obtaining Materials From Local Pits**

In general, the contractor must obtain all off site pits and close them with the landowner. The Department no longer tracks site releases for contractor provided pits.

**304.03 EQUIPMENT**

The inspector should carefully check the contractor's equipment and calibrations. Pay quantities and other important measurements may be based on some of the equipment and we need to make certain that they conform to the requirements of the Specifications and the special provisions.

**304.04 CONSTRUCTION METHODS**

This item consists of the stabilization of non-cohesive sand by the addition of a natural soil binder material. In order to insure satisfactory performance of the overlying pavement, especially if it is of the flexible type, the following points should be kept in mind:

1. Silt clay soils exhibit poorer support for pavement if they exist as thin layers over pervious sands than if they comprise the full depth of the subgrade. For this reason, the placement of a thin soil binder layer over the sand should be prohibited.
2. The minimum amount of soil binder required to support construction operations should be used. An excessive amount of binder causes the mixture layer to act as a silt-clay layer as in 1 above.
3. Thorough mixing of sand and soil binder is conducive to good performance.

@ 4. *A stabilized subgrade will allow paving equipment to travel over sandy areas.*

### Special Concerns

When temporary traffic signals are involved, the contractor shall arrange for emergency maintenance services. No payment will be made to contractor.

On urban projects, DCE will need to coordinate with the city to determine who is responsible for access, signing, and safety features.

#### 404.09 **FLAGGERS & PILOT CARS (SSHC Section 422)**

*The Department, in conjunction with the AGC, has made the Flagger Certificate quiz, the Flagger Training video, and a Flagger Training audio cassette available in Spanish.*

@ *The availability of this material in Spanish in no way is meant to void the specification that requires that flaggers read and speak English clearly. However, in recent years the number of Hispanic workers on our construction projects has increased. The intent is to provide better education to those whose native language is Spanish, realizing that while they may be able to speak English clearly they may have difficulty learning and taking a test in English. You could relate it to learning metrics. While we know and talk metric, few of us really think in metric.*

*The flagger on a construction project is the first line player in communicating with the driving public. It is imperative that the flagger be able to speak English clearly with the drivers in a work zone. The contractor is responsible for insuring that anyone performing flagging can meet these requirements.*

#### **Flagger Bid Item**

@ *If the contractor's flagging crew (irregardless of crew size) works four hours or less, then ½ flagger day is charged. If the crew works more than four hours, then one flagger day is charged.*

~~Many project plans include a bid item for flaggers. This "predetermined price" item is based on Davis-Bacon wage rates for the flagger labor classification. Questions have arisen regarding measurement of the flagger item when the contractor is working split shift or two shift operations. According to SSHC Section 422, a flagger must work four hours or more per day to be counted as one flagger day. The following guidelines should be used to determine appropriate number of flagger days.~~

- ~~• If contractor has entire crew working long extended days, then regardless of the number of hours worked above four hours, one flagger day will be counted for each individual flagger operation. This holds true if contractor takes an extended lunch break or other breaks due to project traffic control plan requirements, **if the same work crew** returns to work after the break.~~
- ~~• If during a single day, distinctly separate shifts with different work crews are worked, then for the number of hours worked above four hours for each shift, one flagger day will be counted for each individual flagger operation per shift. For this option to qualify, **entire contractor work force must change**. This should not allow a contractor to collect multiple flagger days by rotating flagger personnel only.~~

#### **Slow/Slow Paddles**

The Flagger Handbook indicates that when a flagger is used near the lane-line to warn public traffic of workers and equipment close to the open lane, then these flaggers are only allowed to use a "slow/slow" paddle. This paddle shall be 0.6 m (24 inches) diamond shaped with the word "slow" in black letters on orange background on both sign faces. The standard stop/slow paddle shall never be used on a multi-lane highway, since through traffic should never be forced to stop on these roadways.



The slow/slow paddle shall not be used on two-lane primary highways, since the purpose of the stop/slow paddle on these roadways is to actually stop traffic and then allow them to proceed through the traffic control zone under pilot car or flagger control.

@ **Method of Measurement**

If an item for flaggers and pilot cars is included in the bid proposal, days are estimated to determine the low bidder. These bid items often overrun due to contractors using multiple work crews at different locations within the same project.

The inspector will count the number of days each flagger (or pilot car) was used. Every flagger and pilot car used and approved by the PM as part of a preplanned work operation is to be paid if their usage is required as a part of required traffic control. Flaggers used solely as a benefit to contractor to help control their own equipment are not to be counted for payment.

**404.10 INTERSTATE TRAFFIC CONTROL REQUIREMENTS**

Median Crossings

The contractor is prohibited from using any established or other type median crossover on most four-lane divided highway projects unless a crossover is required and drawn in the Plans.

**Traffic Control Removal for Head-to-Head Projects**

The procedure to remove traffic control devices from head-to-head sections of interstate repair projects has been accomplished differently across the state. To achieve uniform removal practices across the state, the following steps will be used to remove traffic control devices from head-to-head projects:

- Move diverted traffic stream back to its normal side of median.
- Place plastic drums in closed (passing) lane at intervals as prescribed in *Manual on Uniform Traffic Control Devices*.
- Remove all "Two Way Traffic" (W6-3) signs, leaving "Do Not Pass" (R4-1) signs in place.
- Remove double yellow lines with simultaneous removal of tubular markers, "Do Not Pass" signs, and plastic drums. At the same time yellow lines are removed, new white lane lines shall be placed. If lane line painting cannot be accomplished the same day as the double yellow lines are removed, plastic drums shall remain in place effectively closing the passing lane.
- Remove impact attenuator and all temporary barrier rail at upstream end.
- Remove any advance construction work zone signing in the direction towards oncoming traffic.

The entire removal operation shall proceed upstream towards traffic. This will ensure that motorists will have two clear open lanes once they pass traffic control removal operations. Tubular markers shall not be removed in any area until the double yellow lines are removed, unless they are replaced with vertical panels or Type II barricades.

## 502.40 ASPHALT PAVEMENT CONSTRUCTION METHODS

### 502.40.1 UNSTABLE SUBGRADES AND SUBBASES

See *SSHC Sections 302, 303, and 305* for subgrade requirements.

Whenever trucks or other paving equipment cause rutting of the subbase or subgrade in asphalt placement areas, inspectors shall immediately stop construction. Construction shall not be allowed to resume until distorted subgrade or subbase is repaired (*SSHC Subsections 105.03 and 105.10*).

#### Locating Unstable Areas

@ Contractors and inspectors should locate by proof rolling, any questionable unstable areas in advance to avoid distortion under equipment. Wet, unstable areas ~~can~~ *must* be dried out *or replaced* before starting placement of asphalt to avoid unanticipated and costly work shutdowns.

@ Locating wet or soft areas in advance can be accomplished by testing finished subgrade or subbase with a loaded truck. When the proof truck causes subgrade distortions, the subbase and subgrade ~~can~~ *must* be dried out and reworked.

Construction of asphalt pavement should not proceed unless testing gives a reasonable indication that distortions will not occur during construction of overlying pavement.

#### Determining Cause

During spring and early summer, unstable subgrades caused by high moisture contents are encountered statewide. This condition is usually seasonal and tends to improve as warmer, dryer summer weather stabilizes subgrade. Additional pavement thickness is not justified to bridge over these particular soft subgrades because of their seasonal nature.

When evaluating individual cases of instability, experienced judgment is advisable because of the similarity in outward appearances between moisture in subgrade due to seasonal conditions and more serious causes such as frost boil, unsuitable material, etc.

If excess moisture is encountered, dry subgrade and recompact.

#### Drying and Recomaction

@ This treatment may be paid for as extra work provided the Project Manager authorizes it, and the work is closely monitored by the inspector *and the contractor did not cause the wet condition*.

*SSHC Subsection 205.03* or special provisions require the contractor to disc or take other action to remove moisture and then recompact the soil at their expense. For a natural subgrade, contractors are required, if necessary, to repair distorted areas by scarifying to a depth up to 150 mm (6 inches), aerating, and recompacting at their

expense. Overdepth aeration and recompaction below the top 150 mm (6 inches) shall be paid for as extra work (*SSHC Subsections 302.03 and 503.04*).

When repair, drying, and recompaction are required to correct damage from contractor's operation, all necessary repair will normally be done at the contractor's expense. However, if the Project Manager determines that additional depth of aeration and recompaction are needed, that should be paid as extra work (*SSHC Subsection 302.03*).

### **Special Treatments**

When unusual problems are encountered with unstable subgrades or subbases, the District Engineer should contact Materials & Tests for assistance.

## **502.40.2 GRADELINE STRINGS AND EDGE ALIGNMENT**

### **@ New Construction**

The inspector should make frequent measurements to insure the guideline string has been correctly set and maintained. ~~String~~ Support arms used to secure the guideline string shall be at intervals close enough to minimize chords on curves and other irregularities. Make the curve look like a curve.

Guideline strings placed on two-lane asphalt pavement should be located by measuring from redhead nails placed on centerline. Placement of a lower asphalt layer will cover redheads. For succeeding lifts, guideline string should be located by measuring from exposed nails used to hold string for each previous lift.

### **@ Resurfacing**

@ When resurfacing two-lane PCC pavement, contractors may locate guideline strings on shoulders along outer edges. To insure that parallel alignment is used for an adjacent lane, the ~~guideline~~ *gradeline* string for that lane shall be located by measuring across pavement from ~~string support arms used to secure~~ the first string.

True edge alignment controls the correct lap at each longitudinal joint. If insufficient lap, the joint will lack density resulting in raveling and joint deterioration. Excessive lap produces an objectionable wide scab of mixture on the surface next to the centerline joint, resulting in an unacceptable appearance.

An intended lap of 25 mm (1 inch) with a variance of 12.5 mm (½ inch) will normally be the optimum overlap for longitudinal joint construction. To maintain these close variances, adjacent lane must be constructed with true edge alignment.

The finishing machine operator shall follow the guideline string exactly. If the machine goes off line for any reason, it shall be adjusted back onto the line immediately. It is incorrect to smooth out the edge alignment by coming back onto the line gradually. This results in long stretches where incorrect lap at longitudinal joint will occur. When batch trucks bump finishing machines off line on curves, movement is usually down the slope of the curve. If the machine is brought back on line gradually, an objectionable, long, straight chord will result in what is supposed to be curved edge alignment.

Irregular edge alignment due to any cause, including adjustments of finishing machine, shall be corrected at once by hand tools. When corrections in edge alignment are

unable to be made promptly after they occur, the inspector shall require the finishing machine to be stopped until workers catch up with making corrections.

- @ When constructing handworked areas such as driveway ~~run-outs~~ *returns* and bridge approach tapers, edge alignment may become irregular during rolling because small, high, and low spots in handworked surface tend to extend in width unevenly. Edge alignment of handworked areas can be made true by first rolling the surface with a steel roller, then immediately trimming the edge with hand tools while the mixture is still hot and workable.

### 502.40.3 LONGITUDINAL JOINTS

To obtain adequate compaction at longitudinal joints, the contractor shall place sufficient thickness of mix to compensate for 20 to 25 percent reduction in thickness that normally occurs from rolling. If thickness is insufficient prior to rolling, joint will usually be smooth in appearance but lack density because of inadequate compaction.

#### **Make sure density is checked along the joints**

The vertical face of exposed, longitudinal joints must be tacked before the adjacent lane is placed. This treatment is very important to insure a seal at the joint. No tack coat shall be sprayed on the surface of lane being matched. Shields on distributor spray bar will help protect adjacent lanes (*SSHC Subsection 503.04*).

If overlap is maintained at approximately 25 mm (1 inch) and thickness of joint is correct, brooming or raking may not be necessary to obtain a good joint. However, occasional corrections with hand tools may be necessary. When hand work is completed, excess material should be wasted as opposed to scattered on lane being constructed.

### @ 502.40.4 ~~PRIME AND TACK COATS~~ USING EMULSIONS

#### **For Dilution**

SS-1, SS-1H, CSS-1, and CSS-1H grades are specified. Dilution of emulsion is required if nonuniform tack applications are experienced. Dilute at 1:1 ratio, i.e., 1 L emulsion to 1 L water.

#### **Application Rate for Diluted Emulsion**

- @ For diluted material, double the rates of undiluted material application. Example: 0.14 to 0.28 L/m<sup>2</sup> undiluted increased to ~~0.272~~ .28 to ~~0.454~~ .56 L/m<sup>2</sup> dilute emulsion.

### Sample for Compliance

Sample emulsion at spray bar of distributor with bar valve in a circulating position, prior to dilution.

### Measurement for Pay

Net liters of diluted emulsion.

Keep in mind, diluted emulsion as supplied normally contains 60% asphalt residue, therefore, a 1:1 field diluted emulsion will contain the minimum of 30% residue (*SSHC Subsection 504.03*).

### Settlement of Diluted Emulsions

Varying residue rates of diluted emulsion may be related to blending of original emulsion or settlement while in storage. To minimize this problem, the following steps are recommended:

- Contractor emulsion delivered to storage should be gently circulated prior to pumping into distributor truck.
- If contractor obtains emulsion directly from terminal, the emulsion should be gently circulated prior to use each day.

Material in a storage tank can be circulated with a large diameter, slow turning propeller, or by pumping from top to bottom. Only a small amount of agitation is necessary. **Forced air should not be used for agitation since it may cause the emulsion to break.**

### @ 502.40.5 DENSITY CONTROLS FOR ASPHALT ASPHALTIC CONCRETE CONSTRUCTION (*SSHC Subsection 503.06*)

@ Specifications for asphalt *asphaltic construction* require each layer to be compacted to a density not less than a given percentage of the Rice voidless density.

@ Density of pavement is determined from cores cut by contractor or by nuclear density gauges, normally on the working day following construction. *The method of mix density determinations will be agreed upon before construction begins.*

@ Four hot box samples per day will be obtained *from the roadway surface by the contractor* and transported to the field lab for testing. The lab ~~should~~ *will* determine the voidless density.

An average of the voidless densities for a day's production will be used to determine the degree of field density.

Five samples shall be cut from each 2500 Mg (2750 tons) or use Nuclear Density Gauge to determine density.

The Specifications also describe a procedure for field density evaluation together with a schedule for payment adjustments when noncompliance occurs. Project inspection personnel shall observe the following:

- @ • The contractor is required to take a prescribed number of samples at locations selected and marked out by the project inspector. The project inspector or ~~monitor~~ will witness the core sampling. A circle approximately 400 mm (16 inches) in diameter is adequate for identification of sampling location. The core should be taken from within the area identified. It is not appropriate for the contractor to use a nuclear device to "hunt" for a particular spot to sample; coring locations are no longer random when a nuclear device is used in this fashion.
- @ • Sample locations are identified in the random sampling schedule which ~~shall will~~ be provided by *Materials & Tests*. A core will not be taken less than 300 mm (12 inches) from the edge of a given pass of the finishing machine. Procedure for identifying random locations should provide for the potential to obtain a core sample at any distance 300 mm (12 inches) or greater from the edge.
- @ • If the layer being sampled adheres to a lower layer, it may be necessary to sample through two or more layers or full depth. The contractor will need to remove the extra depth by sawing the sample with a masonry saw. It may be necessary to cool the sample by refrigeration or ice to prevent damage during sawing. It is important that core *drill* bits be kept sharp.
- @ • Each sample shall be inspected carefully by the contractor and inspector prior to testing. Be sure each core sample is representative of the density of the mixture placed, i.e., and not damaged. If damage is noticeable, ~~or if sample is thinner or thicker than Specifications allow~~, discard without testing and take another to replace it.
- @ • If tests indicate that density is less than the specified percentage, the sample shall be retested to insure accuracy. The contractor can request another random sample be taken. (See *SSHC Subsection 1024.02*.)
- @ • Tests on density samples give lower results if samples are damaged during handling. Contractors and project inspectors are advised to use extreme care when taking, transporting, and preparing cores for testing.
- @ • Samples should be transported on hard flat surfaces to avoid loss of density by distortion. If necessary, ~~to store samples, storage~~ should be *stored* in a cool place and on a hard flat surface.
- @ • Specifications also require *the* contractor to take density samples as promptly as practical as prescribed by NDR T 168. Samples should be taken no later than the working day following ~~construction~~ *placement*. If the contractor is unable to comply with this timing, the project inspector shall stop construction until the contractor is able to do so.
- @ • NDR personnel shall be responsible for ~~the running of the~~ *performing* density tests as prescribed by NDR T 166 using the contractor provided samples.

- Any failures should be reported to the Project Manager and to the contractor on the day tests are performed.
- When rerolling is performed, insure the area that is rerolled is the complete area of low density, not just the area of the sample.

#### **Procedures for Construction of Test Strips (SSHC Subsection 503.04)**

@ SSHC Subsection 503.04 requires the contractor to construct a control (test) strip for all mixture types ~~(except 17 types)~~. Test strips are used to evaluate properties of asphalt mixture *and identify an*. ~~An effective roller pattern. may also be identified.~~

Proper construction and documentation of the test strip is the responsibility of the contractor and shall be provided by the contractor to the NDR inspector.

Document the procedure that was followed to construct the test strip.

#### **Resolving Density - Void Conflicts**

@ The project inspector should be aware that the field laboratory and compacted voids are to be tightly controlled. This may require more compactive effort and even higher average density for compliance. Become familiar with other controls by reading *the Materials Sampling Guide* and asking questions of Materials & Tests personnel.

For the case where specified density is met, but field laboratory voids are outside designated limits for two moving average points, the production will cease. The Project Manager may allow production to start following agreement on corrective action to be taken. The contractor will select the combination of rollers to be used and preliminary rolling pattern. Nuclear gauge readings would normally be taken after each pass or series of passes.

@ The inspector shall only observe and document this process. Documentation of type and amount of compactive effort shall be recorded. Inspector will then select and mark out five random core sites within *the* test site. Density cores taken by contractor ~~would~~ *will* be tested and results reported as soon as possible.

Cooperation between the project inspector, Materials & Tests, and the contractor is essential to reach a timely solution. If all anticipated results are not met, further experimenting with a different combination of rollers and operation should be performed. Changes in gradation may be one of the first items looked at by Materials & Tests. Changes in asphalt cement content would be one of the last items. Relief from minimum laboratory voids specified may only be approved by Materials & Tests.

### 502.40.6 LAYING WIDTHS FOR ASPHALT

Plans for asphalt projects will show the overall dimensions of finished pavement.

When spreading layers of asphalt 38 to 50 mm (1 ½ inches to 2 inches) in thickness, a typical 7.2 m (24 foot) pavement may broaden 50 to 100 mm (2 to 4 inches) in width during rolling. Therefore, laydown width before rolling might require 75 mm (3 inches) less than final design width. An intended lap of 25 mm (1 inch) at longitudinal joint is necessary for proper joint construction. Use of a cutoff shoe when matching a longitudinal joint is not acceptable.

When using finishing machines that spread the pavement full width, the inspectors shall insure that contractors adjust the spreading width so the final dimensions conform to the dimensions specified in the project documents.

@ The finishing machine screed extensions are usually available in 150 mm (6 inches) increments. Where standard screed extensions are utilized to increase the paver width by more than 300 mm (12 inches), the paver auger ~~shall~~ *must* also be extended. Many new pavers are equipped with automatic screed extensions which can be adjusted to conform to the required width for most resurfacing situations. Some paver models have automatic auger extensions as well.

### @ 502.40.7 SPREAD PLACEMENT RATES FOR HOT MIX ASPHALT BASES, BINDER, AND SURFACE COURSES

@ *The inspector shall check contract quantities for accuracy.*

@ In general, ~~spread~~ *placement* rates for hot mix asphalt shall be determined using the contract asphalt mass. The estimated unit mass from design standards used to calculate contract quantities will provide sufficient material for construction of design thickness for most mixtures used.

If the contract quantity is not sufficient to construct the required thickness, notify the Construction Division.

@ For lower layers on resurfacing projects, automatic controls should not be adjusted repeatedly based on megagram yields taken at short intervals. Automatic controls should be allowed to correct for irregularities in underlying base without frequent adjustments. Accordingly, the ~~spread~~ *placement* rate for individual truck loads will sometimes vary substantially from contract rate because of irregularities in old base. However, over longer distances, 500 m (1650 feet) or more, taking both sides of the pavement into account, inspectors should select a general spread rate that compares as closely as possible with contract quantities.

For paved shoulders or other construction where dimensions are controlled by specified elevations, existing structures, or other unusual requirements, spread rates shall be adjusted as necessary.



### 502.40.8 COLD WEATHER ASPHALT CONSTRUCTION (*SSHC Section 501*)

*SSHC Subsection 501.01* contains limitations for placement of asphalt and liquid bitumen under cold weather conditions. These restrictions apply to pavement surface temperature and time of year, and vary according to whether layer is surface course, lower binder, or base course, and nominal lift thickness.

Cold weather construction problems may show up in the form of increased roughness on profilograph, mat raveling, low density, high voids, segregation, slippage, or failure of tack coat to break. The Project Manager and inspector should be aware of other weather related conditions which may further limit placement.

After September 15, it is appropriate to require tarping and insulation of truck bodies especially if hauls exceed 5 km (*SSHC Subsection 503.04*).

Base temperature is the single greatest factor in the rate of cool down for freshly placed asphalt mat. Consequently, base temperature has direct affect on recommended minimum laydown temperature and rolling time available to obtain specified density.

Wind velocity, air temperature, and cloud cover are additional factors that affect the cooling rate of hot mix asphalt.

For fall work, a cutback asphalt may be used at the Project Manager's option. Cold surface temperatures cause emulsions to lose tackiness and increase breakage time resulting in higher risk of mat slippage.

### 502.40.9 RUMBLE STRIPS IN ASPHALT SHOULDERS

#### @ **Construction Considerations**

~~Numerous variables associated with constructing rumble strips have contributed to moderate inconsistency in depth and tearing that occur during placement. After the first day of shoulder resurfacing, most contractors/inspectors should be able to identify adjustments needed to produce uniform indentations in fresh asphalt. Contractor may "practice" construction of rumble strips while placing lower lifts of shoulder resurfacing. This is a good idea for inexperienced project personnel or unfamiliar mixes.~~

~~Two primary problems associated with constructing rumble strips in asphalt shoulders are depth uniformity and mat tearing/cracking.~~

~~Depth uniformity is dependent upon uniformity of mat density and temperature at the time rumble strips are placed. This is simply a specified roller pattern. Normal overlap associated with compaction operations tends to produce short areas where indentations are shallow compared to the majority of the grooves. This is not objectionable as long as length is minimized and limited to 7.5 m (25 feet).~~

~~Higher mat temperatures are required to get adequate groove depth for mixes with high crushed particle contents. Rolling with the rumble strip drum roller should generally follow immediately behind the intermediate rubber tired roller.~~

@ Lower temperatures are appropriate on the outside shoulder. Temperatures ranging from 60 to 65°C (140°F to 150°F) should produce acceptable depths.

Mat tearing/cracking is also controlled by placement of rumble strips at appropriate temperatures. Rolling at high temperatures tend to induce more cracking than lower temperatures. Forward speed of roller must also be as slow as possible to help minimize tearing of hot asphalt. Some contractors are now using a steel roller with indentations on the drive drum rather than a small diameter trailer drum. This type of equipment is less sensitive to mat temperature and tends to produce more uniform indentations with less cracking and tearing. When the trailer drum system is used, a narrow temperature range may exist to achieve adequate depth without excessive tearing.

Excessive tearing can usually be partially closed by a static pass with a steel roller. Again, it is very important to make this pass while mat is warm enough to close cracks without eliminating groove depths.

Some contractors have also added supplemental mass to the rumble strip roller to assist in producing acceptable groove depth. This may be accomplished by adding water to rear drum or fastening metal mass to rear of roller.

Most contractors have added a third drum to a conventional two-axle tandem steel roller. This supplemental drum has half sections of pipe welded at 200 mm (8 inches) spacing with tapered ends to produce grooves detailed in the plans. It is mounted on rear of roller so it can be hydraulically pushed down onto fresh asphalt mat. The amount of downward force is generally limited by maintaining enough mass in the drive axle to move the roller; therefore, additional mass as noted above is usually beneficial.

A lift thickness of at least 50 mm (2 inches) is needed to produce an acceptable groove depth without weakening the bond with the lower layer. 75 mm (3 inches) should provide further protection against cracks developing through the entire lift.

@ *Rumble strips will be milled into shoulder on future projects. Department will no longer accept rolled-in rumble strips.*

#### **502.40.10 QUALITY CONTROL MONITORING**

Requirements for monitoring a contractor's quality controlled plant operation are shown in Table 502.40.1.

be corrected by hand tools. When the straightedge indicates no high or low spots, compaction should be permitted with the initial roller.

3. The third check with the straightedge is across the joint between cold pavement and hot mixture after compacted with initial roller. This third check indicates whether the correct amount of material has been placed. For instance, if freshly rolled layer is too high, it indicates too much material has been placed. If freshly rolled layer is too low, it indicates not enough hot mixture has been placed.

For that reason, high or low transverse joints are not usually corrected by additional rolling. Instead, corrections should be made by cutting or filling the rolled surface while the mixture is still warm and can be manipulated. If there are unusually high or low areas after rolling, paths must be shoveled through the pavement for finishing machine tracks. Finishing machine is then backed up to the joint and paving operation is started again.

The above procedure shall be repeated as necessary until the straightedge indicates that a good riding joint has been constructed. If repeated repaving operations cause the mixture to cool to the extent that reuse becomes impractical, it should be removed and wasted.

4. The final procedure for insuring proper construction at transverse joints is checking for true edge alignment. Edge of the freshly rolled layer should be carefully trimmed by hand tools until it matches the alignment of adjoining cold pavement.

@ **502.50.3 ASPHALT CEMENT PERFORMANCE GRADED BINDER**

@ When payment for an ~~asphalt~~ *asphaltic concrete* mixture is based on megagrams, payment will also be made for asphalt cement as a separate item. Compensation will be made for all megagrams of ~~asphalt cement~~ *binder* incorporated into the construction within Specification tolerances. (*SSHC Subsection 503.05*)

@ Megagrams of ~~asphalt cement~~ *binder* paid is not deducted from megagrams of ~~asphalt~~ *asphaltic concrete* mixture measured for payment.

@ When small quantities of ~~asphalt cement~~ *binder* are involved, the design plan may state that asphalt cement is considered subsidiary to ~~asphalt~~ *asphaltic concrete*. Check the special provisions for this reference.

@ For specific mixes used as patching materials, or in an alternate bid situation, payment may not be made for ~~asphalt cement~~ *binder*.

@ **Tank Measurement and ~~Asphalt Cement~~ Performance Graded Binder Content Determination**

At batch plants, automatic or semi-automatic printouts record the actual mass of asphalt cement in each separate batch. This quantity may be used for payment.

Volume measurements will be converted to mass by computation. The amount in storage at beginning of project will be measured or estimated by inspector and added to

@ amount measured for payment. Asphalt ~~ement~~ *binder* remaining in storage at end of project and amount otherwise not used in the work will be measured or estimated by inspector and deducted from amount measured for payment.

@ **Measuring Asphalt Cement *Binder* for Small Quantities**

@ *SSHC Section 109* provides that by mutual agreement, the method of measuring asphalt ~~ement~~ *binder* for payment may be modified when small quantities or intermittent operations are involved.

@ If a recorded mass is not available, quantity may be calculated from intended asphalt ~~ement~~ *binder* percent with asphalt plant meter results providing further verification. For small quantities on a given day, the previous day's tank stick may be used as a check.

The project inspector should document procedure selected and reasons for doing so.

**Asphalt ~~Cement~~ *Binder* Quantities and Pay Adjustments**

@ Asphalt ~~ement~~ *binder* contract quantities for a project are estimated based on a basic asphalt ~~ement~~ *binder* content identified in the contractor's mix design.

@ When noncomplying viscosity or penetration tests occur, payment for asphalt ~~ement~~ *binder* incorporated into affected asphalt mixture is subject to price adjustment as prescribed in the *SSHC Subsection 503.06*.

@ **502.50.4 TARGET VALUES FOR ASPHALT ASPHALTIC CONCRETE PRODUCED**

@ The tolerances specified for asphalt ~~ement~~ *asphaltic* concrete are provided for reasonable variances only. Whenever regular and repeated variances from target values occur, the Project Manager shall insist on quick and corrective action by contractor to secure target values, not simply within tolerance.

@ The above comments are addressed to asphalt ~~ement~~ *binder* content, aggregate tolerance and specifically to air voids and VMA values.

**502.50.5 MEASURING ASPHALT MATERIALS**

*SSHC Subsection 503.03* covers equipment and procedures for measuring the mass of the asphalt materials. When automatic or semi-automatic measurement is used, continuous direct observation of the measuring process by a scale inspector is not required. For manual measuring of loaded trucks, Project Manager may assign a scale inspector. This normally occurs only when accuracy in the measuring procedures is in question.

When witnessing is required, scale inspector should be positioned near contractor's scale operator so measuring can be closely observed. Contractor's representative shall write the scale tickets and present them individually to scale inspectors for their signatures or initials before each truck leaves the plant.

**504.00 STATE MAINTENANCE PATCHING**

@ Asphaltic Concrete for State Maintenance Patching and ~~Asphalt Cement~~ *Performance Graded Binder* for State Maintenance Patching are always nonparticipating items and should be paid for with State funds only.

The Construction Division, Final Reviewers Office, has seen estimates that were incorrectly prepared. The estimates do not split these items out from the participating items. Thus, they are not split out on the progress estimates, either.

Please check your projects to assure that these items are in a "State Funds Only" Section. If they are not, create a new section and move them using CICS3, Function 21, Subfunction 4.

Contact Highway Coordinator Finals Supervisor Bill Hitzeman, (402) 479-4456, if you have any questions.

**601.03 CONCRETE PAVEMENT REPAIR CHECKLIST**

SSHHC References:                      *Section 600 Portland Cement Concrete Pavements*  
*Section 605 Concrete Pavement Repair*  
*Section 1002 Portland Cement Concrete*  
*Section 1012 Liquid Membrane-forming Compound*  
*For Curing Concrete*  
*Section 1013 Bituminous Liquid Compound For*  
*Curing Concrete*  
*Section 1014 Joint Sealing Filler*

Inspection Crew:                      Pavement inspector  
Certified Plant Inspector

Inspection Equipment:                Slump Cone  
Air Meter (pressure)  
Cylinder Molds and Lids  
Rod  
Mallet  
Strike Off Bar  
Ruler  
3 m (10 foot) straightedge  
Subgrade Templet  
Water Bottle

- Patching Procedures:                1. Mark areas of pavement removal.
2. Preplacement check of the equipment.
3. Check subgrade.
4. Check base or foundation course.
5. Check placement of steel.
6. Check Form setting and alignment, if used.
7. Have contractor wet grade before concrete placement.
8. Test concrete for air content and make cylinders when  
the consistency of the concrete appears different and  
as a minimum according to the Sampling Guide.
9. Watch concrete placement for compliance with  
specifications.
10. Should not use water as a finishing aid ~~except~~  
@ "orchard" sprayer as noted in ~~SSHHC~~  
~~Subsection 603.03~~; an approved chemical finishing  
aid/evaporation retardants are also authorized.
11. Check tining for conformance to specification.
12. Watch curing operation for conformance to  
specifications.
13. Keep track of ambient temperature during curing  
period.

Construction Critical Area:        1. Specified mixing is required to insure uniform  
dispersion of admixtures.

ASTM and AASHTO specifications. In one instance, the certification also stated the material to be pretested. However, this has since been corrected by the manufacturer.

We want to emphasize that if hot pour joint sealer is from tested and approved stock, this material can then be used upon delivery to the project. The lot number will appear on the NDR Approved Products List for approved stock. The Materials and Tests Division should be notified as to the lot numbers and quantity delivered. If the lot number is not on the NDR Approved Products List, then the joint sealer must be tested and approved before it is used. We do not accept joint sealer by certificate of compliance or by a Project Manager's certification, unless this is the rubber modified asphalt compound consisting of an asphalt cement containing a minimum of 22 percent of new or reclaimed, synthetic or natural rubber. This material is accepted by a certificate of compliance furnished by the supplier per the Special Provisions.

The foregoing instructions concerning tested and approved stock also applies to cold poured joint sealer, preformed joint filler, and pressure relief joint filler.

#### **White Pigmented Curing Compound**

@ ~~In the case of White pigmented curing compound that are approved for use are shown on the Approved Products List. before it is used, the Materials and Tests Division should be contacted to be certain that the lot numbers supplied have been tested.~~ The Materials and Tests Division should be advised as to the quantity and lot numbers involved. Reports will then be issued to the project. Curing compound not from tested stock must be sampled and tested prior to being used. We do not accept curing compounds by certificate of compliance or Project Manager's certification.

#### **Preformed Polychloroprene Elastomeric Type (SSHC Section 1016)**

The construction procedures in *SSHC Subsection 603.03*, Paragraph 7 are quite detailed and close adherence to these instructions is important to insure the proper performance of the seals. Important points to emphasize in this type of construction follow:

1. Installation should result in less than 5 percent elongation of the performed seal.
2. Sawed joint dimensions should be of correct size - neither too large or too small.
3. Sawed joints should be inspected closely for cleanliness at the time of installation.
4. Spalls should be repaired as indicated in the specifications.
5. Certification as indicated in Specification Subsection 1016 should be in the Project Manager's files before installation.
6. Excessive adhesive has been known to accumulate on the top of the seal, preventing proper expansion of the seal.
7. Hot dry weather can produce a condition of premature set to the adhesive and this can be the cause of seal popping.
8. The seals be placed at the specified depth. If placed too high, attrition will take its toll.

Pile Driving Analyzer  
Procedures

1. Contact the Construction Division to schedule personnel and equipment.

Static Pile Load Test Procedures

1. The Department will furnish the equipment and personnel for conducting the test. The contractor shall unload, erect, dismantle and reload the testing equipment. Payment for this work shall be by the each for each test.
2. If a temporary anchor pile is required. It will be paid for as extra work.

Method of Measurement  
Procedures

1. If required bearing is obtained at minimum penetration and this is shorter than the order length, the contractor should be encouraged to continue driving until the order length has been driven. Usually he/she will want to drive this extra length to avoid payment deduction. Discontinue driving beyond minimum penetration when:
  - a. Practical refusal is reached.
  - b. Further driving may result in damage to the pile.
2. If practical refusal is reached before minimum penetration, discontinue driving and notify the District Construction Engineer or the Construction Division and do not cut off the pile without their approval.
3. No payment will be made for pile length driven beyond the order length *without PM approval*.
4. When steel "H" pile and steel pile shells are driven to the exact cut-off elevation without crimping or damage to the top of the pile, they need not be cut off. Length of pile cut-off (measured as provided in *SSHC Subsection 703.05*) shall be paid at 60% of the piles unit price.
5. It will be necessary to pay for pile cut-off only under the following conditions:
  - a. When practical refusal is reached before minimum penetration and the pile cannot be driven or jetted further.

@



Inspection Equipment:

Slump Cone  
Air Meter (pressure)  
Cylinder Molds and Lids  
Rod  
Mallet  
Strike Off Bar  
Ruler

Placement Procedures:

@

1. Preplacement check of equipment.
2. Check condition and placement of steel.
3. Check Form setting and alignment. Verify location coordinates and orientation.
4. Have contractor wet grade *and forms* before concrete placement.
5. Test concrete for air content, slump, and make cylinders when mix changes, as a minimum according to Sampling Guide.
6. Watch concrete placement for compliance with specifications. Do not allow free fall greater than 1.5 m (5 ft).
7. Do not use water as a finishing aid; use an approved chemical finishing aid/evaporation retardant.
8. Check curing operation.

Construction Critical Area:

1. Take pictures of any pavement under bridge before work begins.
2. Achievement of concrete consolidation without segregation.
3. The time between loads of concrete.
4. Trucks that segregate concrete or have cement balls must not be used.

NDR Tests:

1. NDR T 23 Making and Curing concrete test specimens.
2. NDR T 119 Slump of Portland Cement Concrete.
3. NDR T 141 Sampling of Fresh Concrete.
4. NDR T 152 Air Content of Freshly Mixed Concrete by the Pressure Method.

**701.03 CONCRETE BRIDGE FLOORS CHECKLIST**

*SSHC References:*

*Section 706 Concrete Bridge Floors*  
*Section 1002 Portland Cement Concrete*  
*Section 1010 White Opaque Polyethylene Film and White Burlap--Polyethylene Sheeting For Curing Concrete*  
*Section 1011 Burlap For Curing Concrete*  
*Section 1014 Joint Sealing Filler*  
*Section 1015 Preformed Joint Filler*  
*Section 1016 Preformed Polychloroprene*

*Elastomeric Joint Seals  
Section 1033 Aggregates*

Inspection Crew:

Project Manager  
Placement Inspector  
Plant Inspector

Inspection Equipment:

Slump Cone  
Air Meter (pressure)  
Cylinder Molds and Lids  
Rod  
Mallet  
Strike Off Bar  
Ruler  
3 m (10 ft) straightedge  
Anemometer  
Thermometer  
Hygrometer

Placement Procedures:

1. Preplacement check of equipment.
2. Check condition and placement of steel.
3. Check Form setting and alignment.
4. Check slab thickness.
5. Check deck for cleanliness
- @ 6. Have contractor wet *deck forms and grade under approach slabs* before concrete placement.

(Note: It's best to place deck and approach slabs at the same time.)

7. Test concrete for air content and make cylinders when mix changes, as a minimum according to Sampling Guide.
8. Watch concrete placement for compliance with specifications.
9. Do not use water as a finishing aid; use an approved chemical finishing aid/evaporation retardant.
10. Check surface with straightedge. Remove depressions and irregularities.
11. Check tining operation.
12. Check cure operation.
13. Make sure a water service and tanks are available to soak burlap.

Construction Critical Area:

1. Take pictures of any pavement under the deck before work begins.
2. Maintain a uniform roll, of about 100 mm (4 inch), of concrete ahead of the front screed and a minimum of a 50 mm (2 inch) roll ahead of the rear screed.
3. The time between loads of concrete.
4. Trucks that segregate concrete or have cement balls must not be used.
5. Avoiding placement when temperatures and wind velocities may cause plastic shrinkage cracking.

- @ (SSHC Table 706.01)
- 6. *Vibrate concrete uniformly. Establish good pattern and adjust as necessary.*
- @ 7.6- The timing of cure application.

Safety Areas:

NDR Tests:

1. NDR T 23 Making and Curing concrete test specimens.
2. NDR T 119 Slump of Portland Cement Concrete.
3. NDR T 141 Sampling of Fresh Concrete.
4. NDR T 152 Air Content of Freshly Mixed Concrete by the Pressure Method.

#### **701.04 STEEL STRUCTURES CHECKLIST**

SSHC References:

See SSHC Table 708.01

Other References:

AWS Standard Specifications. (ANSI/AASHTO/AWS D1.5 Bridge Welding Code)

Inspection Crew:

Fabrication Inspector  
Project Manager (PM)  
Lab Inspector

Inspection Equipment:

Skidmore-Wilhem Calibrator

Shop Procedures:

1. Check Fabricators QC Plan.
2. Make sure QC Plan is followed.
3. The mill order list or the Certified Mill Test Reports must be furnished before fabrication begins.
4. Document all actions not in compliance with the QC Plan or Standard AWS procedures.
5. Welding symbols are shown in Section 708.

Field Construction  
Procedures:

1. Confirm steel was inspected in the shop.
2. Sample bolts and send to M&T.
3. Heavy hexhead bolts require heavy hexhead nuts and a hardened washer under the element that is turned.
4. Check all bolts, washers, and nuts to make sure there is proper and correct marking on each. (See CM Subsection 704.03)
5. M & T personnel will calibrate the contractor's wrenches but they need at least 7-days advance notice.
6. Before the contractor begins steel erection, the Project Manager will make a final check of span lengths, skew angles, and bearing point elevations.
7. Also, take pictures of pavement under any structure where equipment will be lifting members.
8. Lead sheets (3 mm (1/8 inch) thick) shall be placed between steel and concrete at all bearing points.

9. Rockers, rollers, expansion devices, etc., shall be set according to the temperature at time of installation. (See Plans.)
10. Check matchmarks on all girders, separators, angle braces, etc.
11. Verify that drift pins do not enlarge holes or distort the metal.
12. Stop the contractor from hammering if it appears the metal will be damaged or injured.
13. The Construction Division will be notified of all major misfits and determine what procedures will be allowed.

**701.05 CONCRETE BRIDGE DECK REPAIR WITH SILICA FUME CONCRETE**

SSHC References:

- Section 710 -- Concrete Bridge Deck With Silica Fume Concrete*
- Section 1002 -- Portland Cement Concrete*
- Section 1010 -- White Opaque Polyethylene Film and White Burlap--Polyethylene Sheeting For Curing Concrete*
- Section 1011 -- Burlap For Curing Concrete*
- Section 1014 -- Joint Sealing Filler*
- Section 1015 -- Preformed Joint Filler*
- Section 1016 -- Preformed Polychloroprene Elastomeric Joint Seals*
- Section 1033 -- Aggregates*

Inspection Crew:

- Placement Inspector
- Plant Inspector

Inspection Equipment:

- Slump Cone
- Air Meter (pressure)
- Cylinder Molds and Lids
- Rod
- Mallet
- Strike Off Bar
- Ruler
- 3 m (10 ft) straightedge
- Anemometer
- Thermometer
- Hygrometer*

@

Placement Procedures:

1. Preplacement check of equipment.
2. Check condition and placement of steel.
3. Check Form setting and alignment.
4. Check slab thickness.
5. Check deck for cleanliness.
6. Have contractor wet deck and forms before concrete placement.
7. Test concrete for air content and make cylinders when mix changes, as a minimum according to Sampling Guide.

8. Watch concrete placement for compliance with specifications.
9. Do not use water as a finishing aid; use an approved chemical finishing aid/evaporation retardant.
10. Check surface with straightedge. Remove depressions and irregularities.
11. Check tining for conformance to specification.
12. Check cure operation.

Construction Critical Area:

1. Check finish machine (template & rails).
2. Check repair areas.
3. Deck shall be uniformly wet, without puddles prior to placement.
4. Bonding grout shall not be allowed to dry out.
5. Maintain a uniform roll, of about 100 mm (4 inch), of concrete ahead of the front screed and a minimum of a 50 mm (2 inch) roll ahead of the rear screed.
6. The time between loads of concrete.
7. Trucks that segregate concrete or have cement balls must not be used.
8. Avoiding placement when temperatures and wind velocities may cause plastic shrinkage cracking (see SSHC Figure 710.01).
- @ 9. Fogging system should be operating from time concrete is finished until ~~the cure~~ *wet burlap* is in place.
10. Check tining operation.
- @ 11. The timing of ~~cure~~ *wet burlap* application.

Safety Areas:

NDR Tests:

1. NDR T 23 Making and Curing concrete test specimens.
2. NDR T 119 Slump of Portland Cement Concrete.
3. NDR T 141 Sampling of Fresh Concrete.
4. NDR T 152 Air Content of Freshly Mixed Concrete by the Pressure Method.

**701.06 CONCRETE BRIDGE DECK REPAIR WITH HIGH DENSITY LOW SLUMP CONCRETE**

SSHC References:

*Section 711 Concrete Bridge Deck With High Density Low Slump Concrete*  
*Section 1002 Portland Cement Concrete*  
*Section 1010 White Opaque Polyethylene Film and White Burlap--Polyethylene Sheeting For Curing Concrete*  
*Section 1011 Burlap For Curing Concrete*  
*Section 1014 Joint Sealing Filler*  
*Section 1015 Preformed Joint Filler*  
*Section 1016 Preformed Polychloroprene Elastomeric Joint Seals*  
*Section 1033 Aggregates*

Inspection Crew:

Placement Inspector

Inspection Equipment:

Nuclear Density Gauge & Operator  
Slump Cone  
Air Meter (pressure)  
Cylinder Molds and Lids  
Rod  
Mallet  
Strike Off Bar  
Ruler  
Yield Bucket  
Strike Off Plate  
Scale  
3 m (10 ft) straightedge  
Anemometer  
Thermometer  
*Hygrometer*

@

Placement Procedures:

1. Preplacement check of equipment. Calibrate the mobile mixer.
2. Calibrate nuclear density gauge.
3. Check condition of existing deck and steel.
4. Check Form setting and alignment.
5. Check slab thickness.
6. **The deck must be dry.**
7. Blow down deck ahead of grout for cleanliness.
8. Test concrete for air content and make cylinders when mix changes, as a minimum according to Sampling Guide.
9. Check concrete density according to Sampling Guide.
10. Watch concrete placement for compliance with specifications.
11. Do not use water as a finishing aid; use an approved chemical finishing aid/evaporation retardant.

**702.00 EXCAVATION FOR STRUCTURES (SSHC Section 702)**

**702.01 DESCRIPTION**

All excavation should be done as shown in the plans. Excavation is very dangerous work and appropriate OSHA regulations must always be observed (see SSHC Figure 701.01).

Inspector should be present when an area is being backfilled. The inspector should check to see that the backfill materials are as specified. The materials shall be placed as prescribed in the *SSHC Subsection 205.03 or 702.03* as appropriate.

Structure excavation includes all excavation, removal of obstruction, bailing, draining, pumping, sheathing, construction and removal of cofferdams, backfilling, compacting and disposal of any excess material necessary to construct the structure in question.

**702.02 MATERIAL REQUIREMENTS**

**Unsuitable Material Excavation (SSHC Subsection 702.05)**

When unstable material is encountered it shall be removed and backfilled with approved material. The material shall be measured in cubic meters (yds) before it is placed. Payment for the extra work material and all work involved will be made at 10% of the contact unit price for box culvert concrete (when gravel or rock is used). The inspector should make an inspection of all structure footings as they are being excavated by the contractor.

**702.03 CONSTRUCTION METHODS**

**Culvert Excavation (SSHC Subsection 702.03)**

All culverts should be constructed with a minimum of approximately 300 mm (12 inches) of cover exclusive of surfacing. An accepted method for obtaining specified bedding for these culverts is to require the contractor to furnish a template conforming to the dimensions of the culvert pipe. This template is then used for shaping the trench to the specified depth.

The inspector must be knowledgeable of the Occupational Safety and Health Act (OSHA) requirements concerning excavation and trenching. Pipe culvert excavation by OSHA definition would normally be considered a trench.

Never allow any part of a pipe culvert to rest on rock or other unyielding materials. When rock is encountered in the bottom of the trench, it shall be removed to a depth of at least 150 mm (6 inches) below the subgrade and back filled with suitable earth or sand.

The Specifications provide that where unstable subgrades are encountered under pipes or pipe-arch culverts, the unsuitable material shall be removed and the excavated area refilled with gravel, crushed rock, or other suitable material. When crushed rock is used, care should be taken to place the fine rock immediately beneath all metal pipe to prevent abrasion of the spelter coating. When gravel or crushed rock is used *in place of unsuitable material*, it will be measured in cubic meters before it is placed. Payment for furnishing, hauling and placing this material will be made at 10% of the contract unit price for concrete for box culverts. When box culverts are

@

not included in the contract, the NDR average unit price for box culvert concrete shall be used. (SSHHC Subsection 702.05)

**General Structure Backfilling** (SSHHC Subsection 702.03)

This operation may involve SSHHC Sections 205, 702, and Table 702.01. The inspector should insure that all applicable sections are followed. The compaction of backfill material close to structures must given special attention. Mechanical tampers should be operated carefully in such a manner as to obtain the required density without damaging the structure.

Before any material is placed, the area to be backfilled should be inspected for trash or perishable matter. The materials to be used for backfill should be given careful consideration. Only those that will produce a dense, well-compacted backfill should be used. Granular materials are desirable as much less effort is needed to compact them than clay.

When abutments are tied to an anchor or deadman by means of tie rods, care should be taken in the back filling operation. The backfill should be placed in layers, starting at the anchor or deadman and working toward the abutment. Hand tamping may be required around the tie rods, abutment and anchors.

Backfilling must not be started without the permission of the Project Manager and in the case of concrete structures not until test cylinders show a minimum strength of at least 14 MPa 80% of the design strength.

@

Backfill should be brought up evenly to the elevation shown in the plans. Granular material must be placed in not more than 200 mm (8 inch) layers (lifts) and should have sufficient moisture to facilitate compaction. Do not allow dumping of granular material directly from the truck into the excavation *if this will result in lifts/layers greater than 8 inches.*

@

Special attention should be given to culvert wingwalls and flumes to insure proper compaction to prevent erosion and possible washout. The soil should be brought up even with these walls so the surface water will flow over these walls and not along them. Heavy equipment should be kept 1 m (3 feet) or more away from these wingwalls. Compaction within 1 m (3 ft) of the wingwall shall be with pneumatic hand tampers or small hand operated vibratory plate compactors.

Backfill for Bridges - Moisture and density requirements for backfill which is to provide support for subsequent construction will be shown in the plans. Backfill which is not to support later construction shall be compacted to 95% of maximum density without definite moisture limits.



Backfill for Culverts - When backfilling pipe culverts, the lifts shall be deposited and compacted alternately on opposite sides of the pipe to avoid lateral displacement. The inspector should also watch for vertical displacement. This may occur when tamping adjacent to the lowest 90 degrees of the pipe and should be checked from the grade stakes as backfilling progresses. The pipe should be tied down if any uplift is noted. Necessary precautions should be taken against washing under the pipe in case of rain. Compacted dikes or temporary earth headwalls at the inlet end will often save removing and relaying the pipe after a heavy rain. All drainage structures in the process of construction should be carefully inspected for washouts at the sides and beneath the structures after rains.

Flowable fill is sometimes included in the plans for backfilling culverts. The plans will identify the locations and show the details for using the flowable fill. *SSHC Section 1003* defines Flowable Fill requirements.

**Concrete Seal Course** (*SSHC Subsection 702.03*)

@

When it is impossible to dewater the foundation bed or box culvert footing or if live springs develop within the area a seal course should be constructed below the elevation of the bottom of the footing. Concrete for seals constructed underwater shall contain 10% excess cement and be placed in accordance with *SSHC Subsection 704.03*. The concrete shall be allowed to harden a minimum of 72 hours after completing the final pour before unwatering and continuing work on the structure. Seepage through inadequate or poorly constructed cofferdams shall not be justification for placing a seal course.

**Foundations**

**Staking and Checking Locations of Structures**

**Check and Double Check**

- All measurements and skew angles must be independently checked. From past practice, "independently checked" meant having a second survey party come in, setup, and completely resurvey (verify) original staking. This method is still the most desirable; however, with our upgrading to total station equipment it is acceptable to either setup off to the side and recheck or "back into" the bridge starting up station after clearing the total station.
- Stakes used should be substantial and protected from disturbance. Offset stakes for each pier and abutment must be placed outside the area of contemplated work.

Any checks suggested by the contractor should be considered, since the site superintendent usually has a good idea of the structure layout in relation to existing features such as trees, old structures, etc. Each stake must be clearly marked to denote its function. Pier numbers must correspond with plan designations.

**Documentation**

A staking diagram for each structure must be recorded in a permanent survey field book. This sketch must show the exact location of each hub and the markings made on each guard stake. IT IS NOT COMPLETE UNLESS IT SHOWS THE MEASUREMENTS MADE AS CHECKS ON THE ACCURACY OF THE STAKING LAYOUT. Names of those in the staking party should be entered as well as the date, design and project numbers, location, type of structure, and any other pertinent information.

**Common Survey Errors to Avoid**

- A. Turning the wrong skew angle.
- B. Errors in measuring from piers to abutments (This should be detected by an overall check from abutment to abutment.)

There are two situations where the analyzer should be used:

Case 1. Contract documents require pile to be driven with the analyzer.

Case 2. Pile do not achieve bearing and there are unresolvable questions or conditions observed during driving.

## 703.02 CONSTRUCTION METHODS

### Pile Driving Constraints

@ Piles shall not be driven within 15 m (50 ft) of freshly placed concrete. Normally piles may *not* be driven near new concrete ~~the day after it~~ *until three days after the concrete was placed.*

### Splicing Pile--Welding Steel Pile

*SSHC Section 708* requires that all welds conform to the Structural Welding Code ANSI/AWS DI. 1-90 of the American Welding Society.

Only Shielded Metal Arc Welding (SMAW) and Flux Cored Arc Welding (FCAW) will be permitted for welding steel piles.

The welding electrode must be on the NDR Approved Products List.

### Steel Pile Cutoffs

~~*SSHC Section 703* states in part that portions of steel pile cutoffs used as extensions on the same contract will not be included with the cutoffs of the plan quantity piles.~~

@ ~~This requires that some method of identification of steel pile cutoffs must be established on each contract. It is suggested that a durable notation be made on each pile cutoff 1.5 m (5 ft) or more in length prior to cutting. A notation of Pier 2, Pile 11 (or more simply 2-11) made with paint would be a suitable notation to designate the cutoff from pile number 11 of Pier 2. If this pile cutoff were used at a later date as an extension, it would be a simple matter to identify the cutoff from the pile quantities of the footing from which the cutoff originated.~~

If the contractor feels the cutoff is long enough that they may use it on some future project, the Heat number should be placed on the cutoff and a number to indicate the project it came from.

### Weights of Prestressed Concrete Bearing Piling

For computing bearing capacity required on Form RD-209

Pile Type	Constant Section	Tapered Section
	Wt. per Lin. Ft. (Pounds)	Total Weight (Pounds)
I	148	None
II	200	None
III	173	None
IV	212	None
V	124	1740
VI	169	2500
VII	221	2950

This table is based on and is for use only with Standard Plan 1720-C-R2.

### Steel Pipe Pile Data

	ARMCO		Union Metal
	Size O.D. (ins)	12	12¾
Wall T. (ins.)	.188	.188	7 Ga.
Wt. per Lin. Ft. (lbs.)	23.72	25.16	25.3
Conc. per Lin. Ft. (C.Y.)	.0273	.0309	.0255

Union Metal 30' tapered Sec. Type F Total Wt. 589 Lbs. Conc. 0.55 Cu. Yd.

Size O.D. (ins)	14	14 (Nominal)
Wall T. (ins.)	.188	7 Ga.
Wt. per Lin. Ft. (lbs.)	27.66	29.5
Conc. per Lin. Ft. (C.Y.)	.0375	.0350

Union Metal 40' tapered Sec. Type F Total Wt. 895 Lbs. Conc. 0.95 Cu. Yd.

For Raymond step tapered pile, contact your District Construction Engineer.

@

### Driving Sequence of Piles

*The driving sequence of piles in a pier or bent can be important. The driving sequence can affect the way piles drive as well as the influence the new construction has on adjacent structures. This is especially true for displacement piles. For non-displacement piles, the driving sequence is generally not as critical.*

*The driving sequence of displacement pile groups should be from the center of the group outward or from one side to the other side. The preferred driving sequence of the displacement pile group shown in Figure 24.16 would be (a) by the pile number shown, (sequence 1), (b) by driving each row starting in the center and working outward (sequence 2), or (c) by driving each row starting on one side of the group and working to the other side (sequence 3).*

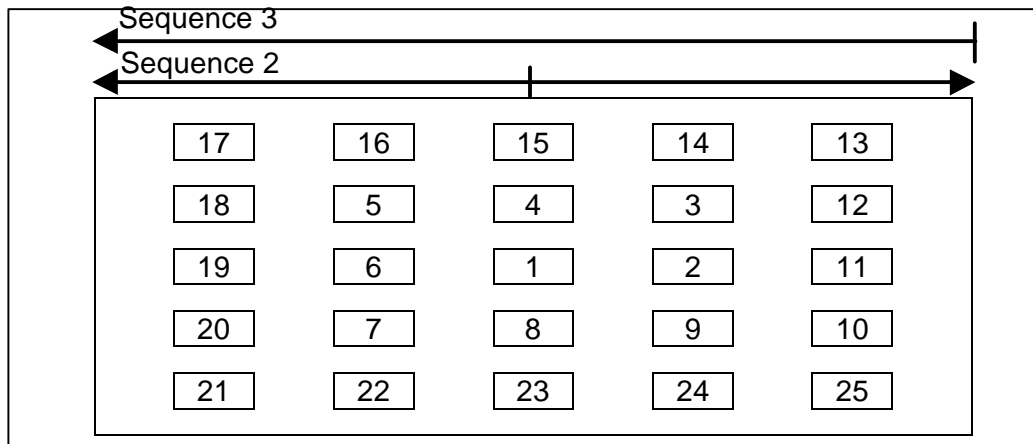

Figure 24.16 Driving Sequence of Displacement Pile Groups (after Passe, 1994)

@ Omar Qudus is responsible for the Geotechnical Section.

*The following guidelines for Single Acting Diesel Hammer are provided to assist you. If there is a need for a different type of hammer inspection guideline, please contact the Geotechnical Section.*

*It is very important to field check the hammer systems provided by the contractor to the hammer data sheets after they are approved by the Geotechnical Section. Prior to pile driving, please verify cap weight and size and condition of the hammer cushion material as shown on the hammer data sheets.*

### **INSPECTION OF PILES PRIOR TO AND DURING INSTALLATION**

*The inspection will be different for each type of pile. Shop plans are required for sheet piles, but usually are not required for H-piles, concrete-piles or pipe-piles.*

@ *When MSE walls are being constructed, at times the soil conditions may require additional considerations. A note is sometimes included on our plans that states the MSE Wall Must Be Built Before Piles Are Driven. This note is usually applicable when the embankment behind the MSE wall is constructed as a fill. The note also usually specifies that the MSE wall cannot be constructed until the embankment has reached 95+% of its anticipated settlement. The concern here is that the granular backfill material will settle further and the embankment is also able to settle some additional amount due to the granular backfill load. The combined effect on the piling is to cause a downward load on the piling that will reduce the piling's capacity to resist the live and dead loads from the roadway.*

### **PRECAST CONCRETE PILES**

@ *The following is a list of items for prestressed concrete piles to be inspected at the construction site:*

- a. *The piles should be of the specified length and section. The inspector must be assured that a minimum concrete strength has been obtained. If the piles are to be spliced on the site, the splices should meet the specified requirements (type, alignment, etc.).*
- b. *Piles should be inspected for cracks or spalling. There should be no evidence that any pile has been damaged during shipping to the site, or during unloading of piles at the site. Lifting hooks are generally cast into the piling at pick-up points. Piles should be unloaded by properly sized and tensioned slings attached to each lifting hook.*
- c. *The piles should be stored properly. When piles are being placed in storage, they should be stored above ground on adequate blocking in a manner which keeps them straight and prevents undue bending stresses.*
- d. *The contractor should lift the piles into the leads properly and safely. Cables looped around the pile are satisfactory for lifting. Chain slings should never be permitted. Cables should be of sufficient strength and be in good condition. Frayed cables are unacceptable and should be replaced. For shorter piles, a single pick-up point may be acceptable. The pick-up point locations should be as specified by the casting yard. For longer piles, two or more pick-up points at designated locations may be required.*
- e. *The pile should be free to twist and move laterally in the helmet.*
- f. *Piles should have no noticeable cracks when placed in leads or during installation. Spalling of the concrete at the top or near splices should not be evident.*

@

### **Steel H-Piles**

*The following should be inspected at the construction site:*

- a. *The piles being driven must be oriented with flanges in the correct direction as shown on the plans. Because the lateral resistance to bending of H-piles is considerably more in the direction perpendicular to flanges, the correct orientation of H-piles is very important.*
- b. *The piles should be of the specified steel grade, length, or section/weight.*
- c. *Pile points, if required for pile toe protection, should be as specified.*
- d. *Splices should be either proprietary splices or full penetration groove welds as specified. The top and bottom pile sections should be in good alignment before splicing.*
- e. *Pile point attachments and splices must be welded properly.*
- f. *There should be no observable pile damage, including deformations at the pile head.*

### **Steel Pipe Piles**

*The following should be inspected at the construction site:*

- a. *The piles should be of specified steel grade, length, or minimum section/weight (wall thickness) and either seamless or spiral welded as specified.*
- b. *Piles should be driven either open-ended or closed-ended. Closed-ended pipe piles should have bottom closure plates or conical points of the correct size (diameter and thickness) and be welded on properly, as specified. Open-end pipe piles should have cutting shoes that are welded on properly.*
- c. *The top and bottom pile sections should be in good alignment before splicing. Splices or full penetration groove welds should be installed as specified.*
- d. *There should be no observable pile damage, including deformations at the pile head. After installation, closed-end pipes should be visually inspected for damage or water prior to filling with concrete.*

### **Steel Sheet Piles**

- a. *The sheet piles must meet thickness, section models, steel grade, length and width requirements as shown in our plans.*
- b. *Sheet pile length should be measured so that analysis of obstructions to driving can be properly accomplished.*
- c. *Sheet piles should be driven plumb or at the angle shown in the plans.*

@

### **INSPECTION OF DRIVING EQUIPMENT**

A typical driving system consists of crane, leads, hammer, hammer cushion, helmet, and in the case of concrete piles, a pile cushion. Each component of the drive system has a specific function and plays an important role in the pile installation. The project plans and specifications may specify or restrict certain items of driving equipment. The Geotechnical Section will approve the contractor's driving equipment and determine conformity with the plans and specifications. The inspector must be sure the equipment used is what was approved.

The following checklist will be useful in the inspection of driving equipment before driving:

1. The pile driving hammer should be the specified type/size.

The inspector should make sure for single acting air/steam or hydraulic hammers that the contractor uses the proper size external power source and that, for adjustable stroke hammers, the stroke necessary for the required energy be obtained. For double acting or differential air/steam or hydraulic hammers, the contractor must again obtain the proper size external power source and the operating pressure and volume must meet the hammer manufacturer's specification.

2. The hammer cushion being used should be checked to confirm it is of the approved material type, size and thickness.

The main function of the hammer cushion is to protect the hammer itself from fatigue and high frequency accelerations which would result from steel to steel impact with the helmet and/or pile. The hammer cushion should have the proper material and same shape/area to snugly fit inside the helmet (drive cap). If the cushion diameter is too small, the cushion will break or badly deform during hammer blows and become ineffective. The hammer cushion must not be excessively deformed or compressed. Some air/steam hammers rely upon a certain total thickness (of cushion plus striker plate) for proper valve timing. Hammers with incorrect hammer cushion thickness may not operate, or will have improper kinetic energy at impact. Since it is difficult to inspect this item once the driving operation begins, it should be checked before the contractor starts pile driving on a project as well as periodically during production driving on larger projects.

3. The helmet (drive cap) should properly fit the pile.

The purpose of the helmet is to hold the pile head in alignment and transfer the impact concentrically from the hammer to the pile. The helmet also houses the hammer cushion, and must accommodate the pile cushion thickness for concrete piles. The helmet should fit loosely to avoid transmission of torsion or bending forces, but not so loosely as to prevent the proper alignment of hammer and pile. Helmets should ideally be of roughly similar size to the pile diameter. Although generally discouraged, spacers may be used to adapt an oversize helmet, provided the pile will still be held concentrically with the hammer. A properly fitting helmet is important for all pile types, but is particularly critical for precast concrete piles. A poorly fitting helmet often results in pile head damage. Check and record the helmet weight for conformance to wave equation analysis or for future wave equation analysis. Larger weights will reduce the energy transfer to the pile.

@

4. *The pile cushion should be of correct type material and thickness for concrete piles.*

*The purpose of the pile cushion is to reduce high compression stresses, to evenly distribute the applied forces to protect the concrete pile head from damage, and to reduce the tension stresses in easy driving. Pile cushions for concrete piles should have the required thickness determined from a wave equation analysis but not less than 100 mm. A new plywood, hardwood, or composite wood pile cushion, which is not water soaked, should be used for every pile. The cushion material should be checked periodically for damage and replaced before excessive compression (more than half the original thickness), burning or charring occurs. Wood cushions may take only about 1,000 to 2,000 blows before they deteriorate. During hard driving, more than one cushion may be necessary for a single pile. Longer piles or piles driven with larger hammers may require thicker pile cushions.*

5. *Predrilling, jetting or spudding equipment, if specified or permitted, should be available for use and meet the requirements. The depth of predrilling, jetting or spudding should be very carefully controlled so that it does not exceed the allowable limits. Predrilling, jetting, or spudding below the allowed depths will generally result in a reduced pile capacity, and the pile acceptance may become questionable.*

6. *A lead system must be used.*

*The leads perform the very important function of holding the hammer and pile in good alignment with each other. Poor alignment reduces energy transfer as some energy is then imparted into horizontal motion. Poor alignment also generally results in higher bending stresses and higher local contact stresses which can cause pile damage. This is particularly important at end of driving when driving resistance is highest and driving stresses are generally increased.*

#### **INSPECTION OF DRIVING EQUIPMENT DURING INSTALLATION**

*The main purpose of inspection is to assure that piles are installed so that they meet the driving criteria and the pile remains undamaged. The driving criteria is often defined as a minimum driving resistance as measured by the blow count in blows per inch. The driving criteria is to assure that piles have the desired capacity. However, the driving resistance is also dependent upon the performance of the pile driving hammer. The driving resistance will generally be lower when the hammer imparts higher energy and force to the pile, and the driving resistance will be higher if the hammer imparts lower energy and force to the pile. High driving resistances can be due either to soil resistance or to a poorly performing hammer. Thus, for the inspector to assure that the minimum driving criteria has been met and, therefore, the capacity is adequate, the inspector must evaluate if the hammer is performing properly.*

*Each hammer has its own operating characteristics; the inspector should not blindly assume that the hammer on the project is in good working condition. In fact, two different types of hammers with identical energy rating will not drive the same pile in the same soil with the same driving resistance. In fact, two supposedly identical hammers (same make and model) may not have similar driving capability due to several factors including differing friction losses, valve timing, air supply hose type-length-condition, duel type and intake amount, and other maintenance status items. The inspector should become familiar with the proper operation of the hammer(s) used on site. The inspector may wish to contact the hammer manufacturer or supplier who generally will welcome the opportunity to supply further information.*

@

### **Single Acting Diesel Hammers**

- a. *Determine/confirm that the hammer is the correct make and model. Check for and record any identifying labels as to hammer make, model and serial number.*
- b. *Make sure all exhaust ports are open with all plugs removed.*
- c. *Inspect the recoil dampener for condition and thickness. If excessively worn or improper thickness (consult manufacturer) it should be replaced. If the recoil dampener is too thin, the stroke will be reduced. If it is too thick, or if cylinder does not rest on dampener between blows, the ram could blow out the hammer top and become a safety hazard.*
- d. *Check that lubrication of all grease nipples is regularly made. Most manufacturers recommend the impact block be greased every half-hour of operation.*
- e. *As the ram is visible between blows, check the ram for signs of uniform lubrication and ram rotation. Poor lubrication will increase friction and reduce energy to the pile.*
- f. *Determine the hammer stroke, especially at end of driving or beginning of restrike. A “jump stick” attached to the cylinder is a safety hazard and should not be used. The stroke can be determined by a saximeter which measures the time between blows and then calculates the stroke. The hammer stroke can also be calculated from this formula if the number of blows per minute (bpm) is manually recorded.*

$$h \text{ [meters]} = (4400/[\text{bpm}^2]) - 0.90$$

*The calculated stroke may require correction for batter or inclined piles. The inspector should always observe the ram rings and visually estimate the stroke using the manufacturer’s chart.*

- g. *As the driving resistance increases, the stroke should also increase. At the end of driving, if the ram fails to achieve the correct stroke (part of the driving criteria from a wave equation analysis), the cause could be lack of fuel. Most hammers have adjustable fuel pumps. Some have distinct fuel settings, others are continuously variable, and some use a pressure pump. Make sure the pump is on the correct fuel setting or pressure necessary to develop the required stroke. The fuel and fuel line should be free of dirt or other contaminants. A clogged or defective fuel injector will also reduce the stroke and should be replaced if needed.*
- h. *Low strokes could be due to poor compression caused by worn or defective piston or anvil rings. Check compression by raising the ram, and with the fuel turned off, allowing the ram to fall. The ram should bounce several times if the piston and anvil rings are satisfactory.*



@

- i. *Watch for signs of preignition. When a hammer preignites, the fuel burns before impact, requiring extra energy to compress gas and leaving less energy to transfer to the pile. In long sustained periods of driving, or if the wrong fuel with a low flash point is used, the hammer could overheat and preignite. When preignition occurs, less energy is transferred and the driving resistance rises, giving a false indication of high pile capacity. If piles driven with a cold hammer drive deeper or with less hammer blows, or if the driving resistances decrease after short breaks, preignition could be the cause and should be investigated. Dynamic testing is the preferable method to check for preignition.*
- j. *For some diesel hammers, the total thickness of hammer cushion and striker plate must match the hammer manufacturer's recommendation and the hammer cushion cavity in the helmet for proper fuel injection and hammer operation. This total thickness must be maintained.*
- k. *Make sure the helmet stays properly seated on the pile and that the hammer and pile maintain alignment during operation.*
- l. *The hammer hoist line should always be slack, with the hammer's weight fully carried by the pile. Excessive tension in the hammer hoist line is a safety hazard and will reduce energy to the pile. Leads should always be used.*
- m. *Some manufacturers void their warranty if the hammer is consistently operated above 100 blows per 250 mm of penetration beyond short periods, such as those required when toe bearing piles are driven to rock. Therefore, in prolonged hard driving situations, it may be more desirable to use a larger hammer or stiffer pile section.*
- n. *Common problems and problem indicators for single acting diesel hammers are presented in the following table.*

<b>COMMON PROBLEMS AND PROBLEM INDICATORS FOR SINGLE ACTING DIESEL HAMMERS (from Williams Earth Sciences, 1995)</b>	
<b>Common Problems</b>	<b>Indicators</b>
<i>Water in fuel.</i>	<i>Hollow sound, white smoke.</i>
<i>Fuel lines clogged.</i>	<i>No smoke or little gray smoke.</i>
<i>Fuel pump malfunctioning.</i>	<i>Inconsistent ram strokes, little gray smoke or black smoke.</i>
<i>Fuel injectors malfunctioning.</i>	<i>Inconsistent ram strokes, little gray smoke or black smoke.</i>
<i>Oil low.</i>	<i>Blows per minute rate is lower than specified.</i>
<i>Oil pump malfunctioning.</i>	<i>Blows per minute rate is lower than specified.</i>
<i>Water in combustion chamber.</i>	<i>Hollow sound, white smoke.</i>
<i>Piston rings worn.</i>	<i>Low strokes.</i>
<i>Tripping device broken.</i>	<i>Pawl or pin used to lift piston does not engage piston. Pawl engages but does not lift piston.</i>
<i>Overheating.</i>	<i>Paint and oil on cooling fins start to burn/sound changes.</i>

@

**Field Driving Problem**

In the following table, there is a list of common field problems and possible solutions.

<b>COMMON PILE INSTALLATION PROBLEMS &amp; POSSIBLE SOLUTIONS</b>	
<b>Problem</b>	<b>Possible Solutions</b>
<i>Piles encountering refusal driving resistance (blow count) above minimum pile penetration requirements.</i>	<i>Have wave equation analysis performed and check the pile has sufficient driveability and that the driving system is matched to the pile. If the pile and driving system are suitably matched, check driving system operation for compliance with manufacturer's guidelines. If no obvious problems are found, dynamic measurements should be made to determine if the problem is driving system or soil behavior related. Driving system problems could include preignition, preadmission, low hammer efficiency, or soft cushion. Soil problems could include greater soil strength than anticipated, temporarily increased soil resistance with later relaxation (required restrrike to check), large soil quakes, or high soil damping.</i>
<i>Piles driving significantly deeper than estimated pile penetration depths.</i>	<i>Soil resistance at the time of driving probably is lower than anticipated or driving system performance is better than anticipated. Have wave equation analysis performed to assess ultimate pile capacity based on the blow count at the time of driving. Perform restrrike tests after an appropriate waiting period to evaluate soil strength changes with time. If the ultimate capacity based on restrrike blow count is still low, check drive system performance and restrrike capacity with dynamic measurements. If drive system performance is as assumed and restrrike capacity low, the soil conditions are weaker than anticipated. Foundation piles will probably need to be driven deeper than originally estimated or additional piles will be required to support the load. Contact the structural engineer/designer for recommended change.</i>
<i>Abrupt change or decrease in driving resistance (blow count) for bearing piles.</i>	<i>If borings do not indicate weathered profile above bedrock/bearing layer, then pile toe damage is likely. Have wave equation analysis performed and evaluate pile toe stress. If calculated toe stress is high and blow counts are low, a reduced hammer energy (stroke) and higher blow count could be used to achieve capacity with a lower toe stress. If calculated toe stress is high at high blow counts, a different hammer or pile section may be required. For piles that allow internal inspection, reflect light to the pile toe and tape the length inside the pile for indications of toe damage. For piles that cannot be internally inspected, dynamic measurements could be made to evaluate problem or pile extraction could be considered for confirmation of a damage problem.</i>
<i>Driving resistance (blow count) significantly lower than expected during driving.</i>	<i>Review soil borings. If soil borings do not indicate soft layers, pile may be damaged below grade. Have wave equation analysis performed and investigate both tensile stresses along pile and compressive stresses at tie. If calculated stresses are within allowable limits, investigate possibility of obstructions/uneven toe contact on hard layer or other reasons for pile toe damage. If pile was spliced, re-evaluate splice detail and field splicing procedures for possible splice failure.</i>
<i>Vertical (heave) or lateral movement of previously installed piles when driving new piles.</i>	<i>Pile movements likely due to soil displacement from adjacent pile driving. Contact geotechnical engineer for recommended action. Possible solutions include re-driving of installed piles, change in sequence of pile installation, or predrilling of pile locations to reduce ground movements. Lateral pile movements could also result from adjacent slope failure in applicable conditions.</i>

@

<b>COMMON PILE INSTALLATION PROBLEMS &amp; POSSIBLE SOLUTIONS</b>	
<b>Problem</b>	<b>Possible Solutions</b>
<i>Piles driving out of alignment tolerance.</i>	<i>Piles may be moving out of alignment tolerance due to hammer-pile alignment control or due to soil conditions. If due to poor hammer-pile alignment control, a pile gate, template or fixed lead system may improve the ability to maintain alignment tolerance. Soil conditions such as near surface obstructions (see subsequent section) or steeply sloping bedrock having minimal overburden material (pile point detail is important) may prevent tolerance from being met even with good alignment control. In these cases, survey the as-built condition and contact the Geotechnical engineer for recommended action.</i>
<i>Piles driving out of location tolerance.</i>	<i>Piles may be moving out of location tolerance due to hammer-pile alignment control or due to soil conditions. If due to poor hammer-pile alignment control, a pile gate, template or fixed lead system may improve the ability to maintain location tolerance. Soil conditions such as near surface obstructions (see subsequent section) or steeply sloping bedrock having minimal overburden material (pile point detail is important) may prevent tolerances from being met even with good alignment control. In these cases, survey the as-built condition and contact the Geotechnical engineer for recommended action.</i>
<i>Piles encountering shallow obstructions.</i>	<i>If obstructions are within 3 feet of working grade, obstruction excavation and removal is probably feasible. If obstructions are at deeper depth, are below the water table, or the soil is contaminated, excavation may not be feasible. Spudding or predrilling of pile locations may provide a solution with method selection based on the type of obstructions and soil conditions.</i>
<i>Pile encountering obstructions at depth.</i>	<i>If deep obstructions are encountered that prevent reaching the desired pile penetration depth, contact the structural engineer/designer for remedial design. Ultimate capacity of piles hitting obstructions should be reduced based upon pile damage potential and soil matrix support characteristics. Additional foundation piles may be necessary.</i>
<i>Concrete piles develop partial horizontal cracks in easy driving.</i>	<i>Check hammer-pile alignment since bending may be causing the problem. If the alignment appears to be normal, tension and bending combined may be too high. The possible solution is as above with complete cracks.</i>
<i>Concrete pile spalling or slabbing near pile head.</i>	<i>Have Geotechnical Section determine pile head stress for observed blow count and compare with allowable stresses. If high calculated stress, add pile cushioning. If low calculated stress, investigate pile quality, hammer performance, hammer-pile alignment.</i>
<i>Concrete piles develop complete horizontal cracks in easy driving.</i>	<i>Have Geotechnical Section determine tension stresses along pile for observed blow counts. If high calculated tension stresses, add cushioning or reduce stroke. If low calculated tension stresses, check hammer performance and/or perform measurements.</i>
<i>Concrete piles develop complete horizontal cracks in hard driving.</i>	<i>Have Geotechnical Section determine tension stresses along pile. If high calculated tension stresses, consider heavier ram. If low calculated tension stresses, take measurements and determine quakes which are probably higher than anticipated.</i>
<i>Concrete piles develop partial horizontal cracks in easy driving.</i>	<i>Check hammer-pile alignment since bending may be the problem. If alignment appears to be normal, tension and bending combined may be too high; solution will then be the same as for complete cracks above.</i>
<i>Steel pile head deforms, timber pile top mushrooms.</i>	<i>Check helmet size/shape; check steel strength; check evenness of pile head, banding of timber pile head. If okay, have Geotechnical Section determine pile head stress. If calculated stress is high, reduce hammer energy (stroke) for low blow counts; for high blow counts, different hammer or pile type may be required.</i>
<i>Unexpectedly low blow counts during pile driving.</i>	<i>Investigate soil borings; if soil borings do not indicate soft layers, pile may be damaged below grade. Have Geotechnical Section investigate both tensile stresses along pile and compressive stresses at toe. If calculated stresses are acceptable, investigate possibility of obstructions/uneven toe contact on hard layer or other reasons for pile toe damage.</i>

@

<b>COMMON PILE INSTALLATION PROBLEMS &amp; POSSIBLE SOLUTIONS</b>	
<b>Problem</b>	<b>Possible Solutions</b>
<i>Higher blow count than expected.</i>	<i>Have the Geotechnical Section review the wave equation analysis and check that all parameters were reasonably considered. Check hammer and driving system. If no obvious defects are found in driving system, field measurements should be taken. Problem could be preignition, preadmission, low hammer efficiency, soft cushion, large quakes, high damping, greater soil strengths, or temporarily increased soil resistance with later relaxation.</i>
<i>Lower blow count than expected.</i>	<i>Probably soil resistance is lower than anticipated. Have the Geotechnical Section assess soil resistance. Perform restrike testing (soil resistance may have been lot during driving), establish setup factor and drive to lower capacity. Hammer performance may also be better than anticipated, check, by measurement.</i>
<i>Diesel hammer stroke (bounce chamber pressure) higher than calculated.</i>	<i>The field observed stroke exceeds the calculated stroke by more than 10%. Compare calculated and observed blow counts. If observed are higher, soil resistance is probably higher than anticipated. If blow counts are comparable, have the Geotechnical Section reanalyze with higher combustion pressure to match observed stroke and assure that preignition is not a problem, e.g., by measurements.</i>
<i>Diesel hammer stroke (bounce chamber pressure) lower than calculated.</i>	<i>The field observed stroke is less than 90% of the calculated stroke. Check that ram friction is not a problem (ram surface should have well lubricated appearance). Compare calculated and observed blow count. If observed one is lower, soil resistance is probably lower than anticipated. If blow counts are comparable, reanalyze with lower combustion pressure to match observed hammer stroke.</i>
<i>Cannot find hammer in data file.</i>	<i>See if there is a hammer of same type, similar ram weight and energy rating and modify its data.</i>
<i>Cannot find an acceptable hammer to drive pile within driving stress and driving resistance limits.</i>	<i>Both calculated stresses and blow counts are too high. Increase pile impedance or material strength or redesign for lower capacities.  Alternatively, check whether soil has potential for setup. If soil is fine grained or known to exhibit setup gains after driving, then end of driving capacity may be chosen lower than required. Capacity should be confirmed by restrike testing or static load testing.</i>

@

# SINGLE ACTING HAMMER INSPECTION CHECKLIST

(For PM Use Only)

Project/Pile: \_\_\_\_\_

Hammer Name: \_\_\_\_\_

Date: \_\_\_\_\_

Serial No: \_\_\_\_\_

Conditions: \_\_\_\_\_

OBJECT

REQUIREMENTS

OBSERVATIONS

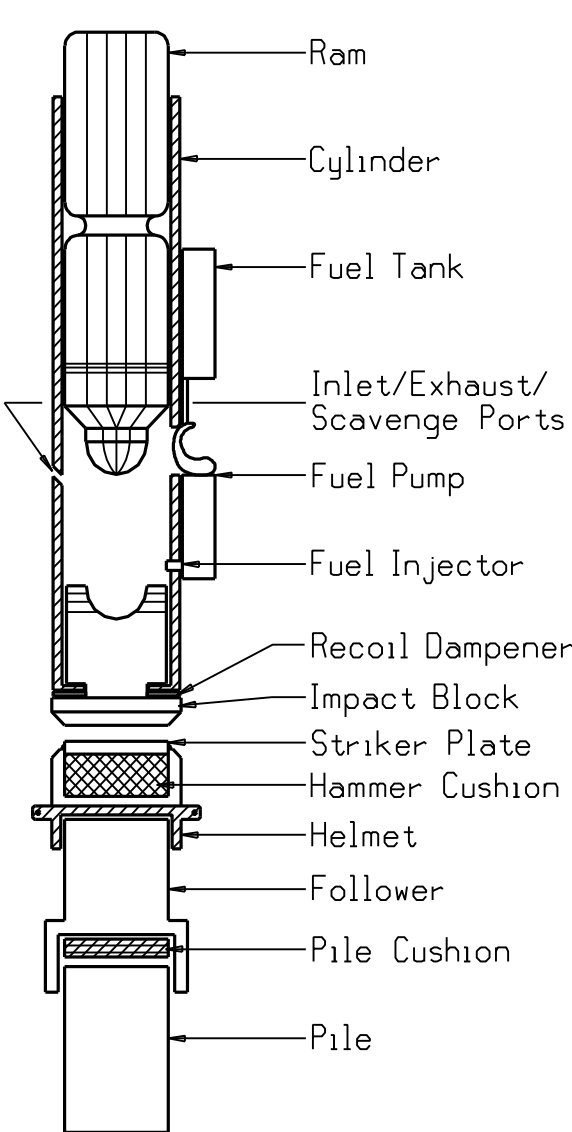

Ram Lubricated?	Yes / No
Exhaust Ports Open?	Yes / No
Fuel Pump	Hammer Setting _____
Recoil Dampener Undamaged?	Yes / No
Impact Block Lubricated?	Yes / No
Striker Plate	t= _____ D= _____
Hammer Cushion	t= _____ D= _____ Material _____ How long in use? _____
Helmet	Type or Weight? _____
Pile Cushion	Material _____ t= _____ Size _____ How long in use? _____

- Concrete arch bridges.
- Support of girders or other large structural elements when required.
- Unusual or complicated work indicated in the plans.
- Support of girders over or under active railroad tracks.
- Support of girders carrying traffic or extending over highways or streets carrying traffic.

### Submitting Plans

**NOTE:** Submission of falsework plans does not imply that OSHA regulations are satisfied, that the NDR, or the Project Manager assumes any liability for the falsework. Inspectors should not give the contractors advice on how to construct the falsework.

### Falsework Inspection

Contract requirements governing falsework construction are contained in *SSHC Subsection 704.03, paragraph 7.*

The Project Manager should observe the falsework as it is erected to ensure that:

- Only sound materials are used.
- Quality work is used.
- @ • During concrete pour, the falsework will carry the load. (*More than 1/2" movement is bad.*)

**NOTE:** Any inspection and/or acceptance by the Project Manager is not intended to relieve a contractor of responsibility under the contract for falsework design and construction.

By specification, a contractor is responsible for proper evaluation of the quality of their falsework materials. However, the Project Manager should not permit use of any material, when there is doubt as to the materials ability to safely carry the load. If there is any question, the contractor should be required to perform a load test or furnish other evidence of structural adequacy.

Timely inspection is essential. Falsework deficiencies should be brought to the contractor's attention at once. Deficiencies include:

- Poor quality work.
- Use of unsound or poor quality materials.
- Construction which does not conform to the contractor's falsework drawings.

Identification by the contractor applies not only to jacks, beam hangers, overhang brackets, and similar devices, but to all vertical steel shoring systems as well.

Manufactured products such as tubular steel shoring and steel overhang brackets are particularly vulnerable to damage by continual reuse. Fabricated units in which individual members are bent, twisted, or broken will have a substantial reduction in load carrying capacity. Steel shoring materials should be examined carefully prior to use. Shoring components should not be used if they are heavily rusted, bent, dented, or have broken/damaged welds or other defects. Connections, in particular, should be examined for evidence of cracked or broken welds. Miscellaneous components such as screw jack extensions, clamps, and adjusting pins should be inspected as well.

Proprietary scaffolding must be used as intended and not subjected to additional stresses or conditions for which it was not originally designed and tested.

#### D. Cable Bracing

Cable bracing systems must be carefully inspected to ensure that field installation conforms to details shown on the falsework drawings. This is particularly important with respect to the location and method of cable attachment to any falsework.

Prior to installation, each cable should be inspected to verify that the type, size, and condition (new or used) are consistent with design assumptions. Used cable should be inspected for strength-reducing flaws. Use of obviously worn, frayed, kinked, or corroded cable should not be permitted.

Particular attention should be paid to cable clamp fasteners. Improperly installed clamps will reduce the safe working load by as much as 90 percent. Also, the omission of the thimble in a loop connection will reduce the safe working load by approximately 50 percent. After installation, clamps should be inspected periodically and tightened as necessary to ensure their effectiveness.

@ ~~This phrase may seem nonsensical, it defines how to install clamps since~~ A cable clamp has two parts - the "U-Bolt" and the "Saddle." Also a cable has two parts, the wrapped non-continuous end (dead end) and the continuous portion which supports the load (live side). Therefore: Always put the cable clamp's "saddle" on the live side and the "U-bolt" over the "dead end."

#### Project Quality

High quality work, particularly in such details as wedges, fasteners, bracing, friction collars, jack extensions, etc., is critical to the proper performance of falsework. Accordingly, construction details should receive close attention from the project inspector.

##### A. Timber Construction

The following checklist is included as a guide to points which require special consideration:

Size and spacing of falsework members must agree with details shown on the falsework drawings.

### **Falsework and Centering**

It is the contractor's responsibility to provide form work adequate to support the dead load of the fresh concrete. However, the inspector shall consult with the contractor and the Project Manager concerning any form work which he/she has reason to believe is inadequate to support the load capacity. In calculating the strength of centering, a mass of 2400 kg/m<sup>3</sup> (150 lb/ft<sup>3</sup>) shall be assumed for fresh concrete.

All falsework shall be rigidly braced and cross braced. Timber piling shall be free from defects with at least a 175 mm (7 inches) butt and a 125 mm (5 inches) tip, measured under the bark. The contractor shall provide jacks or suitable wedges to take up any settlement in the form work during the placing of the concrete. When setting grades for falsework or structure forms, allow 1.5 mm (1/16 inch) settlement or "take-up" for each lap in the falsework timbers.

@ *Build falsework for slab bridges with 1/8 inch camber for each 10' of span. Deflection after forms are removed should bring deck back to the proper elevation.*

Settlement caused by the concrete loads may be checked as placing of the concrete progresses by means of vertical "telltails" fastened to the bottom of the floor form. When this settlement has reached the amount allowed for "take-up" in the falsework timbers, any further settlement should be prevented by means of the wedges or jacks previously noted. Any adjustments that have to be made must be completed before the concrete has taken its initial set. If adjustments are made after the concrete has set,

@ *the concrete may be damaged irreparably. (In general, if falsework settles more than ½ inch, the PM must investigate and determine the damage.)*

### **Removal of Falsework (SSHC Table 704.02)**

Specifications and applicable special provisions, contain specific criteria which must be met before falsework may be removed. Project Managers and inspectors should review these sections prior to falsework removal operations.

The Project Manager should discuss falsework removal methods and procedures at the preconstruction and/or prepour meeting. The need to provide for employee and public safety is of particular concern.

In general, all elements of the falsework bracing system must remain in place for the specified time period or until concrete attains the specific strength. In the case of cast-in-place, post tensioned construction, falsework elements must not be removed until stressing is completed.

### **Bridges-Steel Beam**

On bridges using weathering steel (A 588) for steel structures, the contractor shall:

- Use "high strength," A325M Type III bolts, A563 Grade DH3 nuts, and F463 Type III washers.
- Limit shop painting to only areas under expansion joints and all bearings. Shop painting will be with a Zinc-rich primer and a colored top coat. Field touch-up will be required for paint that is damaged and to fasteners in these areas and it will be done with same color and type of paint as the original painting.
- Require special care to assure concrete slobbers are eliminated (or at least removed) from steel surfaces before the concrete hardens. Washing with water is the preferred method of removing concrete slobbers.



## Bridge Diaphragms

Steel diaphragms, if allowed, are shown in the plans for prestressed beam structures. Shop drawings are required for steel diaphragms showing details of beam layouts, location of the diaphragms, and location of mounting holes.

High strength bolts for steel diaphragms shall be tightened by Turn-of-Nut method. (Refer to *SSHC Subsection 708.03* for information on proper bolt inspection and installation.) Inspection and field installation acceptance will be based on observing proper Turn-of-Nut procedures. (A tensioning device and inspection torque wrench is recommended, but will not be required.)

@ Concrete diaphragms *at piers of prestressed concrete girder bridges should be cast to 2/3 of their intended depth. The final 1/3 and the deck (bent plate separators) are then intended to be placed at the same time. monolithically with the deck slab.* However, there are instances where allowance has been given for specific diaphragms to be placed prior to slab placement. If there is a construction option shown in the plans, the diaphragm can be poured separate from the deck. Note the construction joint detail will show how to strike-off the surface. Consult with the Construction Division in situations where the contractor requests to place concrete diaphragms ~~before a deck placement.~~ *other than as shown in the plans.*

Contractor shop drawings are required to cover diaphragms.

## Girder Shims

### Definition

A girder shim is defined as the distance measured from top of girder to top of finished slab. There are three different types of bridges which we build that have girder shims. The first type is a steel girder bridge, either a rolled beam section or a plate girder section. The second type is a prestressed girder (NU Girder Section). The third type is a prestressed twin tee girder. When taking shim shots on a prestressed twin tee girder, they should be taken at the edges of the twin tee. Take shim shot on steel girders or NU girders along the girder centerline.

For each type, the definition of the girder shim is the same; girder shim is the distance measured from the top of girder to top of finished slab.

### Stages of the Girder Shim Process

The Bridge Division, upon completion of the design, will prepare the shim input forms. After the project has been let, we send these forms to the Project Manager. After the girders are erected and prior to forming the deck for the slab, shim shots are required to be taken. These shim shots should be taken at the bearings, field splices, and at 3 m intervals along the length of the girder. The shim shots can be recorded on the input forms.

The H.I. Elevation needs to be recorded by the inspector at the time the shim shots are taken.

The rod readings at each location are recorded on RDP Form 50a. This information is normally sent by computer to the Bridge Division.

### **High Range Water Reducing Admixtures (Type F)**

They are added to concrete with low-to-normal slump and water content to make high slump "flowable" concrete. Flowable concrete is a highly fluid, but workable concrete that can be placed with little or no vibration and can still be free of excessive bleeding or segregation. Flowable concrete has applications:

1. In areas of closely spaced and congested reinforcing steel.
2. In tremied concrete where "self consolidation" is desirable.
3. In pumped concrete to reduce pump pressure.
4. To produce low water/cement ratio - high strength concrete. High-range "super plasticizers" can reduce water content by about 12% to 30%.

#### **Rules-of-Thumb**

- The effect of most super plasticizers in increasing workability or flowable concrete is short lived. Typically, maximum is 30 to 60 minutes followed by a very rapid loss in workability.
- Typically, super plasticizers are added as split treatments (part at the plant part at the site). Sometimes the addition is totally at the site.
- Setting time may be affected depending on the brand used, dosage rate, and interaction with other admixtures.
- Excessively high slumps of 250 mm (10 inches) or more may cause segregation.
- High-slump, low water/cement super plasticized concrete has less dry-shrinkage than does high-slump high water/cement conventional concrete.
- Effectiveness of super plasticizer is increased with an increased amount of cement and/or increased fineness of cement.
- Effectiveness of water reducers on concrete is a function of their chemical composition, cement composition and fineness, cement content concrete temperature, and other admixtures being used.
- Some water reducing admixtures, such as lignosulfonates, may also entrain some air in the mix.

#### **Retarding Admixtures**

@

Retarding admixtures (retarders) are used to delay the initial set of concrete. High temperatures of fresh concrete 30°C (85°F) and up often cause an increased rate of hardening. Since retarders do not decrease the initial temperature of concrete, other methods of counteracting the effect of temperature must be used.

Record the temperature daily for 48 hours following the pour. Temperature readings below 10°C during the first 48 hours should be entered in the Field Book and reported to the District Construction Engineer for evaluation of possible damage or price adjustment.

### **Placing Concrete**

Concrete shall be proportioned, mixed and handled in accordance with the requirements of *SSHC Section 1002*. The inspector should also refer to the Materials and Tests Manual which outlines the method of proportioning, sampling and field testing the materials necessary for the production of concrete. The contractor shall organize his/her work so that the maximum interval between batches shall not exceed 30 minutes.

@ Concrete should not be placed in footings, columns, etc, until all pile driving within a radius of ~~7.62 m (25 50 feet)~~ has been completed. If concrete pours must be made within this area prior to the completion of pile driving, such concrete shall set at least three days before further driving is permitted within this radius. Concrete shall not be placed without special permission in steel pile shells for cast-in-place concrete piles for each bent, pier, or abutment until all the shells for that bent pier or abutment have been driven (*SSHC Section 703*).

When depositing concrete in the forms, segregation must be avoided. The mass of concrete should be generally free of surface cavities resulting from the trapping of air and water along the forms. Careful spading of concrete along vertical forms and tapping of the forms will usually release the air and water bubbles. Forms which are not mortar tight will leak cement paste and result in "sand streaking." Forms should be mortar tight to the maximum extent possible. Chutes shall be of metal or metal lined and of sufficient number to preclude the necessity of shifting the chutes. If necessary, the contractor shall leave holes in the forms for the entry of the chutes or pipes. Concrete must be deposited within 2.5 m (8 ft) horizontally of the place of its final location. Concrete shall not be dropped vertically more than 1.5 m (5 feet). Concrete in walls, footings, columns, etc, shall be placed in continuous horizontal layers not more than 450 mm (18 inches) thick and vibrated to a monolithic mass. Do not allow dried concrete to collect on forms or reinforcing bars where it will fall into the work.

Currently, four test cylinders are to be fabricated for each placement (generally, each day a set of cylinders is required). These test cylinders are then tested at ages of 7, 10, 14 and 28 days.

If the 7 day cylinder tests 25 MPa (3500 psi) or above, the 10 and 14 day cylinders need not be tested and can be discarded. If the 7 day cylinder should test less than 25 MPa, the 10, 14, and 28 day cylinders must be retained and tested.

### **Consolidation of Concrete**

@ *The contractor must establish a pattern for vibrating the concrete and ensure the pattern is followed across the entire deck.*

Consolidation of concrete should be accomplished by the use of a sufficient number of vibrators of a type approved by the Project Manager. The vibrators must be of such an intensity as to visibly affect one-inch slump concrete over a radius of 450 mm (18 inches). The contractor is required to furnish a tachometer for the purpose of checking the speed of the vibrator elements.

Lateral movement of the concrete by means of a vibrators shall be avoided. Over vibration is harmful and is evidenced by grout appearing in the concrete around the vibrator head. Insert and withdraw the vibrator slowly. It should not come in contact with reinforcing steel which extends into previously placed concrete nor should the vibrator head be placed in concrete which is taking its initial set.

### **Deck Concrete Temperature and Curing**

Subsection 706.03 identifies requirements for placing and curing concrete bridge floors. Of importance for this section are:

- @ • Plastic concrete, when placed, shall not exceed ~~32~~ 30°C (~~90~~ 86°F).
- The curing method requires "wet" burlap cure for three (3) days.
- @ • ~~Plastic, in addition to wet burlap, may be used the last two days of the cure period.~~

The placing of concrete will require close monitoring to comply with the specifications. Obtain a weather report to determine predicted air temperature, wind velocity, and relative humidity for the pour day.

- @ The above information should be discussed by the inspector, contractor, and ready mix plant operator before a deck pour. The pour should not be attempted if concrete temperature is predicted at 30°C (~~85~~ 86°F) or higher and predicted air temperature is above 30°C (~~85~~ 86°F).

### **Placement Considerations**

- @ A. If there is any doubt about the concrete temperature exceeding 30°C (~~85~~ 86°F), the contractor needs to identify measures which will be implemented to keep mix temperatures within specifications. If the contractor is not prepared to maintain a mix temperature below specifications, the pour should be postponed.

There are several ways concrete temperatures may be kept within specifications. They are:

- Scheduling placements during cooler times of the day.
- Wetting the aggregate stockpiles.
- Covering/shading the aggregate stockpiles.
- Maintaining a supply of portland cement on hand to preclude getting hot material from the supplier.
- Chilling the mixing water is one of the most effective ways to lower mix temperatures.
- Shaved ice can be used, however, the ready mix operator must submit a proposal for this to the Project Manager for review by the Construction Division.

**NOTE:**

1. No payment will be made for methods taken to keep concrete temperatures within specifications.
  2. If pour has to be delayed because of temperature, and pouring is the controlling operation, no working days will be charged.
- @ B. Location of permissible headers should be discussed with the contractor during the pour, it appears the temperature may exceed 30°C (~~85~~ 86°F).

General - The wind velocity temperature relationships stated in the specifications should be enforced to avoid loss of water from the concrete surface faster than it can be replaced by normal bleeding and to avoid the resultant formation of plastic shrinkage cracks. Anemometers and thermometers must be available on site to measure wind velocity and temperature.

Concrete in bridge floors shall be placed uniformly on both sides of the centerline and shall be placed continuously between specified joints. The sequence of placing shall be in accordance with the pouring diagram shown in the plans. If no pouring diagram is shown in the plans, concrete shall be placed as directed by the Project Manager.

- @ *Wet* the deck forms *and approach slab grade shall be dry* before placing the concrete. Concrete shall be adequately vibrated to encase the lower bars of the reinforcing mat where these are near the deck form.

Special attention shall be given to finishing the riding surface on the bridge floors. Specifications Section 706.03, 710.03, and 711.03 explains concrete bridge floor finish.

It has been the policy to permit the contractor to use mechanical finishing machines of an approved type whether or not they are required by the plans or special provisions.

Method of Finish - When the hand method described in Section 704 is employed, the concrete surface shall be struck off with a strike board which conforms to the cross section shown in the plans. If this is pulled by hand, care shall be taken not to displace the reinforcing steel by the workmen doing the pulling. A small air winch anchored to a girder outside of the day's pour will pull the strike off at a slow, uniform rate, giving a truer surface with no displacement of the reinforcing steel. The strike board shall be operated with a combined longitudinal and transverse motion, always carrying a small roll of concrete in front of the cutting edge. The strike off shall be pulled a sufficient number of times to properly distribute the concrete. A longitudinal float generally is required and is described in *SSHC Section 704*. The longitudinal float shall be lapped 1/2 its length when moved to a new position and shall be operated across the surface a sufficient number of times to produce a uniform, smooth riding surface. Occasionally during the finishing operation, conditions may require the use of the long-handled transverse float, which require extreme care in its use to preserve the desired cross-section and a smooth riding surface.

Regardless of whether hand 3m (10 foot) machine finishing methods are used, the floor surface shall be tested for trueness with a straightedge. The bridge contractor is required to furnish a 3 m master straightedge for use in trueing and checking the working straightedges.

@ ~~The contractor may belt the surface if he/she so desires, but this is not required by the specifications. However, a A burlap drag is required and this operation should be performed as soon as the surface will support the drag. A tined surface is also required by the specifications.~~

Templates used to support the strike off should be in short sections (3 m to 4 m) (10 to 14 ft) so they may be removed as the finishing operation advances, allowing the final floating and surface testing to take place, and the wet burlap to be applied immediately.

@ ~~Starts as early as 5:00 a.m. are helpful if they allow completion of the work before the extreme heat of the day. Decks should be cast after the afternoon high temperature is reached. (In summer, this can be as late as 7:00 p.m.)~~ Protection of the aggregates from the sun is also helpful.

When mechanical self-propelled finishing machines are used, they shall be capable of obtaining a finish equal to or better than that obtained by the hand method. The screeds of the finishing machine should be set to the exact cross section shown in the plans.

Elevation shots will be required for the setting of the riding rails. The usual procedure is to give a fill to grade at the locations where girder shots were taken. The contractor will then set the rail to the correct height to accommodate the machine. An "eyeball" check of the rail for smoothness should always be made. On girder bridges the rail will follow a line that should be smooth after the girders have deflected from the dead load. Correct elevations of the rail can be checked by measuring the distance from the screed to the formwork which should give the correct thickness of slab.

Careful attention should be given to the depth of cover over the top steel. With the extensive use of salt, the service life of the steel is reduced if the concrete cover is less than that shown in the plan. (The finishing machine must be dry run to check the minimum clearance of the reinforcing steel and to check the grade of the expansion devices.)

If the finishing machine is used when there is a transition between regular crown and full superelevation, a system should be worked out well in advance of pouring to insure that the screed can be changed rapidly and correctly at intermediate points of the transition. This is important in order that there are no long delays caused by screed adjustments while pouring the transition.

@ Retarders - Retarders may be used to delay the setting time of the bridge floor concrete. If the temperature is 15°C (60°F) and rising, retarders must be used. *A good goal is to be finishing at the next pier before the concrete is setting-up at the previous pier. Acceptable retarders are Pozzolith 300R and Doratard-17. Water reducing admixtures like WRDA-82, Procrete-N, and Masterpave-N are not acceptable retarders.*

When a retarder is required the rate of placing concrete for any positive moment section will be within two-thirds of the initial setting up time of the retarded concrete after the previous negative moment section has been poured. For example, if the initial set takes place in 6 hours, the pouring of a positive moment section must be completed within 4 hours after the completion of the previous negative moment section. This same procedure should be required regardless of whether or not retarders are used.

Calibration of Concrete Proportioning Equipment - Calibration of this equipment should be as described in the National Ready Mixed Concrete Associations' Quality Control Manual.

## Field Documentation

The temperature of concrete should be taken as soon as concrete is placed. It should be taken when the first load is placed. Additional checking is warranted if the temperature is running at or near maximum. Air temperature should also be taken about the same time as the concrete temperature.

### **PLACEMENT METHODS (PUMPING, BELTING, AND CRANE BUCKET) (SSHC Subsection 704.03)**

Much concern has been expressed about the method of concrete placement because of lost entrained air. Rough handling of plastic concrete during placement has, at times, reduced entrained air to less than 2% not to mention potential segregation problems. While testing at the point of placement "should" identify such problems, varying placement conditions during the pour can affect concrete conditions significantly.

General conditions which must be avoided, or at least severely minimized, are as follows. If one of the following cannot be avoided, at least be aware of the condition, and be sure to conduct additional testing should any of the conditions present themselves.

#### **Crane and Bucket**

In the past it was felt the crane and bucket placement method did not adversely affect concrete. This is now in question when viewed from loss of air and potential segregation. Therefore, this method will now also require testing at the placement location, if practical.

#### **Points-to-Watch For**

- Free fall of unrestrained concrete shall not exceed 1.5 m (5 ft). ~~If the distance is exceeded: (1) reduce the pour depth, (2) Avoid exceeding a 5-ft. free fall by removing~~ remove a section of form work for intermediate placement ~~(3)~~ or by use of a tremie.
- Discharge from the bucket must be controllable.
- Cross section of the drop chute should allow it to be inserted into the form work without interfering with reinforcing steel.

#### **Belt Placement**

Belt equipment is typically used to convey concrete to a: (1) lower, (2) horizontal, or (3) somewhat higher level.

#### **Points-to-Watch For**

- Keep the number and distance of drops between belts to an absolute minimum. Drops tend to encourage segregation and reduce entrained air.
- As belt conveyors are removed from the line (i.e., as on deck pours), recheck the "as placed" air content.
- Be sure all mortar is being removed at the discharge. (No mortar should be on the return belt.)

4. Placement of 0.6 m (2 ft) of flowable mortar.

**Joints (SSHC Subsection 704.03)**

The location and dimensions for construction joints will generally be shown on the plans.

In cases where the pour is larger than can be accomplished at one time, or for some other reason it is necessary to make a construction joint not shown on the plans, approval should come from the Construction Engineer.

When an emergency arises, construction joints shall be placed as directed by the Project Manager. If there is some doubt as to the proper location of the joint, the District Construction Engineer should be contacted.

Construction joints shall be paid for as outlined in SSHC 704.04.

Where it is necessary to transfer shear, shear keys or inclined reinforcement shall be used. It should be pointed out that in practically all cases, shear transfer is essential and therefore shear keys or inclined reinforcement will usually be required. When inclined reinforcement is used as a means of shear transfer No. 5 bars at 300 mm (1 foot) centers should be considered a minimum. The angle of inclination should be approximately 15 degrees (~~60°F~~) from the direction of shear and the length of bar should be at least 685 mm (2'-3") in order that 20 bar diameters can be placed in both sections of the pour.

@

Shear keys should be formed with beveled strips or boards at right angles to the direction of shear. Typical dimensions for a shear key are shown in the following sketch.

If the volume of concrete culvert pour is greater than can be placed in a normal day's operation, or in case of emergency, construction joints located in accordance with the details shown in the drawing "Construction Joints for Box Culverts" may be constructed. Construction joints between roadway shoulder lines are not shown in this drawing since they are not to be so constructed unless authorized by the Construction Engineer.

Construction joints in box culverts should be located as follows: Vertical floor joints, wall joints and top slab joints should be constructed in accordance with the sketches in this article and should be staggered by approximately 1.0 m (3 ft). When the walls and top slab are placed simultaneously, the top slab should be stopped and jointed approximately 1.0 m (3 ft) before ending the wall. (Refer to sketch "Construction Joint for Box Culverts".)

**Preformed Neoprene Joints**

Preformed neoprene expansion joints are used on a large number of bridges.

A. Inspection Checklist

Neoprene cellular joints, if properly installed, provide a leak-proof joint capable of functioning within expansion limits of the bridge. To insure that a joint will function properly, there are a number of precautions that should be noted regarding the installation of this type of joint. Precautions:

1. A neoprene seal can be placed in two positions, one correct and one incorrect. Make sure that the seal is not installed upside down or sideways.



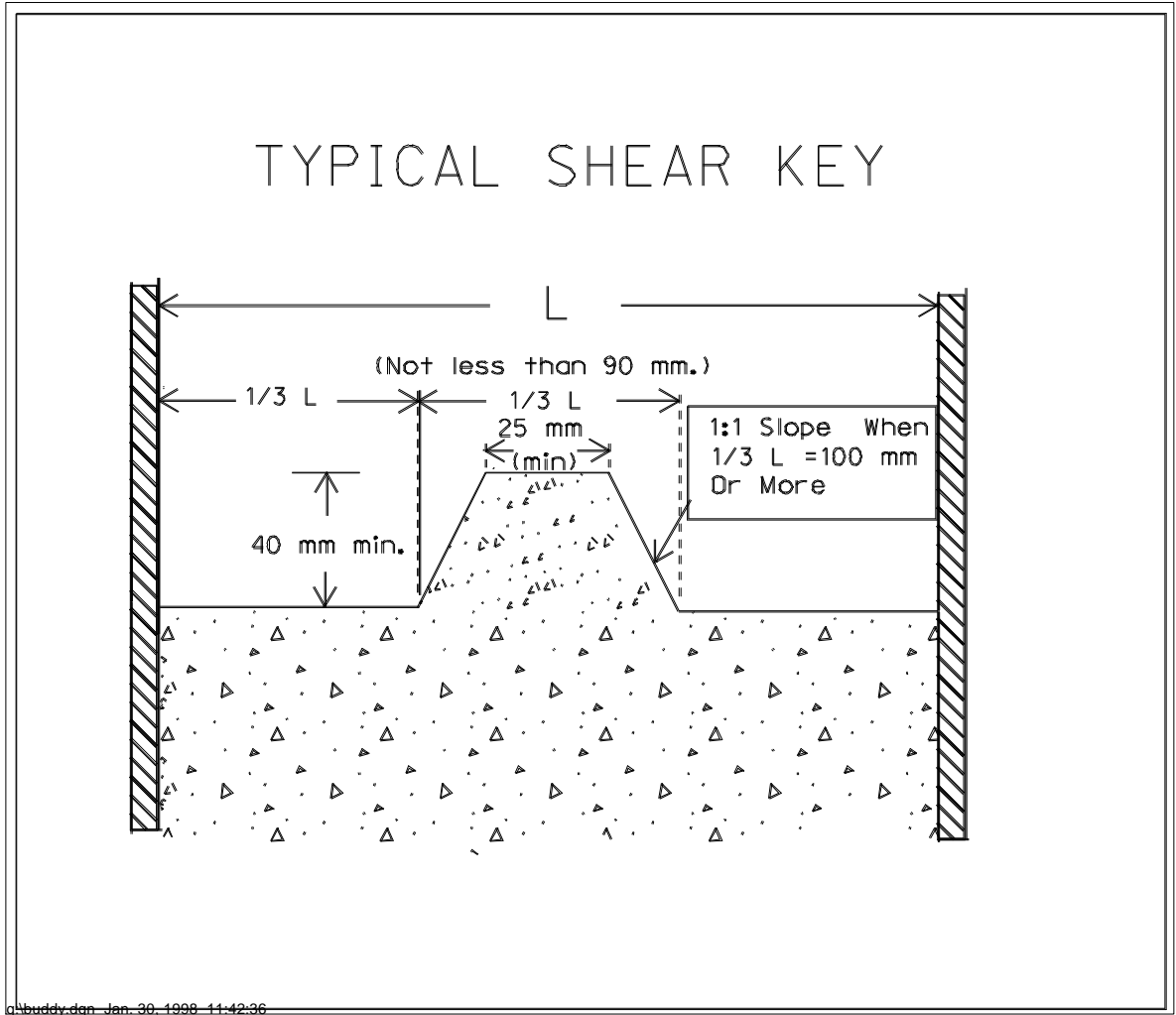

- @ [The side slopes of the key will be less than one to one until the widest dimension of the key reaches 100 mm (4 inches).]
- @ Following is a sketch showing the important features of a horizontal construction joint.

2. Position of the 13 x 6 mm (1/2 x 1/4 inch) keeper bars on vertical face of the expansion plate angles has to be consistent with the recommendations of the manufacturer of the neoprene seal. The depth that a seal is set varies greatly with the different manufacturers.
3. The neoprene seal has to be installed so bottom of the seal touches top of the 13 x 6 mm (1/2 x 1/4 inch) keeper bars, but should not be forced past the keeper bars.
4. Make sure expansion opening between angles of the expansion device are consistent with the expansion setting shown on design plans and that the same expansion opening is maintained from gutter to gutter.
5. The neoprene seal must project beyond the outside edge of slab as shown on the plans.

B. Summary

When uncertain as to which side of the seal is top, or when the position of keeper bars is in question, the contractor must be required to submit drawings prepared by the manufacturer which indicate correct position of installation.

**Curing Concrete**

@ The structure inspector should give careful attention to the curing, since proper curing is essential to good quality concrete. ~~It is important, that when a "wet" burlap cure is employed, the burlap be kept wet to insure proper curing. This is particularly important when weather conditions such as wind, temperature, and humidity make it especially difficult to keep the burlap wet.~~

@ *When the evaporation rate exceeds 0.15 lb/sf/hr, the contractor must either fog the entire deck while placing the concrete; cover the concrete with wet burlap 1 1/2 hours after the concrete leaves the truck; or take some action which will lower the evaporation rate on the entire deck below the 0.15 lb/sf/hr limit.*

@ ~~The Specifications require that bridge decks be cured by the application of any one of three different liquid curing compounds, which is followed by covering with either burlap or a plastic cover. The inspector is cautioned that windy conditions make the application of the plastic cover difficult and extra effort may be required of the contractor to securely anchor these covers.~~

@ *Applying wet burlap as soon as possible is essential – limited removal of tining is acceptable.*

**Concreting in Cold Weather (SSHC Subsections 704.03 and 1002.02)**

As colder weather approaches each fall, the Department experiences a series of problems connected with concrete construction in cold weather. The first indication of the problem usually shows up as a low test result on a 7 day cylinder. At that stage, it is not known if the problem is an improperly fabricated cylinder. A cylinder which has been exposed to colder

## 706.04 Barrier Rails

### Fixed Form Jersey & Retrofit Rail

Before cast-in-place barrier rail is constructed on the existing bridge curb section, *SSHC Subsection 704.03* requires that old concrete which is to be in contact with the new concrete be cleaned of all laitance (loose particles of concrete, dirt, or other foreign materials).

Structurally, the existing curb surface need not be roughened, but must be clean. To assure a clean surface and to obtain maximum bond at the interface, sandblasting the old curb surface shall be required. Other methods of cleaning may be approved by the Project Manager.

Surface preparation, such as sandblasting, should be completed prior to setting the epoxy coated dowels.

When retrofit is part of a deck overlay, the contractor may request permission to place the finish machine on the retrofit rail. Construction's policy will be:

- A minimum cure time of at least 48 hours prior to placing the mass of a finish machine on the rail, AND
- Finish machine rail support feet must be spaced less than 550 mm (1'-9") apart.

If these conditions are unacceptable to the contractor, a minimum cure time of 72 hours will be required. After 72 hours there are no special conditions for placing a finishing machine on the barrier rail.

### SLIP FORM BARRIER RAIL

Slip form rails have at times displayed transverse cracks, longitudinal cracks, reinforcing steel shadows, and nonuniformity of top elevations. Consideration of the following construction problems and solutions will help to eliminate problems:

#### Longitudinal Cracks

@ ~~A tendency to develop Longitudinal cracks on an inside face about 75 mm (3 inches) down from the top is thought to be the result of rail tending to slump to the outside, and vertical cracks near posts can be prevented with proper construction techniques. (Consolidate uniformly, obtain proper rebar clearance and wet cure.)~~

## 706.05 METHOD OF MEASUREMENT

@ The cubic ~~meters~~ yards of concrete for structures of varying sizes are computed from dimensions shown in the plans and placed in tables in the plans. All structures using the same type of concrete are lumped together.

**707.00 BRIDGE DECKS AND OVERLAYS (SSHC Sections 710 and 711)****707.01 DESCRIPTION**

The concrete bridge floor is the wearing surface of the bridge superstructure and is commonly referred to as the bridge "deck". This work consists of forming, reinforcing, and placing concrete to the lines, grades, and typical cross sections shown in the plans.

**707.02 MATERIAL REQUIREMENTS****Concrete****~~Concrete Mobile Mixers (used mainly with High Density Low Slump Concrete)~~**

~~Continuous concrete mobile mixers are equipped with a recording water meter, as well as a cement meter register. It is possible to determine, within a reasonable degree of accuracy, the water/cement ratio of the concrete mix. Since moisture tests to determine the water in the aggregates are not routinely performed, a precise water/cement ratio cannot be made. It will provide relative data with regard to the mix that has not been obtainable.~~

@ ~~Data from bridge deck repair projects of the last several seasons have been reviewed. The evaluation indicates that the actual water/cement ratios are very close to the design, or intended, water/cement ratio. Therefore, no maximum or limiting water/cement ratio specification for the low slump, bridge repair concrete is recommended. The water/cement ratio of low slump concrete need not be determined for bridge overlay surface courses. The witnessing and documentation of the dilution procedure of the air and water reducing admixtures must be observed.~~

~~Existing specifications presently allow a mobile concrete mixer to be used for certain structural concrete repair, if part of a bridge deck repair project. For these, and any other concrete construction for which the Project Manager might authorize this equipment a water/cement ratio limit is specified. Thus, the water/cement ratio must be checked, and documented, for compliance when low slump concrete is not being produced.~~

**Frequency of Checks**

~~Concrete mobile mixers have cement and water meters that are continuously recording, and a water/cement ratio check may be made at any interval, e.g. hourly, half days, or at the end of a placement. A minimum of one check per day's placement should be made and documented.~~

**Density Testing**

Durable, low maintenance bridge decks require impermeable (very dense) concrete. Therefore, checking density during placement is an essential part of deck surfacing and overlay inspection. Test frequencies for determining the density of bridge deck surfacing and overlays are listed in *SSHC Subsection 711.04*. A test should be taken at 1.5 m (5 ft), 3 m (10 ft), 4.5 m (15 ft), and every 15 m (50 ft) thereafter per placement width per bridge. Density tests will not be required for overlaying approach paving areas.

*SSHC Section 704.* The longitudinal float shall be lapped 1/2 its length when moved to a new position and shall be operated across the surface a sufficient number of times to produce a uniform, smooth riding surface. Occasionally during the finishing operation, conditions may require the use of the long-handled transverse float, which require extreme care in its use to preserve the desired cross-section and a smooth riding surface.

Regardless of whether hand or machine finishing methods are used, the floor surface shall be tested for trueness with a 3 m (10 ft) straightedge. The bridge contractor is required to furnish a 3 m (10 ft) master straightedge for use in trueing and checking the working straightedges.

~~The contractor may belt the surface if he/she so desires, but this is not required by the specifications. However, a burlap drag is required and this operation should be performed as soon as the surface will support the drag. A tined surface is required by the specifications.~~

@ ~~Templates used to support the strike off should be in short sections (3 m to 4m) (10-13 ft) so they may be removed as the finishing operation advances, allowing the final floating and surface testing to take place, and the wet burlap to be applied immediately. Starts as early as 5:00 a.m. are helpful if they allow completion of the work before the extreme heat of the day. Protection of the aggregates from the sun is also helpful.~~

~~When mechanical self-propelled finishing machines are used, they shall be capable of obtaining a finish equal to or better than that obtained by the hand method. The screeds of the finishing machine should be set to the exact cross section shown in the plans. Elevation shots will be required for the setting of the riding rails. The usual procedure is to give a fill to grade at the locations where girder shots were taken. The contractor will then set the rail to the correct height to accommodate the machine. An "eyeball" check of the rail for smoothness should always be made. On girder bridges, the rail will follow a line that should be smooth after the girders have deflected from the dead load. Correct elevations of the rail can be checked by measuring the distance from the screed to the formwork which should give the correct thickness of slab.~~

~~Careful attention should be given to the depth of cover over the top steel. With the extensive use of salt, the service life of the steel is reduced if the concrete cover is less than that shown in the plan. (The finishing machine must be dry run to check the minimum clearance of the reinforcing steel and to check the grade of the expansion devices.)~~

~~If the finishing machine is used when there is a transition between regular crown and full superelevation, a system should be worked out well in advance of pouring to insure that the screed can be changed rapidly and correctly at intermediate points of the transition. This is important in order that there are no long delays caused by screed adjustments while pouring the transition.~~

~~Retarders – Retarders may be used to delay the setting time of the bridge floor concrete. If the temperature is 15°C (65°F) and rising, retarders must be used.~~

~~When a retarder is required, the rate of placing concrete for any positive moment section will be within two thirds of the initial setting up time of the retarded concrete after the previous negative moment section has been poured. For example, if the initial set takes place in 6 hours, the pouring of a positive moment section must be completed within 4~~

~~hours after the completion of the previous negative moment section. This same procedure should be required regardless of whether or not retarders are used.~~

@

~~Calibration of Concrete Proportioning Equipment – Calibration of this equipment should be as described in the National Ready Mixed Concrete Association’s Quality Control Manual.~~

### **Deck Overlay Preparation**

Securing an adequate bond at the interface of the existing prepared deck surface and proposed overlay course is essential in obtaining a durable and maintenance free bridge deck system. General surface preparation requires milling, shotblasting, and/or sandblasting depending on the surface condition or amount of existing surface material to be removed. Any reinforcing bar which is exposed must be sandblasted to remove all rust contaminants, and unsound concrete. Also, prior to placing the grout the surface must receive an air blast to remove dust and other foreign particles from the prepared surface.

@

The surface, once cleaned, must remain clean until the grout and concrete is placed. ~~unless silica fume concrete is used.~~ There have been cases where the prepared deck surface has become contaminated during the decking operations by concentrated traffic of vehicles transporting the concrete. This is especially true when the skid-steer type loaders are used to transport mix. The deck surface is contaminated by the abrasive action between the concrete surface and the rubber tires, and also from oil and other foreign material tracked in from off the bridge. Contamination can be recognized by discoloration or oil on the deck surface. Contamination is especially noticeable in the wheel paths used by the vehicles.

Core specimens taken and tested for bond strength from areas as mentioned above showed a marked decrease in bond strength between the interfaces.

To prevent the cleaned deck surface from being contaminated by traffic, the contractor shall cover any prepared surface with sheets of plywood, multiple layers of plastic, or other suitable material. To ensure a clean surface prior to placement of the overlay system, areas which become contaminated shall be resandblasted followed by an air blast.

### **Class I Floor Repair (SSHC Sections 710 and 711)**

Follow guidance in SSHC Subsections 710.04, para. 1 and 711.04, para. 1.

#### **Work on Adjacent Lanes**

*SSHC Section 423* prescribes traffic provisions when traffic is present.

#### Maximum Air Temperature

@

No continuous placement is to be attempted when temperature forecast is above 30°C (85 86°F).

#### Concrete Temperature

Working time of concrete varies with the temperature of concrete, and concrete temperature varies with the temperature of different materials used in the mix. In order to determine the dosage rate of retarder, an estimate of the mix temperature must be made. The following are suggested estimating methods:

- The temperature of concrete from previous placements could be taken.
- If a ready mix producer is placing concrete the day before a deck placement, this concrete could be checked for concrete temperature.

Regardless of the method used, make the best estimate of what the concrete temperature will be, probably during the warmest part of the day and go with it. Remember, concrete shall not be placed in new decks if the concrete temperature is above 30°C (85°F).

### Use of Finishing Machine (*SSHC Subsections 710.03 and 711.03*)

The finishing machine shall be approved before use. Care must be taken to adjust the screeds to proper crown. Support rails must extend beyond the bridge at both ends at proper grade and sufficient distance to accommodate the machine. This permits finishing to begin promptly at the start of the run and also permits the required straightening to proceed on schedule at the end of the run.

### Straightedging

Following the finishing machine, straightedging should be completed to check for longitudinal smoothness. Straightedges, 3 m (10 ft) in length, need to be operated parallel to centerline of roadway. Each pass should overlap the previous one by a half length. If bull-floating (mopping) is needed to close up the surface, it should always be followed by straightedging.

### Tining (Transverse Grooving)

@ After straightedging, and as soon as practical following finishing, the entire traffic surface, except areas within approximately 600 mm (2 ft) from the curbs, shall be given a suitable tining *with corrugated bull float*.

@ *Tine all bridge decks where posted speed limit will be 40 mph or greater, except for county road bridges 30 m (100 feet) or less in length that have gravel approaches and no plans exist for future hard surfacing.*

*On bridge decks, stop the tining 600 mm (2 ft) from the face of the bridge curb.*

**Do not overlap the grooving.**

### Retarders

*SSHC Subsections 710.01 and 711.01* prescribes how to use admixtures.

### Adequate Labor Force

At preplacement meetings talk about and, before starting a placement be sure the contractor has:

- Proper and adequate materials to protect the placement.
- Adequate numbers of sufficiently skilled laborers available.
- Proper tools on the job.
- Arranged for the rate of delivery of concrete to make the placement operation efficient.

20 cubic meters (25 cy) per hour should be a minimum, depending on the quantity of concrete to be placed. Any method of delivery to the deck should be checked to see that rate of placement can be such that finishing operations can proceed at a steady pace, with final finishing completed before the concrete starts its initial set.

### Curing

@ ~~Curing operations are extremely important. Immediately after final finishing, the area finished shall be covered with wet burlap. Exposed reinforcing steel for the barrier rail shall be protected with a suitable covering to prevent contamination prior to placing the wet burlap. The Bridge Deck Curing Special Provision defines how to cure the deck.~~

@ ~~The surface must be covered with wet burlap as soon as possible. (Slight surface marring and removal of tining is acceptable.) without marring the surface. Burlap must be wet before placing. In hot dry weather, it is better to be a little early than late with burlap cover. The contractor does have the option after 24 hours to cover concrete with plastic for the remaining 48 hours.~~

@ ~~Since shrinkage cracks are due to rapid loss of surface moisture, mix water before the concrete has attained adequate strength, it is imperative that curing protection be initiated before much evaporation can occur. (other than free surface water).~~

### Ways to Avoid Deck Cracks

- @
1. *Verify falsework is stable.*
    - *Temporary piles need to have significant bearing – practical refusal is best.*
    - *Wood crush needs to be minimized. Avoid gaps between layers of timbers – be careful to shim the entire length of support timbers.*
  2. *Avoid unnecessary vibrations.*
    - *Use shooflys where possible to keep traffic away from the bridge.*
    - *Do not rest falsework on active bridge during phased construction unless there is no other alternative.*
    - *However, when it comes to intentional consolidation – the contractor should be very careful to establish a fix pattern for vibration and make sure it is achieved along the entire length of the deck and approaches.*
  3. *Check the temperature of the concrete as it arrives on site. It should not be greater than 86°F.*
  4. *Check the slump and if the slump is less than 3.5 inches, confirm that the mix is not too dry – especially if retarders or water reducers are used. Low slump measurements are a good indicator that mix is too dry especially on hot days. Also, with a low slump, it will be hard to get the mix around and in between rebars and tining with the bull float is much more difficult.*
  5. *Verify camber on girders is correct.*
  6. *Avoid skewed construction of approach sections. If there must be a skew, limit it to 20 degrees. If skew is above 20 degrees, then reinforce the area near the obtuse angles because the stress is significantly increased in this region.*
  7. *Cover the concrete with saturated wet burlap 1 ½ hours after the concrete leaves the truck or pump chute.*



8. *Start casting the deck in the evening – waiting until the outside air temperature begins to drop.*
9. *Check the outside air temperature during casting. It should be less than 86°F.*
10. *If the evaporation rate during casting exceeds .15 lbs/sf/hr, then fogging as prescribed in the Nebraska Fogging Special Provision will replace the evaporating water, keep the deck cool, and slow the setting time.*

### Cold Weather Placement

On account of the high incidence of shrinkage cracks due to artificial heat during the protection period, no bridge floors will be constructed during cold weather except with the special written permission of the Construction Division.

### Floor Drains

Check floor drain locations against floor grades to be sure deck surface will drain. Adjustments of drain height may be advantageous on every flat grade surface. Also, at this time, study the discharge area from the floor drain for potential damage to features under the structure such as shoulders, railroads, or berm slopes. Major problems foreseen should be brought to the attention of the Construction Division.

### Installation of Joints (*SSHC Subsection 704.03*)

#### Reinforcement

Reinforcement must be accurately placed and rigidly fastened. If cages are not rigid and braced diagonally in both transverse and longitudinal directions, problems can occur. The remedy:

- Recommended Procedure:

Epoxy coated smooth bar, about 6 mm (1/4 inch) in diameter can be placed diagonally from the top of a leading cage to the bottom of the second trailing cage. (Description is referenced to direction of paver's travel.)

- Alternate Procedure:

Welding of diagonal braces to provide longitudinal rigidity is possible, but material would need to be epoxy coated and repair of weld location is necessary.

### **Reinforcement Bar Cover**

Reinforcement bar cover has contributed to shadow effect. This occurs when reinforcing cage is not rigid or has only a minimum of cover and too much vibration was used. The remedy:

- Increase bar cover to 65 mm (2 ½ inches) from minimum of 50 mm (2 inches).
- Maintain uniformity of bar cover.
- Build in rigidity to the reinforcing bar cage by placing diagonal braces as described above.
- Reduce slump and do not over vibrate the concrete.
- Require a dry run to check alignment and uniform spacing between the edge of the mule and rebar cage.

### **Shadowing**

Shadowing occurs when slip forming a radius because of nonuniform form pressures inside the mule. The problem manifests as repetitious surface bumps, not depressions as one might think. This problem is inherent with slipforming a radius and is especially noticeable as the radius becomes smaller. In order to minimize shadowing effects, the contractor needs to have finishers work out the bumps by hand.

**NOTE:** To enhance the ability to hand finish slipped rail, CONFILM is recommended. CONFILM is a Master Builders product and should be used per manufacturer's recommendations.

@

### **Smoothness of Bridge Decks**

#### **Checklist**

The following items should be checked and procedures followed prior to, during, and after the overlay is placed to insure a smooth riding deck surface:

- Guide rails are used to support and guide the finishing machine. Check for rail deflection during passage of finish machine. Any vertical or horizontal movement could compromise smoothness and rideability. Request that the contractor readjust anchor legs and/or tie-downs.

- Check that all propulsion and control equipment are fully operational prior to placing concrete. The contractor shall traverse the finishing machine over the entire length of section to be placed. This not only serves to verify that equipment and control systems are functioning properly, but also provides a check to assure that screeds are adjusted for proper crown and height above existing surface.
- Sufficient materials (water, cement aggregate, and admixtures) are available on site to complete the intended placement in a continuous operation.
- The contractor may have to limit size of placement or provide additional mixers (HD-LS only).
  1. If a mobile mixer is not large enough to provide adequate volume for the placement, or
  2. If there is no provision for recharging.
- Ensure that adequate number of vehicles are available at the work site to transport mix from mixer to the placement area at a volume necessary to provide a uniform rate of forward progress. Any equipment working on the deck should be checked for oil and hydraulic fluid leaks.
- Contractor must provide sufficient, trained personnel to carry out the various phases of deck placement. Timeliness is of utmost importance during placement operations. Be sure specialized crafts, such as finishers, are adequately represented and preferably have only one task during the placement.
- Check concrete for smoothness with the 3 m (10 ft) straightedge. The straightedge should be placed on the surface from a vertical position, not pushed over the surface. Irregularities can be detected by comparing deck surface with a straightedge. Irregularities noted at this time should be corrected.

### **Cast-In-Place (Retrofit) Barrier Rail**

This work is routinely combined with a deck repair project and includes an overlay. Often contractors will place the new rail prior to placing overlay. In these situations, the contractor intends to place the finish machine's rail on top of the new barrier rail. Question: How long must the new rail cure before allowing the deck finishing machine to be placed on it?

- 48 hours must expire prior to placing the weight of a finishing machine on the rail.
- Rail supports (legs) must be placed at a spacing of no greater than 500 mm (18 inches).
- Rail supports and rail cannot be placed until the surface has sufficiently cured to prevent scuffing and/or marring.
- Care must be taken to prevent damage to the face or back of the barrier rail.

If above conditions are not acceptable to the contractor, an additional 36-hour cure time will be required as per *SSHC Subsection 711.04*.

@ (Moved rest of this sheet to page 418)

The wing walls and exterior surfaces of the barrel may be cured by any method specified in *SSHC Subsection 704.03*.

@ (This page moved to page 410)

### **Simultaneous Casting of Deck and Approach Slabs**

@

*Casting the approach slabs and the deck simultaneously creates a smoother transition and ride. However, to avoid maintenance and to preserve the integrity of the deck and the approach slabs, a metal bond breaker should be placed over the abutment across the entire width and depth of the deck. This will ensure that a random crack does not occur before the joint can be cut.*

*The rail that the finishing machine rides on must be uniformly rigid. Unfortunately, where the rail passes over the grade beam and abutment, the rail is frequently more rigid than either side of these substructures. This can cause a dip either side of the abutment and the grade beam, which can result in a “bump” over the abutment, and grade beam.*

*Another problem can result when the deck overhangs the outside girder. Typically, the deck forms are supported by outrigger jacks braced against the outside girder. The weight of the concrete and the finishing machine can momentarily bend the outside girder as the placing operation progresses. Temporary construction braces (usually wood blocks) between all girders can prevent girder movement.*

### **Surface Checking (Not in Spec)**

A 3 m (10 ft) straightedge surface check shall be conducted on all bridges and deck overlays not covered by the Smoothness Specification. Surface areas inaccessible to profilometer shall also be checked.

On some projects only one wheel path may be included in the placement width. For price adjustment or incentive pay, only the portion within the traveled lane shall apply. Variable width sections for on and off ramps, which are outside the through traveled lane, will be checked with the surface checker.

### **Test Procedure for Smoothness**

A Special Provision entitled “Bridge Deck and Approach Slab Smoothness” will usually be included in the contract proposal. This Provision deals with the method of testing for smoothness and the method for correcting surfaces outside of the smoothness limits. The contractor is responsible for scheduling the testing, which will be performed by Materials and Tests Division personnel. The contractor must give the Project Manager seven days notice prior to the date he requests that testing be done. The Project Manager shall contact the Materials and Tests Division and arrange for testing on the requested date.

### **Evaluation**

Materials and Tests Division will furnish a profile index to the contractor within 72 hours of the completion of the tests.

### Surface Correction

Corrective work shall be done in the presence of the Engineer with a diamond bladed grinder at least one meter wide. Grinding residue must be controlled. After the deck is ground, a second test will be made to determine if the deck now meets the smoothness requirements. This second test will also be performed by Materials and Tests Personnel and it is anticipated they will be on-site at the time of grinding, in order that they may perform the retest while the grinding equipment is on-site.

### Acceptance

Materials and Tests personnel will notify the Project Manager whether or not the corrective work has resulted in an acceptable deck surface. If grinding cannot correct the surface profile, the Specification requires removal and an overlay with high-density low slump concrete.

## **708.00**      **HAND RAILS** (*SSHC Section 716*)

### **708.01**      **DESCRIPTION**

This work shall consist of furnishing and erecting all steel or ornamental handrail and all miscellaneous hardware such as anchor bolts, capacity plates, and splices.

- County bridges usually only get one coat.
- New state structures usually get two coats.
- Repainting an existing structure usually means adding a third coat.

The Project Manager or inspector should check the dry film thickness of the shop and field coats of paint applied on structural steel in accordance with the following instructions:

Shop Coat - The shop coat of paint may or may not have been checked in the fabricator's shop; nevertheless the shop coat should always be checked in the field, and any deficiency in paint film thickness corrected, before the second coat is started. When the dry film thickness of the shop coat is found to be inadequate, the Materials and Tests Engineer should be notified in order that the particular fabricator involved may be made aware of the situation.

@ Second and Third Coats - Checking the thickness of the second and third coat with the magnetic gauge is accomplished by measuring the cumulative thickness of the first coat (or shop coat) and the additional coats. The dry film thickness of the second coat should always be checked and any deficiency in paint film thickness corrected before the third coat is started. Any deficiency in paint film thickness must be corrected before the work can be considered complete and consideration of acceptance given.

The equipment used to check the dry film paint thickness is called a magnetic dry film thickness gauge. One or two of these gauges are being furnished to each District Office for use in the District in checking the painting of steel structures. These gauges are expensive, delicate instruments and must be carefully handled and always kept in the carrying case when not in use. The procedure for using the gauge is as follows:

1. Turn dial to maximum reading.
2. Place pole on the surface to be measured.
3. Be sure the magnetic contact is touching the painted surface.
4. Slowly and as continuously as possible, rotate the dial clockwise until magnetic contact breaks. A click will be heard when the pin breaks contact. At this point the coating thickness can be read on the dial indicator. The reading will remain on the dial when the gauge is removed from the surface being checked. The gauge can also be held in any position to take a reading. The magnetic gauge reads directly in mils. A reading of 2 on the dial indicates that the thickness of the paint film is 2 mils or .002 inch.

The frequency of testing for paint thickness should be as follows:

1. Girders - Each line of girders should be checked at a maximum interval of 15 m (200 ft) and at each check point, 3 or 4 tests should be made. For example, on a 60 m (50 ft) bridge each line of girders should be checked at the abutments and at 3 intermediate points. At each one of these points three or four places should be checked such as a point on the web, a point on each flange, and a point on a stiffener.



**710.00 CONCRETE BOX CULVERTS** (*SSHC Section 717*)

**710.01 DESCRIPTION**

A culvert may be defined as a structure to convey water under a roadway. Concrete box or arch culverts are used when drainage areas are too large for the conventional culvert pipe or when cattle passes under the roadway are desired. These structures are cast-in-place according to standard or special plans under *SSHC Sections 702, 704, 705 and 717*.

**710.02 MATERIAL REQUIREMENTS**

See Section 706.02.

**710.03 CONSTRUCTION METHODS**

General - The concrete placement for box and arch culverts is discussed in Section 706 of this manual. *SSHC Subsection 717.04* further provides that foundation excavations shall be "as dry as practicable before concrete is poured". This requirement recognizes the necessity of an adequate foundation for roadway structures. When the excavation for a footing is completed, the project manager or his/her representative should be contacted for his/her approval of the footing subgrade before any concrete is placed. In the event that unsuitable foundation subgrades are encountered, suitable ones composed of concrete aggregates or a concrete seal course must be constructed (see Subsections 702 and 702 of this manual).

Construction of curtain walls on culvert footings usually is quite a problem because of the difficulty in maintaining the excavation in proper condition while placing concrete.

If material to be excavated is of such nature that neat lines for the curtain wall cannot be maintained, the Project Manager may allow forming and placing the curtain wall to the bottom of the footing. Mud must be prevented from working up into the concrete.

Currently, the plans for box culverts show the backside of the wing battered 3/8" in 12", which results in a varying wall thickness. Contractors may be permitted to construct walls with a uniform thickness, thus eliminating the batter. A plan revision or change order will not be required to effect this change.

@ **Placing Concrete and Form Removal**

**Placing Concrete**

Placing Concrete in Walls and Top Slab. *SSHC Subsection 704.03* states that culvert, sidewalls, and top of slab may be constructed as:

- A monolith unit or,
- Concrete in sidewalls may be placed and allowed to harden before the top slab is placed.

If the contractor chooses to use the hardened concrete method, keyways will have to be installed to anchor the cover slab.

### Removal of Wall Forms

On large culvert jobs, it is a distinct advantage for the contractor to remove wall forms before the top slab has attained sufficient age to remove supporting forms. This will be permitted under the following conditions:

- Vertical forms may be removed as provided in *SSHC Subsection 704.03*.
- Slab forms must be supported independently of the wall forms.
- Vertical supports for the slab forms must be capped with timbers. Longitudinal spacing of supports with 100 x 150 mm (4x6 inch) caps on edge should not exceed 1.4 m (4.5 ft). With 100 x 200 mm (4x8 inch) caps, spacing should not exceed 1.8 m (6 ft). Rows of supports must not be over 1.2 m (4 ft) apart. There must be at least two rows of support, with the outside rows not more than 0.6 m (2 ft) from walls. Variance from the above suggested spacing should be reviewed by the Project Manager.
- Vertical posts shall not be smaller than 100 x 100 mm (4x4 inches), but may be built up of two 50 x 100 mm (2x4 inches) pieces of lumber. Lateral bracing will be required. A vertical clearance of 6 mm (1/4 inch) must be provided between the wall form studs and the slab form joists.

**NOTE:** Lumber may be sized in metrics using actual, not the conventional nominal sizes.

- The slab form must remain in place as provided in *SSHC Subsection 704.03*.
- The interior walls of the culvert must be coated with white pigmented curing compound as provided in *SSHC Subsection 704.03*.

### Flume Reinforcement

Regarding Type I, II, IV, and V Flumes, welded wire fabric reinforcing is now required on the Special Plan C (4341, 4342, 4344, 4345 -- both E & M) for the flume and spillway areas. This wire can be awkward to place and keep in position. Contractors may place **intersecting No. 3 rebar at 12" centers** as an alternative to the welded wire fabric.

**711.00 CONCRETE PIPE CULVERTS** (*SSHC Section 720*)

**711.01 DESCRIPTION**

This work shall consist of furnishing and installing new reinforced concrete culvert pipe (round, pipe-arch and elliptical), reinforced concrete slotted pipe and the relaying of existing reinforced concrete pipe.

**711.02 MATERIAL REQUIREMENTS**

Each section of pipe used should be marked with the fabrication inspector's initial and the class of pipe, when it arrives at the site. The culvert inspector should not permit the laying of any section that does not have these markings. The project manager will receive a copy of the "Report of Shipment of Reinforced Concrete Pipe" (Form DR-420), listing the size, class, length, number of sections of pipe, the inspector's identification mark and stock report number. The inspector will use the information contained in this report to verify approval of reinforced concrete pipe received on the project. The diameter, class, length, number of sections and the pipe identification number shall be recorded in the culvert notebook. Each section of pipe should be examined for damaged ends, cracks and evidence of poor manufacture. All irregularities should be referred to the Project Manager before using of the pipe.

**Ordering Material**

- @ • The contractor is **not permitted to order or deliver** culvert pipe until a "culvert list" listing the correct sizes and lengths of pipe is furnished by the Project Manager. See Subsection 105.07 of this manual for detailed instructions on the field checking of culverts and the preparation and submission of the culvert list.
  
- @ • The Project Manager shall furnish a pipe list for driveway and sewer requirements.

**711.03 CONSTRUCTION METHODS**

**Excavation and Backfilling**

See Section 702 of this manual.

**Installation**

Begin laying concrete pipe at the downstream end of the culvert with the groove or bell portion of each section upstream.

Irrigation culverts shall be constructed of concrete pipe and must have approved gaskets at the joints. These gaskets shall be installed as per the manufacturer's recommendations and standards.

**712.00      CORRUGATED METAL PIPE CULVERTS (SSHC Section 719)**

**712.01      DESCRIPTION**

This work shall consist of furnishing and installing new corrugated galvanized metal pipes and pipe arches and the relaying of existing corrugated metal pipe and pipe arches.

**712.02      MATERIAL REQUIREMENTS**

SSHC Tables 1035.01 & 1036.01 contain the required minimum gage or sheet thickness for the various pipe diameters. The "Materials and Sampling Guide" provides that the necessary tests for acceptance will be handled by the Materials and Tests Division. Material samples need not be taken by project personnel unless a special request is made for samples. The diameter of the pipe and number of sections of pipe covered by each heat number and delivered to each culvert location should be recorded in the culvert notebook. The pipe shipment should be checked against the shipment report and any discrepancy should be reported to the Project Manager. The pipe shipment should also be checked for shipping damage and any damage noted should also be reported to the Project Manager.

**Ordering Material**

**The contractor is not permitted to order or deliver corrugated metal pipe or pipe arches until a "culvert list" listing the correct sizes and lengths of pipe is furnished to him/her by the Project Manager.** Subsection 105.07 of this manual for detailed instructions on the field checking of culverts and the preparation and submission of the culvert list.

**712.03      CONSTRUCTION METHODS**

**Excavating and Backfilling**

Refer to Section 702 of this manual.

**Installation**

**@** The culvert inspector should insist ~~of~~ *on* careful handling of the corrugated metal pipes or pipe arches. Corrugated metal pipes or pipe arches should be lifted and moved with a rope sling or similar device which will not damage the galvanized surfaces of the pipes or pipe arches. The contractor should not be allowed to drag the pipes or pipe arches over abrasive surfaces as this will also damage the galvanized surfaces.

Corrugated metal pipes and pipe arches shall be laid with the inside circumferential laps lapped downstream so that the water will flow over the lap. The pipe shall be rotated so that the longitudinal laps are horizontal. When joining sections of pipe, the connecting bands should be pulled up as tight as possible. The band should be tapped with a wooden mallet as the bolts are tightened. Excessive pressure on the bolts should be avoided to keep from pulling the steel angle loose from the band. A gap of about 25mm (1 inch) should be allowed between the pipe ends being joined, to allow the corrugations on the pipe and band to match. Corrugated metal pipe is not generally used for irrigation structures.



## Lapping of Guardrail

Lapping of rail must be accomplished in a uniform manner. Details shown in the plans will achieve uniformity statewide. However, clarification may be helpful in obtaining this uniformity in specific instances.

Standard road plans indicate guardrail shall normally be lapped in direction of traffic flow. Following this general rule, most installations will be lapped correctly. Standard road plans provide a lapping procedure detail for each type of guardrail installation except:

- On long guardrail installations involving more than one hazard such as a combination of bridges, culverts, high fills, sign truss footings, etc., lap should protect near traffic from being speared by an end of a section of guardrail.
- Where guardrail alignment is curved away from centerline (bridge ends or end sections), lap should protect approach vehicles.

Keep in mind that the basic principle of lapping has to do with favoring the traffic for which the guardrail is being installed.

All laps of rail shall take place at a post. The 16 mm (5/8 inch) x 32 mm (1 ¼ inch) splice bolts at these laps should not have washers.

## END ANCHORAGE

@ To insure that concrete does not become attached to bottom and sides of breakaway end anchorage post a small amount 25 or 50 mm (1 or 2 inch) of soil may be tamped around post bottom or bottom 150 mm (6 inch) of post may be wrapped with expanded polystyrene foam sheets in place as shown on the plans. If steel tubes are used, grease the bottom 300 mm (12 inches) of the wood post *and the* inside of the sleeve generously. This is done so that it would be easy to remove the damaged ones.

Soil removed from all end anchorage holes should be disposed of away from the hole to insure proper installation height.

To remove post a small quantity of diesel fuel can be poured on expanded polystyrene foam. This will dissolve foam for easy removal.

SRT, MELT, and BCT are gating terminals. ET2000, and BEST are energy absorbing terminals.

## BRIDGE CONNECTIONS

Bridge approach section type CD terminal section shall be installed under rail so a vehicle cannot be snagged by the end section. Exception to this is on trailing end of a one-way bridge where Type "J" terminal section shall be installed on outside of rail.

On guardrail attachments to concrete which require a bolt longer than 600 mm (2 ft), 22 mm (7/8 inch) bolt anchors may be grouted into concrete using threaded insert anchors with epoxy.

If a test report is not available for the material being checked, contact the Engineer of PCC and Tests in the NDR Materials and Tests Division at (402) 479-4756 to check on the status on the material in question.

### **1003.03      REPORTING MATERIAL USAGE**

The quantity of white pigmented curing compound and/or hot-pour joint sealer used on a project is to be reported by project personnel using the “Create Usage Report” in the “YCCHP” program.

At the main menu of the “YCCHP” program, after “Select Material” and “Select Manufacturer” have been entered, press the PF9 key (Create Usage Report).

The next screen will show the usage report. The following information is to be completed:

- Lot Number
- Control Number
- Project Number
- Project Location
- Quantity Used (gallons of curing compound or pounds of joint sealer)
- Report By

For information purposes, the quantity of material used on a project can be determined by pressing the PF10 key (Query Usage by Control Number) from the main menu of the “YCCHP” program. After pressing the PF10 key, the next screen will show a blank usage report. Enter the Control Number for the project to determine the quantity of curing compound and/or joint sealer used on the project.

### **@      1003.04      CEMENT CERTIFICATIONS**

*Note 7 in the Materials Sampling Guide, Volume II, requires that the pink copy of the cement certificate of compliance, DR Form 228 or a copy of the mill’s own certification form be mailed to the Materials & Tests Division. However, Materials & Tests does not need the pink copy of the certification mailed to them anymore. The copy at the concrete production facility is enough for Materials & Tests records.*

*The certificate of compliance is needed both for mills that require sampling and those that do not. When a sample is required, normal procedure has been to submit the pink copy with the sample. This is acceptable. For those mills which do not require sampling, please collect and submit the certifications on a routine basis but at a minimum of once each week.*

## DIVISION 1200 -- SITEMANAGER

### 1200.01 INTRODUCTION

SiteManager™ is one of the most powerful software support systems available to transportation agencies. It seamlessly integrates field-based data collection, administration of contract records, contractor payments, project-oriented civil rights monitoring, and materials management. All this is combined with a state-of-the-art, client/server environment and is available to field, project, district, laboratory and central office personnel.

### 1200.02 IMPLEMENTATION SCHEDULE INFORMATIONAL GUIDANCE

@ ~~The Department has begun to use SiteManager. As each District gets their computers and are trained in their use, the Department will shift to complete project management under "SiteManager". The network will interface with the NDR mainframe computer data bases.~~

*We are able to make payments to the contractors from SiteManager.*

*All future contracts which haven't started work yet will be done in SiteManager. For those contracts which have just had one or two estimates generated in CON, the PM's should create a Daily Work Report to generate the equivalent estimate(s) in SMGR in order to catch up and begin payment in SMGR. Any questions on how to do the "catch up" should be directed to the Trainers or the Support Personnel in Lincoln.*

*Those contracts which are almost done and only have one or two estimates to go before the work is complete will probably just finish out in CON.*

*Those contracts which have been underway for sometime but will be continuing through most of the upcoming construction season or longer will be migrated to SMGR. These contracts will be dealt with individually because of the effort involved in migrating. This migration effort will take place over March and April. Someone will be in touch with each of the project managers who have projects that fit into this category.*

### @ 1200.03 GUIDANCE

@ Each lap top that is used for Construction Inspection and management has the SiteManager documentation installed on the hard drive. This is the official source for guidance and use of SiteManager. *In addition, supplemental help files are available on DORSRV81/runtime/how\_to.chm.*



**1200.04 FCAC MEMBERS**

(As of 11-1-97)

**Construction – Central Complex**

Bill Hitzeman	<del>(402) 479-4456</del>	DOR20004
Rhonda DeButts	<del>(402) 479-4760</del>	DOR9026
Paul Dodson	<del>(402) 479-3830</del>	DOR20017
Shirley Daugherty	<del>(402) 479-4459</del>	DOR17001

**District 1**

Larry Winslow	<del>(402) 471-0850</del>	DOR31080
Jim Gross	<del>(402) 471-0850</del>	DOR31009
Darin Brown	<del>(402) 471-0850</del>	DOR31087

**District 2**

Karl Burns	<del>(402) 595-2534</del>	DOR32033
Jodie Domenge	<del>(402) 595-2534</del>	DOR32008
Marvin Lech	<del>(402) 595-2534</del>	DOR32007

**District 3**

Lynette Norman	<del>(402) 370-3474</del>	DOR33006
Steve Trosper	<del>(402) 370-3470</del>	DOR33044
Curt Mueting	<del>(402) 370-3474</del>	DOR33075

**District 4**

Scott Griepenstroh	<del>(308) 385-6265</del>	DOR34078
Terry O'Neel	<del>(308) 385-6265</del>	DOR34008

**District 5**

Russ Frickey	<del>(308) 262-1920</del>	DOR35006
Scott Clinger	<del>(308) 262-1920</del>	DOR35051

**District 6**

Ronda Lewis	<del>(308) 535-8031</del>	DOR36053
Paul Kieper	<del>(308) 535-8031</del>	DOR36121

**District 7**

Jerry Quinn	<del>(308) 995-5397</del>	DOR37013
James Moreau	<del>(308) 995-5397</del>	DOR37014

**District 8**

Mark Kovar	<del>(402) 387-2474</del>	DOR38001
Jay Gustafson	<del>(402) 387-2474</del>	DOR38017
Gene Colfax	<del>(402) 336-2054</del>	DOR38013

**Information Systems – Central Complex**

Steve Brown	<del>(402) 479-3966</del>	DOR10042
Venkatesh Hadli	<del>(402) 479-3826</del>	DOR10118
Jon Ogden	<del>(402) 479-4564</del>	DOR8002

@

**1200.03 SITEMANAGER SUPPORT LIST****System Administration**

Lee Burbach	Information Systems	(402) 479-3982
Shirley Daugherty	Construction Division	(402) 479-4559
Jim Ferguson	Construction Division	(402) 479-4454
Mitch Hendricks	Information Systems	(402) 479-3616
Bill Hitzeman	Construction Division	(402) 479-4456

**District Trainers**

Darin Brown	District 1	(402) 471-0850, Ext. 1087
Jodie Domenge	District 2	(402) 595-2534, Ext. 223
Bill Mainquist	District 3	(402) 370-3470
Terry O'Neel	District 4	(308) 385-6265
Scott Clinger	District 5	(308) 262-1920
Russ Frickey	District 5	(308) 262-1920
Ronda Lewis	District 6	(308) 535-8031
Kelly Doyle	District 7	(308) 345-8490
Linda Jackson	District 8	(402) 376-1126
Rhonda DeButts	Materials & Tests	(402) 479-4760

**Resident Trainers**

Noel Salac	District 1	(402) 471-0850, Ext. 1107
Craig Washburn	District 1	(402) 471-0850, Ext. 1138
Jeff Kisicki	District 1	(402) 471-0850, Ext. 1910
Bill Jasa	District 1	(402) 335-4131
Russ Eltiste	District 1	(402) 335-4131
Mel Kuper	District 1	(402) 729-3489
Bob McClure	District 1	(402) 729-3489
Karl Burns	District 2	(402) 595-2534, Ext. 269
Micky Jacobs	District 2	(402) 727-3292
Gary Mangan	District 2	(402) 595-2534, Ext. 268
Mark Kai	District 3	(402) 375-7071
Lynette Norman	District 3	(402) 370-3474
Lisa Sudbeck	District 3	(402) 254-6552
Lowell Napier	District 3	(402) 564-5751
Lyle Kohmetscher	District 4	(402) 462-4996
W. T. Farber	District 4	(308) 462-1996
Richard Kwiatkowski	District 4	(308) 754-5411
Tom Anderson	District 4	(402) 362-5934
Arlen Zaruba	District 4	(308) 728-5655
Scott Griepenstroh	District 4	(308) 385-6265
Calvin Splattstoesser	District 4	(308) 385-6265

<b>Resident Trainers</b>		
--------------------------	--	--

Duane Katen	District 5	(308) 432-6144
Tony Armer	District 5	(308) 262-1920
Darryl Steinwart	District 5	(308) 632-1429
Kerri Lewandowski	District 6	(308) 535-8031
Bill Teahon	District 6	(308) 872-6733
Duane Collins	District 7	(308) 345-8490
Gene Colfack	District 8	(402) 336-2051
Mike Freeman	District 8	(402) 387-2471
Dean DeButts	Materials & Tests	(402) 479-4809
Chris Dowding	Materials & Tests	(402) 479-4753

- The contractor shall be responsible for the protection and integrity of the stakes after placement. The contractor shall take the necessary measures to achieve this.
- @ • *All Preliminary survey results go to Ken Hartwig, Geodetic Survey Section. Ken checks the data then passes the data onto both Kurt Svoboda, Right-of-Way, and to the Roadway designer responsible for the project.*
  - ◆ *ROW surveys are generally done as part of the Preliminary survey. However, Gene Thomsen does many of the ROW surveys.*
  - ◆ *Hydraulic surveys are also part of the Preliminary survey and the data is provided to Don Jisa, Bridge Hydraulic Section.*
- *The Geodetic Survey Section does Photogrammetric surveys. The Photogrammetry Section plots/maps the survey data.*
- *GPS Pairs are permanent monuments.*
  - ◆ *On each project the Geodetic Survey Section will provide a GPS pair at the beginning, end, and every 2-3 miles along the project.*
  - ◆ *Usually the monuments are offset 500-1,000' left and right of the centerline.*
- *The GPS establishes the state coordinate system.*
  - ◆ *HARN was created in 1995 with the help of a National Geodetic Survey, which established a grid of accurate points across Nebraska based on GPS sightings.*
  - ◆ *Contact the Bridge or Roadway Design Division if you need the coordinates of any point.*
- *Geodetic surveys are expensive.*
  - ◆ *Preliminary surveys are estimated at 200 hours per mile in rural areas ± correction factors.*
  - ◆ *Preliminary surveys are estimated at 800 hours per mile in urban areas ± correction factors.*
  - ◆ *If a contract survey is estimated above in-house time allocations, try to find a way to do the work in-house.*

offset (design) centerlines. See Subsection 105.08, Paragraph XI.A for an explanation of RDS.

However, if the project was designed on the Nebraska program and line shift is shown on the plan, the final cross sections shall be taken using the new centerline. In this case the centerline of the preliminary sections will be shifted by computer to coincide with the final sections.

@ At least two old ground shots shall be taken on each side of each final cross section and indicated by the letters "OG" in the notes. One of these shots should be marked with a "c" to indicate closure. In case one of the "OG" shots is not within the required ~~90 mm (0.3 ft)~~ 150 mm (.5') closure tolerance, the Project Manager shall place the letter "c" beneath the other "OG" shot with better closure. If the two "OG" elevations are approximately parallel to and below the preliminary ground elevation, the one nearer the centerline shall be marked with a "c" and an explanation made of the closure error. If both are punched the contractor will receive credit for dirt not actually excavated.

Helpful Hints:

1. When the RDS system has been used in the design of the earthwork, it is essential the final cross sections be taken using the original survey (pre-lim) line. This line is referred to as the "G" line in this system. Final cross sections taken from any other reference line will require retaking of the final cross sections.
  2. When it becomes necessary to take the final cross sections after completion of the surfacing work, sufficient room shall be left by the note recorder for inserting calculated rod readings. These rod readings will reflect the elevation of the typical grading section shoulder point. ~~(See samples in Construction Manual).~~
  3. Don't use any harder pencil lead than 3H.
  4. When the final earthwork computation listing sheet is returned to the field, the correction notes are to be reviewed thoroughly. All notes indicating further action are to be addressed at the field office.
- @
2. H.I. Data - The H.I. shall be shown on each page of notes near the location of the centerline shots. When one cross section has been taken from two or more H.I.'s, the portion of the section represented by each H.I. shall be clearly indicated.

Project Manager shall check the reduction of all H.I.'s with care. In order to expedite card-punching operations, it is essential that the following details be recorded:

## APPENDIX 1 - NDR FORMS

### GENERAL ADMINISTRATION FORMS

DR 124	Shop Work Order.....	1 - 5
DR 146	Stock Requisition.....	1 - 6
DR 147a	Stock Returned For Credit.....	1 - 7
DR 151	Purchase Order.....	1 - 8
DR 159	Allowable Equipment Inventory Missing (Lost or Stolen) Damage Report..	1 - 9
DR 329	Imprest Inventory Adjustment.....	1 - 10
DR 332	Furniture and Equipment Issue/Transfer Document.....	1 - 11

### CONTRACT ADMINISTRATION FORMS

DR 16	Contract Time Extension Document.....	1 - 13
DR 42	Field Approval of Subcontract Work.....	1 - 14
DR 44	Summary and Distribution of Costs.....	1 - 15
DR 58	Force Account Agreement.....	1 - 16
DR 84	Record of Contractor Payrolls Received.....	1 - 17
@ DR 87	<del>Safety Inspection Checklist.....</del>	<del>1 - 18</del>
DR 90	Flagger Certification.....	1 - 20
DR 91	Notification of Project Completion.....	1 - 21
DR 96	Inspectors Working Day Report.....	1 - 22
DR 98	Report of Labor Compliance Inquiries.....	1 - 24
DR 188	Work Order.....	1 - 25
@ DR 203	<del>DBE Performance Record.....</del>	<del>1 - 26</del>
DR 204	Weekly Force Account Statement.....	1 - 27
@ DR 289 298	Special Training Provision Monthly On-the-Job Training Report.....	1 - 28
DR 344	Evaluation of Contractor.....	1 - 29
DR 439	EEO Contractor's Self-Analysis.....	1 - 30
DR 441	Identification of DBE Goal Achievement.....	1 - 34
DR 442	Identification of Work Performed.....	1 - 35
	Contractor EEO Compliance Record	

## EARTHWORK FORMS

DR 8	Water Applied Haul Sheet .....	1 - 37
DR23	Moisture Density Relations of Soils.....	1 - 38
DR 64	Site Release .....	1 - 39
DR 86	Weekly Report of Moisture ad Density Tests (or Computer Printout) .....	1 - 40
DR 99	Earthwork Computations .....	1 - 41
DR 101	Truck Capacity Computations.....	1 - 42
DR 210	Moisture Density Test.....	1 - 43
DR 232	Final Status Material and Site Releases .....	1 - 44
DR 264	Field Gradation Tests of Gravel For.....	1 - 45
DR 309A,B,C	Contractor's Estimate (Fuel Adjustment Computations).....	1 - 46
DR 324	Source of Aggregate to be Used.....	1 - 51
DR 348	Material Pit Contract Release .....	1 - 52
DR 478	Nuclear Density Record.....	1 - 53

## LIGHTING, SIGNS & TRAFFIC CONTROL FORMS

DR 502	Construction Signs and Posts.....	1 - 55
--------	-----------------------------------	--------

## ASPHALT FORMS

DR 29	Daily Summary of Scale Weights.....	1 - 57
DR 62	Weight Ticket.....	1 - 58
DR 173	Test and Pay Factor Summary .....	1 - 59
DR 193	Transfer of Asphaltic Material .....	1 - 60
DR 194	Pavement Profile Measurements Using a California-Type Profilograph .....	1 - 61
DR 418	Asphaltic Aggregate Design (Computer Generated Replacement) .....	1 - 62

## PCC PAVEMENT FORMS

DR 45	Concrete Proportioning and Cylinder Identification Report.....	1 - 64
DR 85	Daily Report of Concrete Pavement Laid .....	1 - 65
DR 478	Low Slump/High Density Concrete Nuclear Density Record .....	1 - 66

## BRIDGES, CULVERT & RELATED STRUCTURE FORMS

DR 24	Driveway Drainage Structures .....	1 - 68
DR 97	Pile Record.....	1 - 69
DR 175	Reinforcing Steel Sample Identification Report.....	1 - 70
DR 214	Report of Shipment of Prestressed and/or Precast Concrete Units From Tested Stock .....	1 - 71
@ RDP 50/504	Girder Shims .....	1 - 72

**ROADSIDE DEVELOPMENT FORMS**

DR 61 Project Seeding Record..... 1 - 75  
DR 125 Fertilizer Certification ..... 1 - 76

**INCIDENTAL CONSTRUCTION FORMS**

DR 5 Operation and Equipment Rental Agreement ..... 1 - 78  
DR 195 Guardrail..... 1 - 79  
DR 247 Report of Shipment of Precast Concrete Right-of-Way Markers from  
Approved Stock ..... 1 - 80  
DR 284 Report of Shipment of \_\_\_\_\_ Guardrail and/or Fittings ..... 1 - 81

**MATERIALS FORMS**

DR 12 Sample Identification Form ..... 1 - 83  
DR 181 Letter of Certification by Project Manager ..... 1 - 84  
DR 274 ~~Test Status Report..... 1 - 85~~

@



**SAFETY INSPECTION CHECKLIST**  
(Safety and Health Regulations for Construction)

This compliance inspection is intended to give a general view of possible violations a Federal Compliance Officer may find. It is not intended to be a comprehensive inspection. The State of Nebraska Department of Roads will be found by any comments made by Department personnel that are contained herein, nor by the failure of the Department personnel to point out a specific hazard or hazards. Statements contained herein are not to be construed as the Department of Roads approval or disapproval of the contractor's methods of complying with Federal Safety Regulations.

Project: I-80-0 (100)  
Project Manager: Arthur Jones  
Inspected by: Bill Smith

Contractor: Avid Construction Company, Inc.  
Date: June 31, 1996

Item	SAFETY ACTION		SAFETY ACTION		SAFETY ACTION	
	UNSATISFACTORY	NOT APPLICABLE	UNSATISFACTORY	NOT APPLICABLE	UNSATISFACTORY	NOT APPLICABLE
<b>SUBPART C - GENERAL SAFETY AND HEALTH PROVISIONS</b>						
1. Housekeeping (1926.25)	X					
<b>SUBPART D - OCCUPATIONAL HEALTH AND ENVIRONMENTAL CONTROLS</b>						
1. Medical Services (1926.50)	X					
2. First Aid Kits (1926.50)	X					
3. Telephone Numbers Posted (1926.50)	X					
4. Drinking Water (1926.51)	X					
5. Toilet (1926.51)	X					
<b>SUBPART E - PERSONNEL PROTECTIVE AND LIFE SAVING EQUIPMENT</b>						
1. Hard Hats (1926.100)	X					
2. Hearing Protection (1926.101)	X					
3. Eye and Face Protection (1926.102)	X					
4. Respiratory Protection (1926.103)	X					
5. Safety Belts and Lifelines (1926.104)	X					
6. Safety Nets (1926.105)	X					
7. Life Jackets and Skirt (1926.106)	X					
<b>SUBPART F - FIRE PROTECTION AND PREVENTION</b>						
1. Fire Protection Program (1926.150)	X					
2. "No Smoking Signs" in Hazardous Areas (1926.151)	X					
3. Open Yard storage of combustible material (1926.151)	X					
4. Approved containers and portable tanks (1926.152)	X					
5. Fire extinguishers (1926.152)	X					
6. Temporary Heating Devices (1926.154)	X					
<b>SUBPART G - SIGNS, SIGNALS AND BARRICADES</b>						
1. Traffic Signs Posted (1926.200)	X					
2. Inapplicable Signs covered or removed (1926.200)	X					
3. Flagmen Wearing Red Orange Garments (1926.201)	X					
4. Barricades (1926.202)	X					
<b>SUBPART H - MATERIALS HANDLING, STORAGE, USE AND DISPOSAL</b>						
1. Material stored and secured (1926.250)	X					
2. Rigging equipment checked (1926.251)	X					
<b>SUBPART I - TOOLS - HAND AND POWER</b>						
1. Power tools guarded (1926.300)	X					
2. Pressure release shut-off switch on certain hand-held power tools (1926.300)	X					
3. Hand tool condition (1926.301)	X					
4. Safety clips on pneumatic tools (1926.302)	X					
5. Fuel powered tools stopped while being refueled, serviced or maintained (1926.302)	X					
<b>SUBPART J - WELDING AND CUTTING</b>						
1. Gas cylinder valve protected (1926.350)	X					
2. Fire extinguisher available (1926.352)	X					
<b>SUBPART K - ELECTRICAL</b>						
1. Electrical tools - Grounded (1926.401)	X					
2. Extension cords, 3 wire type (1926.401)	X					
<b>SUBPART L - LADDERS AND SCAFFOLDING</b>						
1. Ladder condition (1926.450)	X					
2. Ladders extend not less than 36" above landing and secured (1926.450)	X					
3. Scaffolding - solid footing (1926.451)	X					
4. Guard Rails above 10' (1926.451)	X					
5. Guard rails 42" high (1926.451)	X					
6. Topboards 4" high (1926.451)	X					
<b>SUBPART N - CRANES, DERRICKS, HOISTS, ELEVATORS, AND CONVEYORS</b>						
1. Rated load capacities, recommended operating speeds, hazard warnings, posted at operators position (1926.550)	X					
2. Moving parts - guarded (1926.550)	X					
3. Swing radius of crane barricaded (1926.550)	X					
4. Crane Booms, Minimum 10' clearance from energized powerlines (1926.550)	X					
5. Conveyors - Audible Warning System (1926.555)	X					
<b>SUBPART O - MOTOR VEHICLES, MECHANIZED EQUIPMENT AND MARINE OPERATIONS</b>						
1. Unattended equipment, parked adjacent to highways at night have lights, reflectors or blades, buckets, or dump bodies grounded or blocked when not in use (1926.600)	X					
2. Motor vehicles in safe driving condition (1926.601)	X					
<b>SUBPART P - ESCAVATIONS, TRENCHING AND SHORING</b>						
4. Rubber-tired motor vehicle equipped with fenders (when required) (1926.602)	X					
5. Earthmoving equipment equipped with seatbelts (1926.602)	X					
6. Equipment with obstructed view has audible backup signal alarm or signalman (1926.602)	X					
7. Site-clearing equipment equipped with rollover guards, overhead and rear canopy (1926.604)	X					
<b>SUBPART Q - CONCRETE, CONCRETE FORMS AND SHORING</b>						
1. Excavation Inspected After Rainstorm or other hazard (1926.651)	X					
2. Excavated Material Stored and Retained at least 2' from edge of the excavation (1926.651)	X					
3. Banks more than 5' high shored or sloped to the angle of repose (1926.652)	X					
4. Exit ladder within 25' of work area 3' above the top (1926.652)	X					
<b>SUBPART R - TUNNELS AND SHAFTS, CAISSONS, COFERDAM, AND COMPRESS AIR</b>						
1. Tunnels - two means of rapid exit provided (1926.802)	X					
<b>SUBPART U - BLASTING AND THE USE OF EXPLOSIVES</b>						
1. Employer shall inventory and use record of all explosives (1926.900)	X					
2. No blasting during the progress or approach of a thunderstorm (1926.900)	X					
3. Qualified blaster (1926.901)	X					
4. Explosives not transported with other materials (1926.902)	X					
5. Blasting caps and explosives not transported in same vehicle (1926.902)	X					
6. Detonators and explosives stored in separate facilities (1926.904)	X					
7. No smoking signs posted at storage facility (1926.904)	X					
8. Highway traffic stopped during blasting operations (1926.909)	X					

OPTIONAL  
INSTRUCTION FOR USE OF SAFETY INSPECTION CHECKLIST

@

The Safety Inspection Checklist was developed from the Informational Guide on Occupational Safety on Highway Construction Projects published by A.A.S.H.O. Construction Safety and Health Regulations published in the Federal Register. Each item on this checklist is referenced by subsection number to the Informational Guide and it will be necessary for Project Managers and their designated representatives to be familiar with each specific subsection listed on the checklist, prior to making the inspection.

This inspection shall be performed by the Project Manager or the designated representative and shall be signed and dated by whomever, in fact, performs the inspection.

This inspection shall initially be required when substantial construction begins on a contract by the prime contractor or subcontractor on the contract at that time, until the work is completed, with the exception that monthly inspections will not be required when the work is suspended. In the case of the prime contractor, the safety checklist shall be made in triplicate with one copy becoming part of the project records. The original shall be given to the contractor's supervisor on the site, while the other copy shall be sent to the contractor's home office to the attention of the contractor's safety officer.

In the case of a subcontractor, the safety checklist shall be made in triplicate with one copy becoming part of the project records. The original shall be given to the subcontractor's supervisor on the site, while the other copy shall be given to the prime contractor's supervisor on the site.

If, in the opinion of the Project Manager or the designated representative, a possible violation of the OSHA regulations exists, he shall place a check in the satisfactory column for the specific area provided on the checklist.

In the case where the Project Manager or the designated representative has indicated an unsatisfactory condition on the safety checklist, he/she shall, at the time he/she presents the original to the contractor's supervisor on the site, explain to the contractor's supervisor the basis of his/her opinion that an unsatisfactory condition exists. In no case should the Project Manager or the designated representative advise the contractor on the method(s) to correct the unsatisfactory condition.

In cases where, in the opinion of the Project Manager or the designated representative, a situation which constitutes an imminent danger to life or limb exists, he/she shall request immediate abatement of the danger or if immediate abatement is not possible, removal of the employees from the danger area. In the event of contractor refusal to cooperate in eliminating an imminent danger situation, the Project Manager or the designated representative shall suspend work on the project and notify the nearest OSHA office immediately. In the case where the work is suspended the District Engineer, the Lincoln Construction Division and the contractor's home office should be notified immediately.

The Project Manager or the designated representative should not assume that the performance of these monthly inspections relieve him/her of his/her duty to notify the contractor of possible violations which may be discovered at any time during the course of the work. The Project Manager or the designated representative should notify the contractor's representative on the site, of any possible violation, at any time the Project Manager or the designated representative believes a possible violation exists.

@

This information must be given to the project manager prior to beginning work, preferably at the preconstruction conference.

### DBE PERFORMANCE RECORD

Submitted by John Jones of Small Construction Co.

Project Number E-6-7 (1030) Location \_\_\_\_\_

Prime Contractor Cyclone Construction Co Amount of Subcontract \$50,000.00

Description of work to be performed. Identify by group or line item and type of work.  
Group 7B - 1000 m of 1.83 m high chain link fencing to be  
\_\_\_\_\_  
\_\_\_\_\_

List of owned equipment to be used on this project.  
300 mm post hole auger \_\_\_\_\_  
Mobile cement mixer \_\_\_\_\_  
\_\_\_\_\_

List of leased equipment to be used on this project. Attach a copy of the lease.  
Grader \_\_\_\_\_  
\_\_\_\_\_  
\_\_\_\_\_

Name of superintendent assigned to this project John Jones of Small Construction Co

Names of foremen assigned to this project Paul Jones

If local labor is to be used, who is responsible for hiring Paul Jones

Who is responsible for ordering materials John Jones

Who is authorized to accept deliveries John or Paul Jones

List of materials and supplies needed for this project and source of supply  
300 poles at 37.5 mm diam x 2.1 m length Menards Lumber, Paillion  
1000 m of chainlink fence fabric " " "  
Cement 300 Sacks " " "  
\_\_\_\_\_  
\_\_\_\_\_

Do you have an agreement for the issuance of joint checks for supplies? Yes  No \_\_\_\_\_

List workers to be used on this project. If worker is a regular employee, show their name. If not yet hired, indicate if to be local hire. Use another sheet if necessary.

Trade	Name	Local Hire
<u>Carpenter</u>	<u>James Green</u>	<u>Yes</u>
<u>Carpenter</u>	<u>Sheila Smith</u>	<u>Yes</u>
_____	_____	_____
_____	_____	_____

**TEST STATUS REPORT**  
**MATERIALS & TESTS DIVISION**

@

To	<b>John Plow (Project Manager)</b>	Project No.	<b>F-81-1(1018)</b>
		Location	<b>I-80</b>
Date	<b>April 2, 1996 – Second Notice</b> <b>February 13, 1996 – First Notice</b>	Contractor	<b>Cyclone Construction</b>

The following summary shows the status of test data in the files on this date for the above project. Possibly some of the missing tests have been completed but not yet reported. Some of the test data may have been lost, or the materials may be represented by tests on other state work. Would you please review your files and send us copies of the missing reports, or advise us of any pertinent information which you might have regarding these tests.

**Need reports for the following items:**

**fasteners & reflectors for Type 1 delineators**

**5' chain link fence – 200 lineal feet**

**posts**

**std steel pipe**

**fittings & hardware**

**tie wire**

**pull box type PB-5 – 20 required**

**1) Rhonda Hergenrader, Materials & Tests Division, sends this form out**

**traffic signals, Types:**

**TS-1 – 30 required**

**2) First Notice to Project Manager is E-Mailed thru Office Vision**

**TS-1LL – 4 required**

**TS-1A – 4 required**

**pedestrian signal, type PS-1 – 16 required**

**pedestrian push button, PPB – 4 required**

**power installed foundations**

**luminaires types:**

**UD-200 – 4 required**

**HPS – 20 required**

**Conduits types:**

**2" PVC**

**3" PVC**

**2" PVC augered**

**2" on bridge**

**cc: District Engineer**  
**District Construction Engineer**

# INDEX

1

1 CALL - Diggers Hotline of Nebraska ..... 147

1995 Metric Supplemental Specifications ..... 75

1-Point Curve Method..... 170

1-Point Moisture Density Curve ..... 170

3

3 m (10 foot) Straightedge ..... 98

4

40 CFR 117..... 522

404 Determination Checklist ..... 495

404 Permit ..... 493, 494

A

A.G.C. Training Program ..... 51

Abrasive Blast Cleaning..... 514

Abutment ..... 375

Accelerating Admixtures ..... 385

Acceptable Mulch ..... 448

Acceptance ..... 125

Acceptance Letter ..... 126

Accident Notification Procedure ..... 209

Accident Report..... 208

Additional Estimates ..... 142

Adjacent Land ..... 142

Adjusting Aggregate Proportions..... 234

Adjusting Asphalt Cement Contents ..... 233

Admixture Dispensers..... 274

Admixtures ..... 270, 382

AEA ..... 285

AED Green Book..... 76

Aerial Photo ..... 165

Aggregate ..... 189, 285

Aggregate Scale..... 290

Aggregates..... 233, 281

Agitators ..... 274, 277

Agreed Unit Price ..... 80

Agronomist..... 152

AHERA ..... 488

Air Compressors..... 302

Air Entraining Admixture ..... 272

Air Entraining Admixtures..... 382

Air Entraining Agent..... 271

Air Entrainment ..... 271

Air Quality ..... 487

Air Temperature ..... 246

Air Voids ..... 234

Air Voids Test..... 233

Alignment Book ..... 555

All Land Corners..... 545

Allowable Area Error..... 110

Alteration..... 103

Alterations..... 89

Altered Quantities..... 102

An Equal Opportunity Employer ..... 30

Annual EEO Report..... 43

Appealed Decisions ..... 9

Application of Fertilizer ..... 447

Apply Fertilizer ..... 450

Apprentices..... 54

Approach Sections..... 402

Approach Slabs ..... 178

Approval..... 80, 166

Approved Products List ..... 478, 479

Approved Rates ..... 87

Approximate Length of Authorized Open Grading  
     Areas ..... 459

Arc Blow ..... 361, 362

Arch Culverts ..... 418

Army Corps 404 Permits ..... 493

As Built ..... 201

As Built Plans ..... 132, 133

Asbestos Hazardous Emergency Response Act... 488

Asbestos Removal ..... 520

ASCS Aerial Photos..... 165

Asphalt Bases..... 245

Asphalt Binder ..... 256

Asphalt Curbs ..... 257

Asphalt Materials ..... 232

Asphalt Mixture ..... 233, 255

Asphalt Pavement..... 232

Asphalt Pavement Equipment..... 236

Asphalt Plants..... 236

Asphalt Report Forms ..... 234

Asphalt Shoulders..... 246

Asphaltic Concrete Paving Plant Inspection ..... 92

Asphaltic Concrete Surface Course ..... 114

ASTM C 94..... 286

ASTM Standard Reinforcing Bars ..... 376

Authority ..... 1, 9

Authorized Alterations ..... 102

Auxiliary Finisher..... 293

## B

Backer Rod..... 303

Backfill..... 151

Backplates..... 205

Backslope Drains ..... 472

Balance Factor..... 163

Balance Points..... 556

Bale..... 452

Bar Designation System ..... 375

Barricades ..... 62, 220

Barricades/Plastic Drums ..... 221

Barrier Rails..... 403

Base Course..... 114, 176, 189

Base Plate ..... 342

Base Plates ..... 342

Basis of Payment ..... 441

    Foundation Course ..... 185

Batch Plant ..... 270

Batch Quantities ..... 281

Batch Scales..... 96

Batch Volume Underruns ..... 290

Batching Cycle .....	284	Brush.....	160
Batching Equipment .....	273	Bulbs.....	205
Batching Inspections .....	281	Bulkhead .....	281
Batching Operations .....	284	Bump Correction .....	99
BCT .....	470	Bumps.....	99
Bearing .....	317	Burial Ground .....	166
Bearing Capacity.....	321	Burlap.....	298
Beginning the Counting of Working Days.....	67	Burlap Marks .....	297
Bell .....	420	Burning.....	160
Bell Ends.....	203		
Belt Placement .....	393	C	
Bench Levels.....	536	C.S.....	535
Benching.....	168	CAAA .....	488
Benchmarks .....	536, 537, 551	Cabinet.....	204
Berm.....	168	Cabinet Doors.....	205
BEST .....	470	Cable Bracing.....	340
Binder .....	245	Cable Sheath.....	204
Bituminous Pavement.....	227	Calendar Day.....	67
Blanking Bands .....	304	Calibration of Concrete Proportioning Equipment.....	392, 407
Blue Book .....	75	Cancelled Items .....	103
Blue Top .....	557	Carbon Streaks.....	414
Blue Top Book.....	555	Care of Equipment .....	579
Blue Top Books.....	557	Cast-In-Place (Retrofit) Barrier Rail.....	410
Blue Tops.....	152, 158	Cast-in-Place Concrete .....	315
Bolts .....	350	CD Terminal Section .....	470
Bonded PCC Overlay .....	307	Cement Bulk Handling Equipment .....	273
Borrow .....	121	Cement Car Record .....	283
Borrow and Local Pit Materials Furnished by the State or County and Not Involving the Contractor.....	122	Cement Factor.....	283
Borrow Pit .....	165, 166, 559	Cement Hauling Inspections.....	283
Borrow Pits .....	182, 559	Cement Notebook .....	283
Bottom of Slab.....	368	Cement Received .....	283
Boulders .....	171	Centerline Tie Bars .....	290
Bound Field Books .....	571	Centerlines .....	554
Box Culvert .....	540	CERCLA.....	487, 488
Box Culvert Footing.....	330	Certificate of Compliance .....	272
Box Culvert Structures.....	541	Certificates of Compliance.....	477
Box Culverts.....	117	Certification .....	301
Box-Outs.....	289, 290	Certification of Materials.....	232
Break .....	242	Certified Plant Inspector Program .....	234
Break Back Tops.....	541	Certified Tests .....	477
Breakaway End Anchorage Post.....	470	Chain of Command .....	4
Bridge Approach Fills.....	170	Change Orders .....	26
Bridge Approach Guard Rails.....	220	Change Order-Supplemental Agreements.....	81
Bridge Approach Smoothness.....	98	Changeable Message Sign.....	214
Bridge Approach Tapers.....	241	Character of Work.....	89
Bridge Capability .....	237	Character of Workpersons.....	70
Bridge Connections .....	470	Checklist Safety Program .....	63
Bridge Deck and Approach Slab Smoothness.....	413	Chemical Finishing.....	294
Bridge Deck Repair .....	325, 405	Chipping .....	160
Bridge Deck Smoothness .....	98	Class I Embankments .....	169
Bridge Decks and Overlays.....	404	Class I Floor Repair .....	407
Bridge Diaphragms.....	363	Class II Embankments .....	169
Bridge End Condition.....	220	Class III Embankments .....	169
Bridge Ends .....	220	Clean Air Act Amendments.....	488
Bridges .....	329	Clean Water Act.....	488
Bridges and Special Culverts .....	134	Cleaned Finish.....	395
Bridges-Steel Beam.....	345	Cleaning Joints .....	302
Broken Signing.....	222	Clearance Letter .....	136
Broken-Back Culvert.....	540	Clearance of Bottom Reinforcement .....	368
Brome Grass.....	448	Clearance of Slab Reinforcement .....	369
		Clearing & Grubbing.....	147

Clearing and Grubbing.....	160	Conflict of Interest.....	10
Closed Abrasive Blast.....	515	CONFILM.....	410
Closure Notification.....	500	Construction Critical Area.....	264, 267
Closure Report.....	504	Construction Critical Areas.....	231, 266
Cloud Cover.....	246	Construction Division.....	2, 3
Coarse Aggregate.....	189	Construction Division (EEO Section).....	46
COFA.....	79	Construction Engineer.....	4
Cold Seasons.....	308	Construction Inspection.....	66
Cold Weather.....	246, 308	Construction Joints for Box Culverts.....	400
Cold Weather Asphalt Construction.....	246	Construction Methods.....	440
Cold Weather Paving.....	308	Construction Period.....	57
Cold Weather Placement.....	409	Construction Requirements.....	193
Cold Weather Plant Operation.....	308	Construction Stakes.....	531
Collars.....	117	Construction Staking.....	36
Collars with Bend.....	117	Construction Survey.....	571
Collecting of Accident Data.....	101	Construction Surveying.....	531
Coloring Agents.....	382	Construction Technician (CT).....	7
Commercially Useful Function.....	55	Construction Work Zone Signing During Winter Shutdown.....	211
Communication Division.....	14	Construction Work Zone Traffic Control.....	207
Compacted Base Course.....	185	Construction Zone Accident Report.....	208
Compacted Layer.....	182	Construction Zone Accident Reporting.....	208
Compaction.....	149, 169, 185	Consultant.....	12
Compaction Requirements.....	279	Consultants.....	16
Compensation.....	102	Containment.....	516
Compliance and Enforcement.....	487	Contaminated Soil.....	502
Composite Girders.....	364	Contamination.....	501
Composition of Concrete.....	270, 378	Contingencies.....	119, 136
Comprehensive Environmental Response, Compensation, and Liability Act.....	488	Contract Quantities.....	59
Concrete.....	319	Contract Administration.....	1
Concrete Barrier Rails.....	402	Contract Documents.....	26
Concrete Box Culverts.....	418	Contract Time Determination.....	66
Concrete Bridge Floors Checklist.....	322	Contract Time Extensions.....	99
Concrete Construction.....	118, 378	Contract Unit Price.....	79
Concrete Construction Checklist.....	321	Contraction Joints.....	299
Concrete Cylinders.....	578	Contractor Borrow.....	164
Concrete Discharge Times.....	271	Contractor Evaluations.....	136
Concrete Driveways.....	309	Contractor Furnished Borrow Areas.....	164
Concrete Elbows, Collars.....	117	Contractor Furnished Construction Survey.....	570
Concrete Headwalls.....	117	Contractor Markup.....	79
Concrete Mixers.....	273	Contractor Requirements.....	459
Concrete Mobile Mixers.....	404	Contractor-Owned Equipment.....	75
Concrete Pavement.....	114, 269	Contractor's Sales Tax Exemption.....	60
Concrete Pavement Checklists.....	263	Contractor's Schedule.....	459
Concrete Pavement Failures.....	298	Contractor's Standard Forms.....	235
Concrete Pavement Repair Checklist.....	267	Contractor's Work Schedule.....	73
Concrete Piling.....	315	Control Joints.....	300
Concrete Pipe Culverts.....	118, 420	Controlled-Access.....	59
Concrete Placement.....	344	Controller.....	204
Concrete Plant Checklist.....	265	<i>Conventional</i> Light Poles.....	199
Concrete Sampling Locations.....	270	Corners.....	545
Concrete Seal Course.....	115, 330	Corps of Engineers.....	165
Concrete Shoulders.....	296	Correcting Earthwork Areas.....	111
Concrete Spreader.....	275	Corrugated Metal Pipe.....	119
Concrete Strength.....	270	Corrugated Metal Pipe Arches.....	119
Concrete Surface Finish (Rail and Beams).....	395	Corrugated Metal Pipe Culverts.....	422
Concrete Temperature.....	407	Corrugated Metal Pipes.....	422
Concrete Ticket.....	286	Cost Overrun/Underrun Notification Letters.....	85
Conductors.....	193	County Weed Control Authority.....	448
Conduit.....	205	Covercrop Seeding.....	152, 458
Conduit Ends.....	203	Covercrop Seeding Checklist.....	458
Conduits.....	193	COVR.....	136

CR MS-3.....	238	Delayed Estimates.....	126
Cracking.....	360	Delegation of Authority.....	1
Cracks.....	300	Delegation of Responsibility.....	7
Crane and Bucket.....	393	Delineators.....	181
Crimped In.....	448	Densities.....	177
Crop Damage.....	127	Density.....	158, 182
Cross Drains		Density - Void Conflicts.....	244
Longitudinal.....	472	Density Controls.....	242
Cross Section.....	561	Density Samples.....	243
Cross Sections.....	178, 568	Density Tests.....	183
Crown.....	275, 290, 293	Department of Environmental Quality (DEQ).....	487
Crown Check.....	275	Dept. of Water Resources Flood Plain Permits.....	494
Crown Checks.....	291	DEQ.....	485
Crushed Rock.....	189	Design Data Listing.....	555
Crystalline Silica Exposure & OSHA Notification.....	64	Design Mix.....	281
CSS-1.....	241	Detour.....	100
CSS-1H.....	241	Detour Report.....	24
Cultural Resources.....	166	Detour Signs.....	62
Culvert.....	418	Dewater.....	330
Culvert Excavation.....	116, 329	Diamond Grinding.....	306
Culvert Footings.....	418	Diesel Hammers.....	333
Culvert Lengths.....	537	Diggers Hotline.....	29, 37
Culvert List.....	422, 538, 540	Diluted Emulsion.....	241, 242
Culvert Lists.....	537	Diluted Emulsions.....	242
Culvert Pipe.....	120, 420, 423	Diluted Material.....	241
Culverts.....	118, 134, 329, 542	Dilution of Emulsion.....	241
Curb.....	289, 297	Director-State Engineer.....	1
Curing.....	297, 304, 409	Disadvantaged Business Enterprise (DBE).....	54
Curing of Keyed and Doweled Joints.....	304	Discharge Cycle.....	284
Current Controlling Operation.....	67	Disk.....	543
Curvature.....	111	Disposal of Asphaltic Concrete Pavement.....	162
Curve.....	446	Disposal of Waste.....	160
Curve Data.....	563	Disposal Options.....	502
Curves.....	558	Distribution of Materials.....	187
Cutback Asphalt.....	246	District Construction Engineer (DCE).....	5
CWA.....	488	District Engineer (DE).....	5
Cyclone Seeder.....	436	District Maintenance Engineer.....	201
Cylinder.....	401	Ditch Control.....	452
<b>D</b>			
Daily Cement Record.....	283	Ditches.....	559
Daily Plant Operation.....	235	Divided Highway Condition.....	220
Daily Plant Report.....	233, 234	Do Not Pass (R4-1).....	213
Daily Record.....	88	Double.....	218
Daily Report of Concrete Pavement Laid (DR Form 85).....	310	Dowel Assembly Placement.....	303
Dam.....	170	Dowel Bars.....	288, 298
Damage Due To Siltation.....	460	Dowel Baskets.....	288
Damaged Edges.....	305	Dowel Midpoint Markings.....	304
Damaged Equipment.....	578	Dowel Tolerances.....	303
Damaged Signing.....	222	Doweled Support Assemblies.....	303
Damaged Signs.....	222	DR Form 100.....	208
Data Collector.....	109	DR Form 11.....	208
Davis-Bacon.....	49	DR Form 16.....	100
DBE.....	54, 56	DR Form 22.....	272
DBE Owner.....	56	DR Form 41.....	209
Deck Overlay.....	402	DR Form 42.....	19
Deck Overlay Preparation.....	407	DR Form 75.....	551
Deduction.....	188	DR Form 84.....	52
Deduction for Signs.....	222	DR Form 85.....	290
Defects.....	374	DR Form 91.....	125
Deficiency.....	183	Drag Finish.....	294
		Drainage.....	150
		Drainage Structure Locations.....	538
		Drill Settings.....	436



Driver's Motor Vehicle Accident Report .....	209
Driveway Grades.....	280
Driveway Run Outs.....	241
Driveways .....	280
Dry Film Paint Thickness .....	416
Drying and Recompaction.....	239
Dump Trailers.....	238
Dust.....	514
Dust Emissions .....	514
Dynamic Pile Analyzer.....	333

## E

E.E.O. Meetings .....	30
E.E.O. Officer .....	30
E.E.O. Policy.....	30
E.E.O. Posters .....	30
Earth Shoulder Construction .....	181
Earth Shouldering.....	100
Earthwork Computation Listing .....	555
Earthwork Engineering Guide .....	177
Earthwork Inspection Checklist .....	145
Earthwork-Measured-in-Embankment .....	163, 171
Earthwork Measurement Conversion.....	129
Edge Alignment.....	240, 241
Edge of the Traveled Way.....	181
EEO Policy Statement .....	30
EEO Requirements.....	29, 42
EEO Violations .....	44
Electrometer.....	375
Electric Power .....	201
Electrical Power.....	203
Electronic Digital Theodolite/Transfer .....	574
Embankment Construction.....	168
Embankment/Excavation Procedures .....	145
Emergency Notification.....	486
Employee Policies .....	17
Emulsion .....	242
Emulsions .....	241
End Anchorage .....	470
End Gate Cyclone Seeder .....	436
End Road Work.....	210, 220
Engineering Equipment .....	572
Engineering, Surveying and Testing Equipment....	572
Entrained Air .....	271
Environmental .....	485
Environmental Regulations .....	486
EPA .....	485, 487
Epoxy Coated Bar .....	370
Epoxy Coated Bars.....	372
Epoxy Coating.....	373
Epoxy Coating Thickness .....	375
Epoxy-Coated Reinforcement .....	371
Equal Employment Opportunity.....	36
Equal Employment Opportunity (EEO) .....	42
Equations.....	561
Equipment.....	76, 188, 210
Rented.....	76
Equipment Inventory.....	580
Equipment Operators.....	76
Equipment Purchased .....	124
Equipment Rental.....	76
Equipment Rental Rates.....	86

Equipment to be Used.....	36
Erosion Checks.....	452
Erosion Checks Checklist.....	452
Erosion Control.....	451, 452
Erosion Control Checklist .....	451
Erosion Control Plan .....	435
Errors .....	12
Established Quantities.....	164
Estimate, "Additional".....	142
Estimates.....	106
ET2000.....	470
Evaluation.....	413
Evaluation of Contractor .....	137
Evaporation Retarders .....	294
EVLCTRTR.....	138
Example Calculation .....	448
Example Calculations.....	445
Excavation.....	115, 163, 164, 559
Excavation (Established Quantity) .....	163
Excavation Borrow .....	163, 164
Excavation for Bridges .....	115
Excavation for Culverts .....	116
Excavation for Structures .....	329
Excavation Operations .....	498
Excessive Edge Slump.....	305, 306
Exempted .....	20
Exemptions from Subcontract Requirements.....	20
Existing Stop Signs .....	209
Expansion Device .....	401
Expansion Joints.....	290, 294
Expendable Abrasive .....	514
Extra Work.....	85, 177, 178

## F

Failures .....	177
Fair Labor Standards Act.....	49
False Statements .....	11
Falsework.....	345
Falsework Design .....	339
Falsework Foundations .....	338
Falsework Inspection .....	337
Falsework Piles.....	338
Falsework Plans .....	336
Farm Tanks .....	499
Fast-Ball.....	447
Fasteners .....	356
Federal Water Pollution Control Act.....	496
Fence .....	160
Fence Removal.....	160
Fence Stakes.....	570
Fertilizer .....	436, 445, 453
Fertilizer Checklist.....	445
Fertilizers	
Example Calculations .....	445
FHWA .....	15
Fiber Optic Cable .....	37
Field Adjustments .....	208
Field Approval of Subcontract Work.....	19
Field Book .....	154
Field Book Records.....	465
Field Computations .....	109
Field Cultivator.....	436

Field Documentation.....	393	Form Settlement .....	290
Field Inspection.....	372	Form WH 348 .....	49
Field Laboratories.....	465	Form WH-348.....	108
Field Notebooks .....	104	Forms.....	40, 277, 287, 387
Field Notes.....	571	Forms WH-348 .....	106
Field Records.....	104	Foundation .....	330
Field Testing Laboratory .....	186, 270	Foundation Course.....	112, 182, 279
Field Tests .....	94, 104, 232	Foundation_Engineer.....	151
Field Voids .....	233	Foundations.....	199, 331
Field Welding .....	336, 369	Freeways.....	216
Field-Checked List.....	538, 540	Freight Rates .....	61
Filler-Bitumen Ratio .....	234	Frost Boil.....	239
Final Cleaning Up.....	142	Full Depth PCC Patches.....	311
Final Computations.....	125	Fully Operated .....	76
Final Cross Section Notebooks .....	569	Fully Operated Rates .....	87
Final Cross Sections.....	559, 562	Furnishing and Planting of Plant Materials .....	439
Final Estimate .....	124	Checklist .....	439
Final Inspection.....	125		
Final Payment .....	109, 124, 125	<b>G</b>	
Final Quantities .....	123, 553	G20-2.....	210
Final Quantities Protest .....	143	Galvanized Bolts.....	356
Final Records.....	126	Galvanized Metal Pipes.....	422
Final Review Process Manual.....	125	Gas Station.....	499
Final Signal Turn On.....	206	General Comments.....	438, 439, 449, 451, 452, 455
Finaling Procedures.....	141	General Permit 77-2.....	493
Fine Aggregate.....	189	Girder Shims.....	363
Fine Grading .....	176	Grade	
Finely Divided and Permeability .....	382	Alignment Stakes.....	531
Finely Divided Mineral Admixtures .....	385	Grade Stakes.....	37, 176
Fines Double .....	219	Gradeline Strings .....	240
Fines for Speeding Doubled in Work Zones..	218, 219	Grades and Surfacing	
Finish Grade Stakes .....	152, 158	Elevations Listing.....	555
Finish Grading.....	152, 171	Grades on Drives in Cities.....	280
Finish Sod.....	450	Grades, Lines & Profile .....	152
Finished Pavement.....	245	Grading .....	133, 158
Finishing .....	171	Grading Diary .....	153
Finishing Equipment.....	275, 280	Grading Inspector .....	158
Finishing Machine.....	275, 291, 408	Grading Operation .....	145
Finishing Machines.....	245	Granular Base Courses .....	183
Finishing Stakes .....	557	Gravel .....	189
Firewood.....	161	Gravel Aggregates .....	176
Fixed Form Jersey & Retrofit Rail.....	403	Gravel Surfacing.....	113
Flagger .....	212	Gravity Seeder.....	436
Flagger Handbook.....	212	Grinding.....	413
Flaggers.....	212	Grooving.....	295
Flashing Arrow Panels.....	214	Ground Rod.....	205
Flexible Pavement Engineer .....	233	Grout.....	395
Flexible Pavements .....	565	Guardrail .....	121, 181, 220
Flexible Payments.....	177	Guardrail Checklist.....	466
Floated Surface Finishes .....	395	Guardrail Inspection.....	468
Flood Plain Permits .....	494	Guardrail Installations .....	468, 469
Floor Drains .....	409	Guardrail Posts.....	469
Fly Ash.....	176	Guidance.....	527
Fly Ash (Class C & F) .....	386	Guide Stakes .....	542
Force Account.....	80	Guideline Strings .....	240
Force Account Agreements.....	86	Guidelines .....	75
Force Account Statements.....	88	Guidelines for Tining .....	296
Form Alignment Ahead of Paver .....	287	Gutter.....	289
Form FHWA 1273 .....	51		
Form FHWA-1391 .....	43	<b>H</b>	
Form FHWA-47 .....	109, 131	H Pile .....	320
Form Setting .....	287	H.I. Data.....	562

Hair Checks .....	297	Implementation Schedule .....	527
Hammer Data Sheet .....	321	Imprest Inventory .....	103
Hand and Power Tool Cleaning .....	515	Inactive Graphics Road Design System .....	554
Hand Rails .....	413	Incentive/Disincentive Payment .....	252
Hand Tool Cleaning .....	515	Incidental Construction .....	465
Handrail .....	413	Inertial Barrier Systems .....	220
Hardware .....	413	Inlet .....	289
Haul Roads .....	39	Inlet Standards .....	289
Haul Time .....	287	Inspection	
Hauling .....	95, 182	Equipment .....	186
Hauling Equipment .....	274	Inspection Crew .....	227, 263, 265, 267, 442, 449, 451, 452, 455, 456, 457, 458
Hauling Materials .....	187	Inspection Equipment .....	193, 227, 263, 265, 267, 438, 439, 449, 451, 452, 455, 456, 457, 458
Hauling On Or Over Surfaced Roads .....	168	Inspection Notebooks .....	104
Hazardous Waste Designation .....	518	Inspection Procedures .....	227
Head of the Pile .....	319	Inspector's Records & Forms .....	231
Head to Head .....	100	Insulation .....	308
Header .....	298	Integral Curb .....	297, 300
Header Boards .....	298	Integrity .....	10
Head-to-Head Projects .....	213	Interest .....	124
Health .....	63	Interest Date .....	477
Health Standards .....	63	Interest Payments .....	126
Heavy Disc .....	436	Interlocked Automatic Batching Controls .....	284
Heavy Hexhead Structural Bolts .....	348	Interpolated Cross Sections .....	568
Helpful Hints .....	169	Interpretation of Specifications .....	4
High Density Low Slump Concrete .....	327	Instate Traffic Control Requirements .....	213
High Mast Lowering System .....	200	Investigation Procedure .....	208
High Mast Towers .....	199		
High Production Pavement Projects .....	293	<i>J</i>	
High Range Water Reducing Admixtures (Type F) .....	384	Job Control Testing .....	235
High Strength Bolts .....	343	Joint Filling .....	302
High Strength Fasteners .....	349	Joint Sealer .....	301
Highway Right-of-Way .....	59	Joints .....	241, 298, 397
Highway Safety Division .....	208	Smoothness .....	254
Hiring .....	31	Junction Box in Bridge Curb .....	195
Historic Sites .....	492	Junk .....	160
Historical Society .....	498		
Holes in Poles .....	204	<i>K</i>	
Holiday Detector .....	375	Known Tanks .....	500
Hoppers .....	96		
Horizontal		<i>L</i>	
Curves .....	558	Labor Classification .....	50
Horizontal Construction Joint .....	398	Labor Laws Cited .....	48
Horizontal Reinforcement .....	369	Labor Market .....	31
Hot Box Samples .....	242	Laboratory Trailer .....	236
Hot Pour Joint Sealer .....	300	Land Application .....	503
Hot Pour Kettles .....	303	Land Quality .....	487
Hot Poured Asphaltic Joint Material .....	303	Land Survey Monuments .....	543
Hot Poured Sealants .....	300	Landfill .....	161
Hot-Pour Joint Sealer .....	480	Lane Shifts .....	215
Hourly Operating Costs .....	75	Lap Requirements .....	377
Hourly Rental Rate .....	75	Lapping of Guardrail .....	470
Hub Line .....	292	Lapping of Rail .....	470
Hubs .....	542	Large Tree Removal .....	160
Hydro-Seeder .....	436	Laydown	
<i>I</i>		Foundation Course .....	183
Idled Equipment .....	77	Laydown Procedures .....	230
IGRDS .....	554	Laying Out Joints .....	300
Immediate Danger .....	502	Laying Widths for Asphalt .....	245
Impact Attenuator .....	213	Leaking Underground Storage Tanks (LUSTs) .....	499
Impervious Coatings .....	297	Leaky Mixer Valves .....	285
Implement SiteManager .....	527		

Leased Equipment .....	76
Letter of Transmittal.....	141
Light Pole.....	198
Lighting.....	193
Lighting and Signals.....	135
Lighting Checklist.....	193
Lighting Control Center.....	195
Lighting Control Centers.....	200
Lighting Engineer.....	198
Limestone.....	189
Limitations.....	307
Line and Grade.....	292
Liquidated Damages.....	99, 124
Load Ticket.....	96
Local Pit.....	122
Local Purchase of Services.....	580
Localized Soil Erosion.....	511
Log of Work Area Speed Zones.....	223
Longitudinal Cracks.....	403
Longitudinal Drains.....	472
Longitudinal Joint Design.....	304
Longitudinal Joints.....	241, 300
Loop Wire.....	206
Loops, Preformed.....	203
Loops, Sawed.....	203
Lost Transverse Groove.....	306
Lotus Notes.....	102
Lowering System.....	200
Luminaires.....	199
Alignment.....	199
Orientation.....	199
LUSTs.....	499

*M*

Machine Finishing.....	293
Magnetic Detectors.....	204
Magnetic Dry film.....	416
Magnetic Dry Film.....	416
Magnetic Locator.....	288
Mailbox Turnouts.....	259
Mailboxes.....	181
Main Screed.....	292
Maintained Traffic.....	157
Maintenance Contracts.....	44
Maintenance of Survey Equipment.....	573
Maintenance Work.....	216
Major Item.....	79
Marking Joint Locations.....	304
Mass of Asphalt Cement.....	253
Mass Per Unit Volume.....	253
Mast Arms.....	204
Master Straightedge.....	276
Mastic Sealants.....	302
Mat Smoothness Machine.....	238
Material Certification.....	477
Material Certifications.....	477
Material Details.....	477
Material Inspections.....	280
Material Placement.....	235
Material Quantities.....	309
Material Requirements.....	439
Material Transfer Vehicle.....	237

Materials	
Salvaged.....	123
Maximum Air Temperature.....	407
Maximum Speed Limit.....	217
Measurement.....	102
Measurement of Quantities.....	102
Measuring Asphalt Materials.....	256
Mechanical Strike-off.....	275
Media Guide.....	14
MELT.....	470
Metal Chairs.....	288
Method of Measurement.....	181
Method of Measurement.....	179, 367
Metric System of Measurement.....	102
Microtest.....	375
Milling Machines.....	306
Millings.....	260
Mills.....	272
Mineral Filler.....	189
Minimum Allowable Asphalt Cement.....	233
Minimum Bolt Tension".....	353
Minimum Penetration.....	333
Mix.....	233
Mix Change.....	233, 234
Mix Design Letter.....	235
Mixer Performance Tests.....	274
Mixers.....	274
Mixing.....	285
Mixing and Hauling.....	284
Mixing Drum.....	274
Mixing Time of Asphalt Plants.....	236
Mobilization.....	77, 123
Moisture.....	158, 177, 182
Moisture Content.....	183
Moisture Density Curves.....	170
Monument.....	543, 551
Monuments.....	545
Motor Carrier Permit Office.....	95, 168
MTV.....	238
MTV-3500.....	237
Mud.....	418
Mud Ball Repair.....	307
Mudsills.....	338
Mulch.....	448
Mulch Crimper.....	436
Mulching Checklist.....	448
Mulching Machine.....	448
Multi-Contract Projects.....	211

*N*

National Geodetic Survey.....	543
National Pollutant Discharge Elimination System..	488
Nationwide Permit.....	493
Native (Prairie) Hay.....	448
Native American Village.....	166
Native Grass Seed Drill.....	436
NDR Approved Products List.....	478
NDR T 166.....	243
NDR T 168.....	243
NDR Tests.....	231, 264, 266, 268
Nebraska and Iowa Associated General Contractors Manpower Development and Training Programs	51

Nebraska One Call Notification System.....	29	P.I. ....	535
Negative Air .....	517	P.O.T.....	535
News Media Relationships.....	14	P.T. ....	535
No Noticeable Dust.....	517	Pad Mounted Controllers.....	205
No Passing Zones.....	555	Paint Film .....	415
No Passing Zones on Construction Projects.....	210	Paint Removal .....	514
NOI.....	509	Paint Thickness .....	416
Nomograph .....	271	Paint Waste Disposal.....	517
Non-cohesive Sand .....	180	Painting .....	367, 415
Nonhazardous Paint Waste .....	518	Paired Signs .....	208
No-Passing .....	210	Paleontological Work .....	498
No-Passing Zone.....	210	Pan Float.....	293
Normal (Dry) Borrows .....	512	Pan-Type Finisher-Float.....	275, 293
Notice of Disposition.....	518	Partial Payment .....	103
Notice of Intent (NOI).....	509	Partnering.....	15
Notification of Project Completion.....	125	Partnering Opportunities.....	37
NPDES .....	488	Patching Procedures.....	267
Nuclear Density Gauge.....	242	Paved Shoulders.....	245
Nuclear Gauges .....	170	Pavement	
Number of Hours.....	76	Damaged.....	305
<b>O</b>		Pavement Construction .....	269
Obstructions on Right-of-Way .....	543	Pavement Crown .....	302
Occupational Safety and Health .....	41	Pavement Depression .....	296
Occupational Safety and Health Act.....	488	Pavement Edge .....	177
Offset Stakes.....	536	Pavement Station Stamping .....	296
Old Substructures.....	332	Paver.....	290
On Standby.....	87	Pavers .....	292
One Call Notification.....	37	Paving Equipment.....	273
On-Job-Training Report.....	47	Paving Form Stakes.....	558
Open Abrasive Blasting .....	515	Paving Hubs .....	176
Open Blasting .....	514	Paving Train .....	293
Optional Borrow .....	122	Payment.....	102
Ordinary Surface Finish.....	395	Payments .....	106
Original Cross Section List.....	554	Payrolls .....	47, 49, 51, 52
ORM Form.....	209	PCC Daily Report of Pavement Laid (DR Form 85)	
Ornamental Handrail .....	414	.....	278
Orphan Tanks .....	505	PCC Pavement.....	269
OSHA .....	41, 485, 487, 488	PCC Pavement Equipment.....	273
Other Reference.....	457	PCC Pavement Patching.....	311
Other References.....	438, 439, 442, 449, 451, 452, 455, 456, 458	Peat Moss .....	461
Other State Highways.....	216	Peat Moss Checklist.....	461
Outlets .....	472	Ped Head .....	206
Out-of-Tolerance Tie-Bar Steel .....	289	Ped Pushbuttons .....	205
Outside Agencies Relationships.....	15	Pedestrian Heads .....	205
Overbreakage .....	154	Penetration of .....	319
Over-Excavate .....	503	Performance Graded Binder Content.....	233, 255
Over-Excavation.....	502	Permanent Benchmark.....	550
Overhaul .....	112, 174, 560	Permanent Benchmarks .....	551
Overhead and Profit .....	76	Permanent Corner Markers .....	546
Overrun Script.....	85	Permanent Seeding Dates.....	444
Overruns and Underruns Letter.....	136	Permanent Station Numbers .....	296
Oversight Projects .....	15	Perpetuation of Section Corner Markers .....	546
Oversize Hauling.....	168	Photographs .....	104
Overtime .....	51	Pier .....	375
Overweight Axle Loads.....	168	Pile Driving .....	333
<b>P</b>		Pile Driving Analyzer .....	318, 320, 321
P.C. ....	535	Pile Driving Constraints .....	334
P.E.P. ....	259	Pile Driving Procedures.....	316
P.E.P. Guidelines .....	259	Piles and Pile Driving .....	117
		Piles and Pile Driving Checklist .....	315
		Pilot Car .....	212
		Pilot Cars.....	212

Pipe .....	420	Preformed Neoprene Joints.....	400
Pipe Arch Culverts.....	119	Preformed Polychloroprene Elastomeric Type.....	301
Pipe Arches.....	117, 422	Preliminary Cross Section Listings.....	554
Pipe Culverts.....	117, 539	Preliminary Cross Sections.....	553
Pipe Ordered But Not Used .....	119	Preliminary Survey.....	560
Pit Materials .....	121	Preliminary Surveys .....	551, 552
Pit Site .....	186	Preparation of Existing Box Culverts.....	115
Place Sod .....	450	Preparation of Existing Structures.....	114
Placement Procedures .....	263	Preparation of Subgrade .....	279
Placement Rates.....	245	Prepour Meeting .....	378
Placement Tolerances .....	288	Presence on Site.....	12
Placing.....	290	Presodding .....	450
Placing Concrete .....	389, 411	Prestressed Concrete Bearing Pile .....	321
Placing Concrete and Form Removal.....	411	Pre-Watering .....	148
Placing Reinforcing Steel.....	288	Prewatering Plan .....	171
Plan Data .....	556	Price Adjustment.....	124
Plan Revisions .....	80	Prime Coat .....	178, 185
Plan Stationing .....	181	Prime Coat and Tack Coat .....	113
Planimeter		Procedures & Comments .....	457, 458
Projects .....	555	Procedures and General Comments.....	456
Planimeter Method .....	110	Processing As Built Plans.....	135
Plans and Working Drawings .....	12	Profilograph .....	98, 309
Plant Calibration .....	379	Profilograph Tests.....	98
Plant Inspection.....	92	Progress.....	103, 142
Plant Inspector .....	93	Progress Estimates .....	106
Plant Monitor.....	92, 236	Progress of Work .....	73
Plant Procedures.....	265	Progress Schedule.....	67
Plant Reports .....	93	Project Acceptance .....	124
Plant Ticket.....	271	Project Details .....	32
Plants .....	27	Project Development Summary Sheet.....	491
Plastic Barrels .....	181	Project Finalization.....	124
Plastic Concrete .....	305	Project Manager .....	16, 19
Plastic Drums.....	213	Project Manager (PM).....	6
Platform Scale.....	97	Project Manager's Involvement.....	46
Plotted Cross Sections .....	555	Project Station Reference Stakes .....	188
PMS Activity 340.....	493	Project Supervision .....	28
Pole Bases.....	204	Project Suspensions .....	74
Pole Foundations .....	203	Projects Limit.....	171
Pole Mounted Cabinets .....	205	Property Damage.....	208
Poles .....	204	Protection .....	297
<i>Poles and Towers</i> .....	199	Protection of Foundation Course .....	279
Polyethylene Sheeting .....	298	Protection of Pavement.....	280
Pond .....	170	Public Relations .....	13
Pond Borrows.....	511	Public Relationships.....	13
Poor Fusion.....	360	Pugmill .....	182, 236
Porous Backfill .....	473	Pull Boxes .....	194
Portland Cement Concrete (PCC) Pavement.....	263	Pulverized Soil Binder .....	182
Portland Cement Concrete Pavement .....	269	Pump Placement.....	394
Portland Cement Concrete Paving Plant .....	92	Pushbutton Signs.....	205
Portland Cement Treated Foundation Course.....	185	Pushbuttons.....	205
Post Sodding.....	450		
Postings.....	27, 63	Q	
Pot Bearings .....	367	QA/QC .....	232
Power Tool Cleaning .....	515	QA/QC Program .....	232
Practical Refusal .....	320	QA/QC Projects .....	236
Preconcreting Conference .....	278	QA/QC Specification .....	93
Preconstruction Chaining.....	537	QC Lab Technician .....	236
Preconstruction Conference.....	25, 146, 197	QC Program .....	234
Pre-Construction Confernece.....	202	Quality Assurance Section .....	309
Preconstruction Cross Section Notes .....	567	Quality Assurance/Quality Control .....	234
Preconstruction Cross Sections .....	552, 560	Quality Control Methods.....	248
Preformed Loops.....	202	Quality Control Monitoring .....	247

R

@

R.O.W. Limit Listings .....	555
R2-1 Speed Limit Sign .....	220
R2-1wz Fines Double Plate .....	219
Radius Computation .....	111
Rail Alignment .....	469
Rail Height .....	469
Rail Section Location .....	469
Railroad Protective Insurance .....	33
Railroad Right-of-Way .....	37
Railroad Safety Training .....	39
Rain Damage .....	304, 305
Raised Pavement Markers .....	213
Random Cracks .....	311
Random Sampling .....	243
Range Poles .....	579
Rate of Fertilizer .....	436
RCRA .....	487, 488
RDP Form 344, Evaluation of Contractor .....	137
RDP Form 344; Evaluation of Contractor (EOC) ...	138
RDS Design Data .....	557
RDS Earthwork Quantities List for Roadways .....	555
Reading the Rod .....	537
Ready Mix Concrete .....	271
Ready Mix Tickets .....	92
Ready Mixed Structural Concrete .....	378
Ready-Mixed Concrete .....	286
Rebalancing .....	560
Reconciliation of Records .....	78
Record of Contractor Payrolls Received .....	52
Records .....	32
Recruitment .....	31
Recyclable Abrasive .....	514
Reduced Speed Ahead .....	219
Reference Points .....	319
Referencing Centerline .....	535
Reimbursable Trainee Training Record .....	47
Reinforced Concrete Pavement .....	299
Reinforcement .....	118, 368, 409
Reinforcement Bar Cover .....	410
Relations .....	14
Remediated Soil .....	503
Removal and Disposal of Old Pavement .....	162
Removal of Existing Structures .....	114
Removal of Falsework .....	345
Removal of Forms and Falsework .....	387
Removal of Soil Disposing in a Sanitary Landfill .....	502
Removal of USTs .....	500
Removal of Wall Forms .....	411
Removed Bituminous Materials .....	162
Removed Concrete .....	162
Removing and Resetting Trees .....	438
Removing and Resetting Trees Checklist .....	438
Removing Materials from Projects .....	11
Rental Rate Blue Book .....	75, 87
Rented .....	76
Repair of Damaged Coating .....	373
Repair of Deficient Pavement .....	305
Report of Labor Compliance Interviews .....	50

Report of Shipment of Reinforced Concrete .....	420
Reportable Quantities .....	522
Reporting Violations .....	187
Reports .....	40, 46
Request for Authorization of Additional Classification and Rate .....	50
Required Posting .....	43
Requisition and Transfer .....	572
Residue Rates .....	242
Resource Conservation and Recovery Act .....	488
Resurfaced PCC .....	311
Retarders .....	406
Retarders - Retarders .....	392
Retarding Admixtures .....	384
Rice Voidless Density .....	242
Riding Qualities .....	293
Right-of-Way .....	29, 127
Right-of-Way Fence .....	570
Right-of-Way Fence Stakes .....	570
Right-of-Way Limit Listing .....	570
Right-of-Way Lines .....	547
Rights of Adjacent Property Owners .....	146
Rigid Pavements .....	177
Rivers and Harbors Act .....	496
Road Construction Ahead .....	210
Road Design System (RDS) .....	561
Road Gravel Requirements English Version .....	190
Road Work Ahead .....	210
Roadside Development & Erosion Control .....	435
Rock .....	189
Rock Material .....	164
Rock or Aggregate Surfacing .....	186
Rods .....	579
Roller Marks .....	254
Rome Disc .....	436
Rotational-Capacity .....	351
Rough Pavement Sections .....	306
Rough Sawn Timbers .....	339
Rough Welding .....	359
Rounding of Hinge Points .....	158
Royalty Payments .....	122
Rubbed Finish .....	395
Rubber Grommets .....	204
Rules-of-Thumb .....	517
Rumble Strip .....	246
Rumble Strips .....	246
Rural Areas .....	216
Ruts .....	402

S

S.C. ....	535
S.T. ....	535
Safe Drinking Water Act .....	489
Safe Work Site .....	63
Safety .....	29, 36, 63, 203
Safety Areas .....	157, 231, 264, 266, 268
Safety Inspections .....	63
Salvage .....	425
Salvage of Equipment .....	579
Salvage Value .....	222, 425
Salvaged Asphaltic Cement Concrete Pavement ..	162

Sample Identification Form .....	235	Shoulder.....	252, 402
Samples.....	92, 243	Measured .....	181
Sampling.....	186, 501	Shoulder Construction.....	567
Sampling Requirement/Freq.....	231	Shoulder Lines.....	152
Sand.....	189	Shoulder Maintenance .....	402
Sand Gravel.....	189	Shoulder Subgrade Preparation.....	177
Sand Pockets.....	173	Shoulders .....	559
Sandblast.....	302	Shrinkage .....	163
Sand-Gravel.....	189	Shrinkage Cracks.....	306
SARA.....	489	Sieves .....	577
Saturdays.....	68	Sign Color.....	208
Saw Cuts .....	311	Sign Maintenance .....	222
Sawed Joint .....	301	Sign Mounting Devices.....	214
Sawing Equipment .....	276	Sign Shape.....	208
Saws.....	276	Sign Size .....	208
Scale Bins.....	282	Sign Word Message.....	207
Scale Calibration Record .....	283	Signal Ahead Signs.....	206
Scale Houses.....	465	Signal Head.....	206
Scale Tickets.....	96, 105	Signal Heads .....	205
Scale Weights .....	282	Signing .....	218, 219
Scales.....	96, 97, 273, 281	Signing Changes.....	207
Scarifying .....	239	Signing Service.....	22
Schedule of Delivery.....	286	Signs .....	62, 181, 193, 222
Scotchkote 213 .....	375	Signs Not Returned.....	222
Scotchkote 312 .....	375	Silicone Sealants .....	302
Screed .....	293	Silt Clay Soils.....	180
Screeds.....	275	Silt Fencing.....	454
SDWA.....	489	Silt Fencing Checklist.....	455
Sealing Equipment .....	303	Silt Fencing Procedures .....	455
Sealing Joints.....	300	Silt-Clay.....	180
Section.....	181	Site Inspections .....	42
Section Corner .....	547	Site Mixers.....	286
Section Corners .....	310	Site Safety .....	502
Seed.....	444, 453	SiteManager .....	527
Seed Bed.....	444, 452	Skew Angles.....	331
Seed Mixtures .....	436	Skewed Dowels .....	299
Seeding .....	442	Skidmore-Wilhelm Calibrator .....	353
Seeding and Slope Protection.....	121	Skidmore-Wilhem Calibrator.....	324
Seeding Checklist.....	442	Slab.....	375
Seeding Procedures .....	442	Slab Report .....	290
Segregated Facilities .....	29	Slab Thickness .....	291, 368
Self-Propelled Concrete Spreader.....	293	Slider .....	446
Self-Propelled Finishing Machine .....	293	Slides .....	154
Self-Propelled Finishing Machines .....	392, 406	Slip Form Barrier Rail.....	403
Services Relationships .....	13	Slip Form Paving Equipment .....	276
Set Accelerating Admixtures .....	382	Slip-Form.....	291
Set Retarding Admixtures .....	382	Slip-Form Construction.....	291
Settlement.....	150, 177	Slip-Forming .....	290
Settlement of the Falsework.....	344	Slope Protection .....	456
Severe Personal Injury .....	209	Slope Protection Checklist.....	456
Sewers.....	120	Slope Protection Netting.....	457
Shadowing .....	410	Slope Protection Netting Checklist.....	457
Shale Cuts .....	164	Slope Stake Book .....	555
Shallow Penetration.....	360	Slope Stakes .....	555, 556
Sheet Piles.....	317	Slopes .....	152
Sheet Piling.....	117	Slow/Slow Paddle .....	212
Shells.....	315	Slow/Slow Paddles.....	212
Shipping.....	578	Smoothness.....	98, 252, 254, 413
Shop Coat.....	416	Smoothness Tests .....	309
Shop Drawings and Materials List .....	198	Snow Removal.....	211
Shore Head.....	342	Snug Tight.....	352
Shoring Components.....	342	Sod .....	450



Sod Bed.....	450	Standard Labor Classifications .....	50
Sod Placement.....	450	Standby Time .....	77
Sodding .....	449	Stand-by Time .....	287
Sodding Checklist.....	449	State Maintenance Patching.....	258
Sodding Procedures.....	449	State Option.....	121
Soft Ground.....	169	State Property Damage Report.....	208
Soft Shale .....	164	State Supplied Material .....	203
Soft Subgrades .....	239	Statement of Compliance .....	49, 50, 51, 108
Soil Aggregate Base .....	183	Statement of Materials and Labor .....	109
Soil Aggregate Base Course		Form FHWA-47 .....	131
Tolerance.....	183	Static Pile Load Test Procedures.....	320
Soil Binder .....	180, 189	Station Numbers .....	297
Soil Burning.....	503	Stationary Mixers .....	286
Soil Erosion.....	459	Steel "H" .....	319
Soil Load Test.....	338	Steel Girder Bridges.....	558
Soil Moisture .....	148	Steel Overhang Brackets.....	340
Soil Samples.....	153	Steel Pile Cutoffs .....	334
Soil Setup Factor.....	318	Steel Piling .....	315
Soil Type.....	166, 177	Steel Reinforcing Bars.....	288
Soil Types .....	163	Steel Roller .....	241
Solid Waste.....	497	Steel Structures .....	336
Spade Lugs.....	204	Stock Returned for Credit.....	123
Spalls.....	301	Stockpile.....	281
Span Wire .....	204	Stockpile Item .....	107
Special Equipment .....	237	Stockpiled.....	210
Special Treatments.....	240	Stockpiled Material.....	27, 107
Specialty Items.....	71	Stockpiles .....	59
Speed Limit.....	216	Stockpiling .....	107, 147
Speed Limit Signs .....	218, 219	Stop Bars .....	215
Speed Limits .....	216	Stop Sign Removal .....	206
Speed Limits in Construction Work Areas.....	217	Stop Signs.....	209
Speed Zone .....	216	Stop/Slow Paddle.....	212
Speed Zone Authorization .....	218, 224	Storage Areas.....	210
Speed Zone Authorization Form.....	218	Storage Locations.....	211
Spike Tooth Harrow.....	436	Storm Water Compliance .....	511
SPILL CONTROL.....	507	Straightedge .....	254
Splice Kit.....	204	Straightedging .....	294, 408
Splices .....	204	Stranded Wire.....	204
Splicing .....	376	String.....	240
Splicing Pile .....	334	String Support Arms.....	240
Split-Ball .....	447	Struck Loads.....	188
Spray Bar.....	242	Structural Concrete .....	380
Spread Footings.....	338	Structural Concrete Plant .....	92
Spreader .....	275, 293	Structural Joints.....	346
Spreading .....	290	Structural Steel .....	339
Spreading Layers .....	245	Subcontract .....	22
Spring Tooth Harrow .....	436	Subcontracted Items .....	79
Spud Wrench .....	352	Subcontracting.....	28
SRT .....	470	Subcontracts.....	18
SS-1 .....	241	Subdrain Earthwork.....	472
SS-1H.....	241	Subdrains.....	472
SSHC Reference.....	442, 449, 451, 452, 455, 456	Subgrade.....	176, 239, 290
SSHC References.....	227, 263, 265, 267, 438, 439, 457, 458	Damage .....	178
SSHC Subsection 703.03 .....	316	Subgrade Cross Sections.....	279
Stability and Settlement Indications.....	156	Subgrade General.....	279
Stabilization.....	510	Subgrade Preparation .....	176, 177
Staff Requirements.....	17	Subgrade Stabilization .....	180
Stakes.....	580	Subgrade Trimmer .....	275
Stakes Used.....	331	Subgrade Trimming.....	178
Staking.....	187, 331, 531	Subsurface Concerns.....	150
Staking Culverts .....	542	Summary Form of Tests of Asphalt Mixtures.....	235
		Sundays .....	68

Superfund Amendments and Reauthorization Act.....	489	Testing of Lighting Systems.....	198
Supplies.....	579	Testing Procedures.....	271
Support Rails.....	408	Testing Sieves.....	577
Supports.....	370	Thank You Drive Safety Sign.....	220
Surface Cleaning.....	280	Thickness.....	183
Surface Correction.....	413	Thickness Cores.....	183, 309
Surface Courses.....	245	Thickness Measurements.....	279
Surface Finish.....	395	Thickness Requirements.....	309
Surface Finishing.....	293	Threads.....	353
Surface Holes.....	359	Threshed Grain Straw.....	448
Surface Irregularities.....	254	Thrie-Beam Guardrail.....	469
Surface Water.....	522	Ticket.....	271
Surfacing.....	135	Tickets.....	96, 114
Surfacing Data.....	563	Tie Steel.....	288
Surfacing Gravel.....	189	Tie-Bar Steel.....	288
Survey Errors.....	331	Tie-Bar Steel Inspection.....	288
Survey Levels.....	575	Tie-Downs.....	370
Survey Monument.....	546	Tile Relocations.....	472
Survey Party.....	535	Timber.....	316, 319, 339
Suspension of Work.....	71	Timber Construction.....	340
		Timber Piling.....	345
<b>T</b>		Time	
T.S.....	535	Active.....	77
Tack Coats.....	241	Standby.....	77
Tacked Stakes.....	535	Time Suspensions.....	71
Tamp.....	450	Tine Determination.....	296
Tank Measurement.....	255	Tining.....	295, 408
Tank Removal.....	500	TITLE III.....	489
Tanks.....	499	TITLE III of SARA.....	489
Taper Lengths.....	207	Toe Berms.....	170
Taper Location.....	208	Toe Stakes.....	170
TCLP.....	517	Tolerance.....	536
Temperature of Concrete.....	388	Top Layer.....	253
Template.....	178	Top Steel.....	392, 406
Temporary Barrier.....	213	Topographic Maps.....	165
Temporary Cover.....	512	Topographical Map.....	165
Temporary Erosion Control.....	460	Topsoil.....	173
Temporary Fastenings.....	336	Torque Wrench Calibration.....	353
Temporary Filler.....	299	Total Hourly Rate.....	75
Temporary Lighting System.....	200	Total Station.....	576
Temporary Lighting Units.....	200	Total Stations.....	573
Temporary Pavement Marking Type I or Type II.....	215	Touch-Up Material.....	375
Temporary Pavement Marking, Type I.....	215	Tower Foundations.....	198, 370
Temporary pavement Marking, Type II.....	215	Towers.....	204
Temporary Pavement Marking, Type RPM.....	215	Toxic Characteristic Leaching	
Temporary Pavement Markings.....	215	Procedure Testing.....	517
Temporary Signal.....	202	Toxic Substance Control Act.....	489
Temporary Stop Sign.....	210	Traffic Control.....	193
Temporary Surfacing.....	188	Traffic Control Removal.....	213
Temporary Traffic Signals.....	212	Traffic Control Signing.....	207
Temporary Water Pollution Control		Traffic Control Signing Changes.....	207
(Soil Erosion).....	459	Traffic Engineering.....	202
Temporary Wire Fasteners.....	303	Traffic Signal Heads.....	205
Tension Bolt.....	353	Traffic Signals.....	193, 202
Tension Measuring.....	353	Trainee Recruitment.....	46
Tentative Beginning Date.....	66	Trainee Reimbursement.....	45
Test Strips.....	244	Training.....	31, 44
Test Well Location.....	405	Training Program.....	42, 44, 46
Test Wells.....	405	Transit Mixers.....	277, 287
Testing Equipment.....	92	Transit Points.....	535
Testing of Aggregate.....	186	Transitions.....	293
		Transit-Mixed Concrete.....	287

Transverse Construction Joints	298
Transverse Contraction Joints	299
Transverse Expansion Joints	298
Transverse Finishers	293
Transverse Grooving	295, 307
Treated Timber	316
Trench Excavation	472
Trimming	182, 183
Stakes	558
Trimming Tolerance	178
Truck	187
Truck Agitator	290
Truck Capacity Computations	113
Truck Mixer	290
Truck Mixers	285, 286
Truck Platform Scale	97
Truck Weights	95
Trucks and Mixers	274
Truck's Gross Mass	187
TSCA	489
Tubular Markers	213
Tubular Steel Shoring	340
Turn-of-Nut Inspection	354
Turn-of-Nut Method	351
Two Way Traffic" (W6-3)	213
Two-Lane, Two-Way Condition	220
Type "J" Terminal	470
Type I Object Marker	221
Type II Barricades	213, 221
Type III Barricade	210
Type III Barricades	220
Typical Channel Section	116

**U**

Unauthorized Work	142
Uncompleted Projects	211
Uncontrolled Crack	300
Undercut	359
Undercutting Slopes	559
Underground Storage Tanks (USTs)	499
Underground Tanks	499
Union Pacific Railroad	37
University of Nebraska	
Conservation & Survey Division	165
Unknown Tanks	505
Unreturned Signing	222
Unstable Areas	239
Unstable Subgrades	239
Unsuitable Material	154, 164, 239
Unsuitable Material Excavation	329
Urban Areas	216
Urban Projects	212
Urban Work	178
Use of Insulated Forms for Protection	388
Used Construction Equipment	75
UST	500, 507
USTs	499
UTILDONE	38
Utilities	33, 37
Utilities Engineer	38
Utility	197
Utility Accesses	289

Utility Companies	37
Utility Properties	37
Utility Work	197

**V**

Vacuum Blasting	515
Value Engineering	90
Vehicle Accident Report	209
Vehicle Traffic on Plastic Concrete	306
Vertical Curve Grades	558
Vertical Panels	213
Vibrating Mix	405
Vibrators	275
Video Tape	181, 208
Video Tapes	104
Voids	307

**W**

W20-1	210
Wage Rate Interviews	47
Wage Rates	27, 47, 50
Wages	47
Wash Water in Transit-Mix Trucks	285
Waste Collection	514
Waste Reduction	487
Wasted Water	155
Water	171, 181, 271, 286, 294, 450
Water Meter Calibration	155
Water Pollution & Wetlands	29
Water Pollution Control (Soil Erosion)	458
Water Quality	487
Water Quality Certifications	494
Water Reducing Admixtures	382
Water Reducing Admixtures (Type A)	383
Water Supply Equipment	276
Water Valve	285
Water, Applied	155
Waterway Permits Review	493
W-Beam	469
Weeds	448
Weekdays	68
Weekly Report of Working Days	28, 74
Weld Spatter	359
Welding	356
Wells	523
Wells and Water Pollution	522
Wet Batch Trucks	277
Wet Burlap	297
Wet Soils	170
Wetland Mitigation Areas	511
Wetland Policy	496
Wetland Regulatory Authority	496
White Pigmented Curing Compound	301, 480
Wind Velocity	246
Wind Velocity Temperature	391
Wind Velocity-Temperature	405
Windrow Pick-up Elevator	238
Windrow Pick-up Equipment	238
Winter Shutdown	211
Winter Work	74
Wiring	204
Wiring Diagram	204

Witness Corners.....	547
Witnesses .....	547
<i>Wood Poles</i> .....	198
Work Area - Speed Zone Ahead.....	219
Work Area Signing .....	218
Work Area Speed Zone .....	215
Work Order .....	85
Work Orders.....	85
Work Status .....	19
Work Temporarily Suspended.....	71
Work Zone Accidents.....	209
Work Zone Signing.....	213
Working Day .....	67, 100

Working Day Report.....	69
Workload.....	17
Wrench Calibration .....	353

Y

YCCHP .....	478, 480
-------------	----------

Z

Zero-Zero Sections .....	568
Zinc Chromate .....	513
Zinc Silicate .....	513